



US00D345957S

United States Patent [19]

[11] Patent Number: **Des. 345,957**

Fleurbaey

[45] Date of Patent: **** Apr. 12, 1994**

[54] **BOAT**
[76] Inventor: **Freddy Fleurbaey**, Vuurkruisplein 12, Hoboken, Belgium

4,730,572 3/1988 Hollingsworth 114/283
4,760,810 8/1988 Kobayashi 114/56

[**] Term: **14 Years**

FOREIGN PATENT DOCUMENTS

[21] Appl. No.: **943,466**

0355211 2/1990 European Pat. Off. .

[22] Filed: **Sep. 10, 1992**

Primary Examiner—Kay H. Chin
Attorney, Agent, or Firm—Kirschstein, Ottinger, Israel & Schiffmiller

[30] Foreign Application Priority Data

Mar. 13, 1992 [XB] Benelux 22395

[52] U.S. Cl. **D12/307**

[58] Field of Search 114/270, 56, 62, 283;
D12/300, 306, 309, 316, 307

[57] CLAIM

The ornamental design for a boat, as shown.

[56] References Cited

U.S. PATENT DOCUMENTS

Re. 30,978 6/1982 Jacobson 114/270
3,077,172 2/1963 Dornak 114/62
3,216,389 11/1965 Thorsen 114/56
3,718,111 2/1973 Vecchio 114/270

DESCRIPTION

FIG. 1 is a right side elevational view of a boat showing my new design;
FIG. 2 is a left side elevational view thereof;
FIG. 3 is a front view thereof;
FIG. 4 is a rear view thereof;
FIG. 5 is a top plan view thereof;
FIG. 6 is a bottom plan view thereof; and,
FIG. 7 is a perspective view thereof.

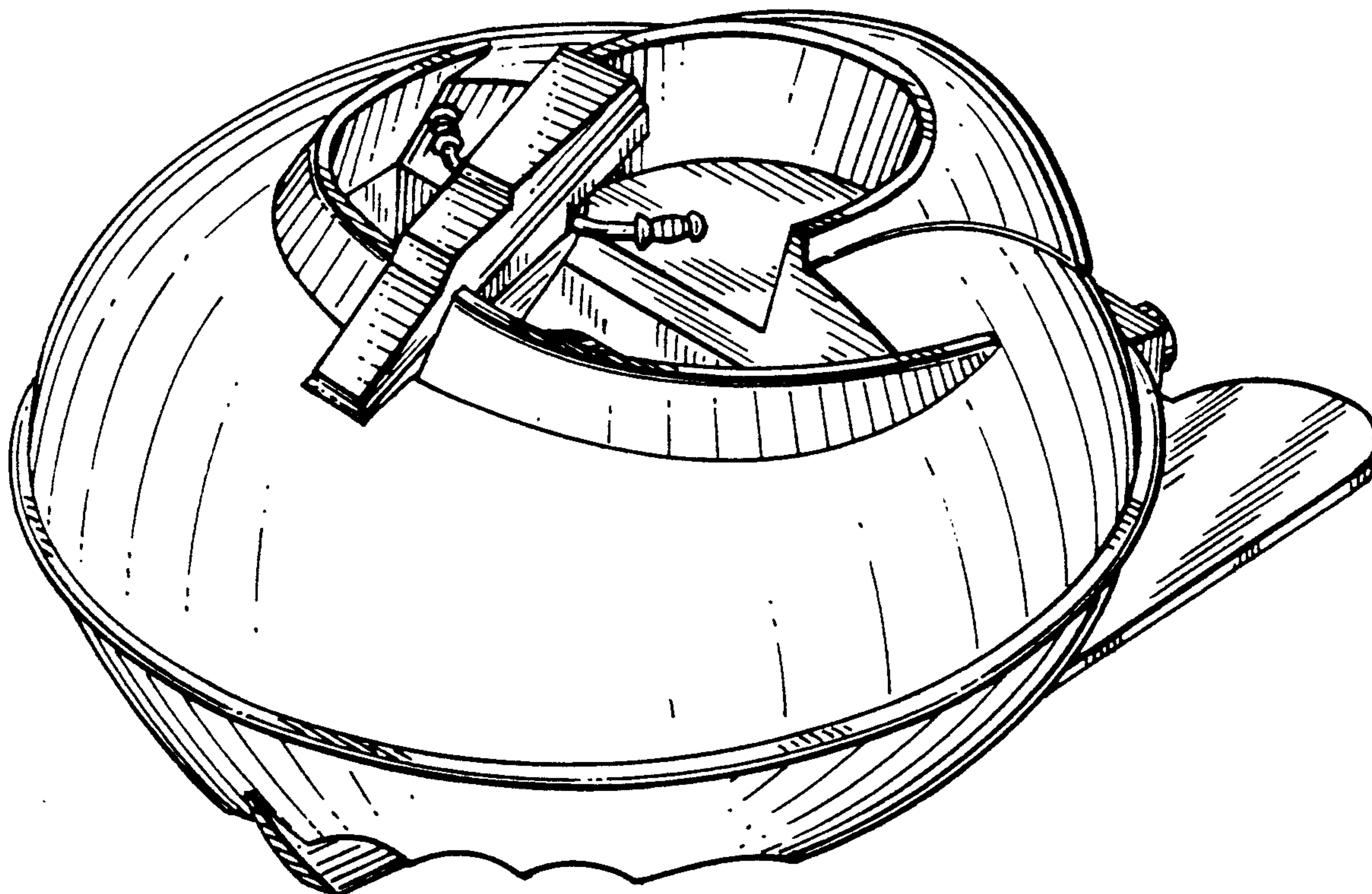

FIG. 1

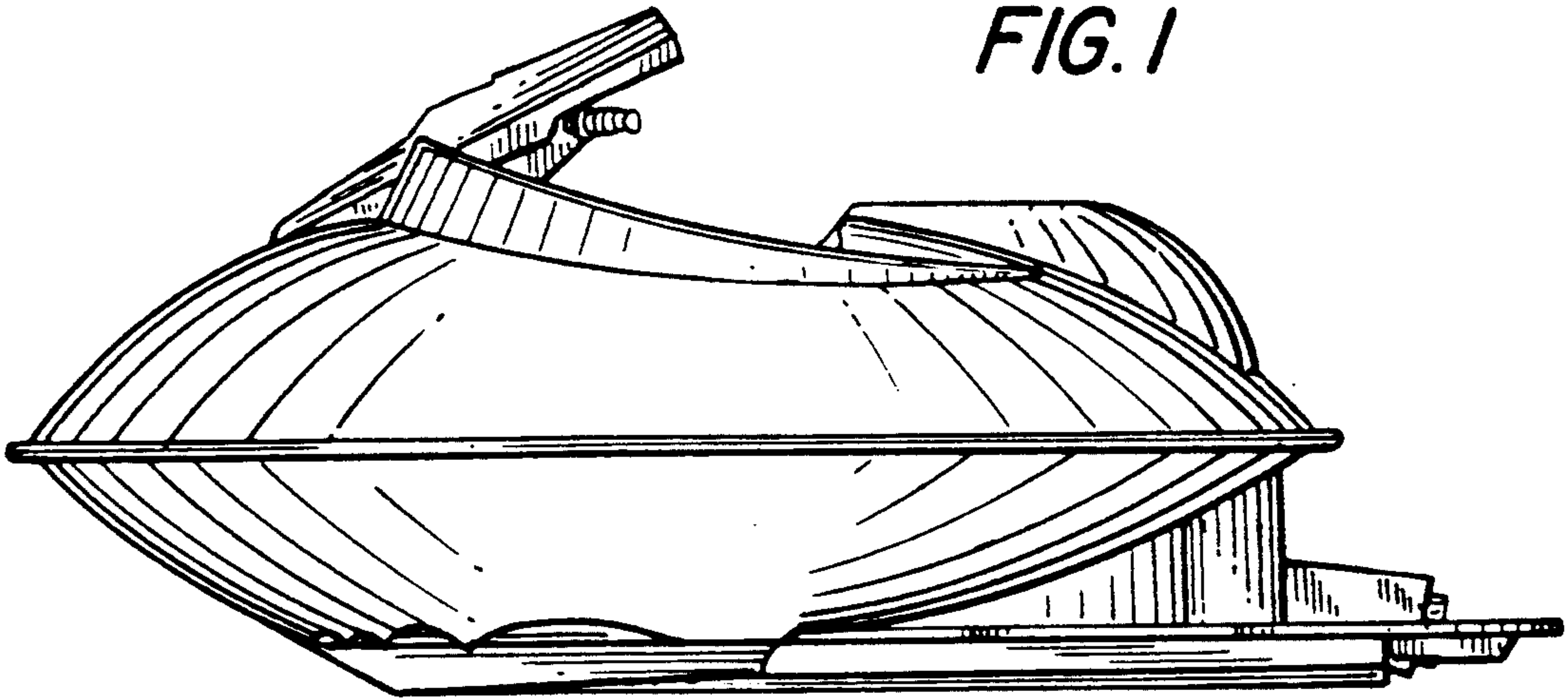

FIG. 5

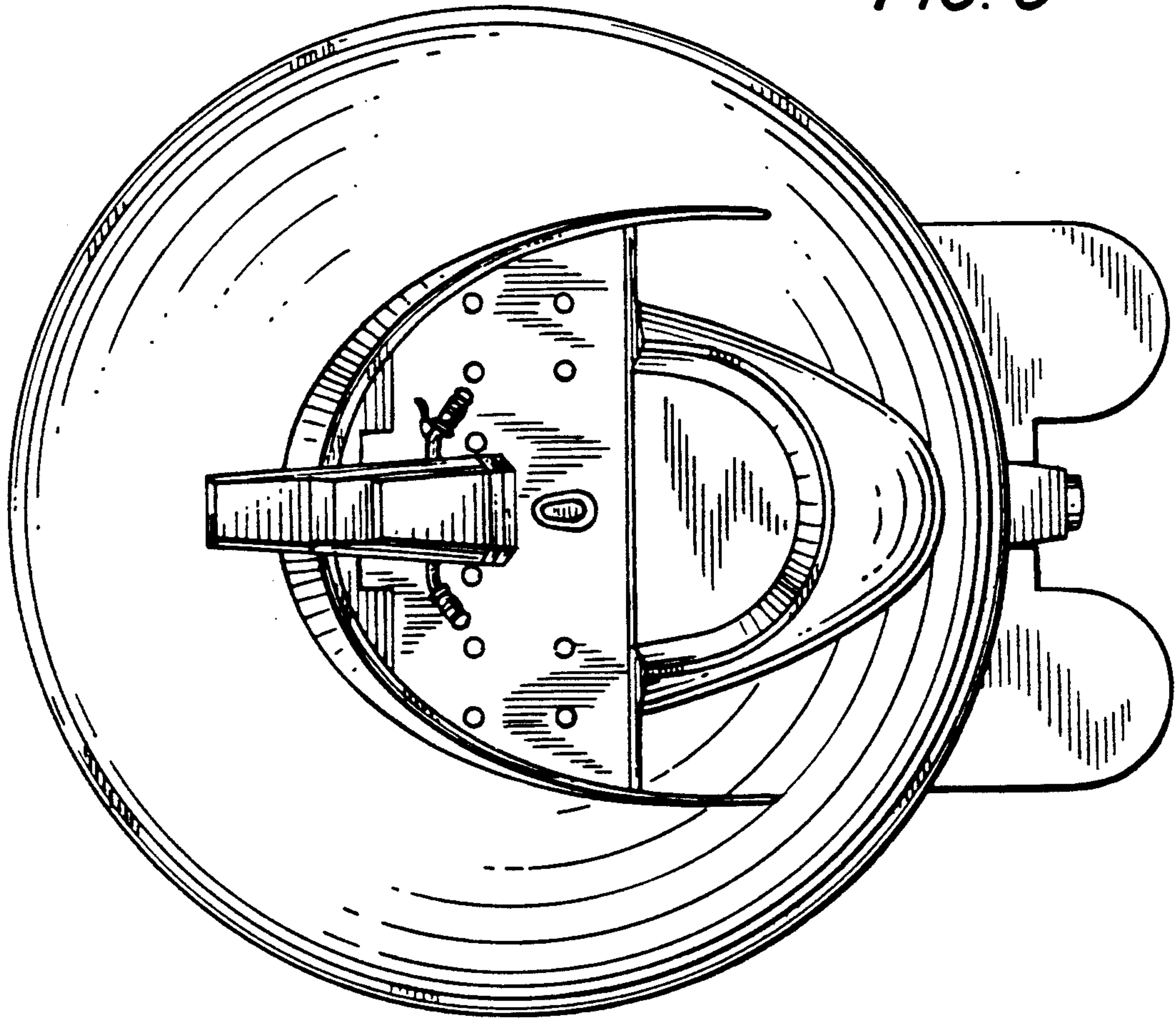

FIG. 2

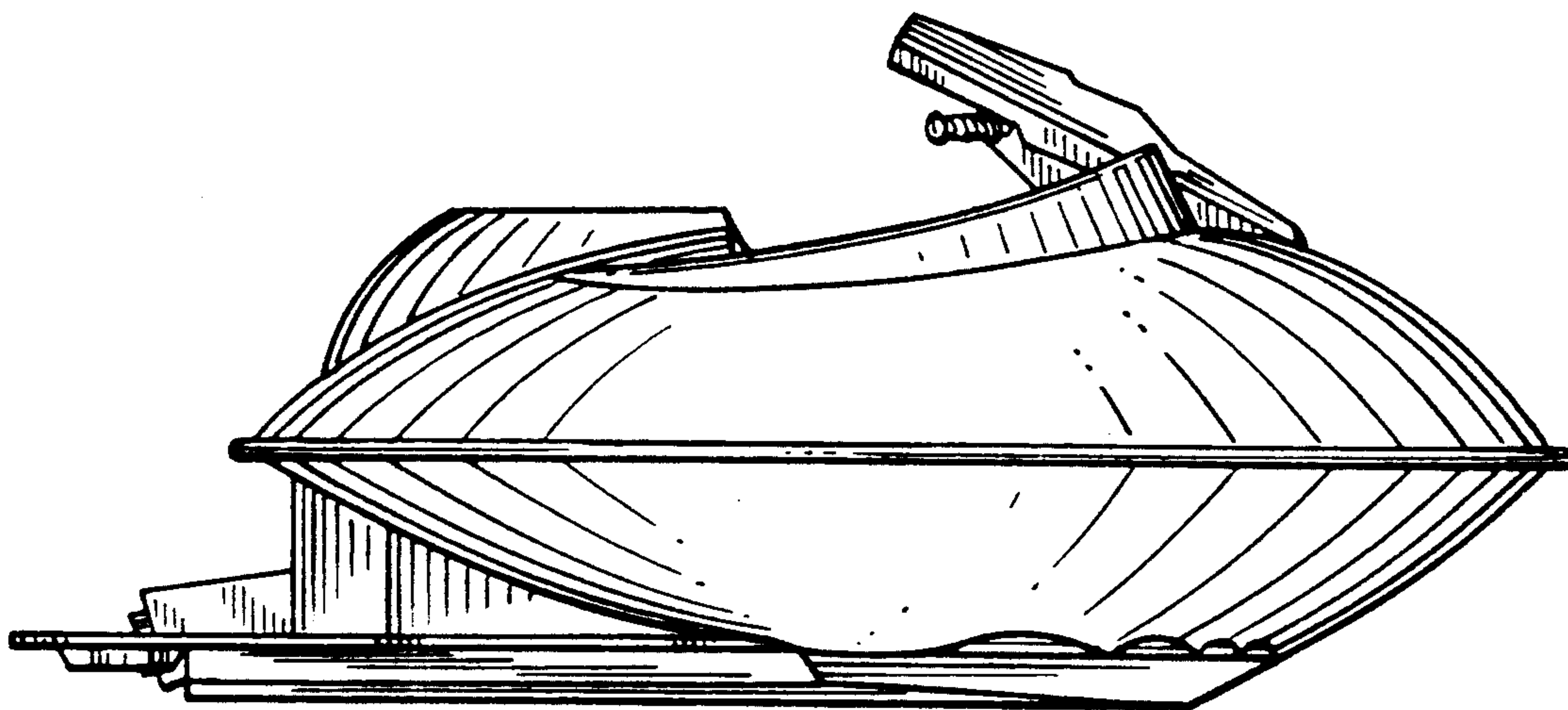

FIG. 3

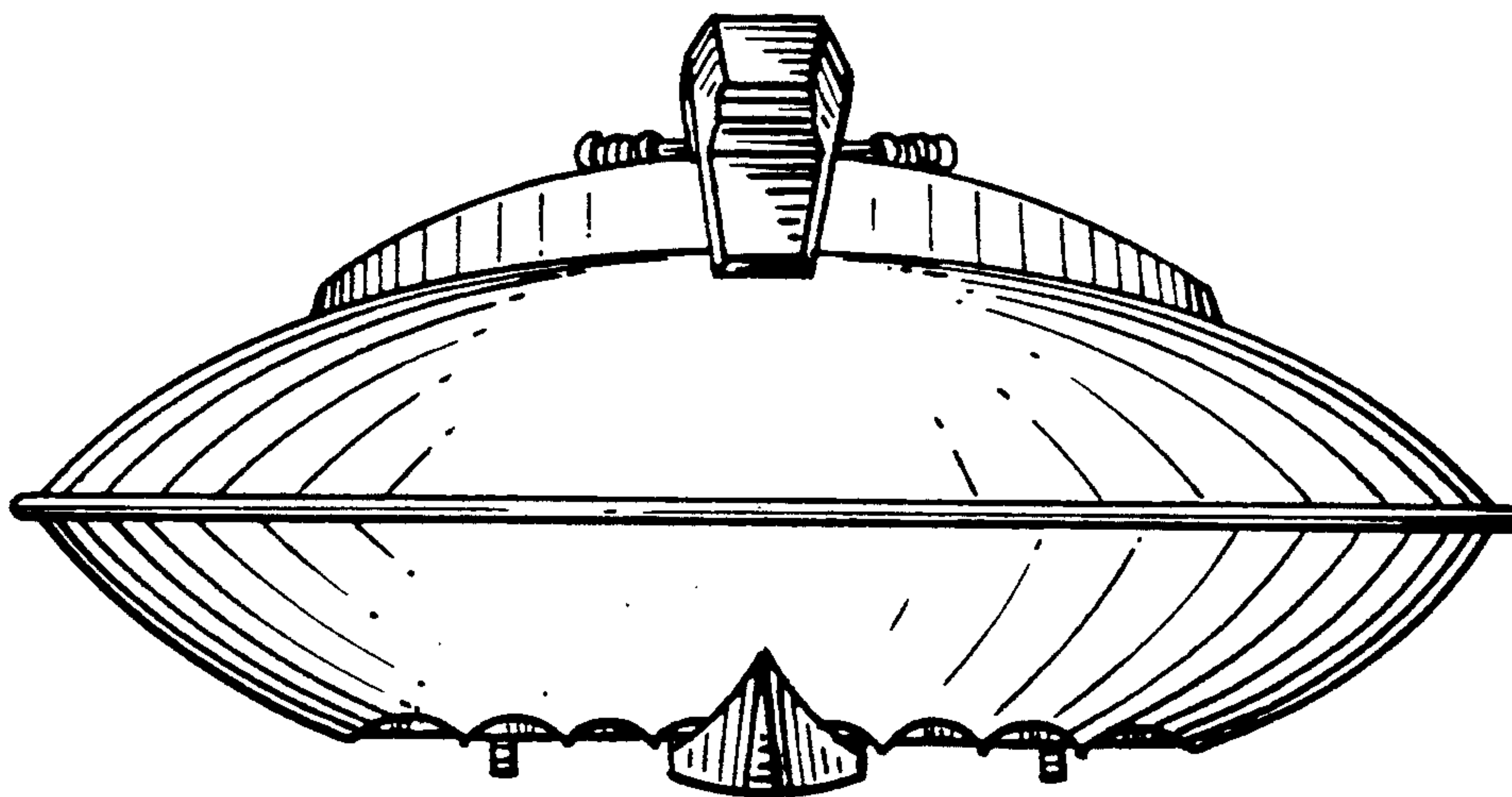

FIG. 4

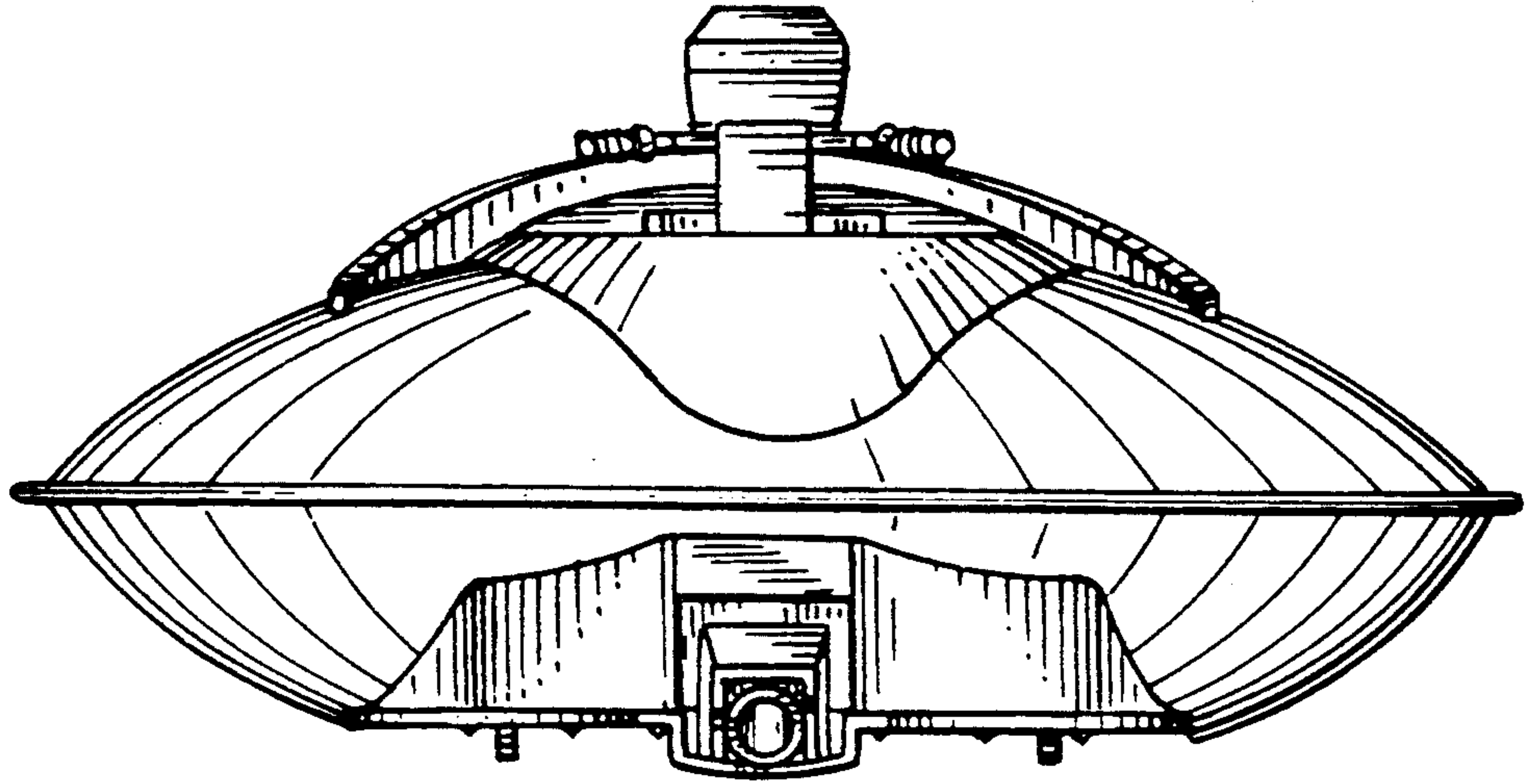

FIG. 6

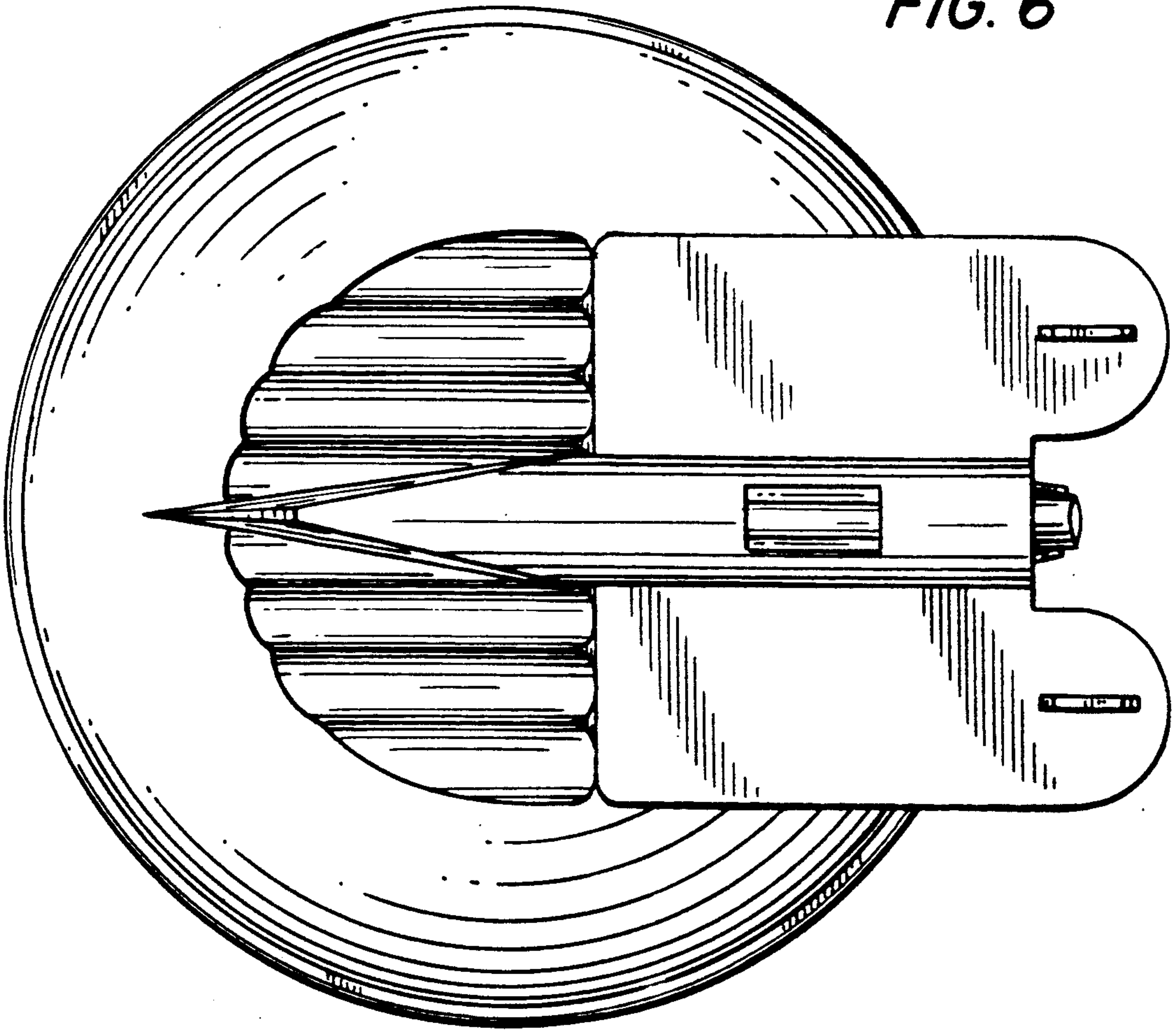

FIG. 7

