



US00D345955S

# United States Patent [19]

[11] Patent Number: **Des. 345,955**

Jeshurun et al.

[45] Date of Patent: **\*\* Apr. 12, 1994**

[54] BICYCLE HANDLEBAR

|           |         |                      |          |
|-----------|---------|----------------------|----------|
| 5,083,476 | 1/1992  | Sorromeo .....       | D12/178  |
| 5,159,851 | 11/1992 | Rahmes .....         | 74/551.9 |
| 5,165,301 | 11/1992 | Jeshurun et al. .... | 74/551.1 |
| 5,197,350 | 3/1993  | Borromeo .....       | 74/551.1 |

[75] Inventors: **David R. Jeshurun**, 952 Ridgedale, Birmingham, Mich. 48009; **Joseph Toth**, 2001 Burger, Dearborn, Mich. 48128

*Primary Examiner*—Wallace R. Burke  
*Assistant Examiner*—M. Brown  
*Attorney, Agent, or Firm*—Robert L. Marsh

[73] Assignees: **Weston Marsh; Vasanth Surath; David R. Jeshurun; Joseph Toth**

[57] **CLAIM**

[\*\*] Term: **14 Years**

The ornamental design for a bicycle handlebar, as shown and described.

[21] Appl. No.: **1,851**

**DESCRIPTION**

[22] Filed: **Nov. 24, 1992**

[52] U.S. Cl. .... **D12/178**

[58] Field of Search ..... 280/281.1, 288.1, 288.2, 280/288.3; 74/551.1, 551.8, 551.9; D12/178

FIG. 1 is a front elevational view of a bicycle handlebar showing our new design;  
FIG. 2 is a top plan view thereof;  
FIG. 3 is a rear elevational view thereof;  
FIG. 4 is a bottom plan view thereof;  
FIG. 5 is a left side elevational view thereof;  
FIG. 6 is a right side elevational view thereof; and,  
FIG. 7 is a perspective view thereof, the brake actuator handles shown in broken lines are for illustrative purposes only and form no part of the claimed design.

[56] **References Cited**

**U.S. PATENT DOCUMENTS**

|            |        |                |          |
|------------|--------|----------------|----------|
| D. 301,027 | 5/1989 | Borromeo ..... | D12/178  |
| 4,245,522  | 1/1981 | Robinson ..... | 74/551.1 |
| 4,462,267  | 7/1984 | Shimano .....  | 74/551.1 |

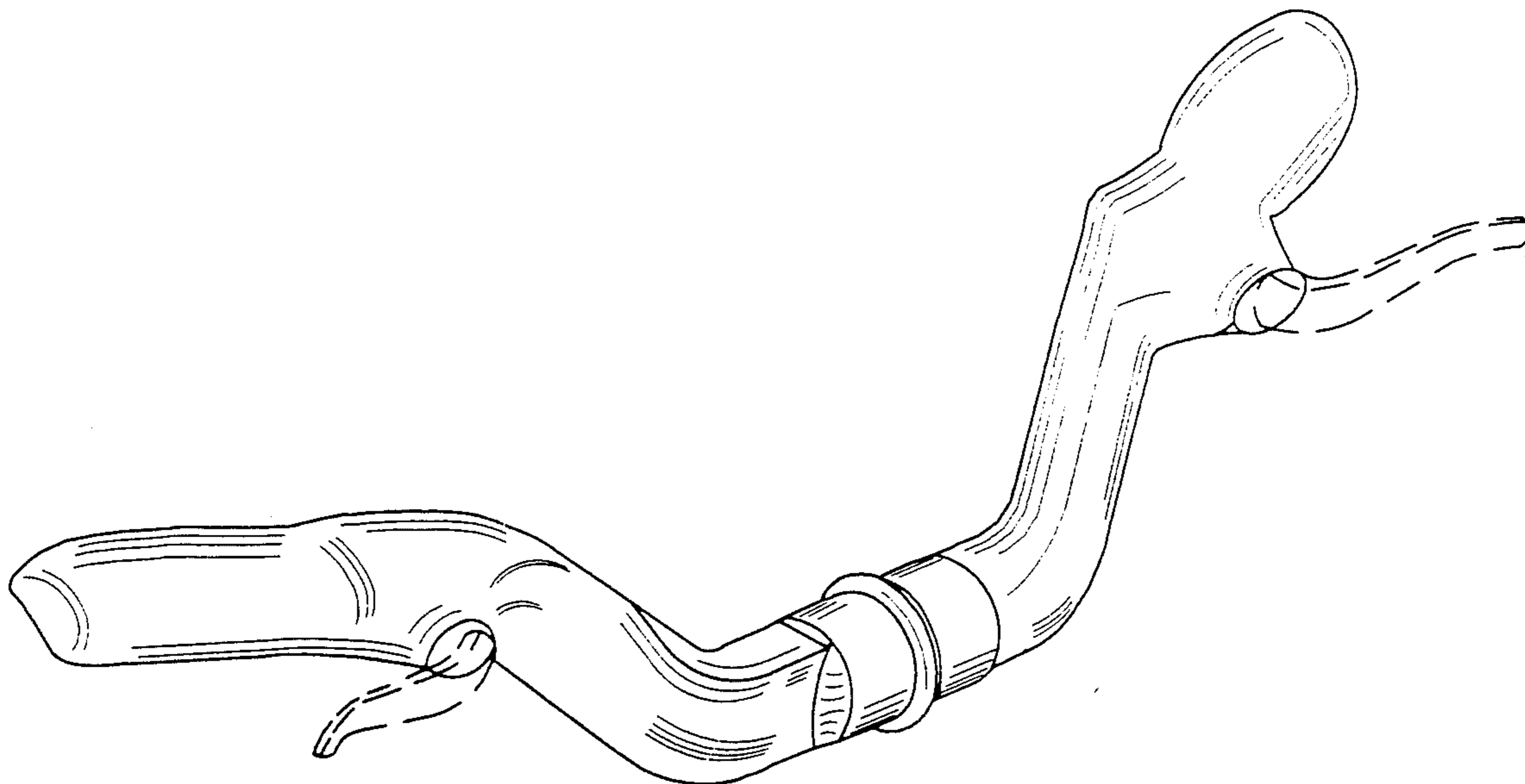

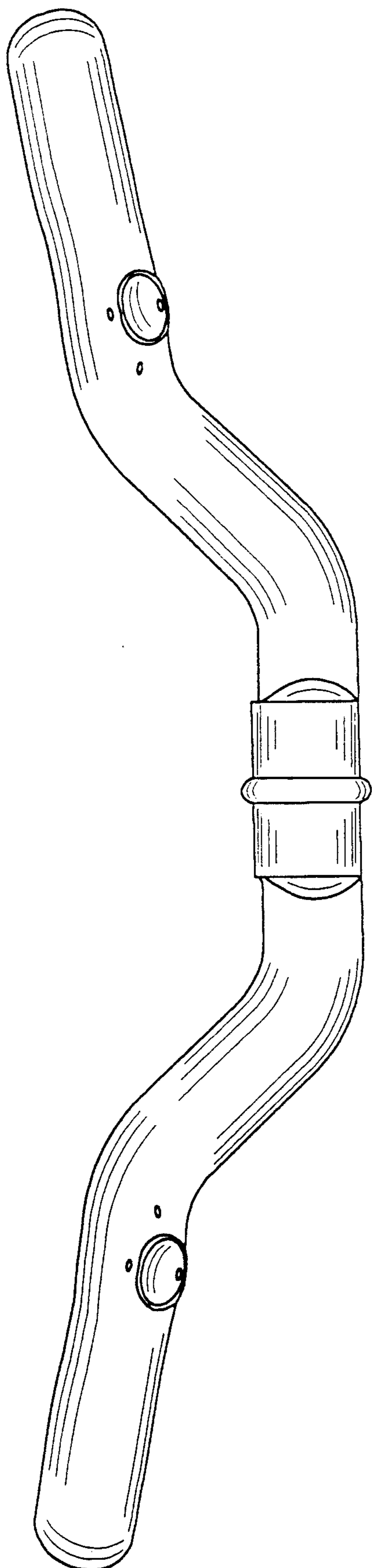

FIG. 1

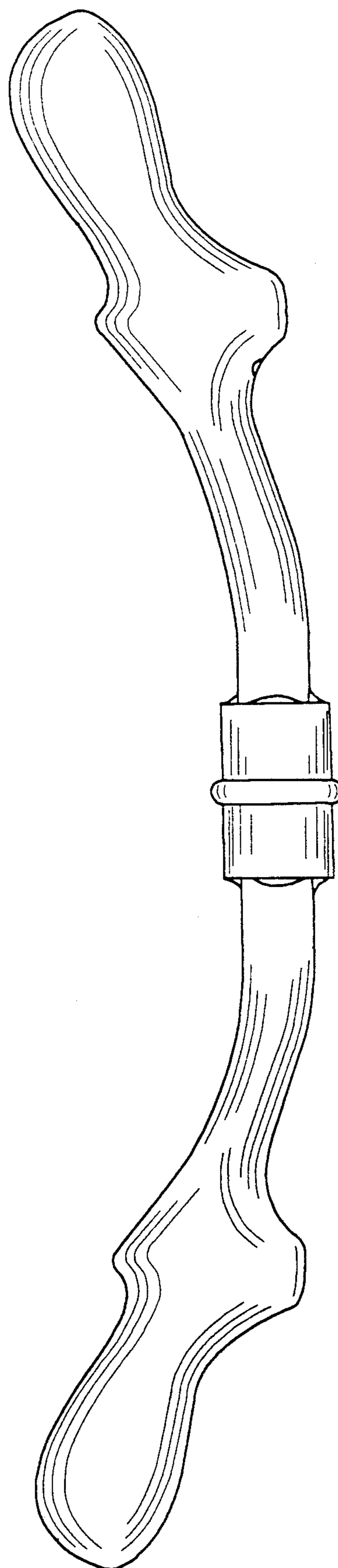

FIG. 2

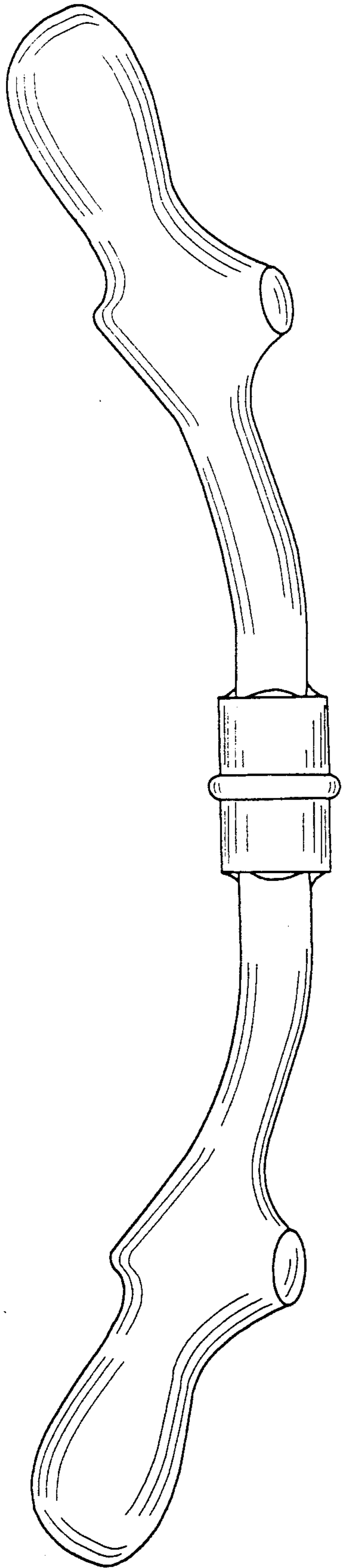

FIG. 4

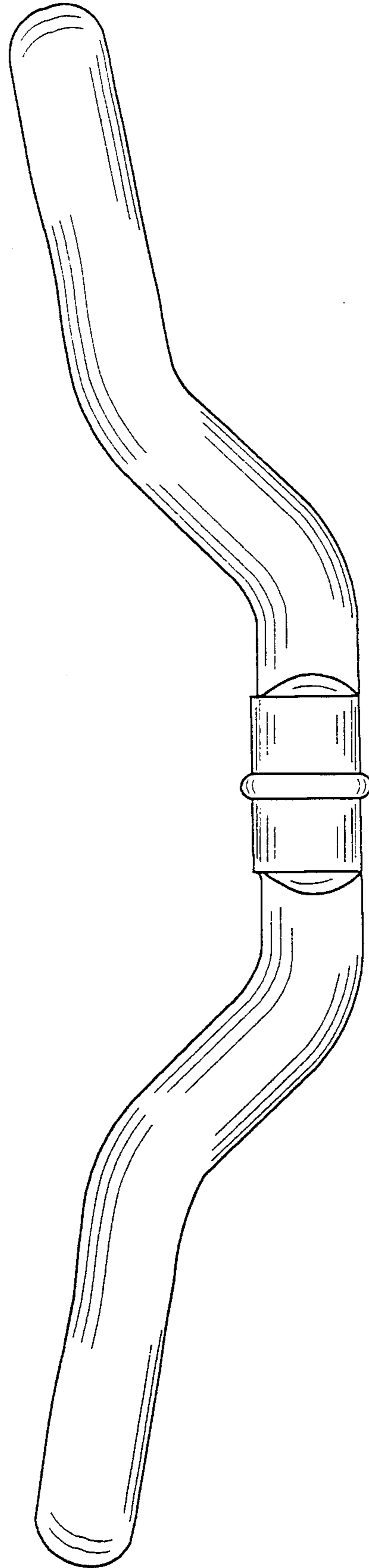

FIG. 3

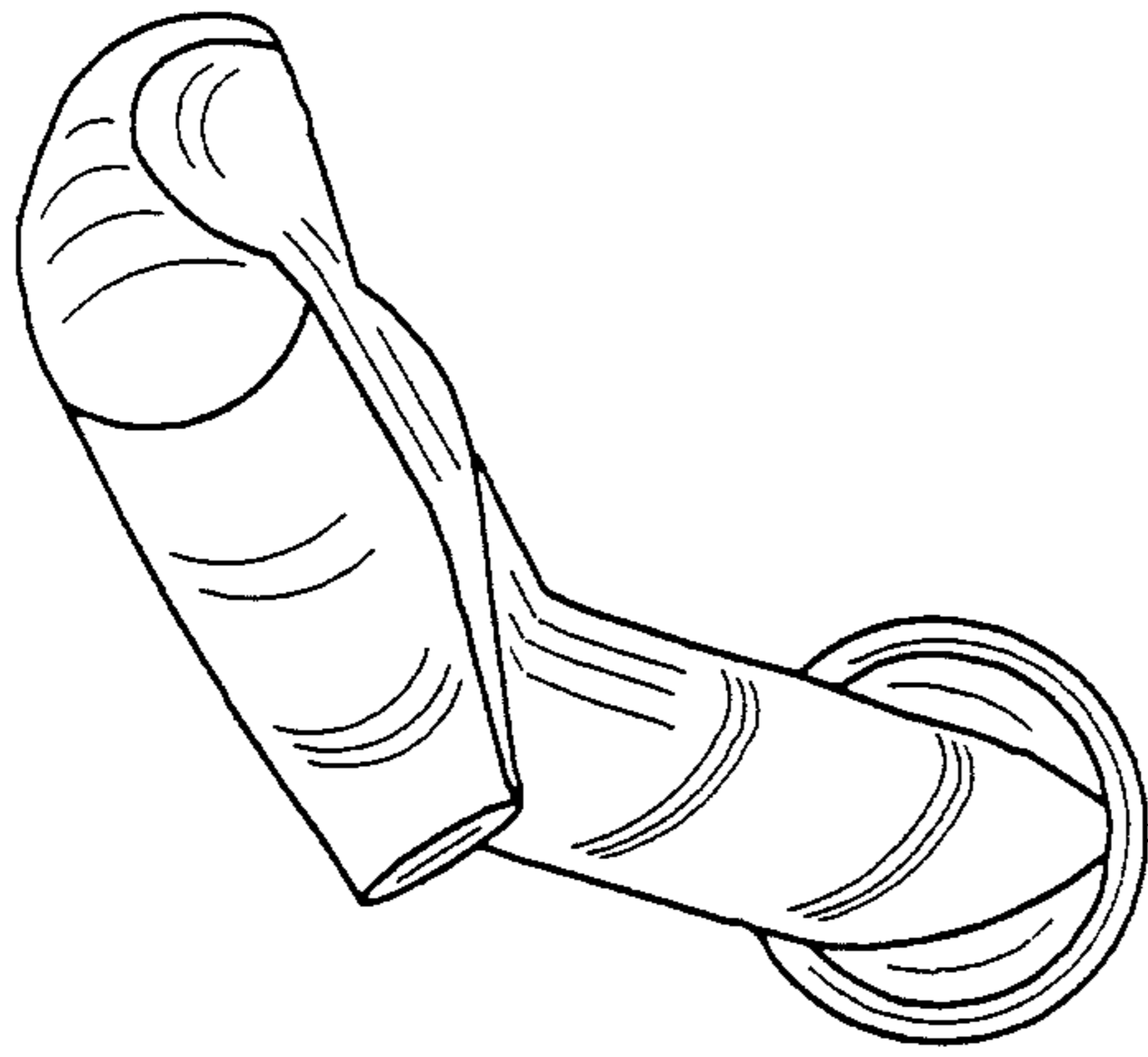

FIG. 5

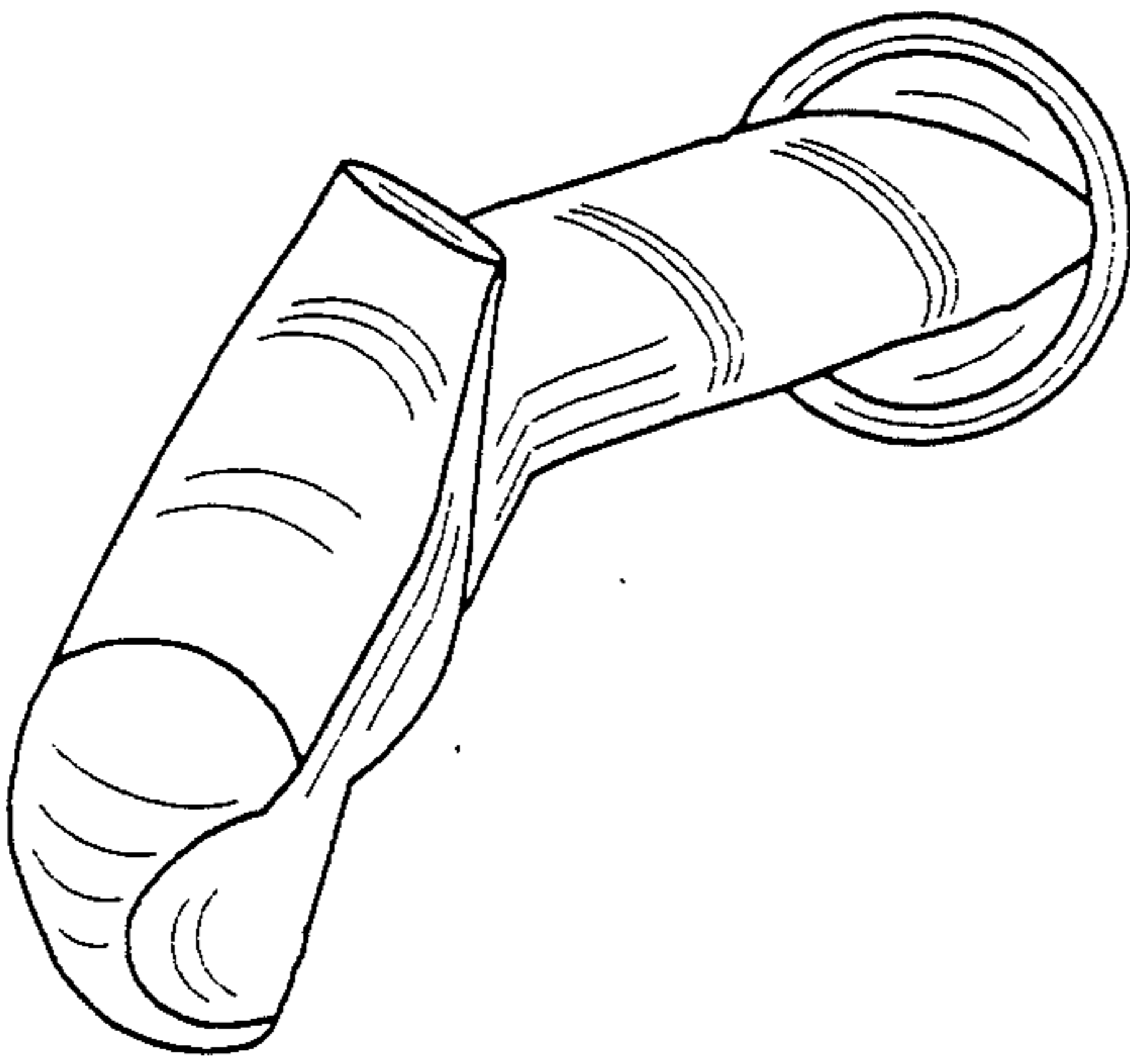

FIG. 6

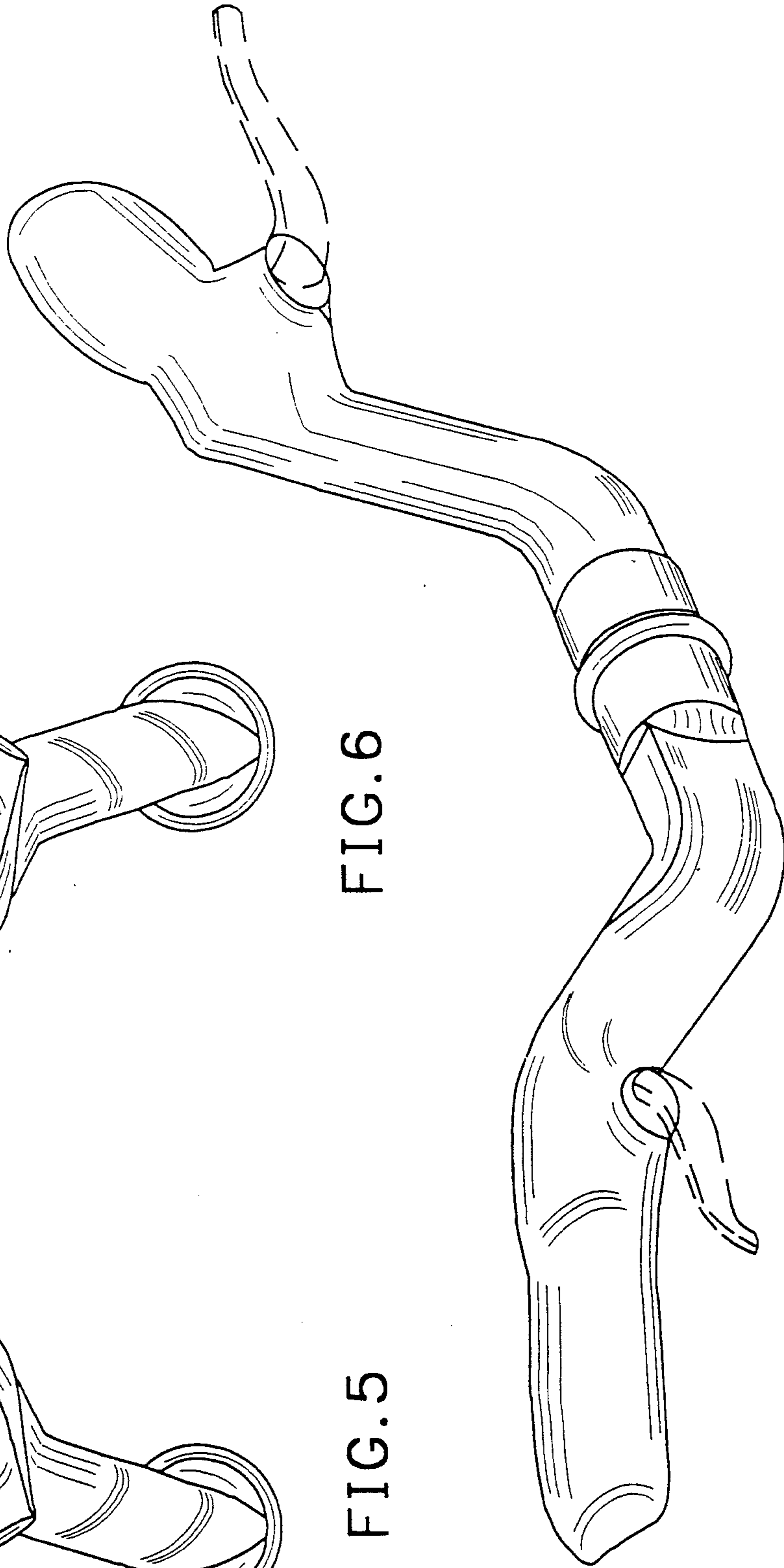

FIG. 7