



US00D345717S

United States Patent [19]

Molzon et al.

[11] Patent Number: **Des. 345,717**

[45] Date of Patent: **** Apr. 5, 1994**

[54] GOLF CAR

[75] Inventors: **William R. Molzon, Clarkson, Mich.;
James M. Criscuolo, Martinez, Ga.**

[73] Assignee: **Textron Inc., Providence, R.I.**

[**] Term: **14 Years**

[21] Appl. No.: **886,444**

[22] Filed: **May 20, 1992**

[52] U.S. Cl. **D12/16**

[58] Field of Search **296/186; 280/DIG. 5;
D12/16**

4,650,238	3/1987	Healey	296/37.7
4,772,064	9/1988	Moore	296/102
4,773,695	9/1988	Jones et al.	296/77.1
5,094,500	3/1992	Maypole et al.	296/102

OTHER PUBLICATIONS

1990 E-Z-Go Textron Product Catalog, pp. 1, 6, 9, 14, 22, 23, 24.

Primary Examiner—Wallace R. Burke

Assistant Examiner—M. Brown

Attorney, Agent, or Firm—Perman & Green

[57] CLAIM

The ornamental design for a golf car, as shown and described.

DESCRIPTION

FIG. 1 is a perspective view of a golf car showing our new design;
FIG. 2 is a top plan view thereof;
FIG. 3 is a side elevational view thereof, the opposite side being a mirror image;
FIG. 4 is a front elevational view thereof; and,
FIG. 5 is a rear elevational view thereof.

[56] References Cited

U.S. PATENT DOCUMENTS

D. 255,558	6/1980	Ekuan	D12/16
D. 320,580	10/1991	Kim	D12/16
D. 326,831	6/1992	Lanius et al.	D12/16
4,037,614	7/1977	Hines et al.	135/5 A
4,098,536	7/1978	Mills	296/78 R
4,334,692	6/1982	Lynch	280/79.1 A
4,533,013	8/1985	Hightower	180/210

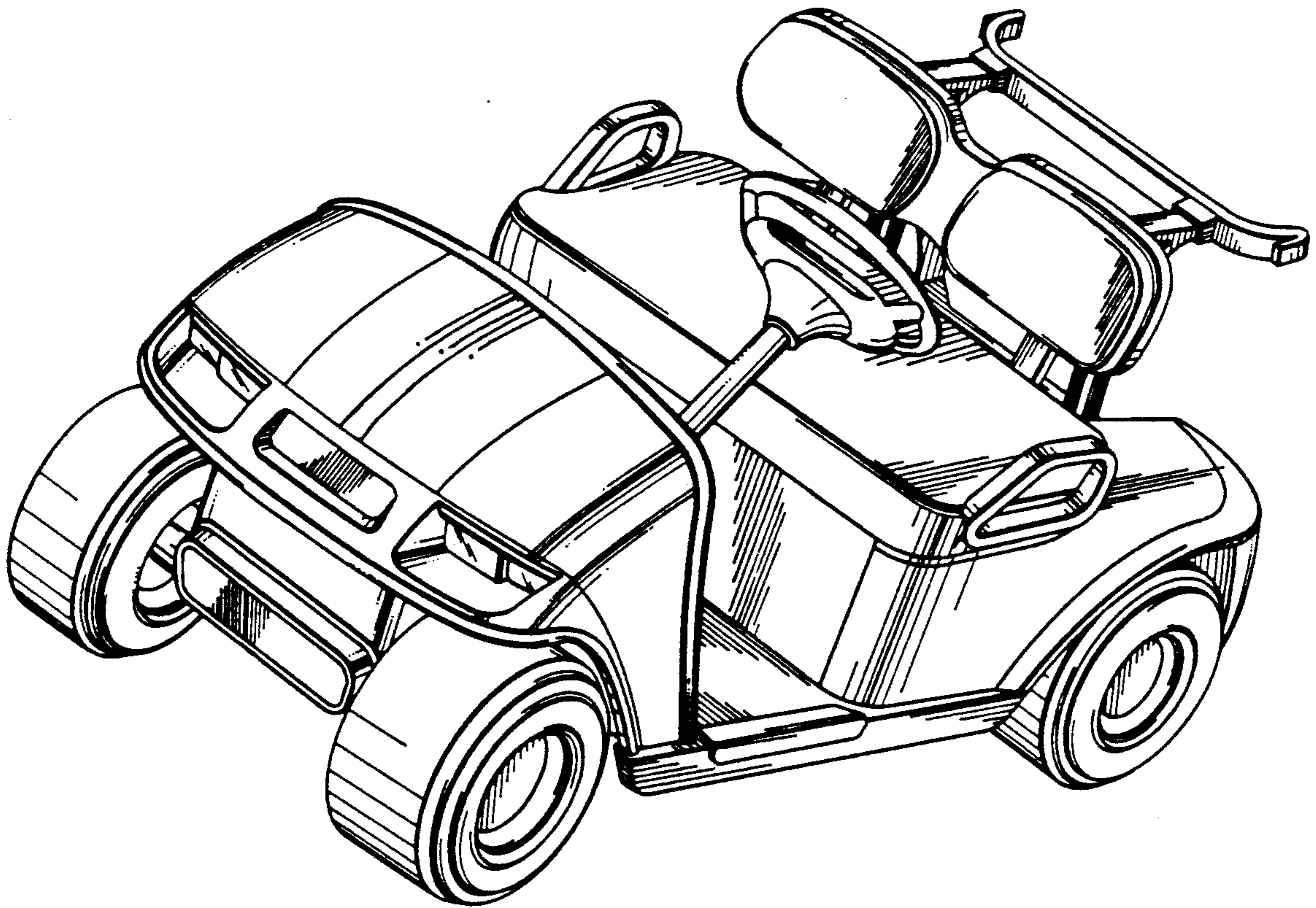

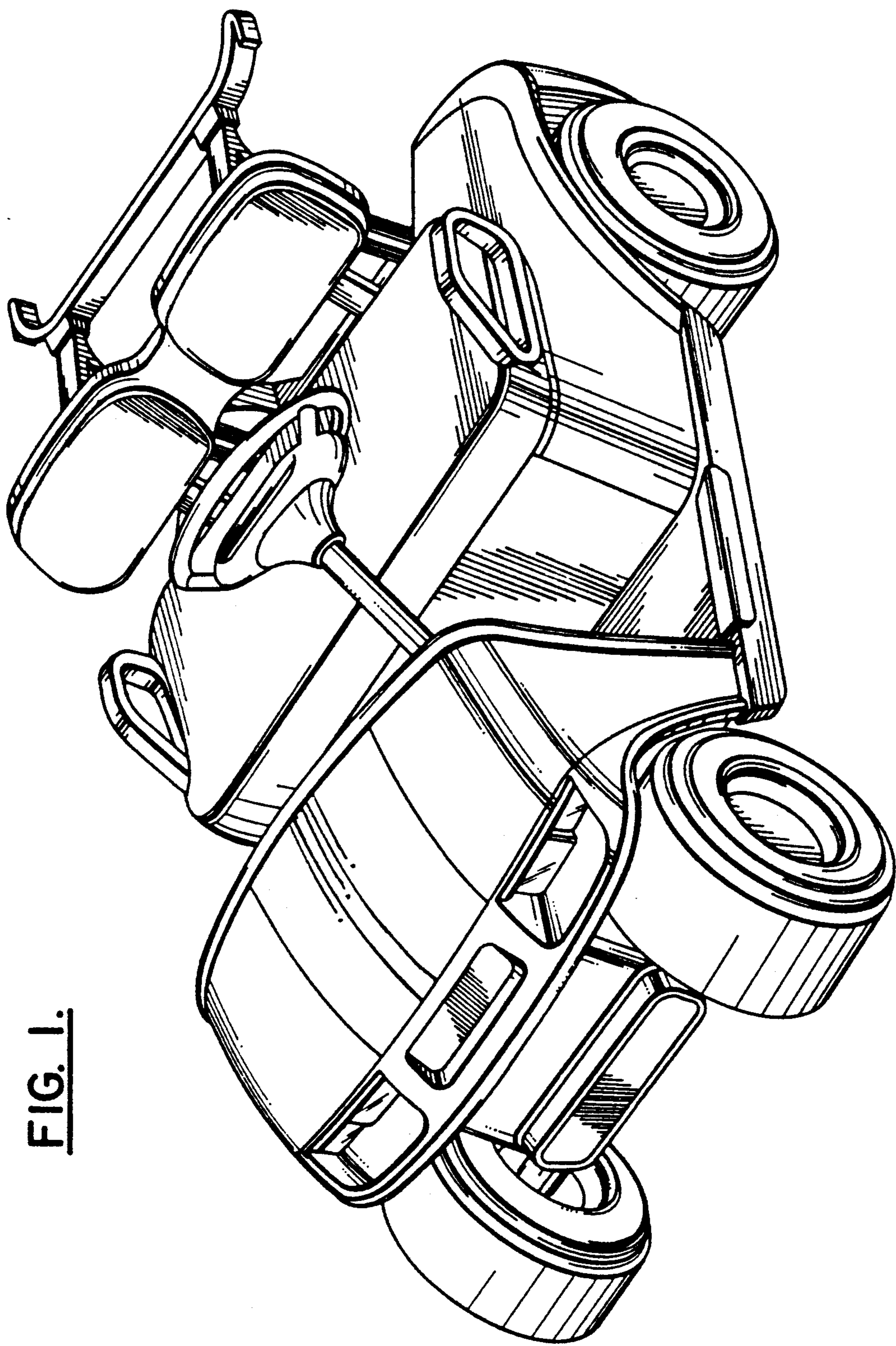

FIG. 1.

FIG. 2.

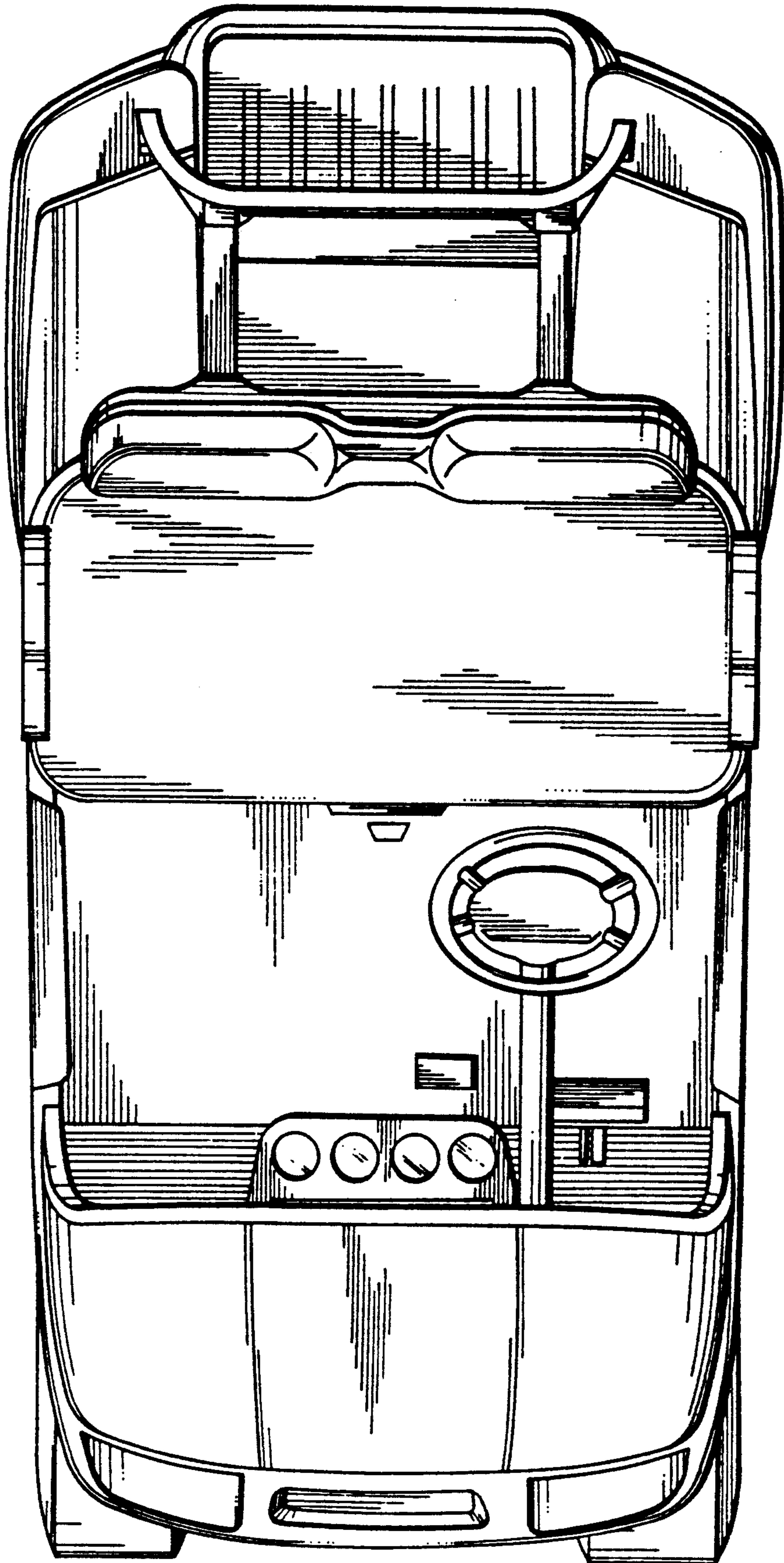

FIG. 3.

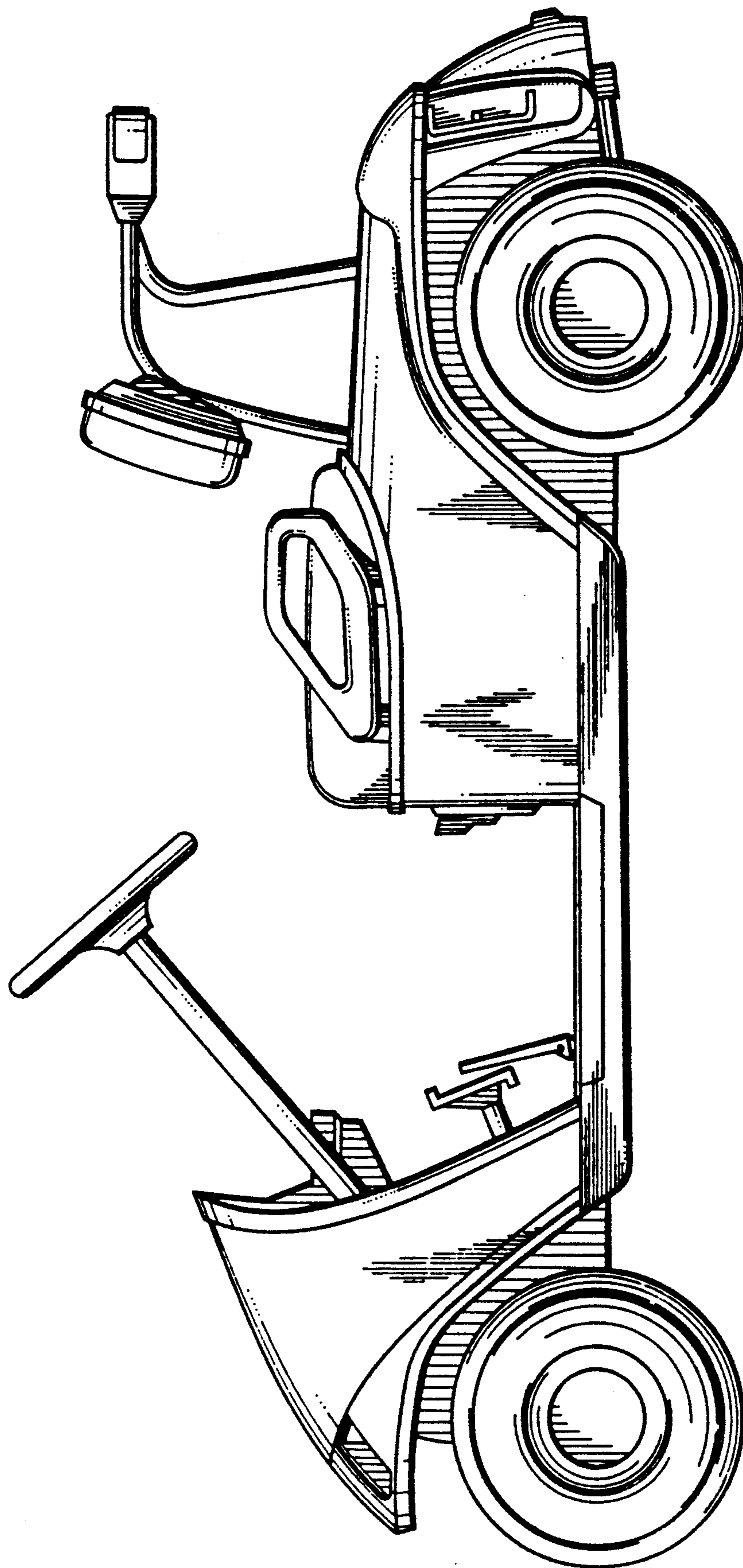

FIG. 4.

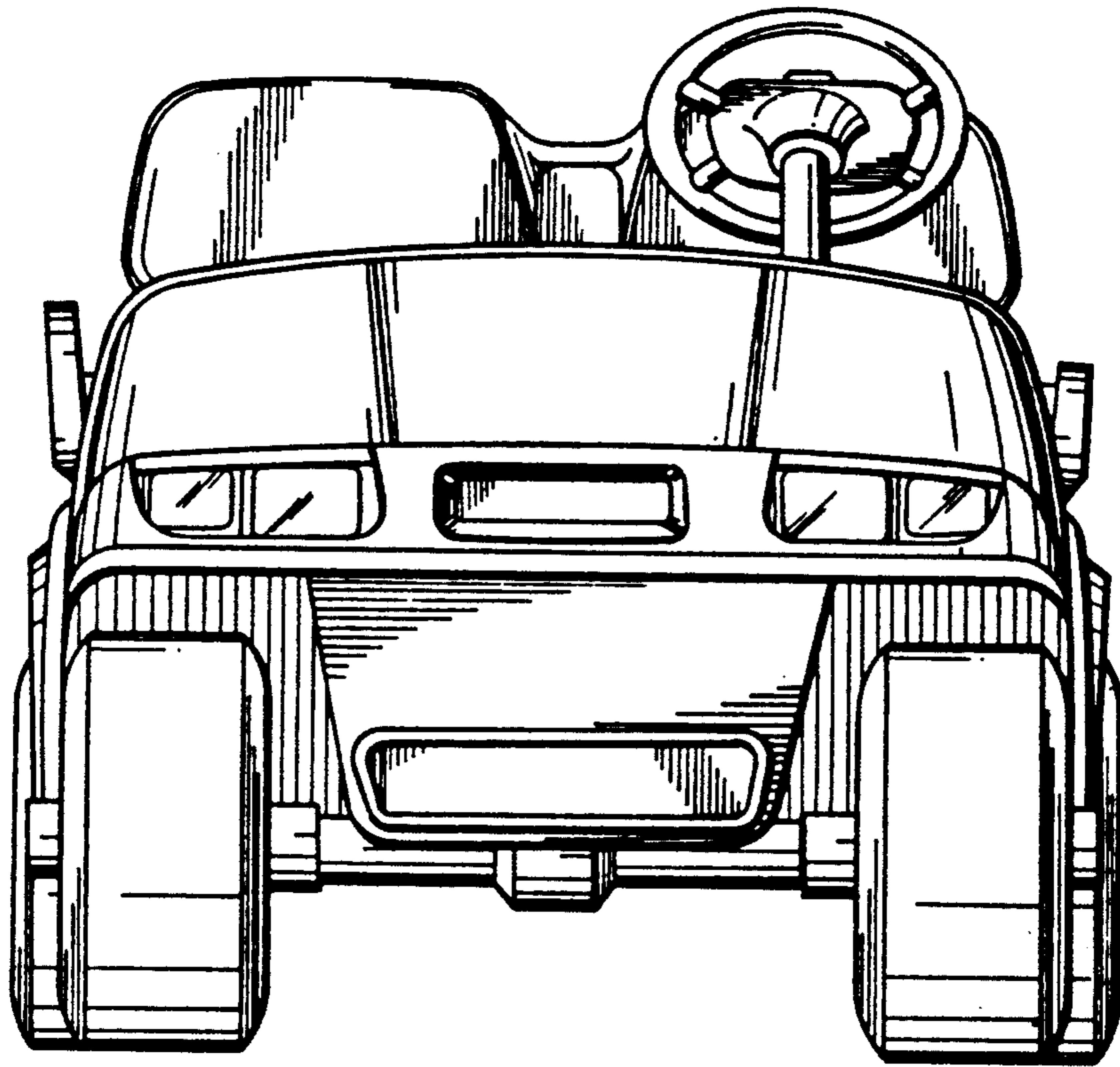

FIG. 5.

