



US00D345682S

United States Patent [19]

[11] Patent Number: **Des. 345,682**

Sasaki et al.

[45] Date of Patent: **** Apr. 5, 1994**

[54] **PORTABLE ELECTRIC SCREWDRIVER**

D. 329,580 9/1992 Sasaki et al. D8/68
D. 339,046 9/1993 Fushiya et al. D8/68

[75] Inventors: **Yuichiro Sasaki; Toshiaki Uchida,**
both of Katsuta, Japan

Primary Examiner—Alan P. Douglas
Assistant Examiner—J. H. Musgrove
Attorney, Agent, or Firm—Lowe, Price, LeBlanc &
Becker

[73] Assignee: **Hitachi Koki Company Limited,**
Tokyo, Japan

[**] Term: **14 Years**

[57] **CLAIM**

[21] Appl. No.: **3,348**

The ornamental design for portable electric screw-
driver, as shown.

[22] Filed: **Jan. 7, 1993**

DESCRIPTION

[52] U.S. Cl. **D8/68**

[58] Field of Search **D8/61, 68; 81/54, 57.11,**
81/57.14; 173/170; 408/124, 125

FIG. 1 is a front perspective view of the portable elec-
tric screwdriver;
FIG. 2 is a rear view thereof;
FIG. 3 is a right side view thereof;
FIG. 4 is a left side view thereof;
FIG. 5 is a front view thereof;
FIG. 6 is a bottom plan view thereof; and,
FIG. 7 is a top plan view thereof.

[56] **References Cited**

U.S. PATENT DOCUMENTS

D. 295,714 5/1988 Sasaki et al. D8/68
D. 320,917 10/1991 Fushiya et al. D8/68

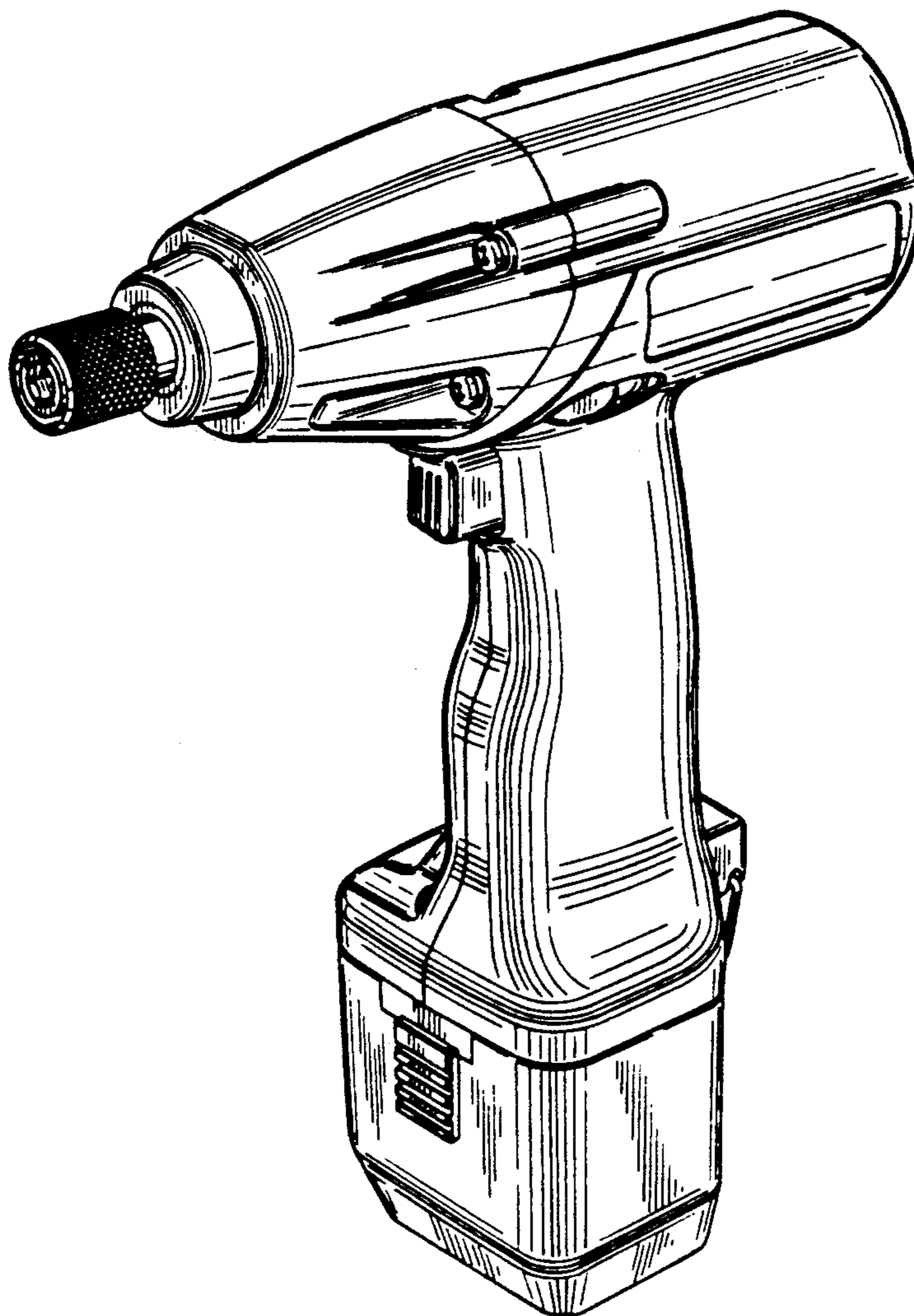

FIG. 1

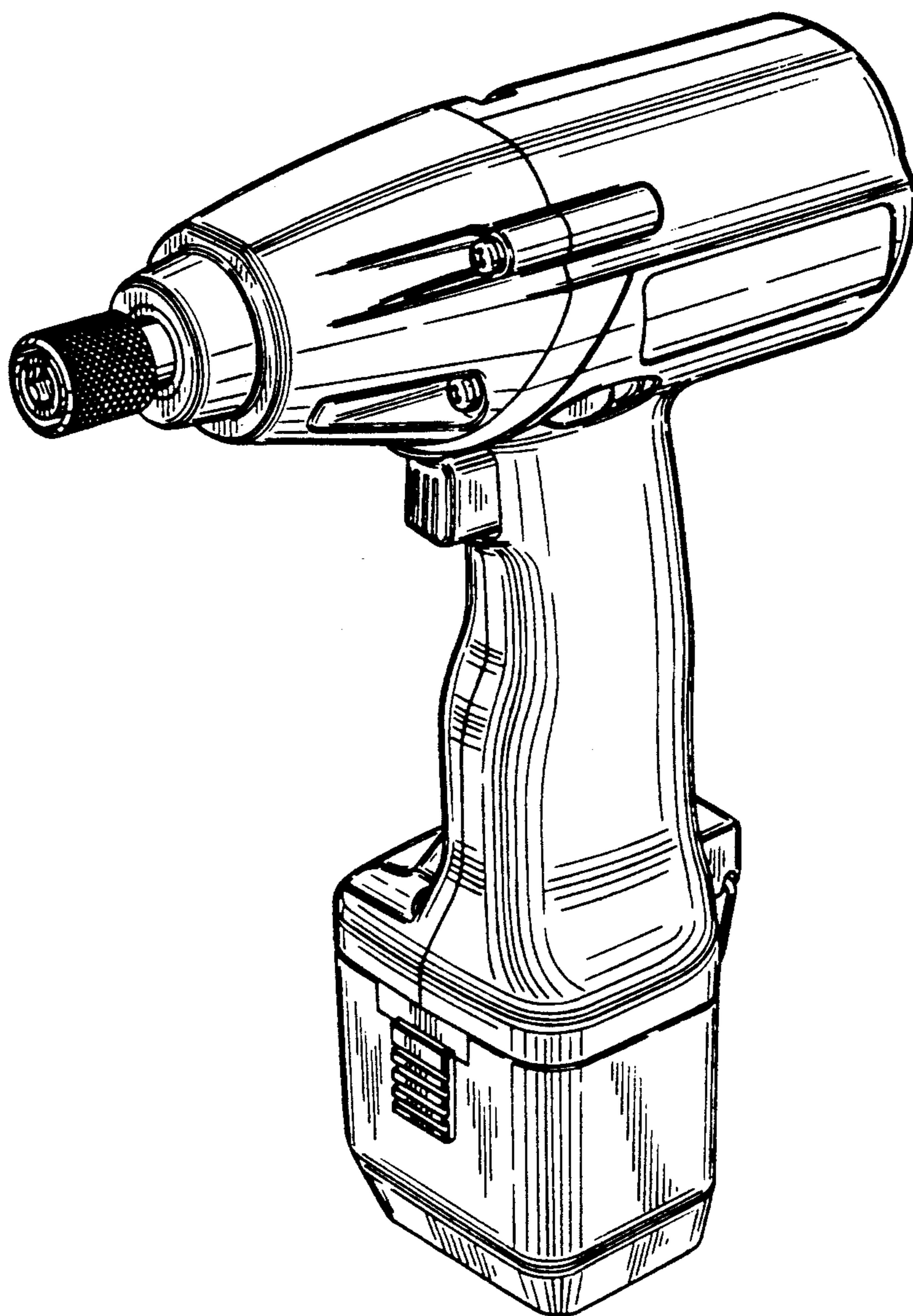

FIG. 2

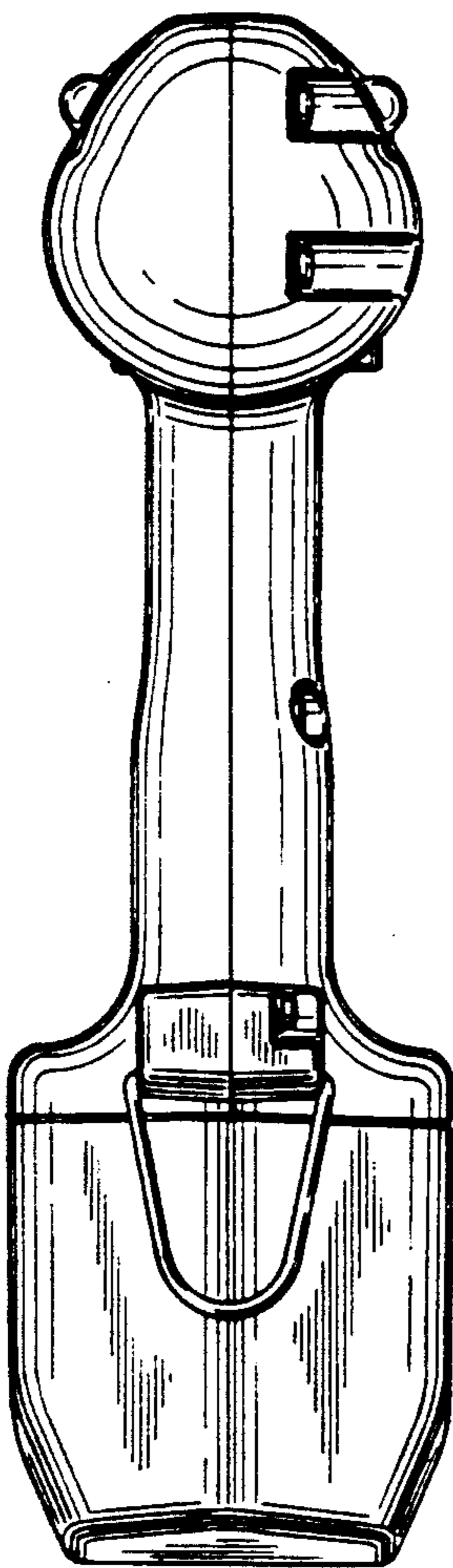

FIG. 3

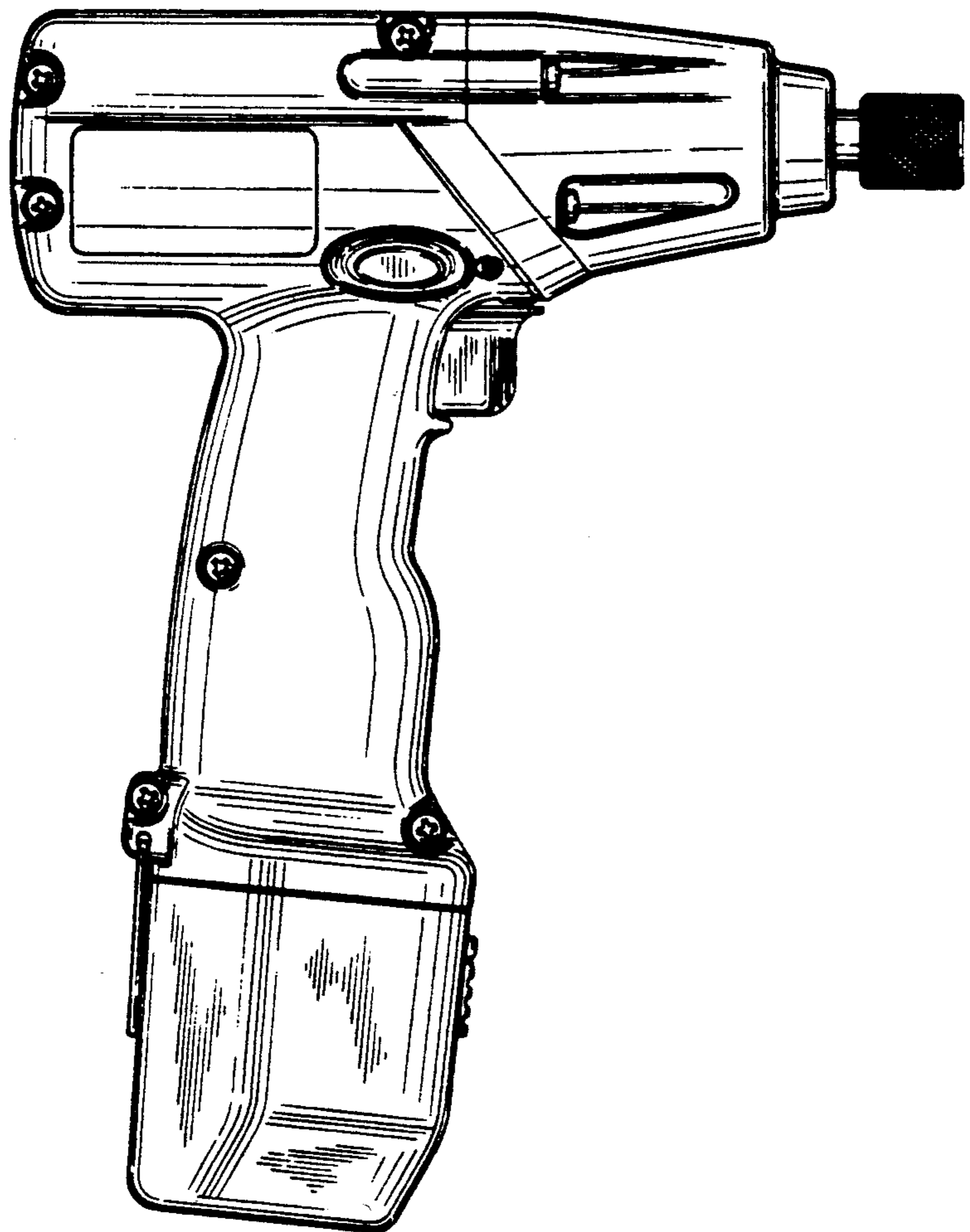

FIG. 4

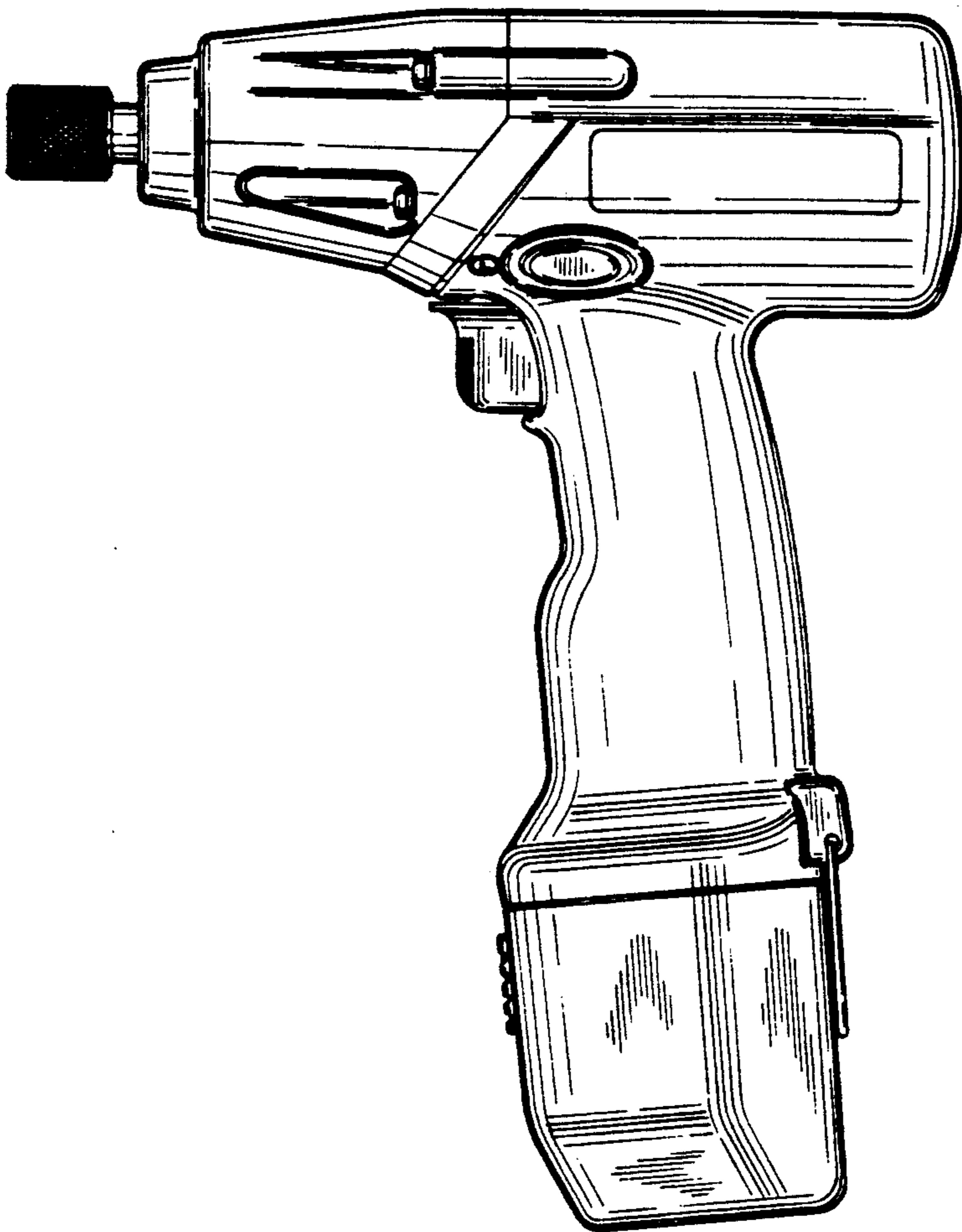

FIG. 5

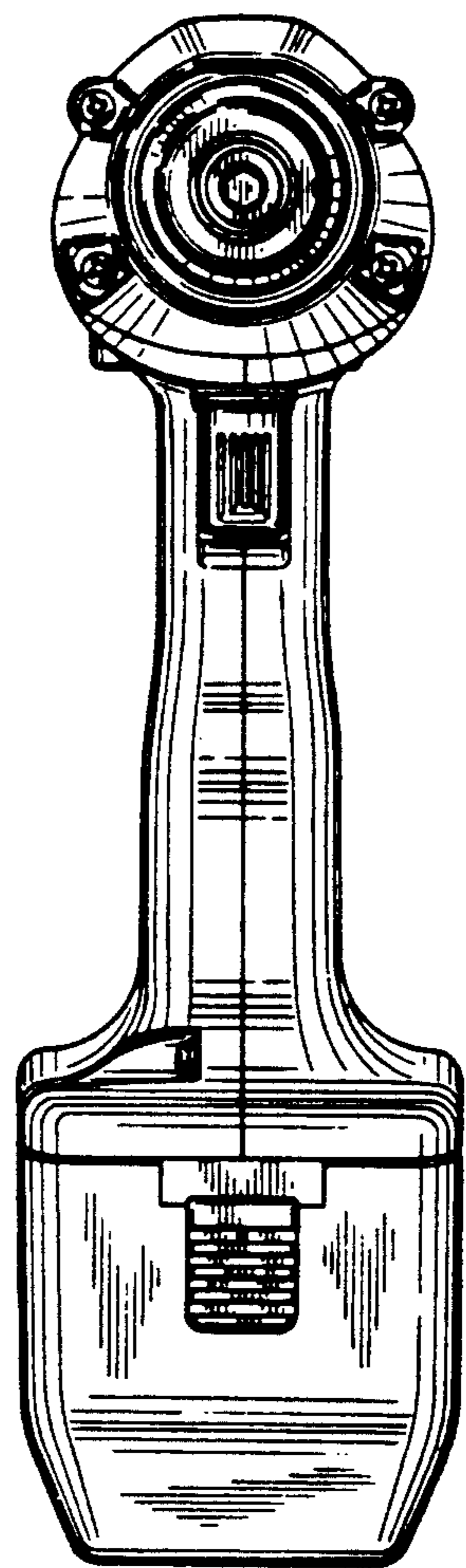

FIG. 6

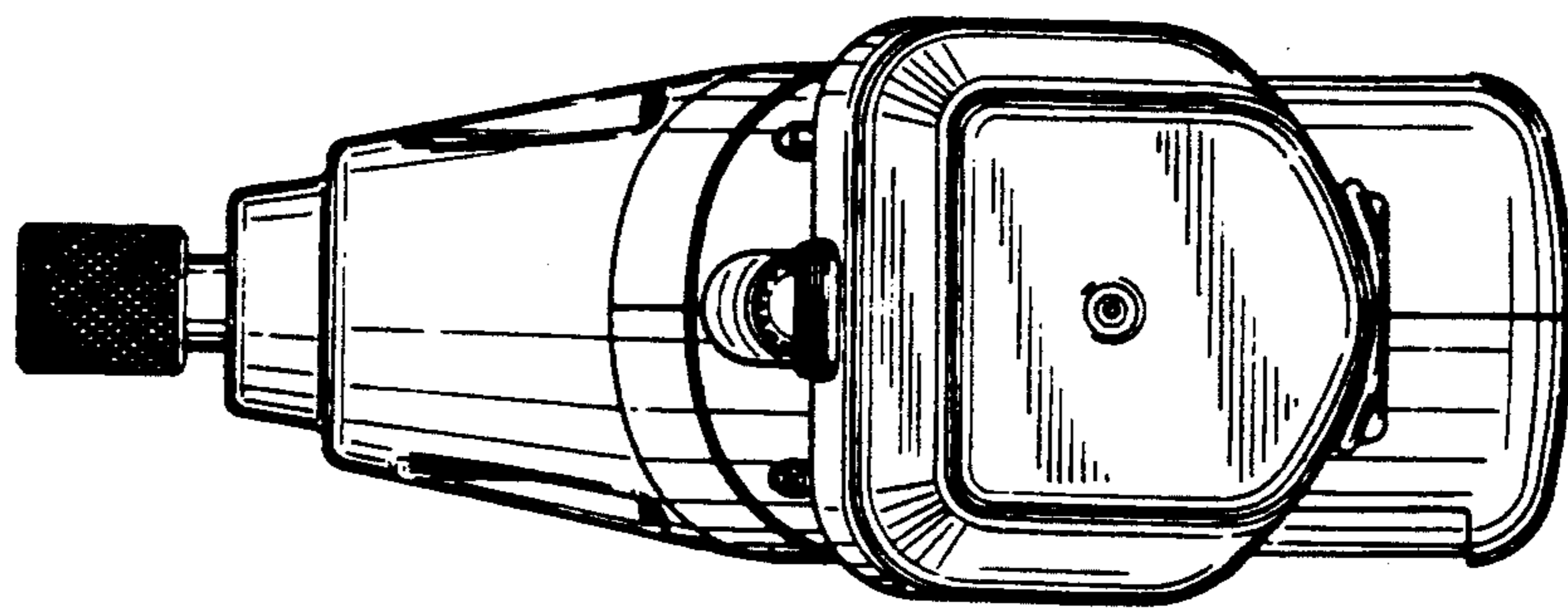

FIG. 7

