



US00D345542S

United States Patent [19]
Duncan

[11] **Patent Number: Des. 345,542**
[45] **Date of Patent: ** Mar. 29, 1994**

[54] **NAUTICAL CRAFT**
[76] **Inventor: Ian J. Duncan, 5 Avenue de la Porte Neuve, 17000 La Rochelle, France**

3,966,143 6/1976 Smith 244/16
4,685,641 8/1987 Kirsch et al. 114/282
4,926,773 5/1990 Manor 114/274
4,955,312 9/1990 Magazzu 114/280

[**] **Term: 14 Years**
[21] **Appl. No.: 814**
[22] **Filed: Oct. 26, 1992**

Primary Examiner—Kay H. Chin
Attorney, Agent, or Firm—Kuhn and Muller

[30] **Foreign Application Priority Data**
Apr. 27, 1992 [FR] France 92 922820
[52] **U.S. Cl. D12/309; D12/300; D12/324**
[58] **Field of Search 244/16, 105; 114/280, 114/282, 274, 272; D12/300, 309, 319, 324, 331**

[57] **CLAIM**
The ornamental design for a nautical craft, as shown and described.

[56] **References Cited**
U.S. PATENT DOCUMENTS
3,964,417 6/1976 Williams et al. 114/274

DESCRIPTION
FIG. 1 is a front perspective view of the nautical craft; FIG. 2 is a rear perspective view thereof; FIG. 3 is a right side elevational view of the nautical craft, the left side being a mirror image thereof; FIG. 4 is a front elevational view thereof; FIG. 5 is a rear elevational view thereof; FIG. 6 is a top plan view thereof; and, FIG. 7 is a bottom plan view thereof.

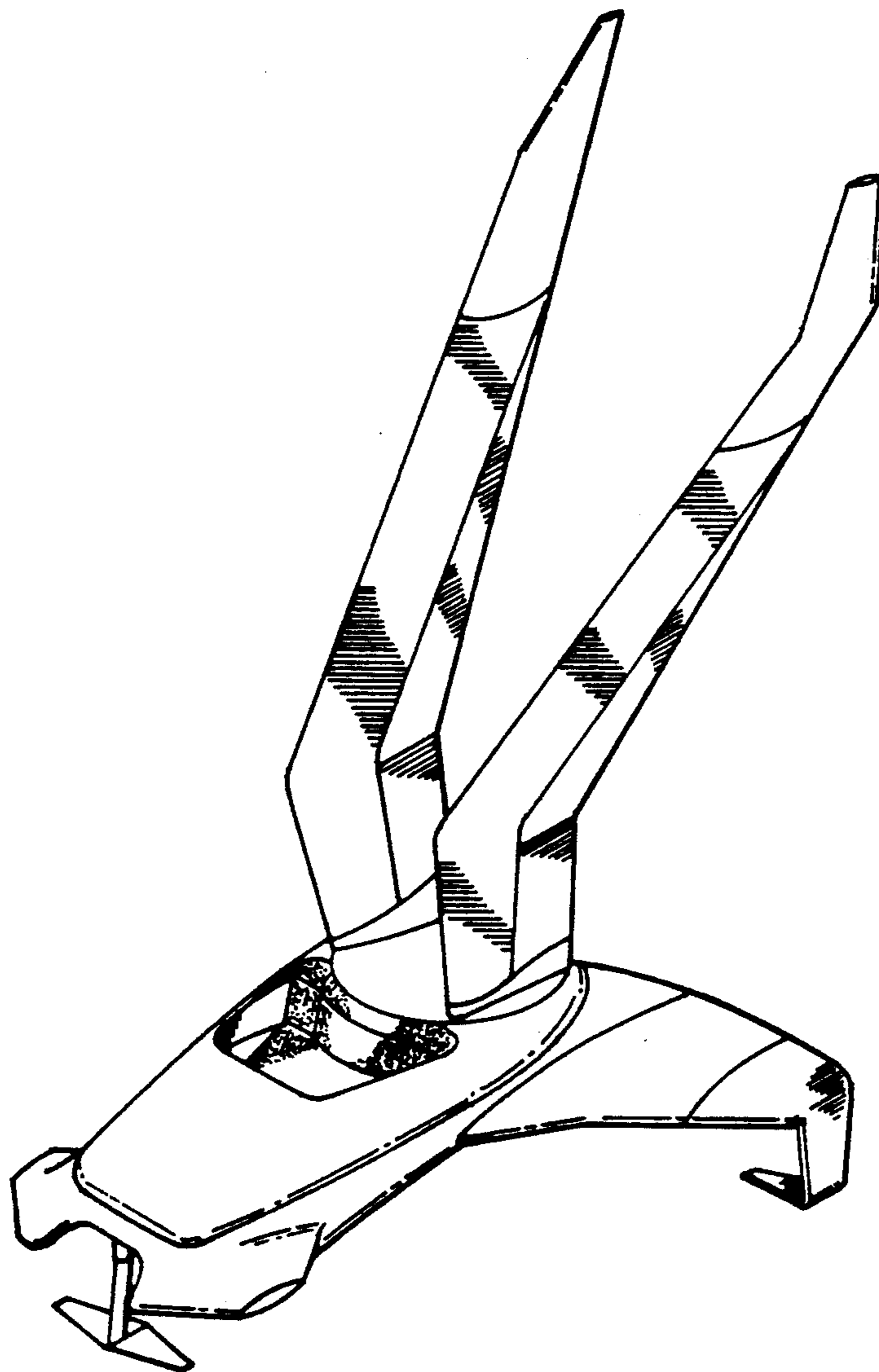

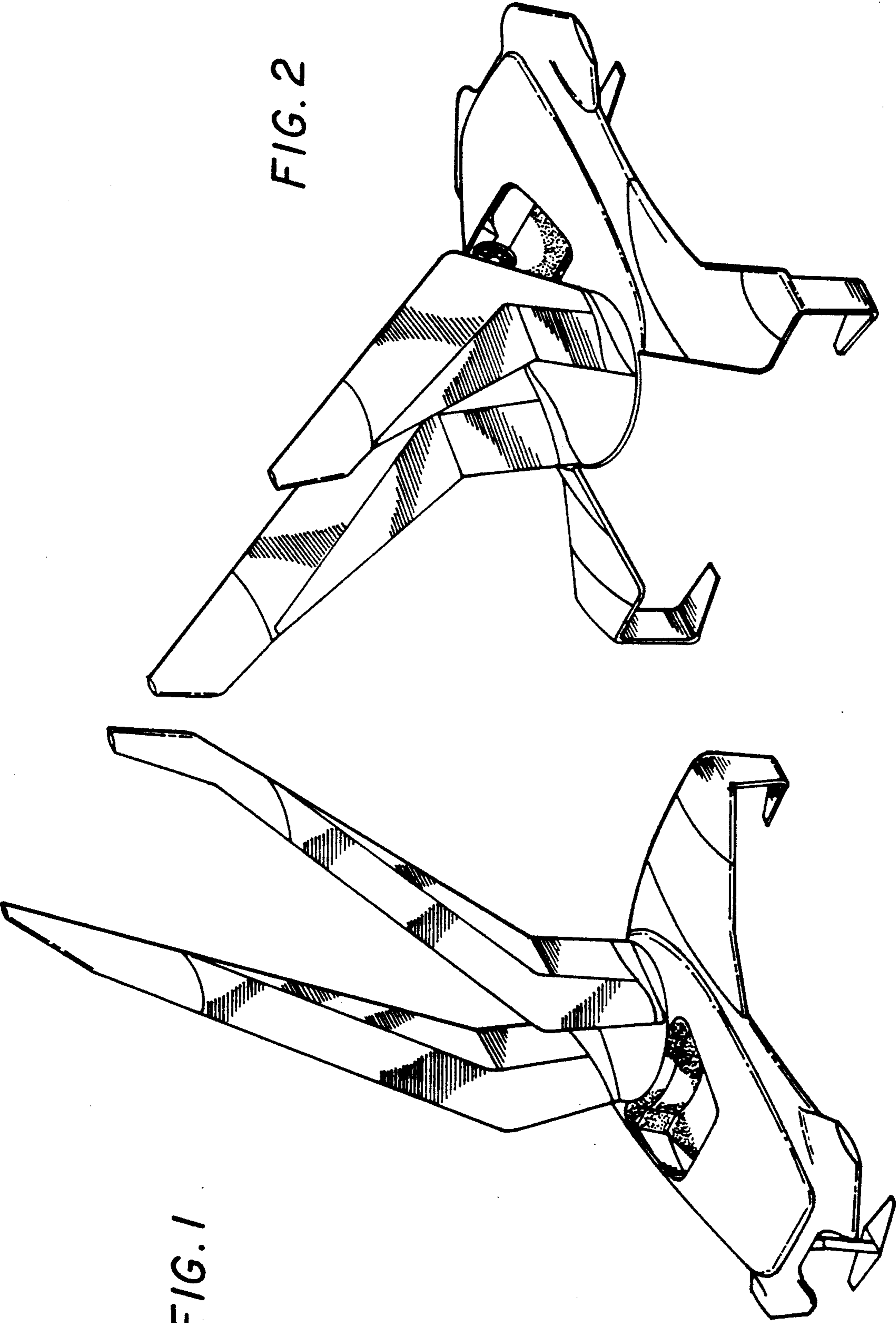

FIG. 2

FIG. 1

FIG. 4

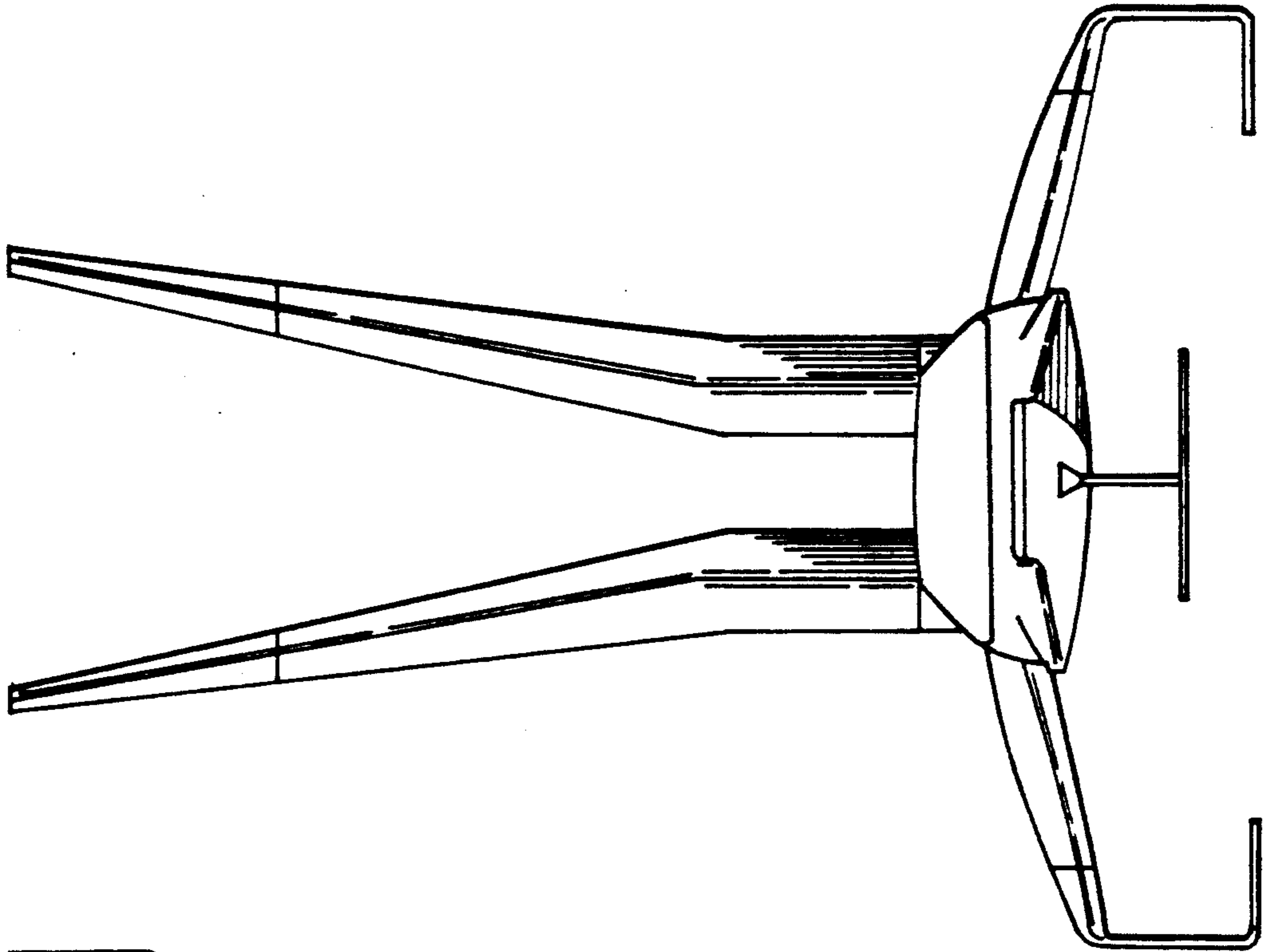

FIG. 3

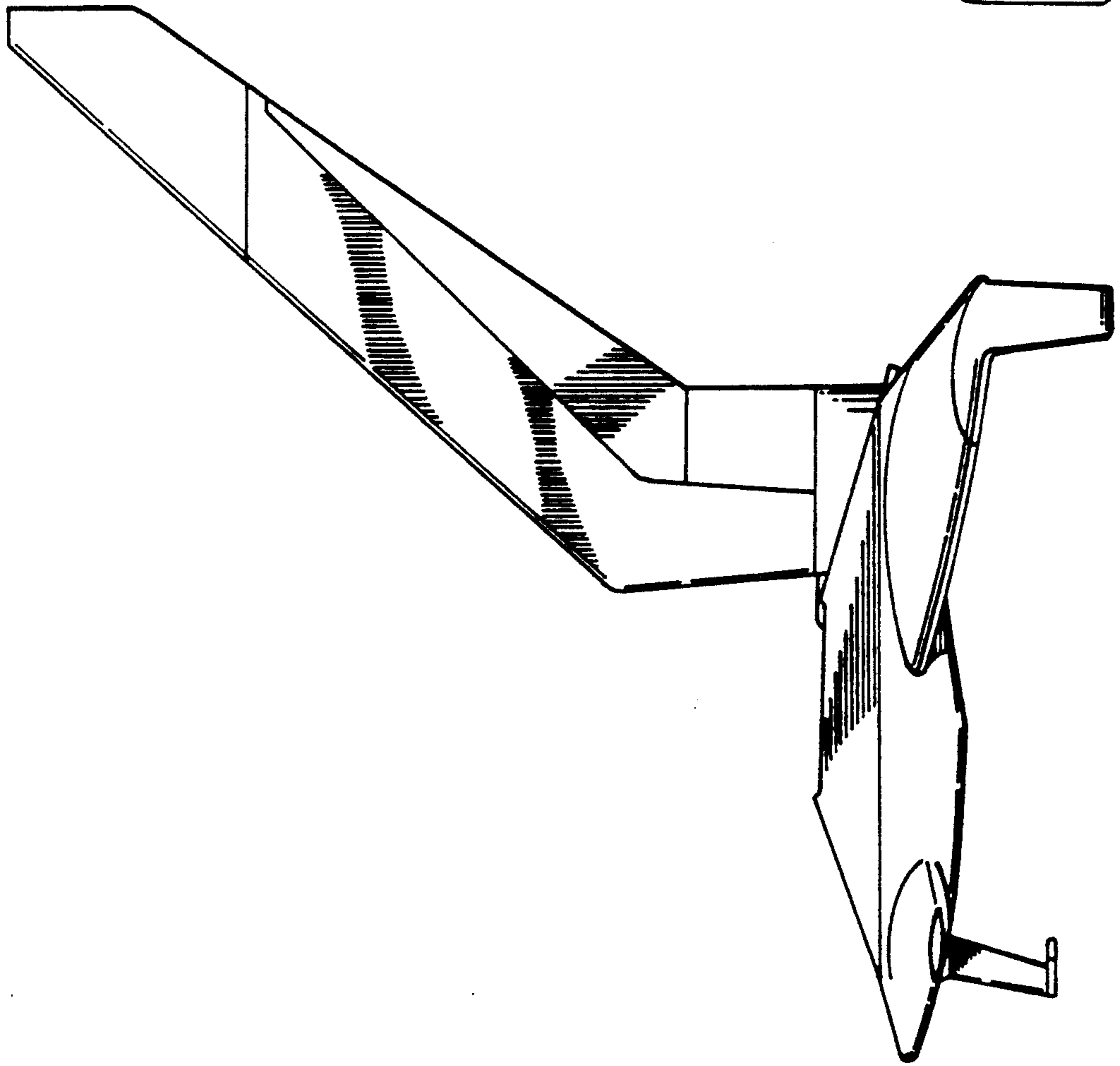

FIG. 6

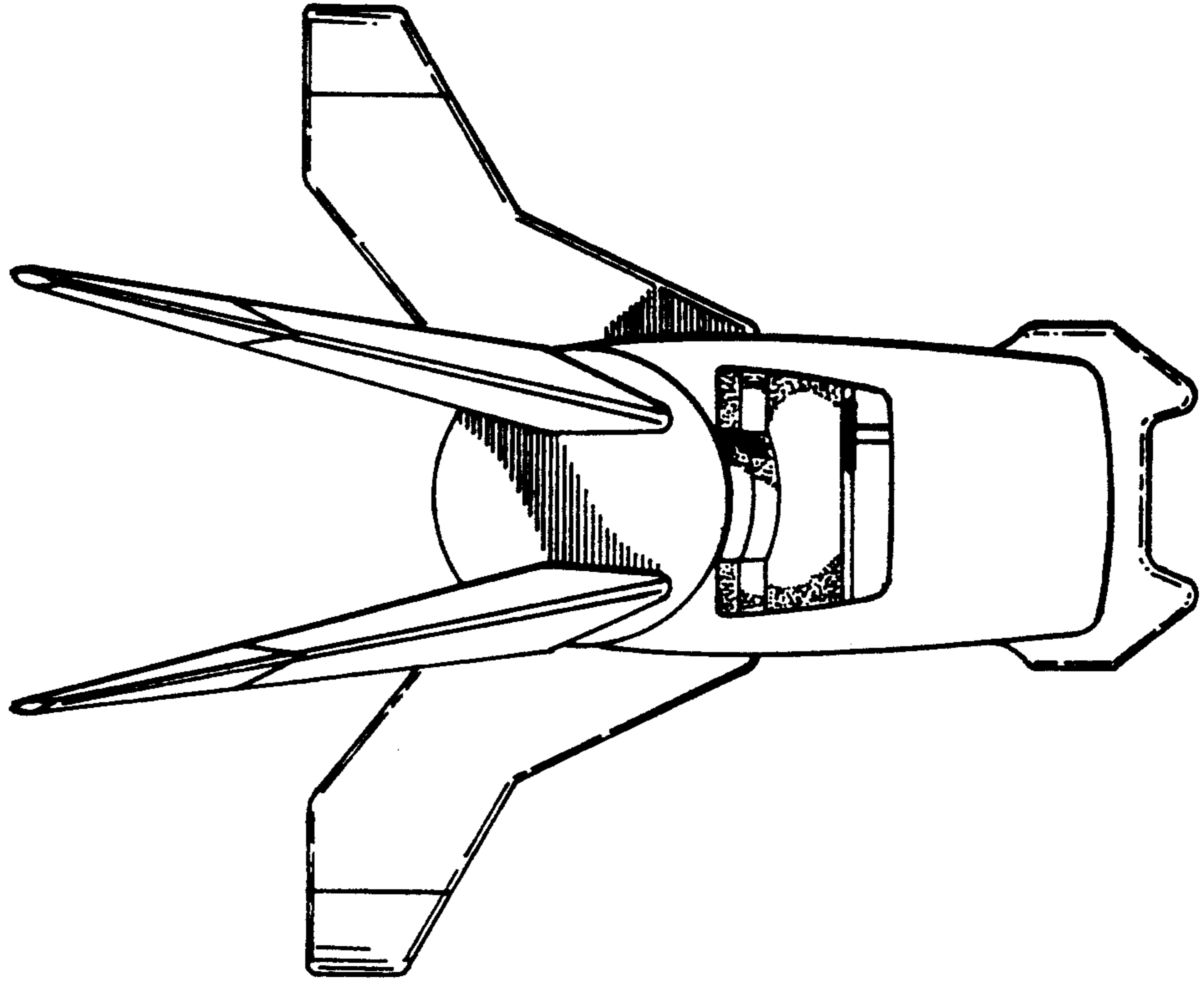

FIG. 5

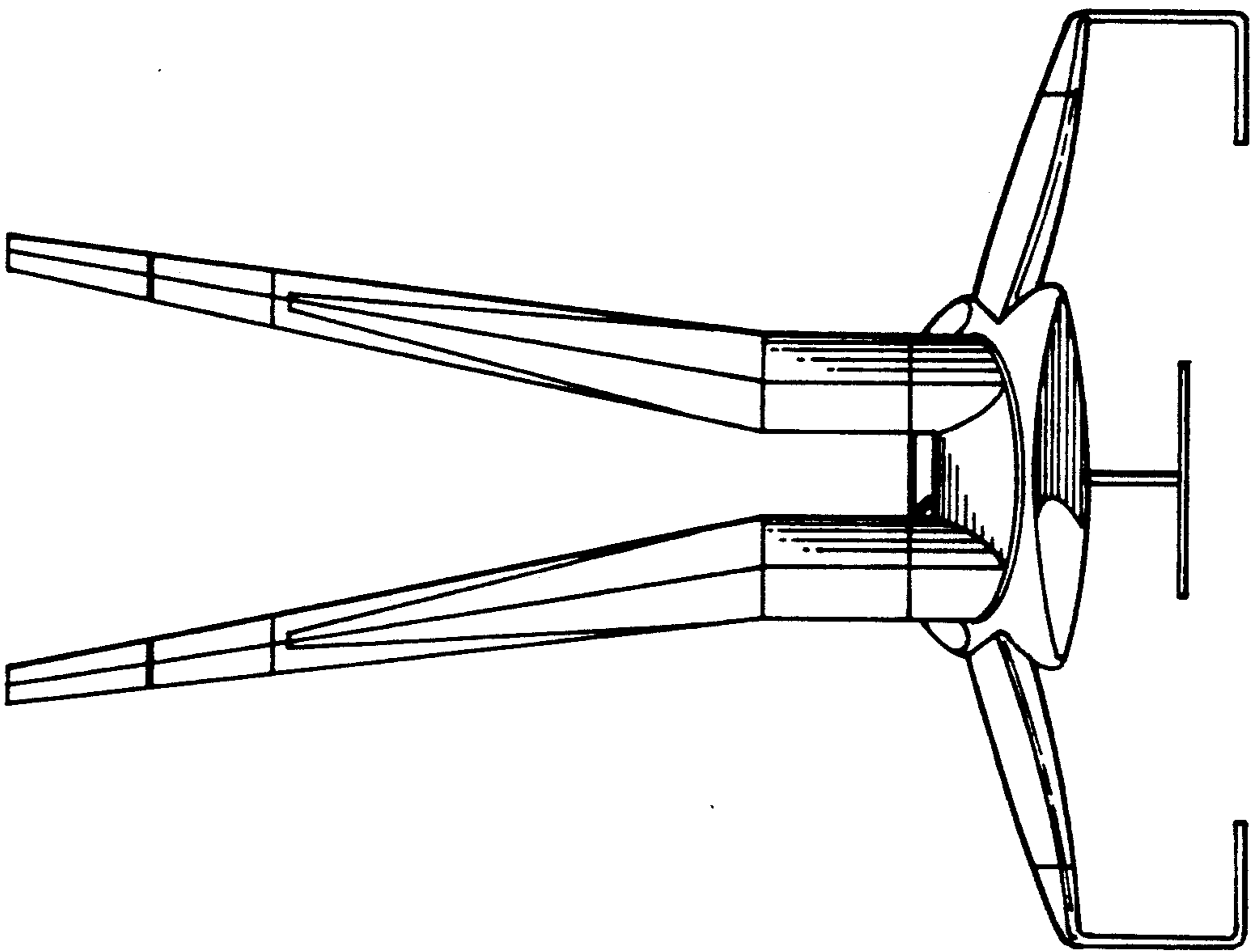

FIG. 7

