



US00D345540S

United States Patent [19]

[11] Patent Number: **Des. 345,540**

Allen

[45] Date of Patent: **** Mar. 29, 1994**

[54] STEERING WHEEL ASSEMBLY WITH COMMUNICATION KEYBOARD

DESCRIPTION

[76] Inventor: **Dillis V. Allen**, 1080 Nerge Rd., Ste. 205, Elk Grove Village, Ill. 60007

FIG. 1 is a perspective view;

FIG. 2 is a right side view;

FIG. 3 is a left side view;

FIG. 4 is a rear view;

FIG. 5 is a bottom view;

FIG. 6 is a top view;

[**] Term: **14 Years**

[21] Appl. No.: **702,690**

[22] Filed: **May 20, 1991**

[52] U.S. Cl. **D12/176**

[58] Field of Search **74/552, 484 R; D12/175, D12/176**

FIG. 7 is a perspective view of a second embodiment, the sole difference being in the shape of the keyboard housing and the arrangement of the buttons thereon, all remaining portions of the steering wheel assembly being the same as the embodiment shown in FIGS. 1 thru 6; FIG. 8 is a perspective view of a third embodiment; FIG. 9 is a right side view of the third embodiment; FIG. 10 is a left side view of the third embodiment; FIG. 11 is a rear view of the third embodiment; FIG. 12 is a bottom view of the third embodiment; and, FIG. 13 is a top view of the third embodiment.

[56] References Cited

U.S. PATENT DOCUMENTS

- 4,625,578 12/1986 Nishijima 74/552
- 4,655,308 4/1987 Kraus et al. 74/552
- 4,946,194 8/1990 Maeda et al. 74/552

FOREIGN PATENT DOCUMENTS

- 3018247 11/1981 Fed. Rep. of Germany 74/484 R
- 171381 7/1990 Japan 74/552

Primary Examiner—James M. Gandy

Portions of the steering wheel assembly have been broken away in FIGS. 4, 5 and 11, and the outer rim thereof is shown in section in FIGS. 2, 3, 9 and 10, and the right and left spokes of said assembly are omitted in FIGS. 2 and 8 and 3 and 9 of the drawing respectively for clarity of illustration.

[57] CLAIM

The ornamental design for a steering wheel assembly with communication keyboard, as shown and described.

The broken line showing of a fragmentary portion of a steering column in the drawing is for illustrative purposes only and forms no part of the claimed design.

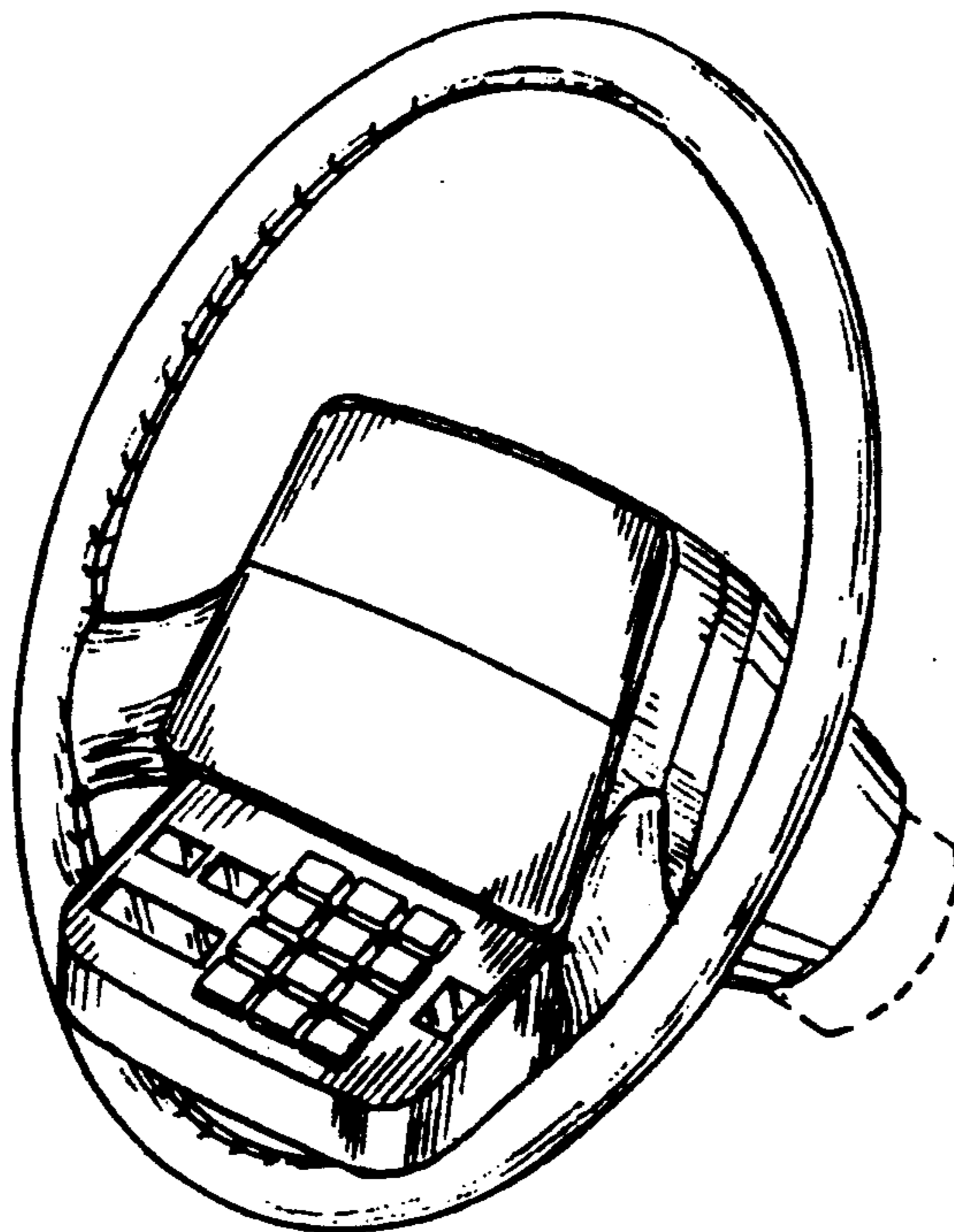

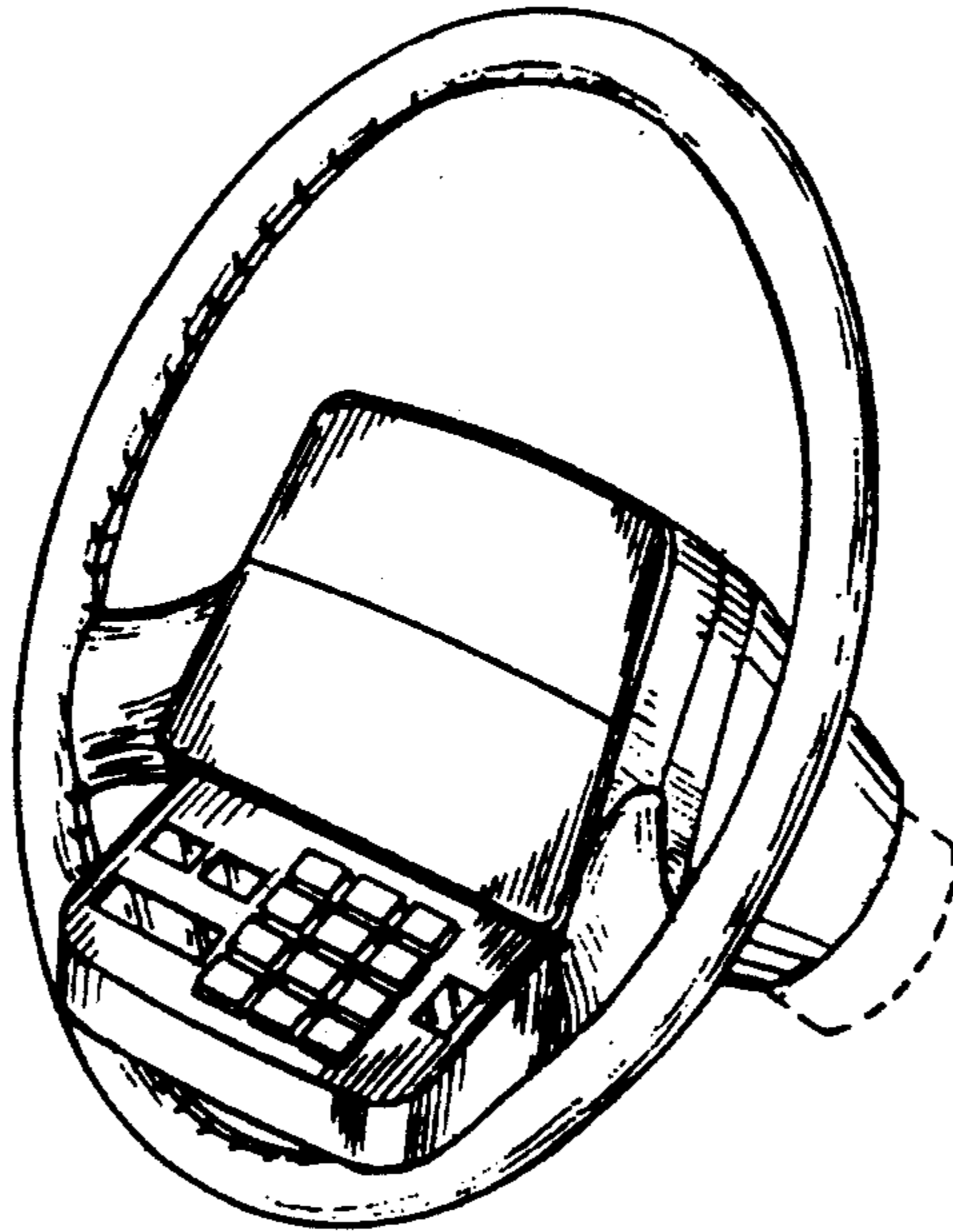

Fig. 1

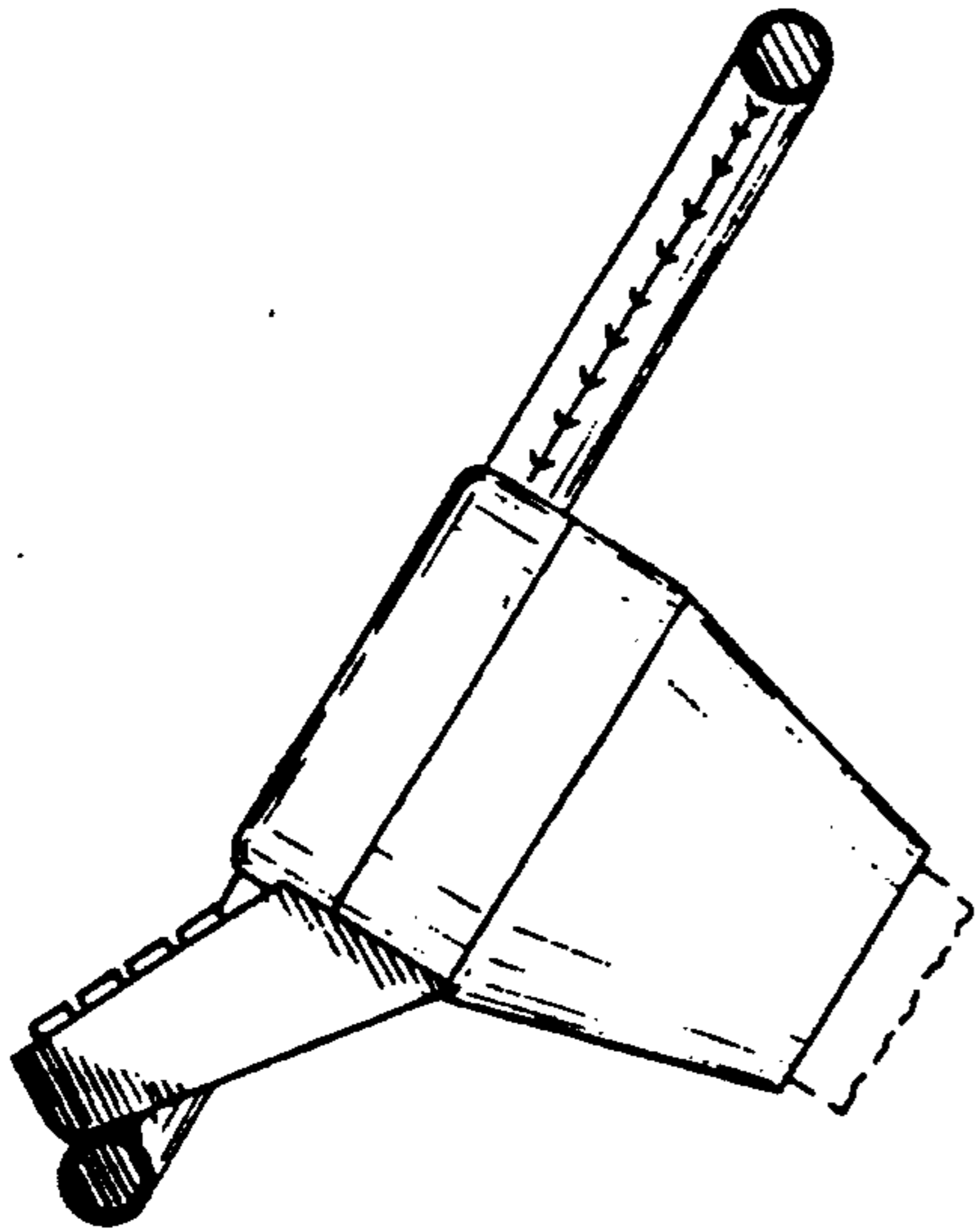

Fig. 2

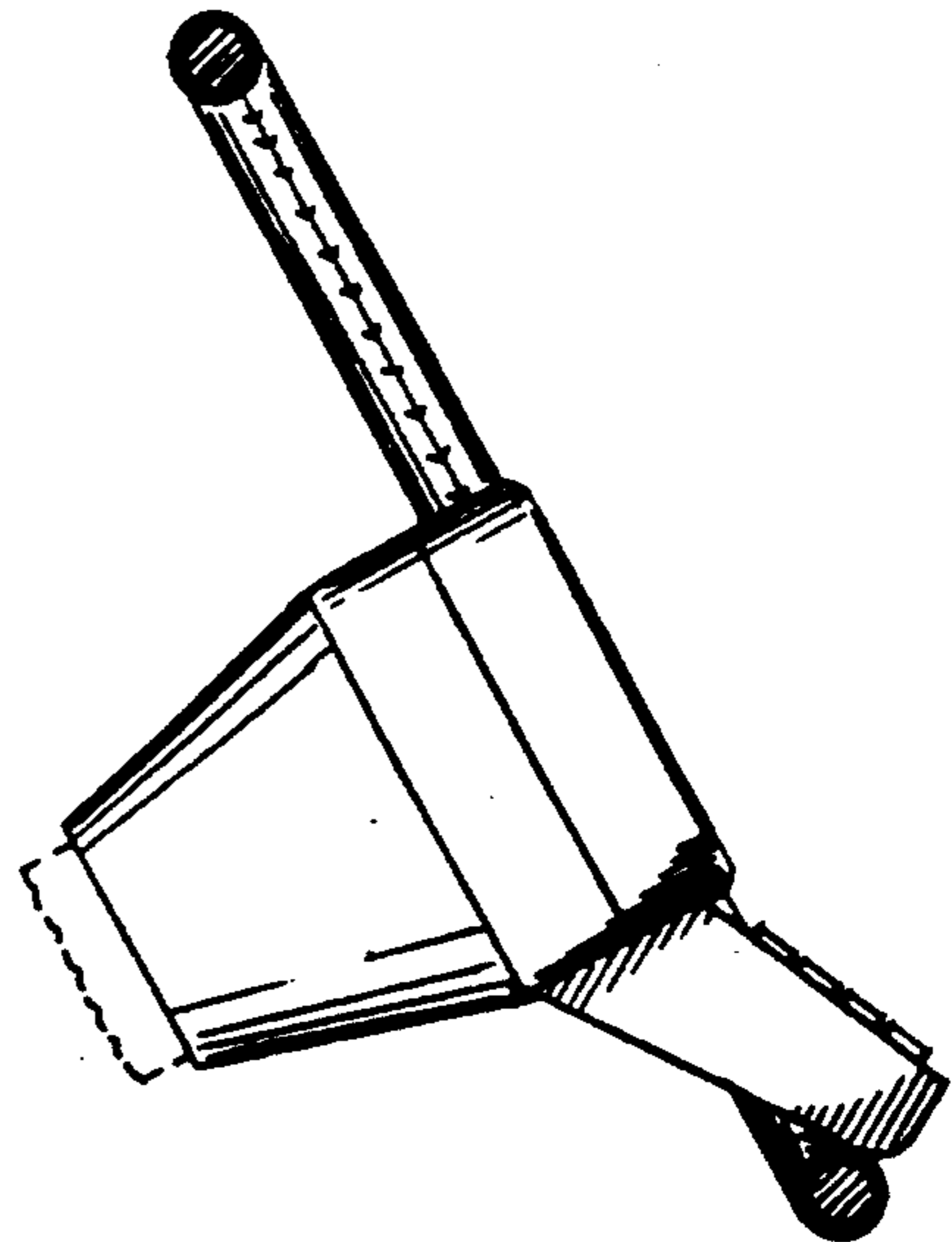

Fig. 3

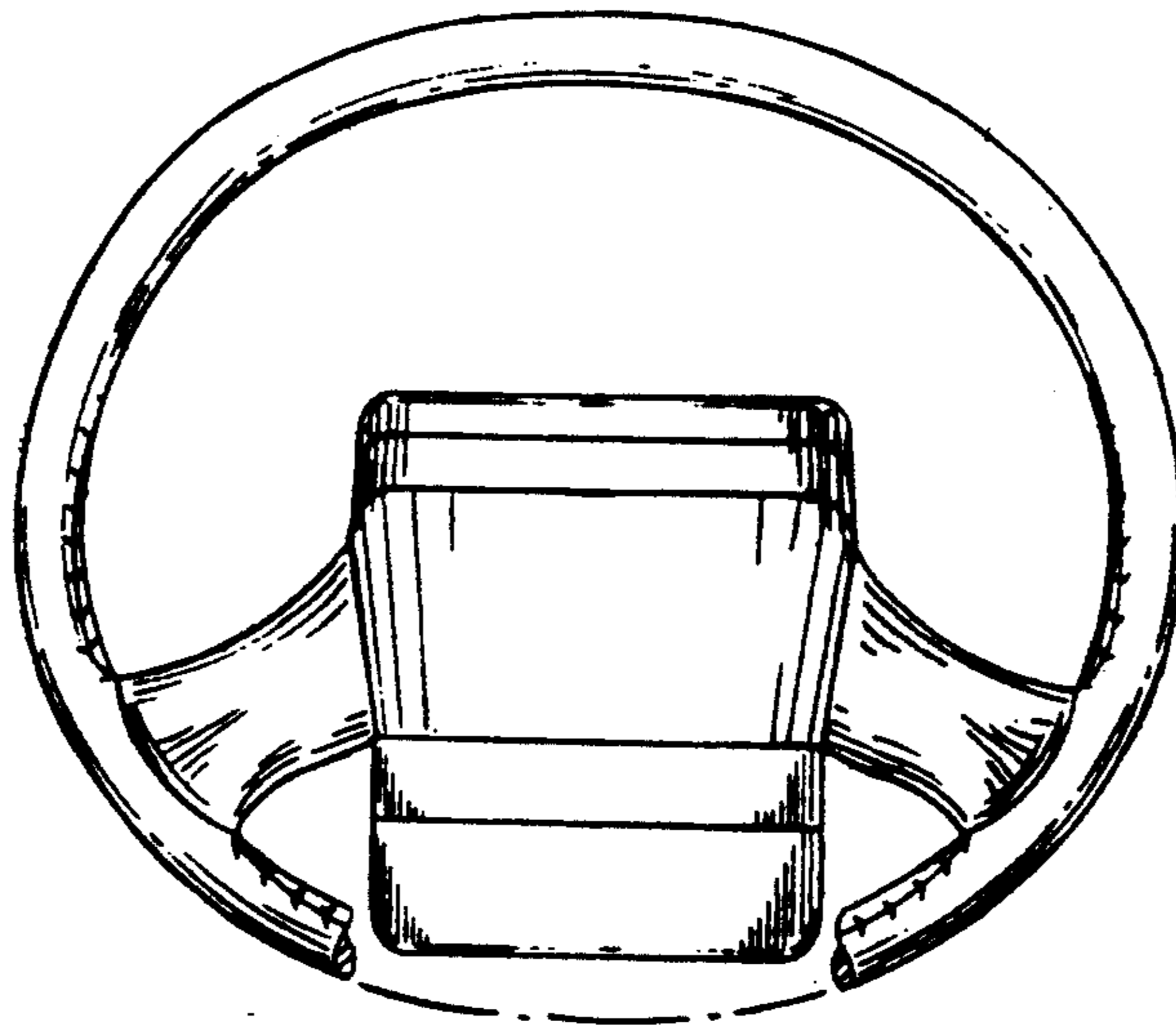

Fig. 4

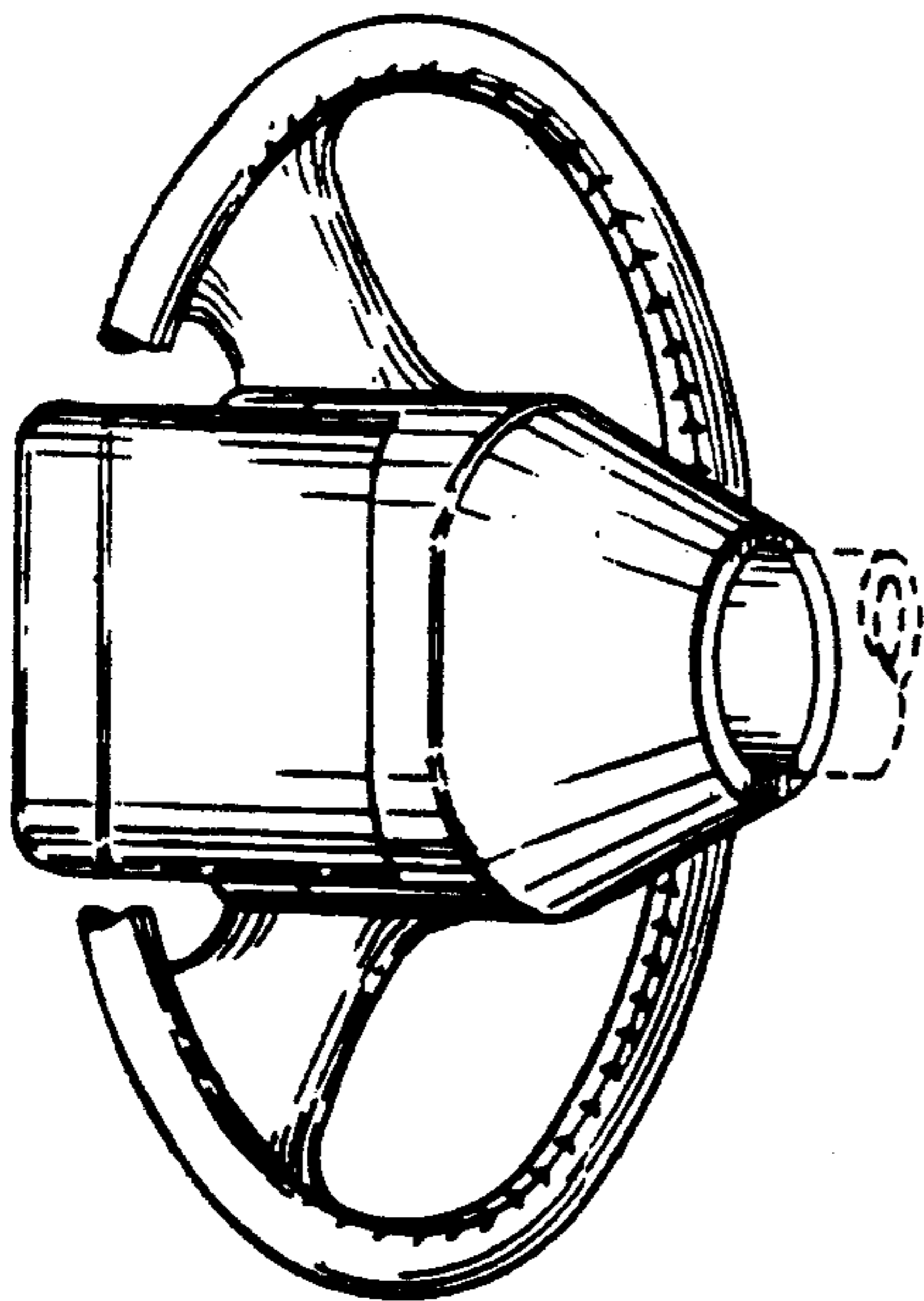

Fig. 5

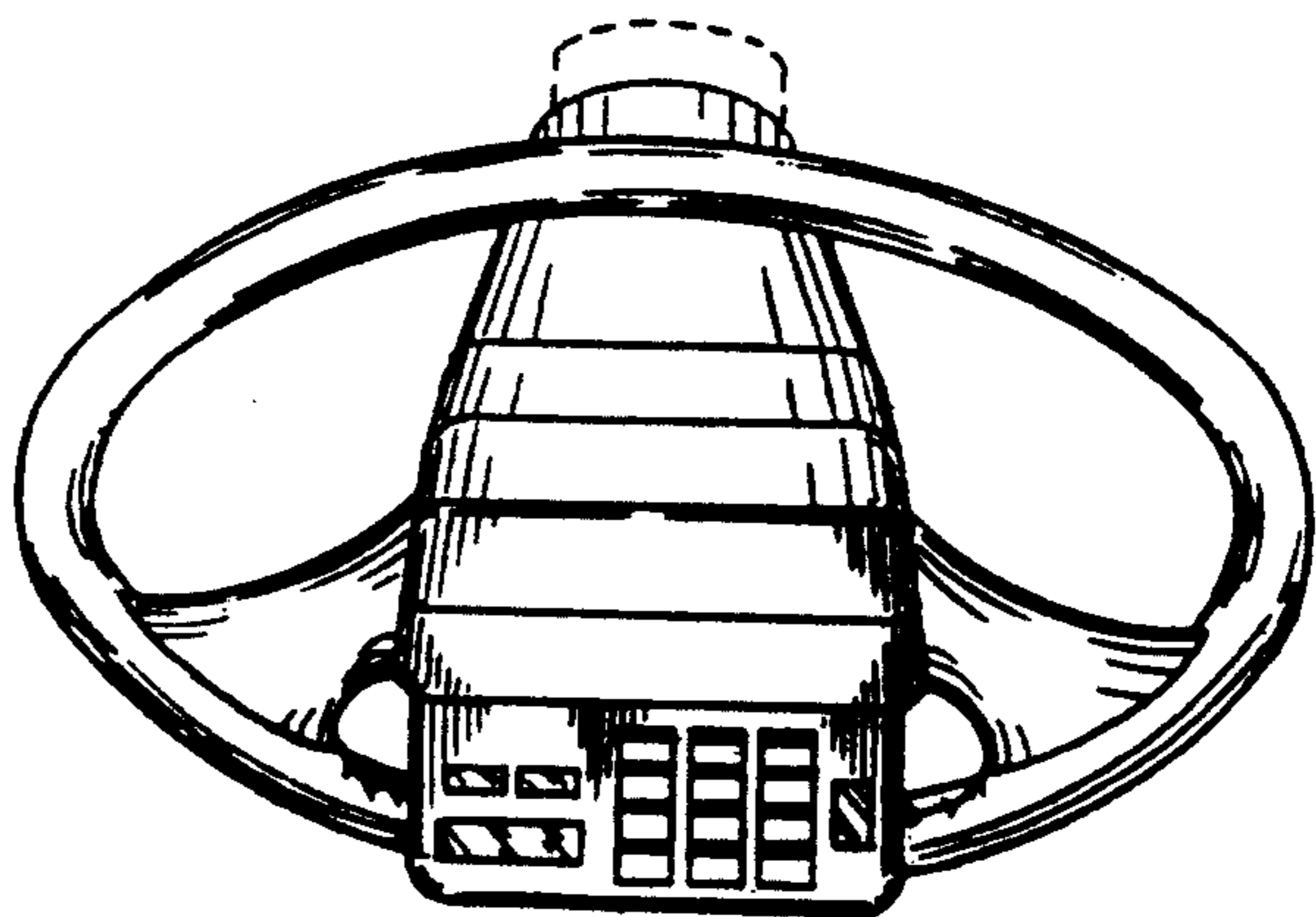

Fig. 6

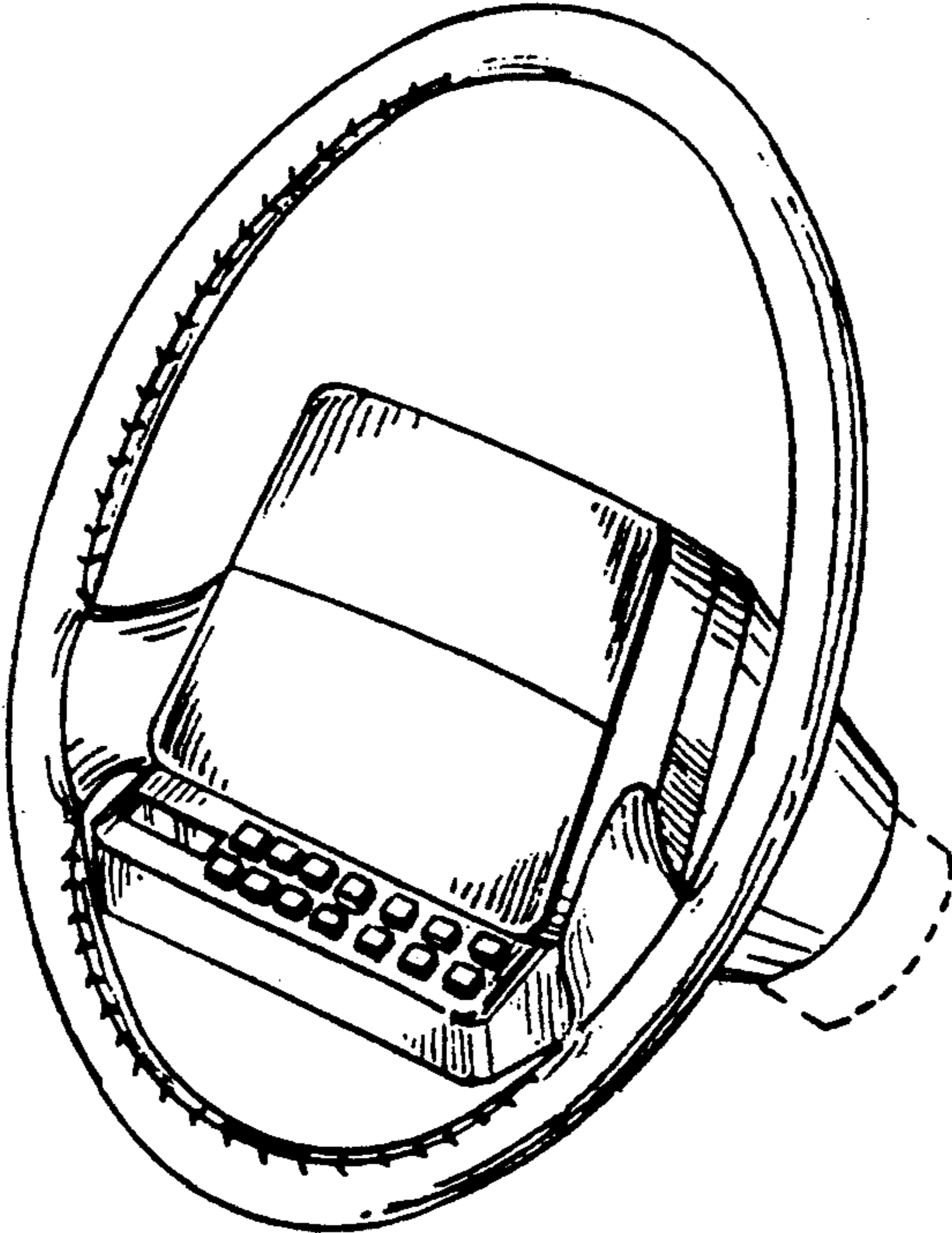

Fig. 7

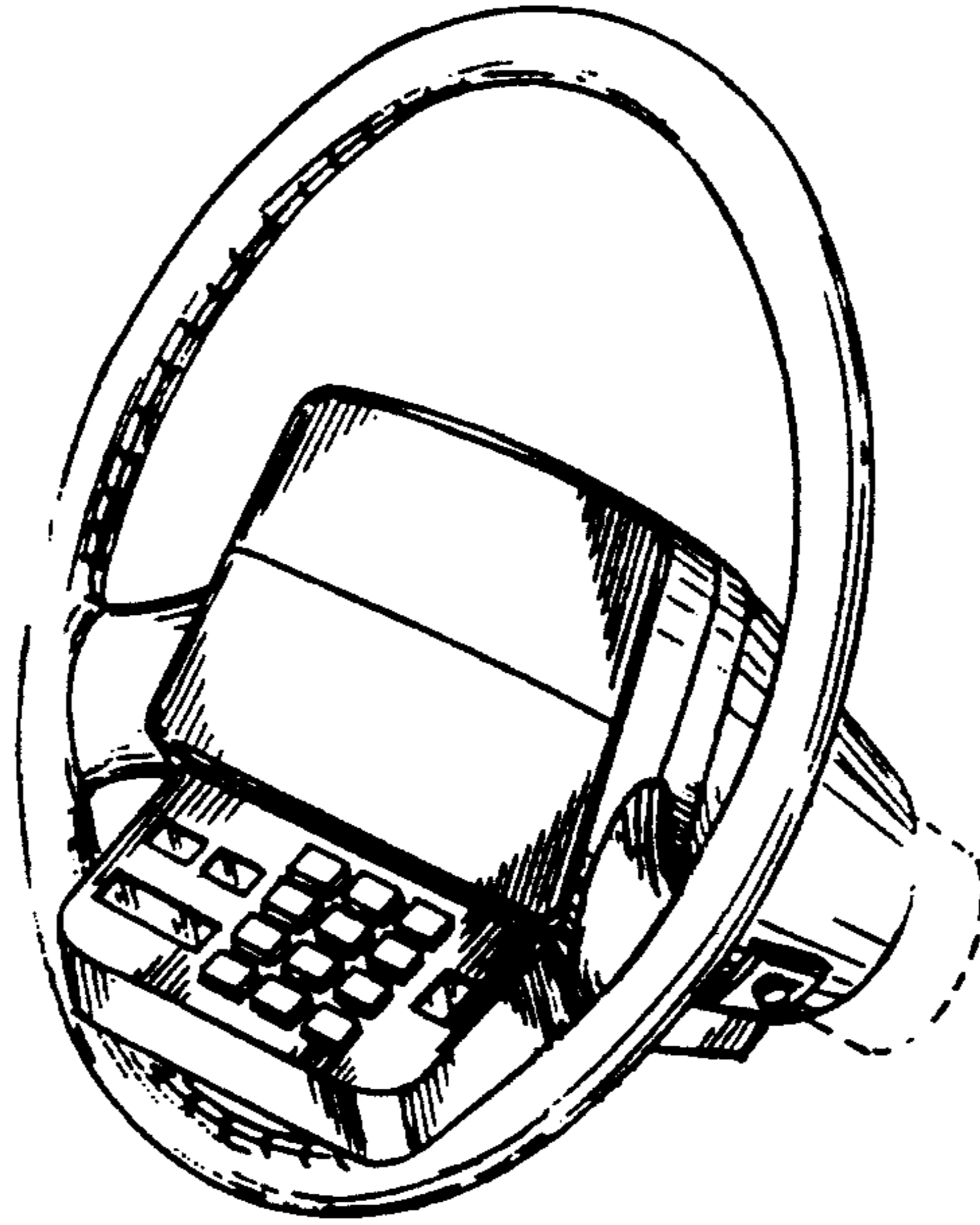

Fig. 8

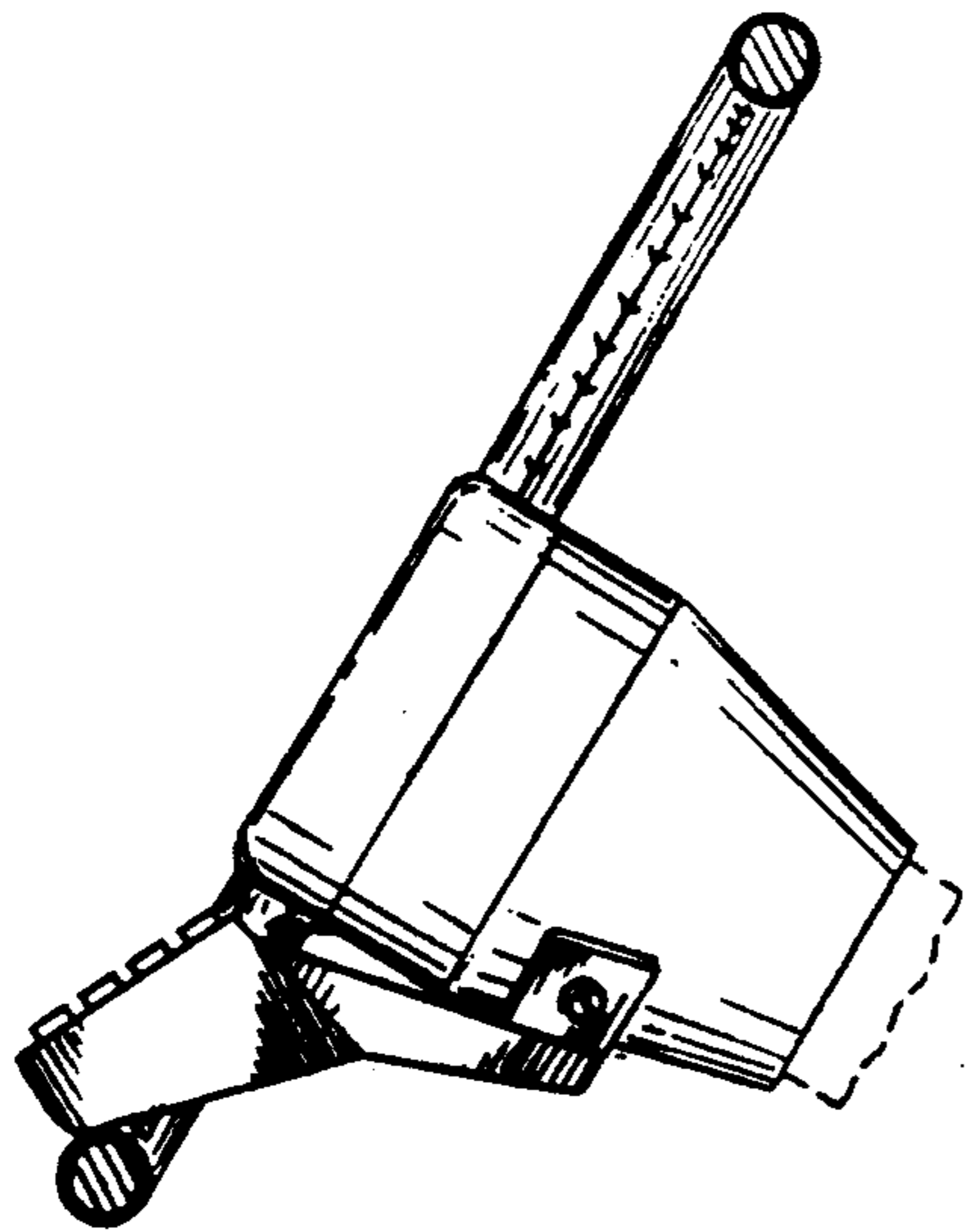

Fig. 9

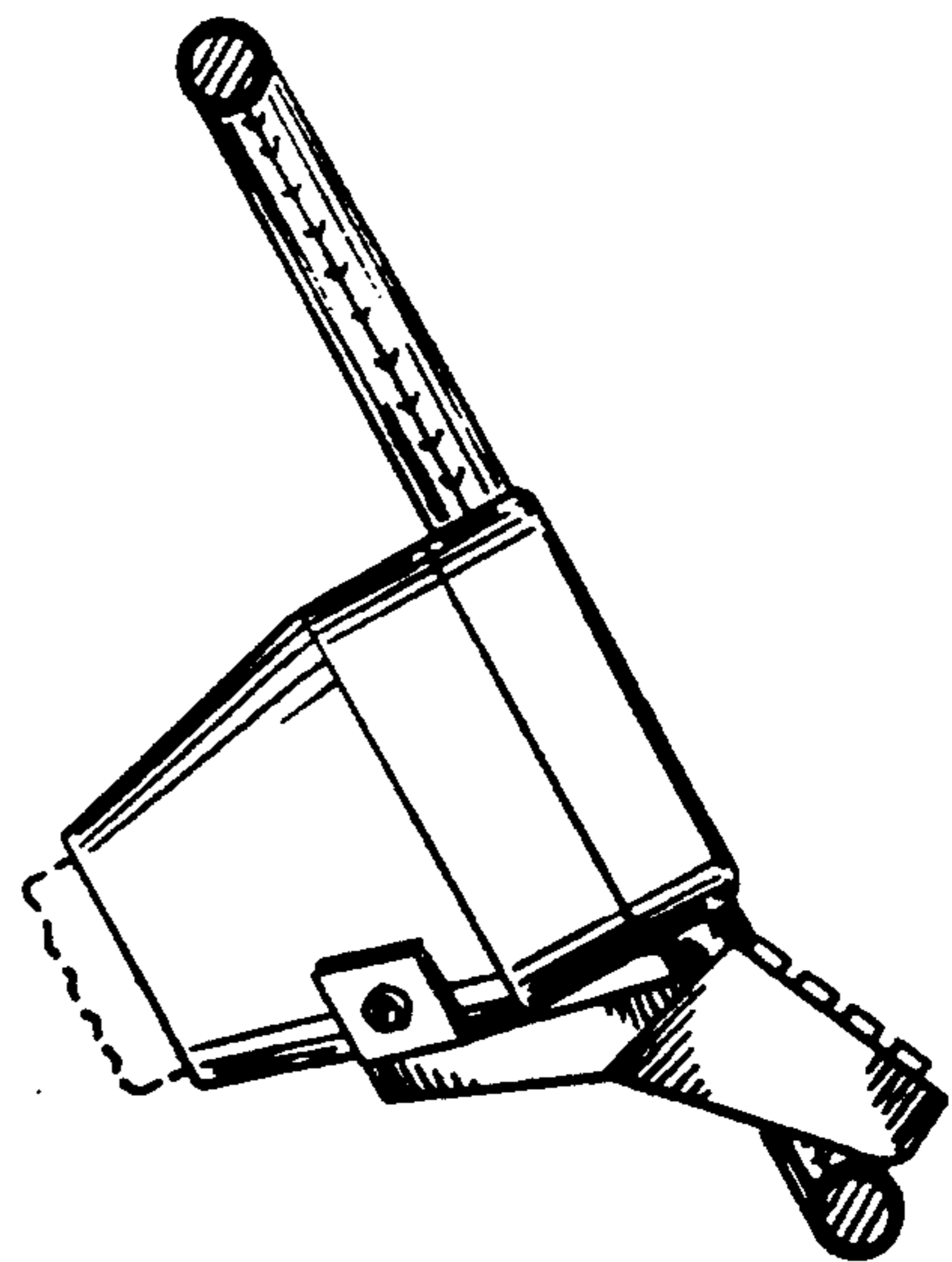

Fig. 10

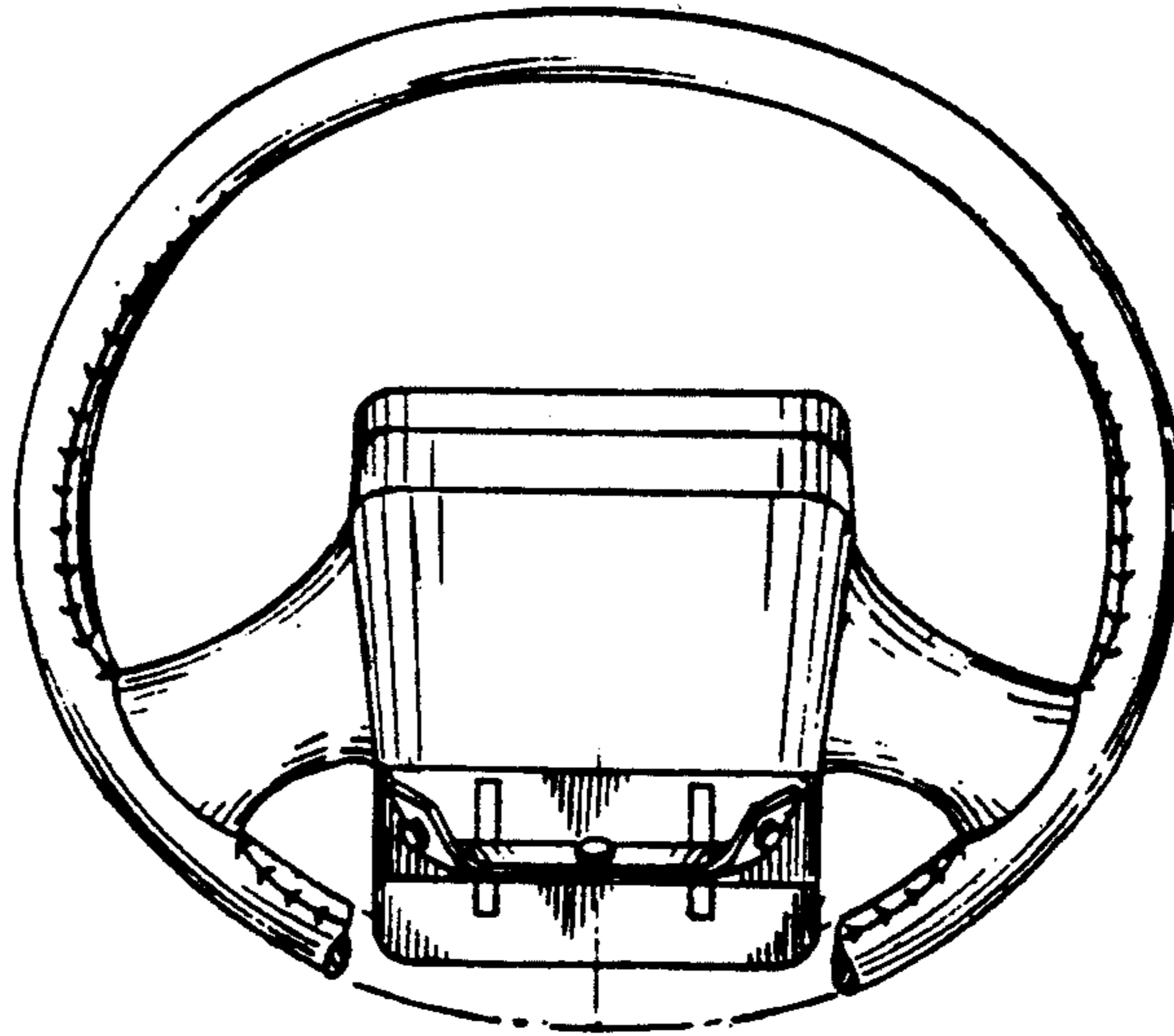

Fig. 11

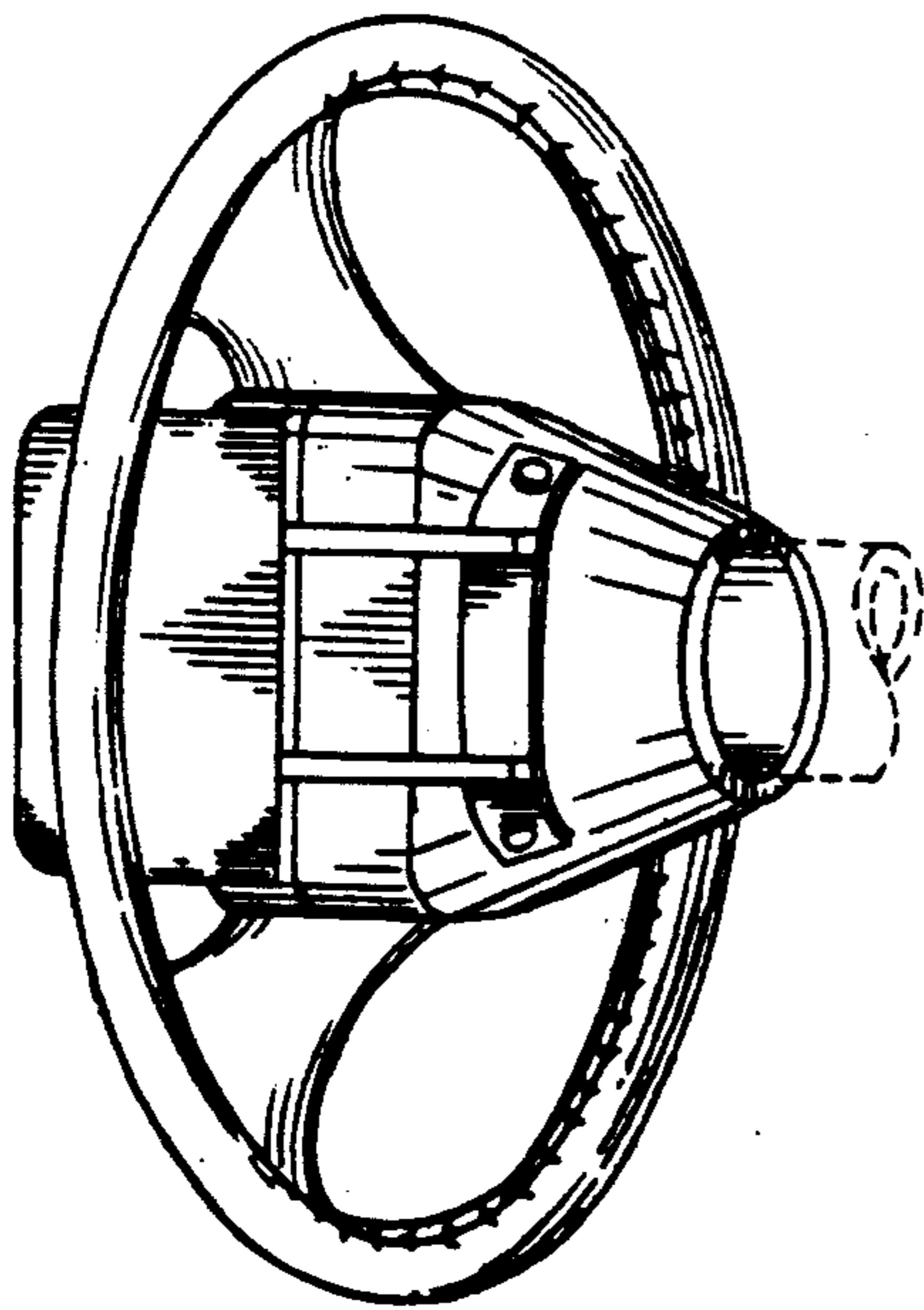

Fig. 12

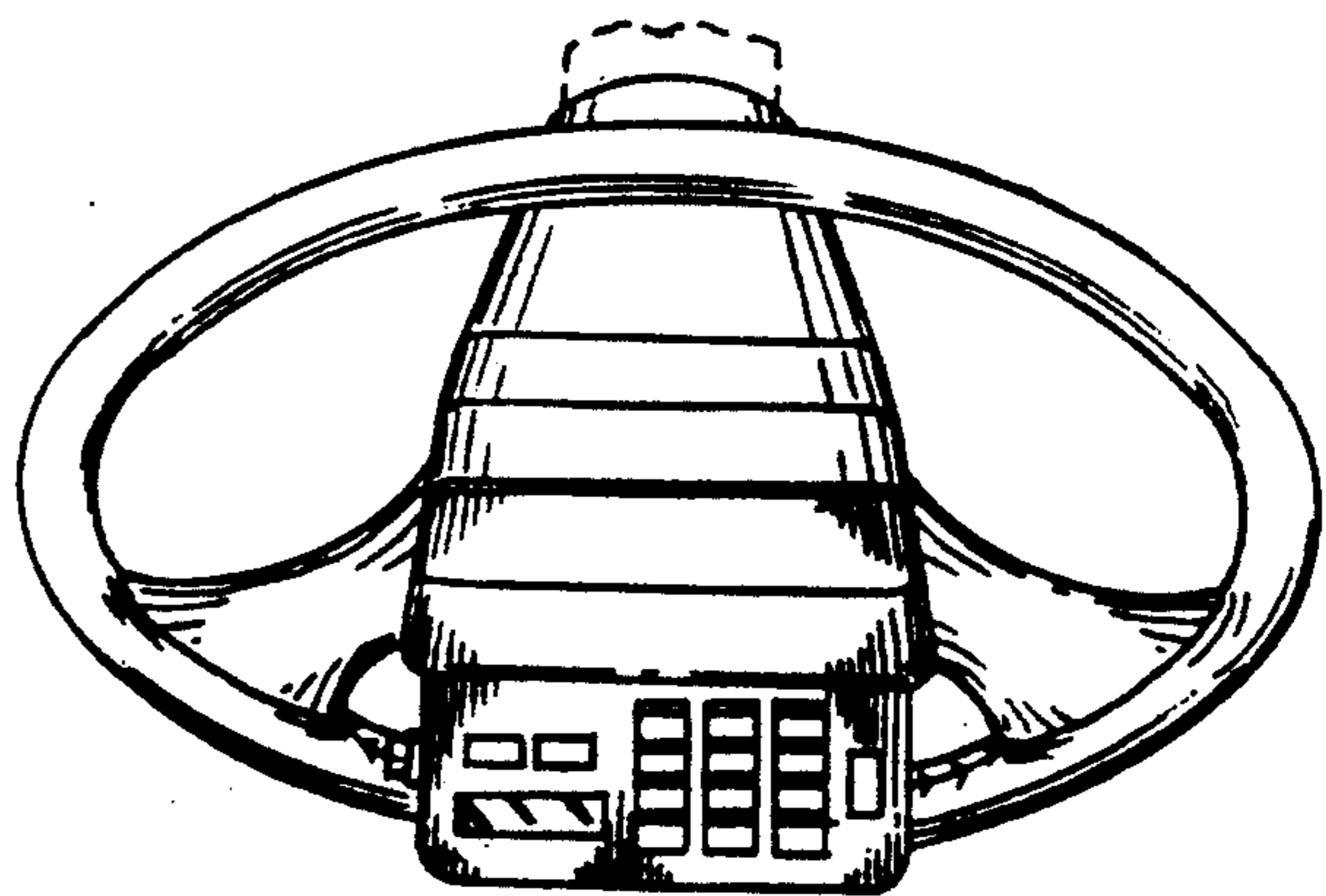

Fig. 13