



US00D345431S

United States Patent [19]

[11] Patent Number: Des. 345,431

Pogue

[45] Date of Patent: ** Mar. 22, 1994

[54] TRUCK BED RAIL LIGHT

[76] Inventor: Jimmy D. Pogue, Rte. 6, Box 94-A, Ada, Oklahoma City, Okla. 74820

[**] Term: 14 Years

[21] Appl. No.: 607

[22] Filed: Oct. 20, 1992

[52] U.S. Cl. D26/28

[58] Field of Search 362/61, 74, 80, 80.1, 362/82, 83, 83.3; D26/28-36; D10/114

[56] References Cited

U.S. PATENT DOCUMENTS

- D. 138,317 7/1944 Hallman D26/28
- D. 269,817 7/1983 Frazier D26/28 X

OTHER PUBLICATIONS

Dominion Auto Catalog 77, ©1977, p. 13, Compartment Lamp #1.

Dominion Auto Catalog 77, ©1977, p. 14, License Lamp #4.

Primary Examiner—Susan J. Lucas
Attorney, Agent, or Firm—Bill D. McCarthy

[57] CLAIM

The ornamental design for a truck bed rail light, as shown and described.

DESCRIPTION

FIG. 1 is a side elevational view of a truck bed rail light showing my new design with a portion of a pickup truck in broken lines for illustrative purposes only and forming no part of the claimed design;

FIG. 2 is a perspective view of the truck bed rail light on an enlarged scale;

FIG. 3 is a front elevational view thereof;

FIG. 4 is a rear elevational view thereof;

FIG. 5 is a side elevational view thereof;

FIG. 6 is a side elevational view thereof, opposite that shown in FIG. 5;

FIG. 7 is a top plan view thereof; and,

FIG. 8 is a bottom plan view thereof.

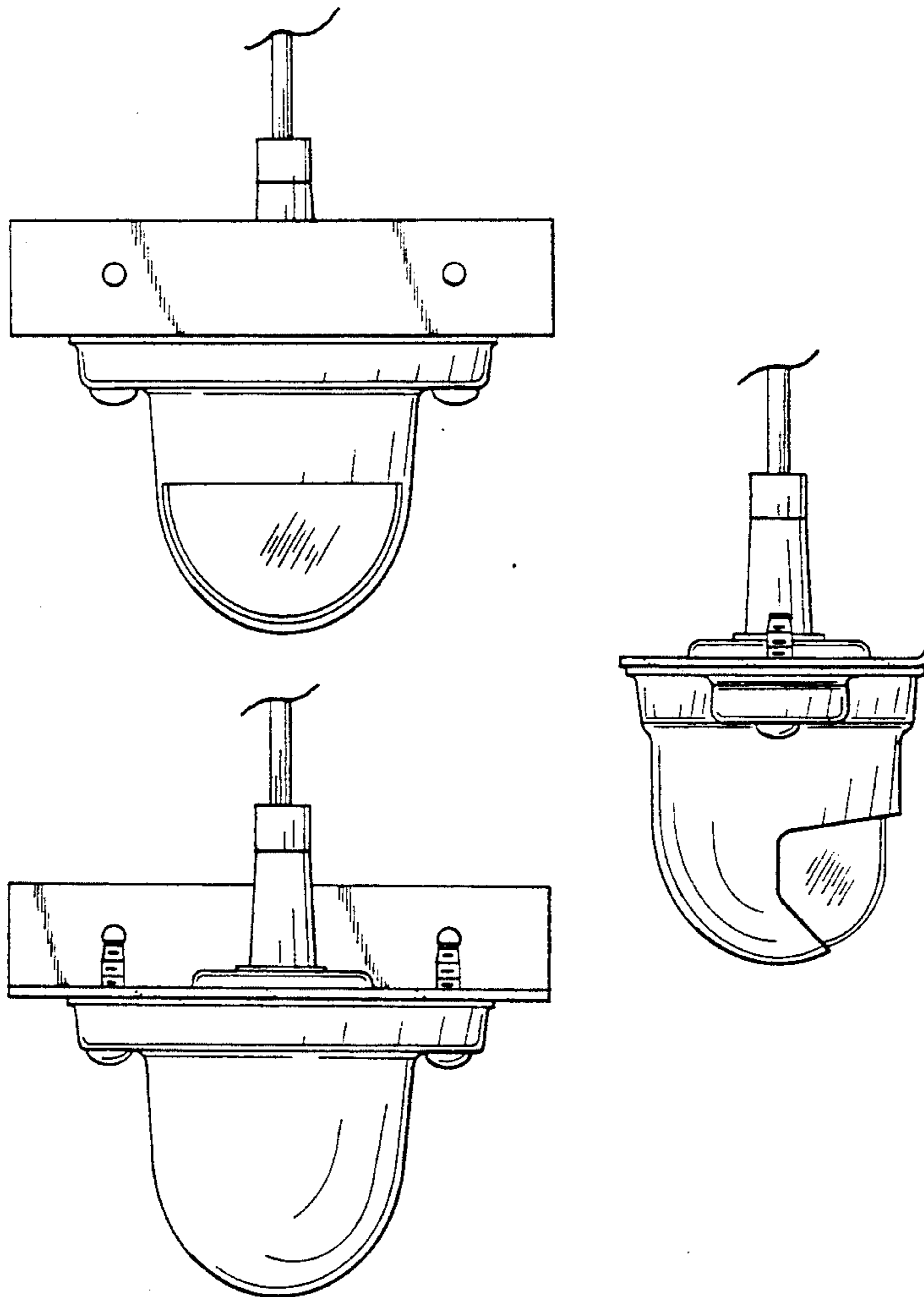

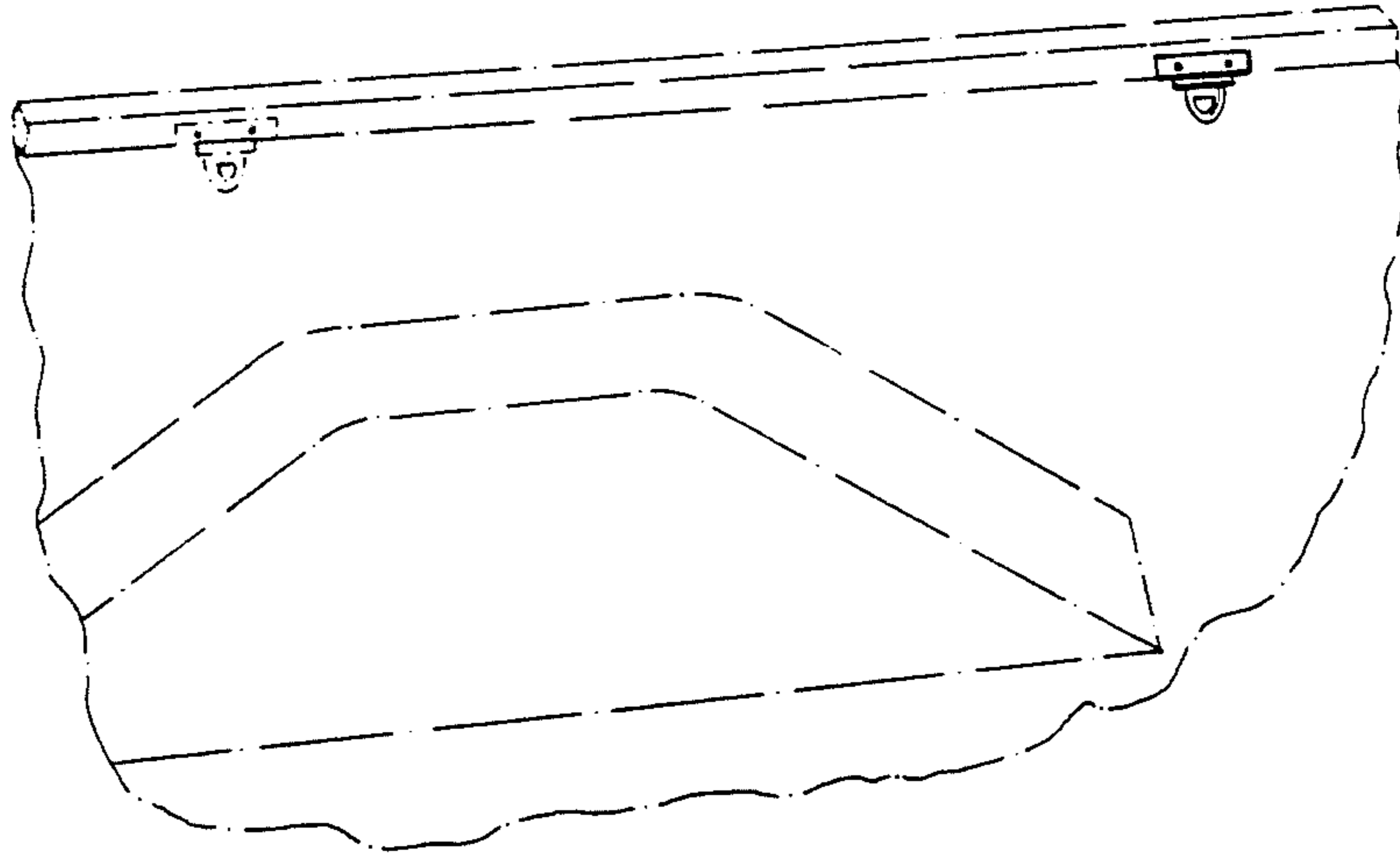

FIG. 1

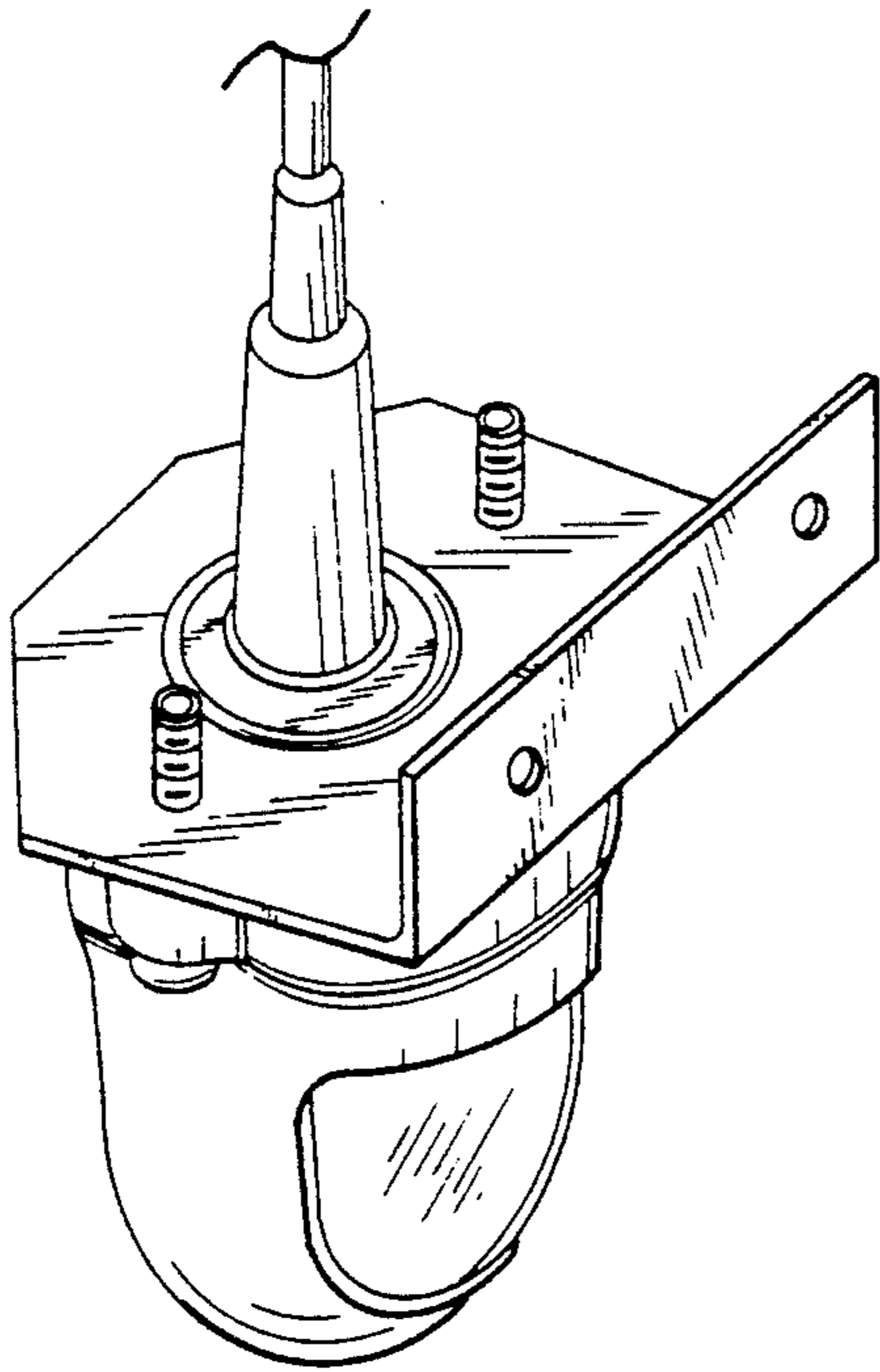

FIG. 2

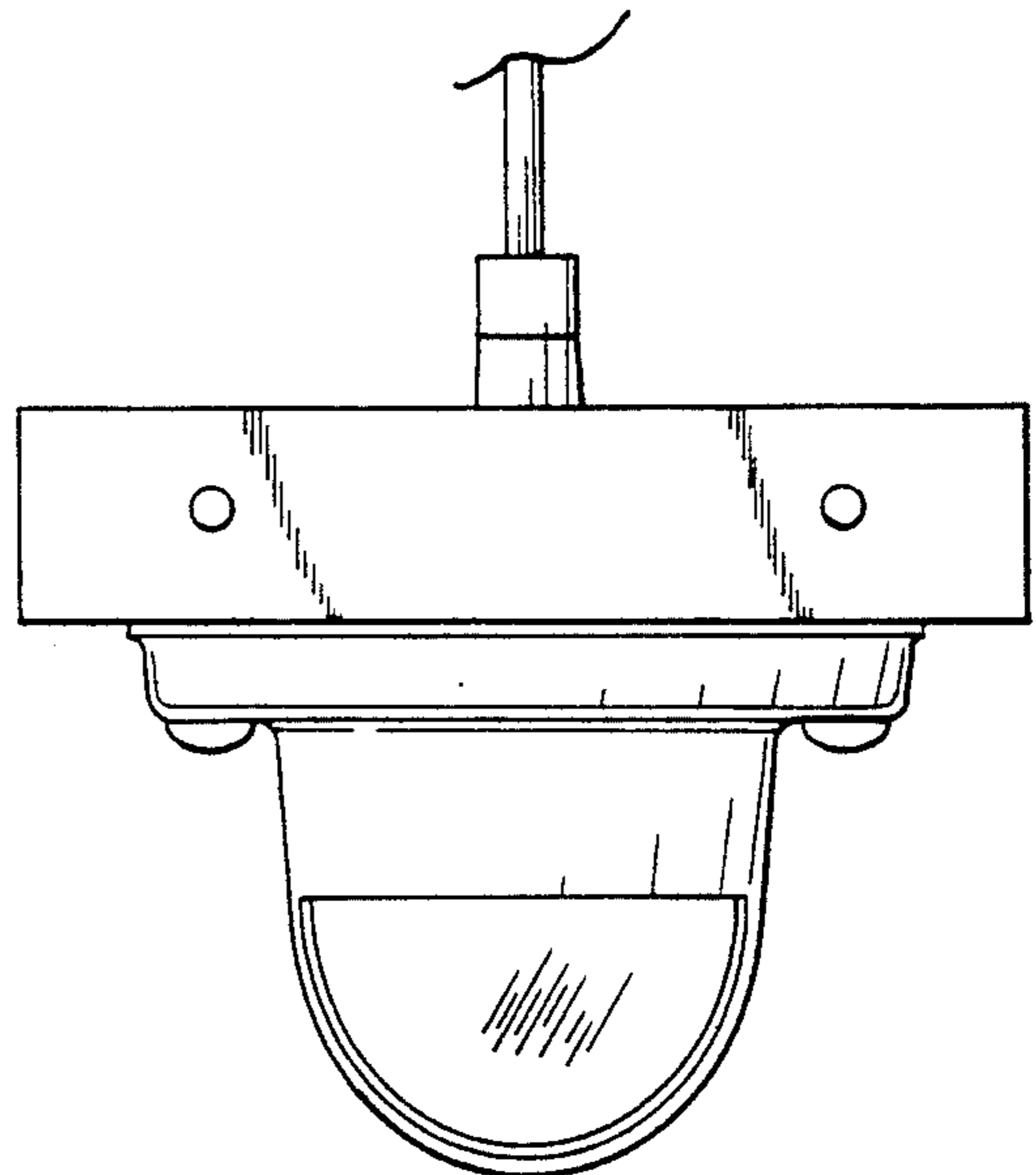

FIG. 3

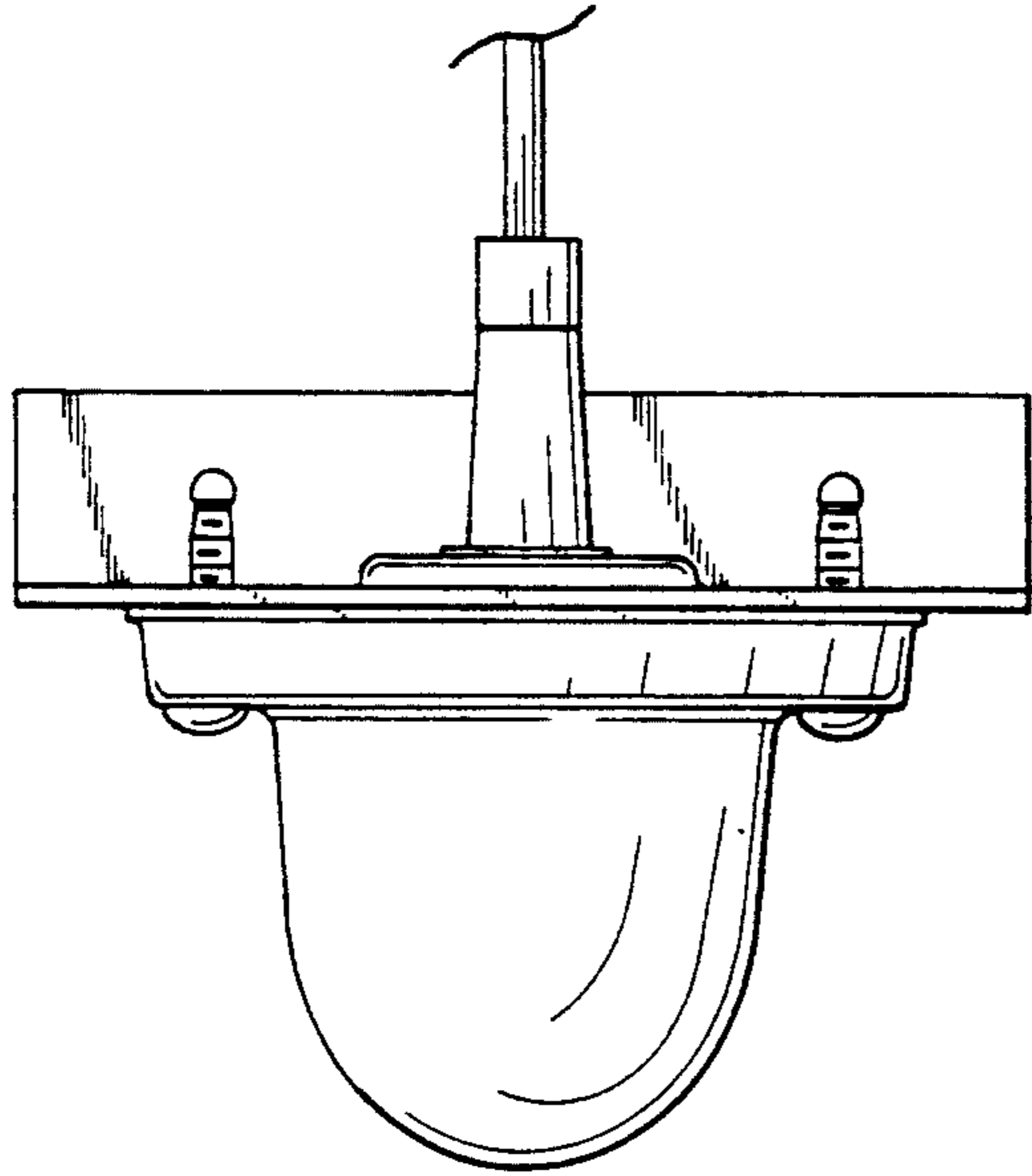

FIG. 4

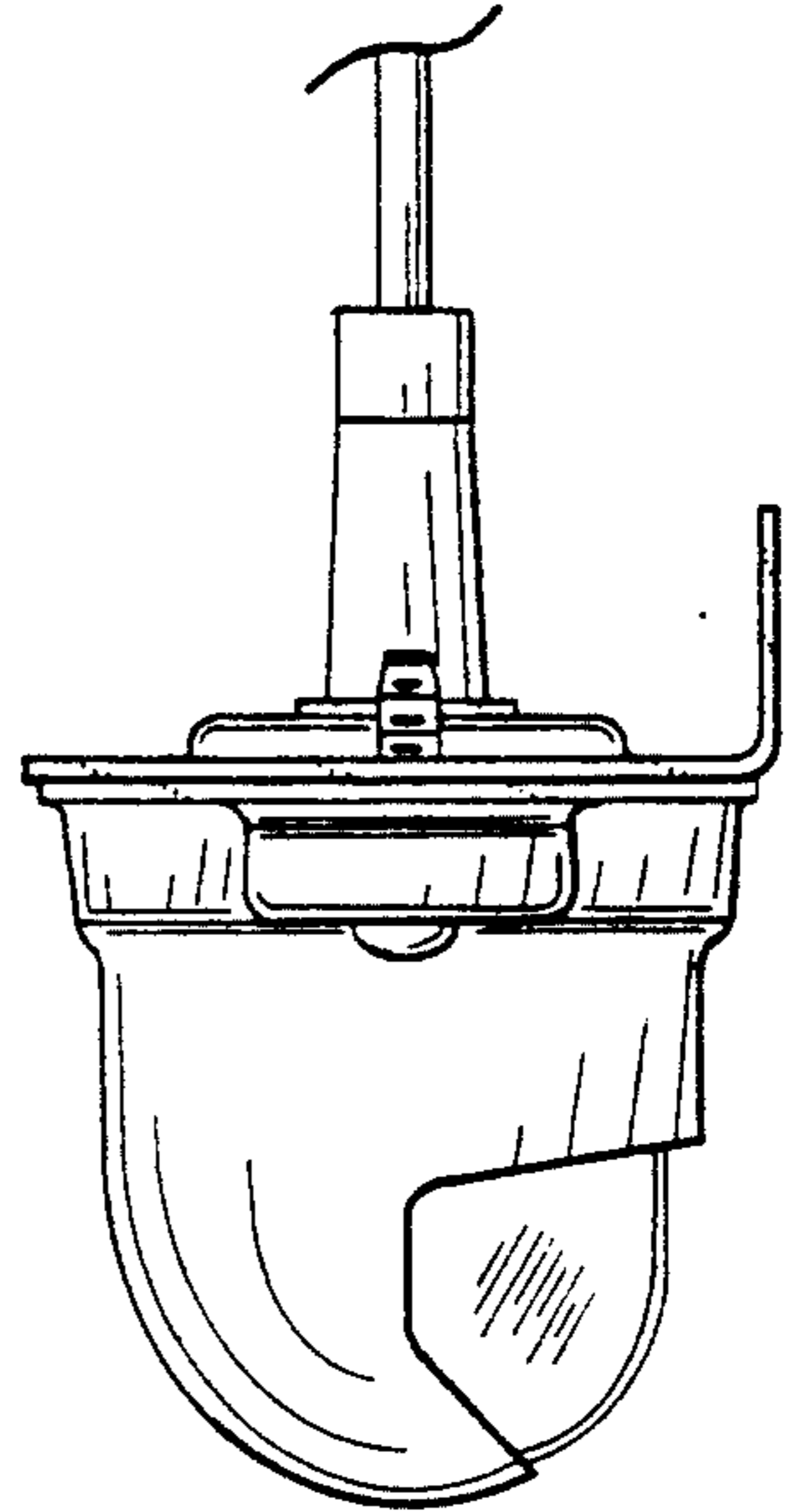

FIG. 5

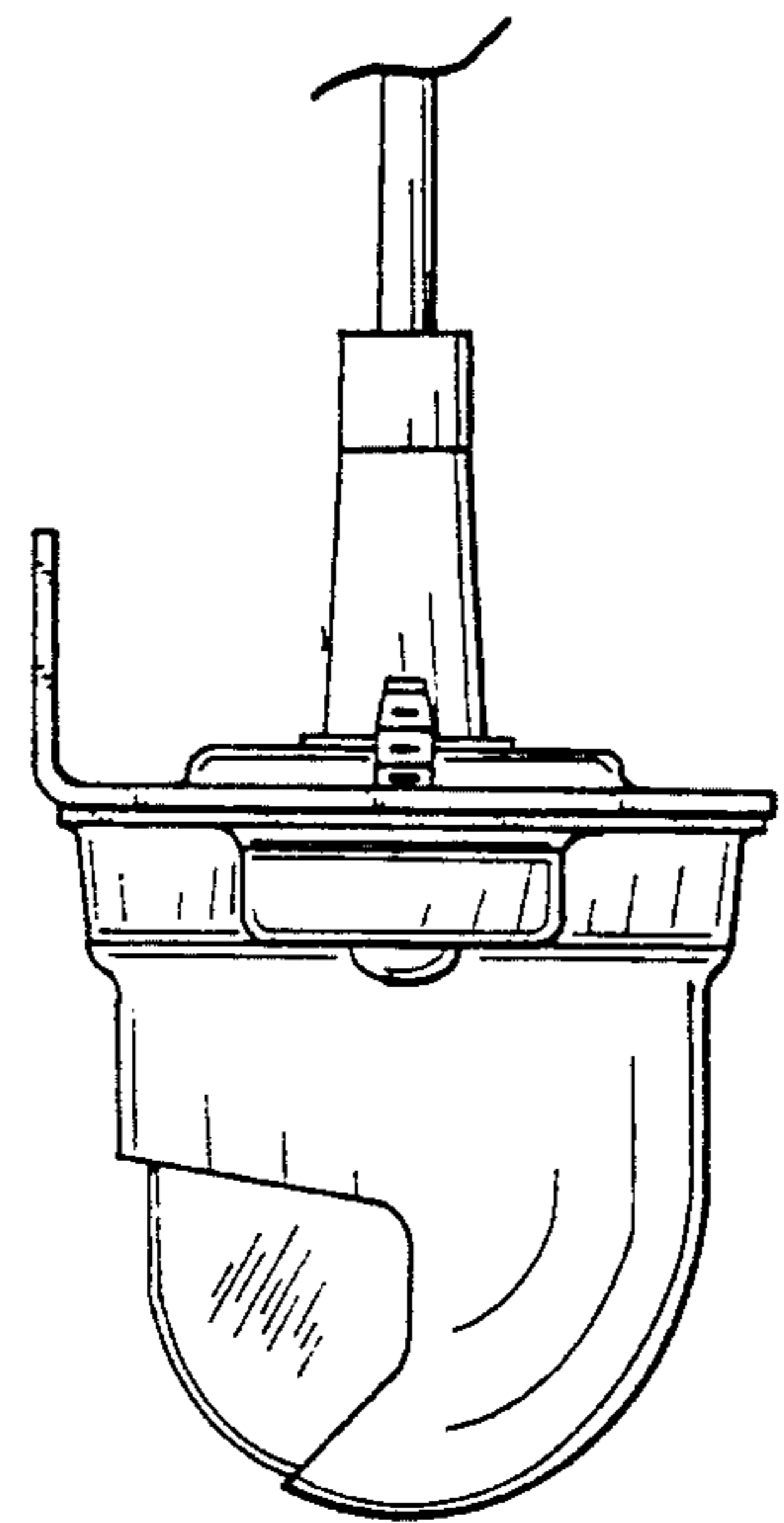

FIG. 6

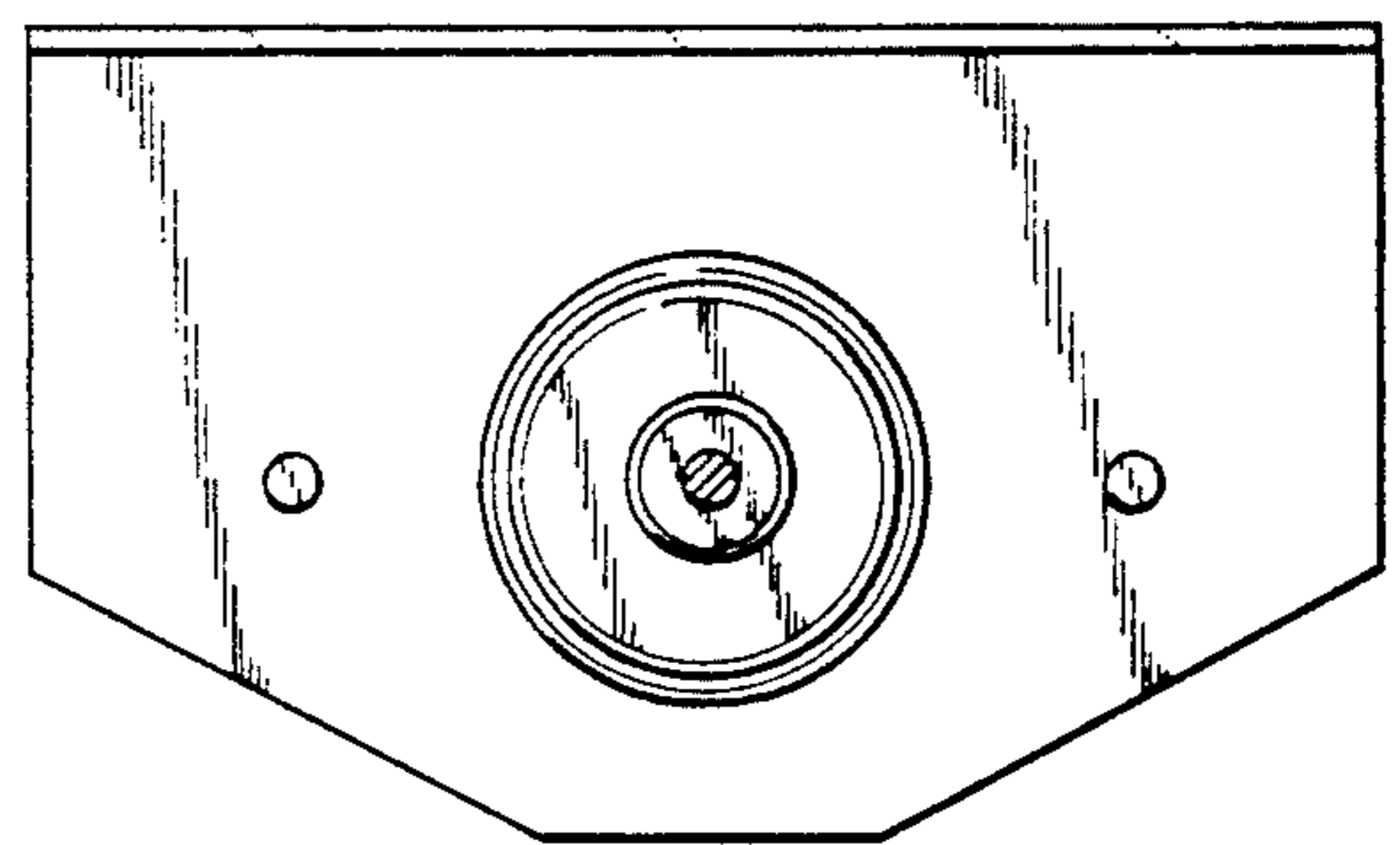

FIG. 7

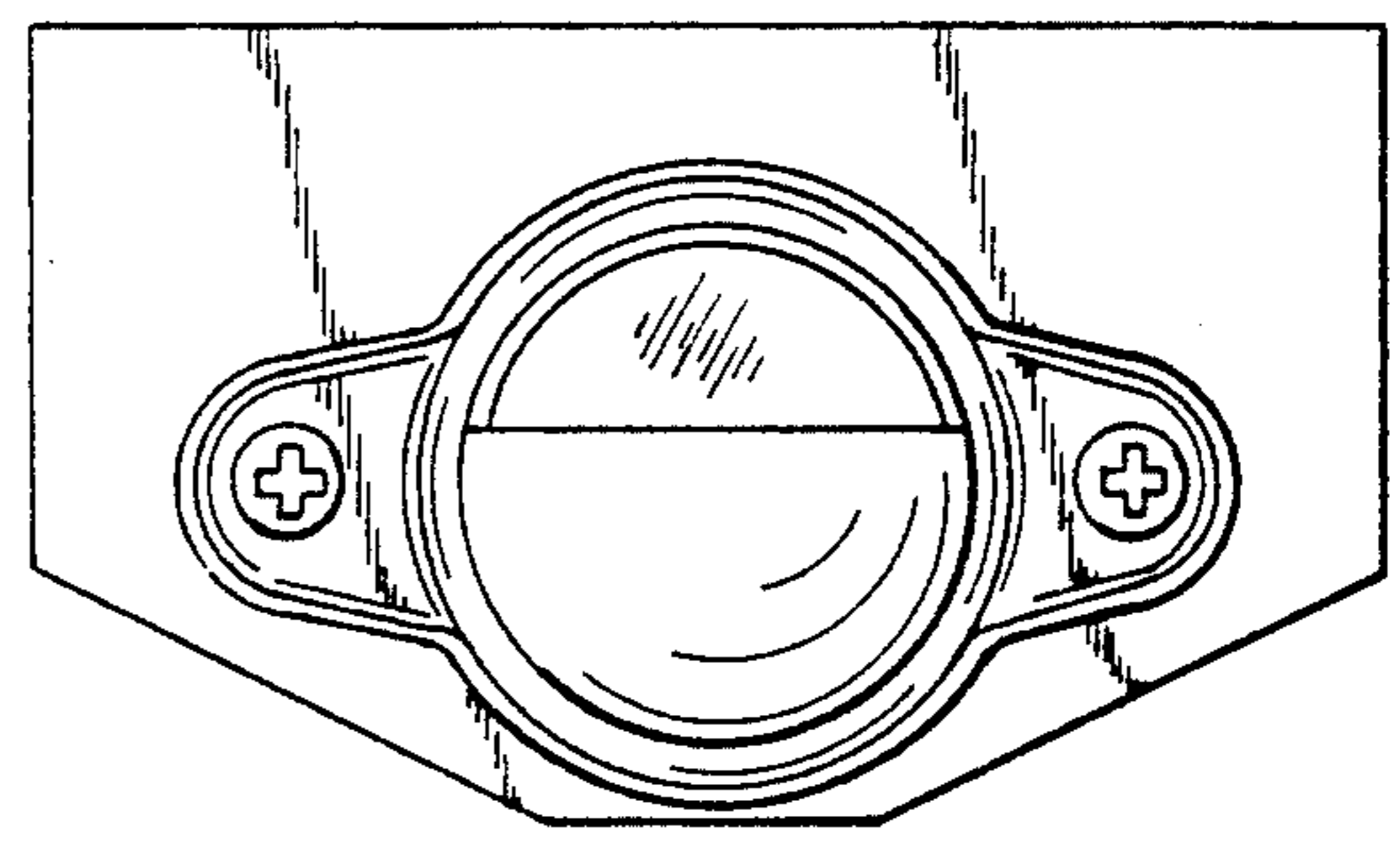

FIG. 8