



US00D345337S

United States Patent [19]

[11] Patent Number: **Des. 345,337**

Feller

[45] Date of Patent: **** Mar. 22, 1994**

[54] **SPARE TIRE CARRIER**

[75] Inventor: **Robert P. Feller, Milwaukee, Wis.**

[73] Assignee: **Fulton Performance Products, Inc., West Allis, Wis.**

[**] Term: **14 Years**

[21] Appl. No.: **929,802**

[22] Filed: **Aug. 13, 1992**

[52] U.S. Cl. **D12/202**

[58] Field of Search 224/42.06, 42.42, 42.45 R;
D12/202

FOREIGN PATENT DOCUMENTS

0622585 2/1927 France 224/42.12

Primary Examiner—Wallace R. Burke
Assistant Examiner—Melody Brown
Attorney, Agent, or Firm—Edgar A. Zarins; Malcolm L. Sutherland

[57] **CLAIM**

The ornamental design for a spare tire carrier, as shown and described.

DESCRIPTION

FIG. 1 is a perspective view of a spare tire carrier showing my new design the broken lines are for illustrative purposes only and forms no part of the claimed design; FIG. 2 is a front elevational view thereof; FIG. 3 is a rear elevational view thereof; FIG. 4 is a left side view thereof; FIG. 5 is a right side view thereof; FIG. 6 is a top plan view thereof; and, FIG. 7 is a bottom plan view thereof.

[56] **References Cited**

U.S. PATENT DOCUMENTS

D. 287,959	1/1987	Hooper, Jr.	D12/202
D. 289,030	3/1987	Bowman	D12/202
4,392,597	7/1983	Traugh	224/42.13
4,632,288	12/1986	Bullock	224/42.12
4,679,717	7/1987	Hansen	224/42.12
5,228,608	7/1993	Stout, III	D12/202

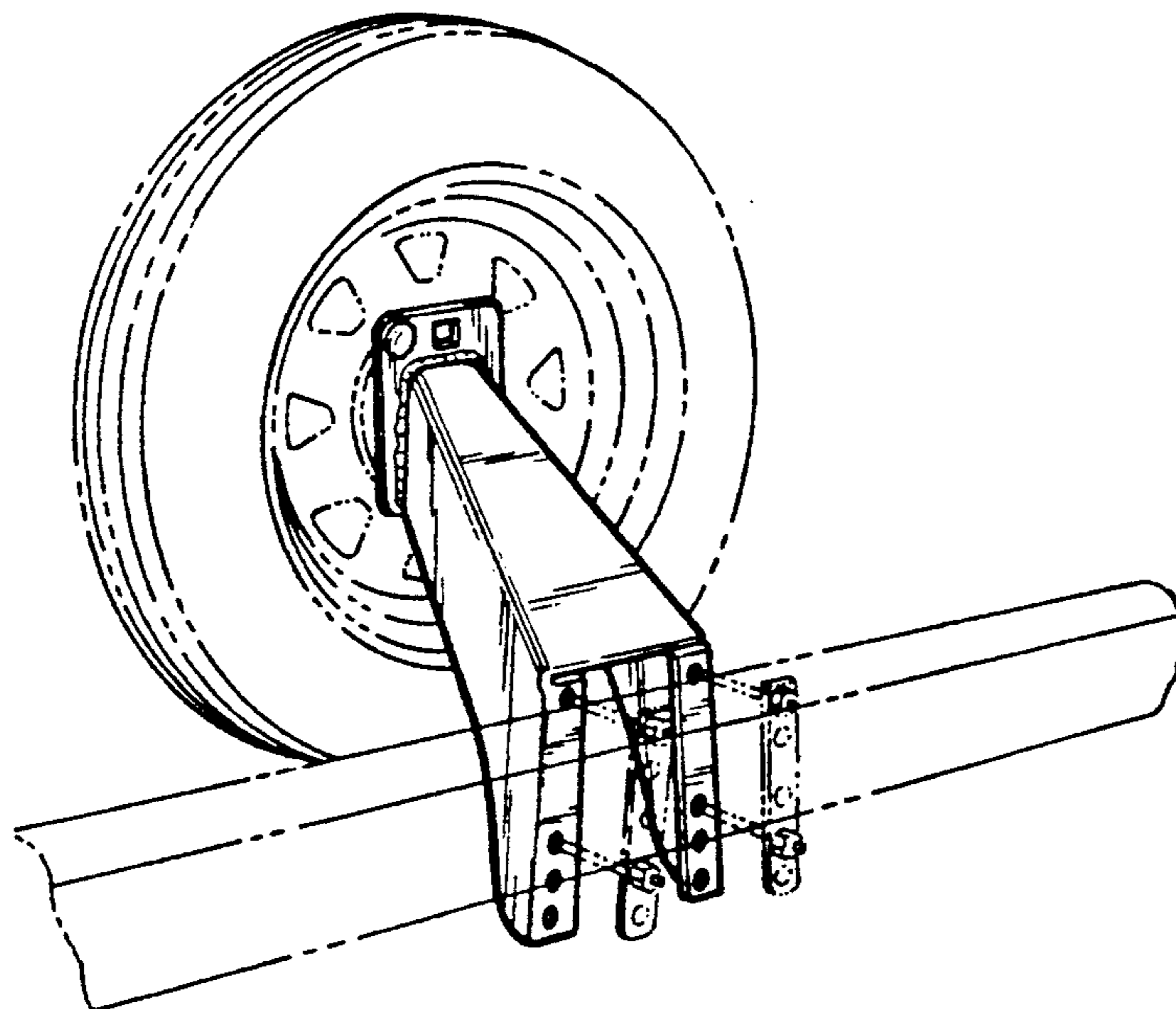

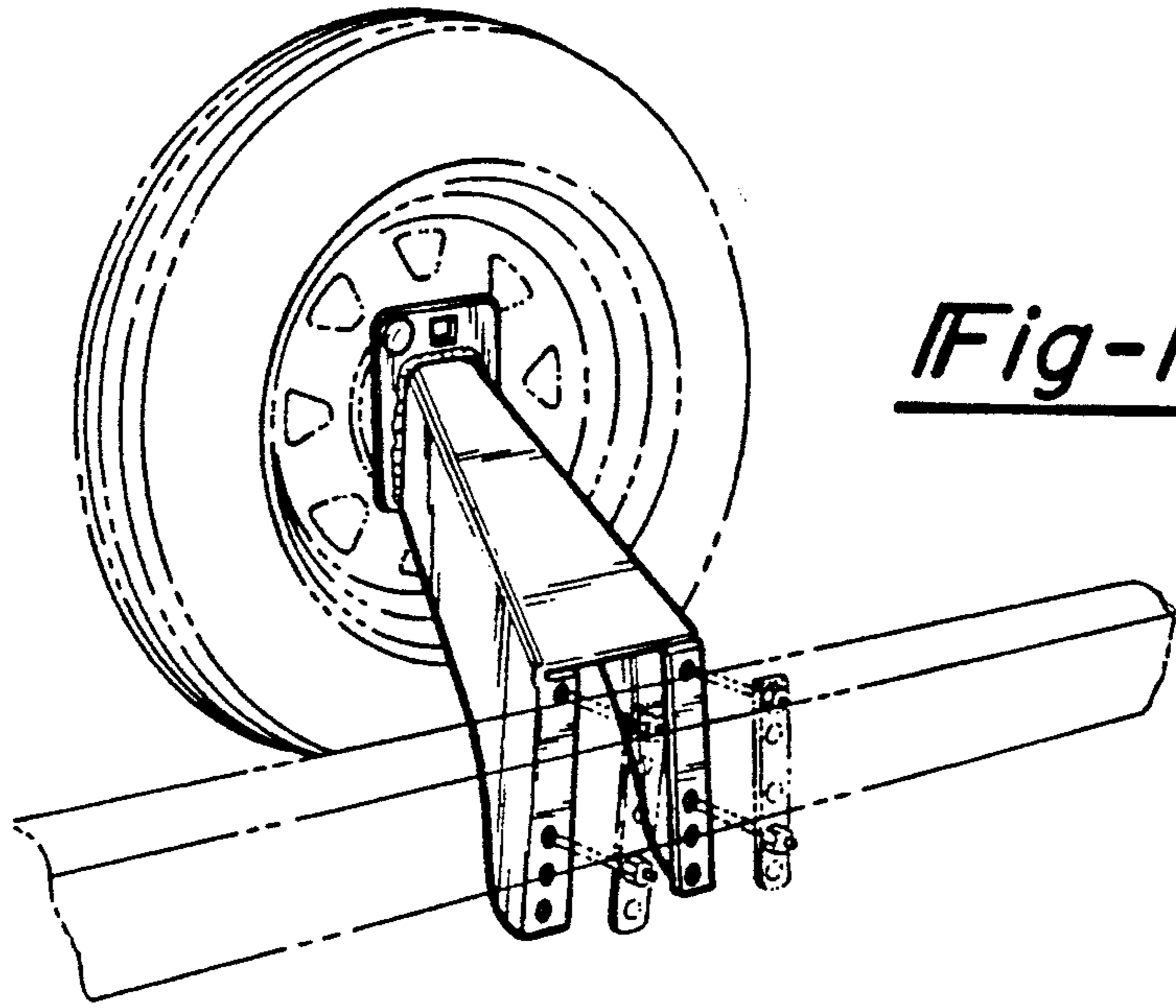

Fig-1

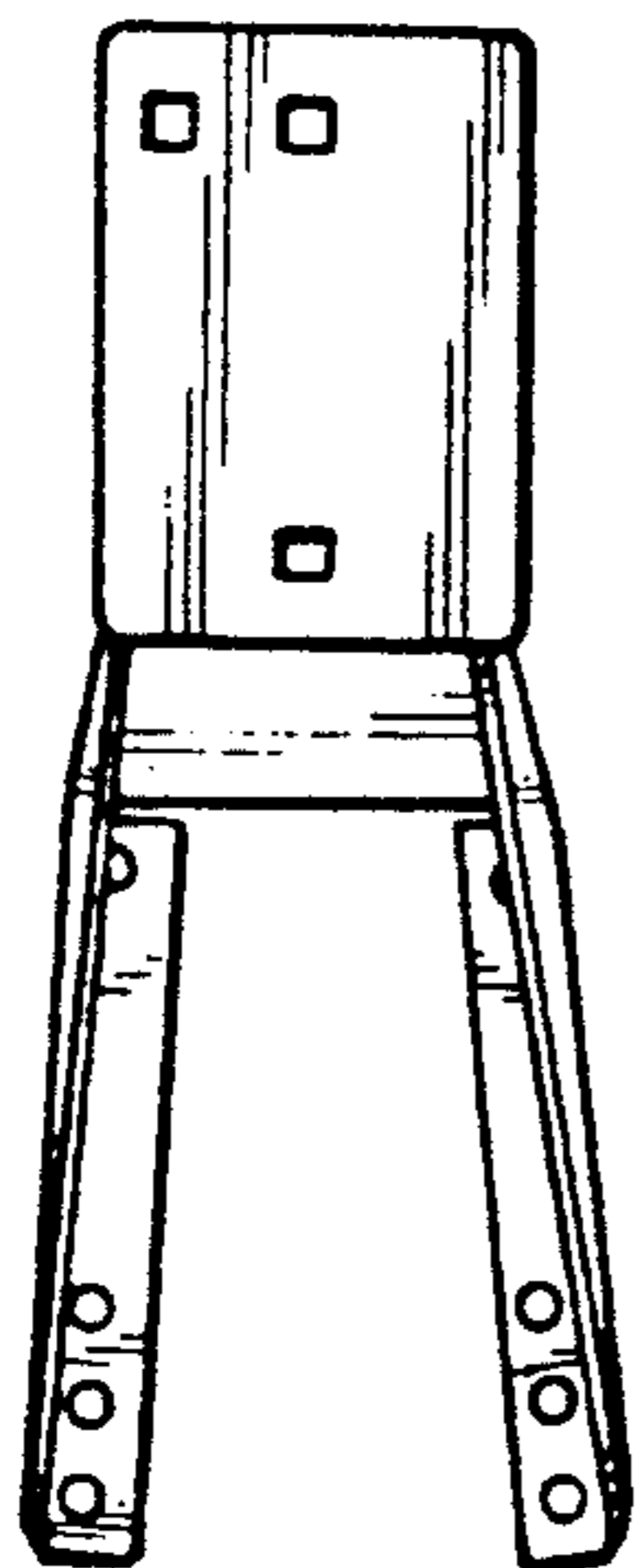

Fig-2

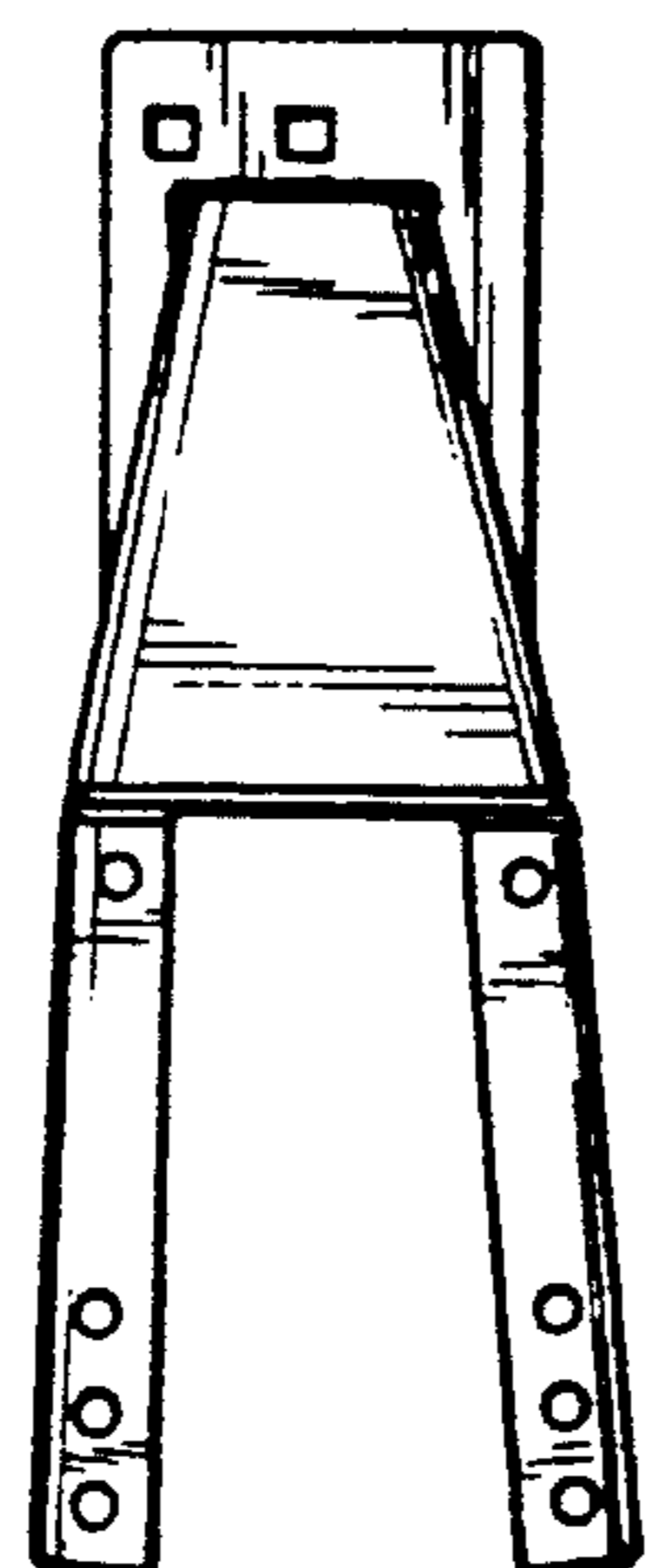

Fig-3

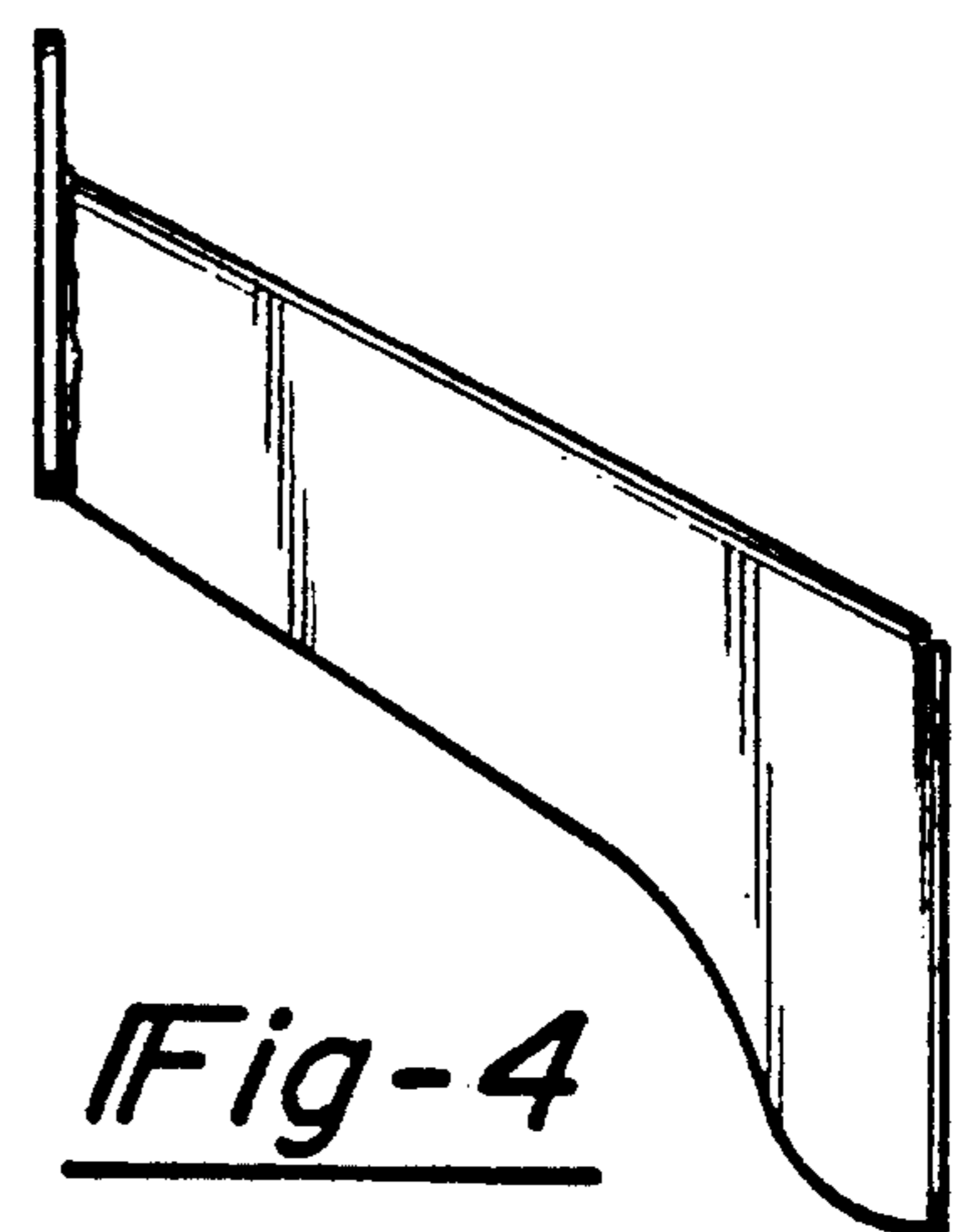

Fig-4

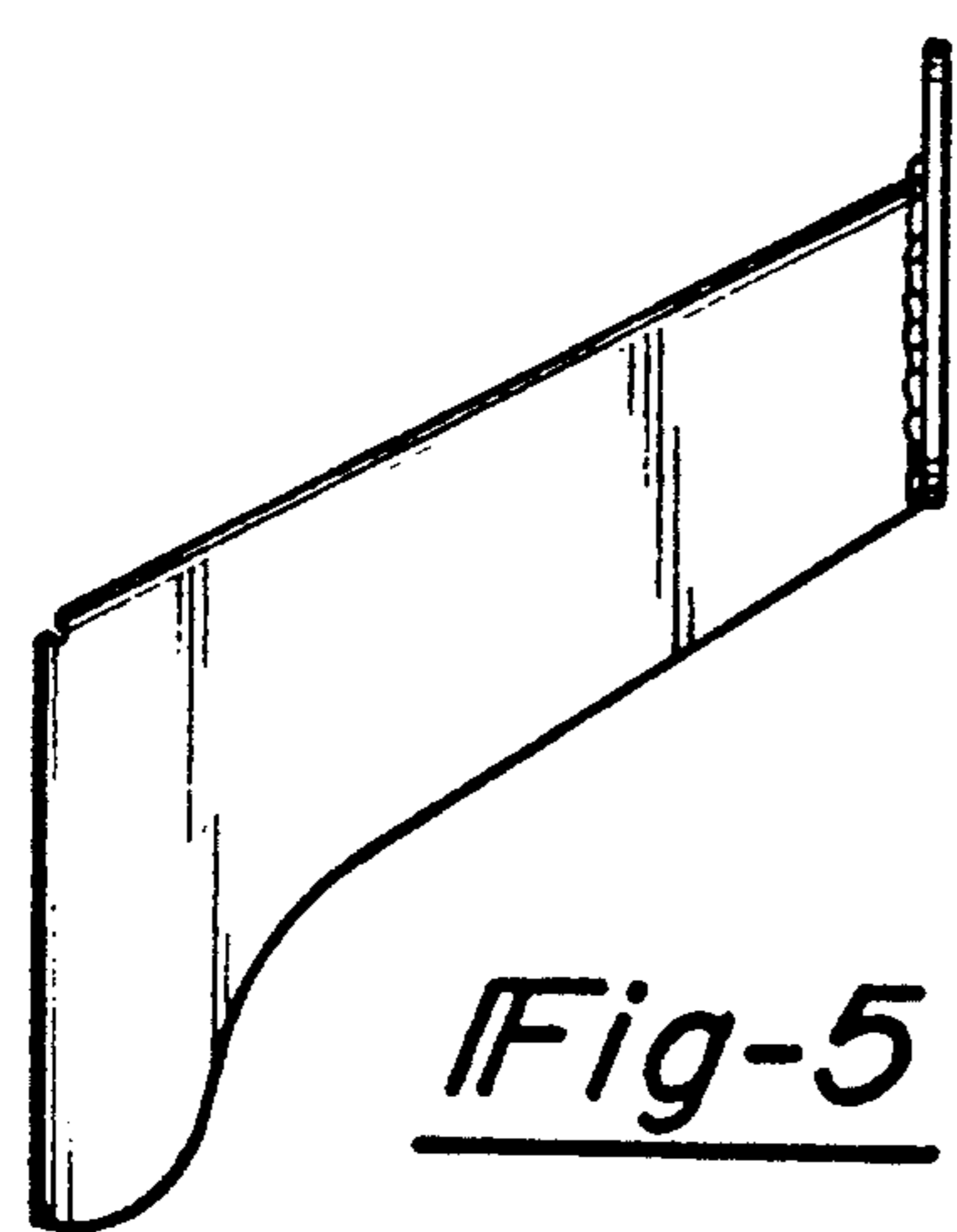

Fig-5

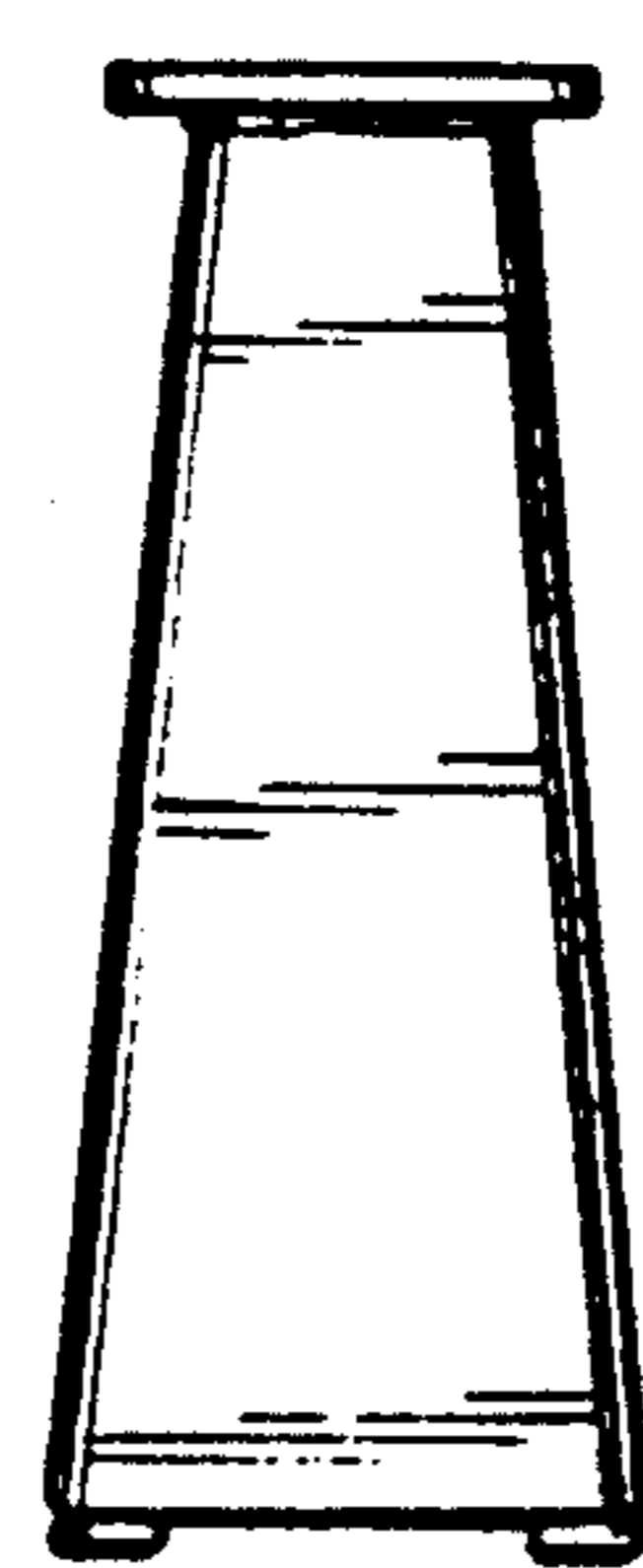

Fig-6

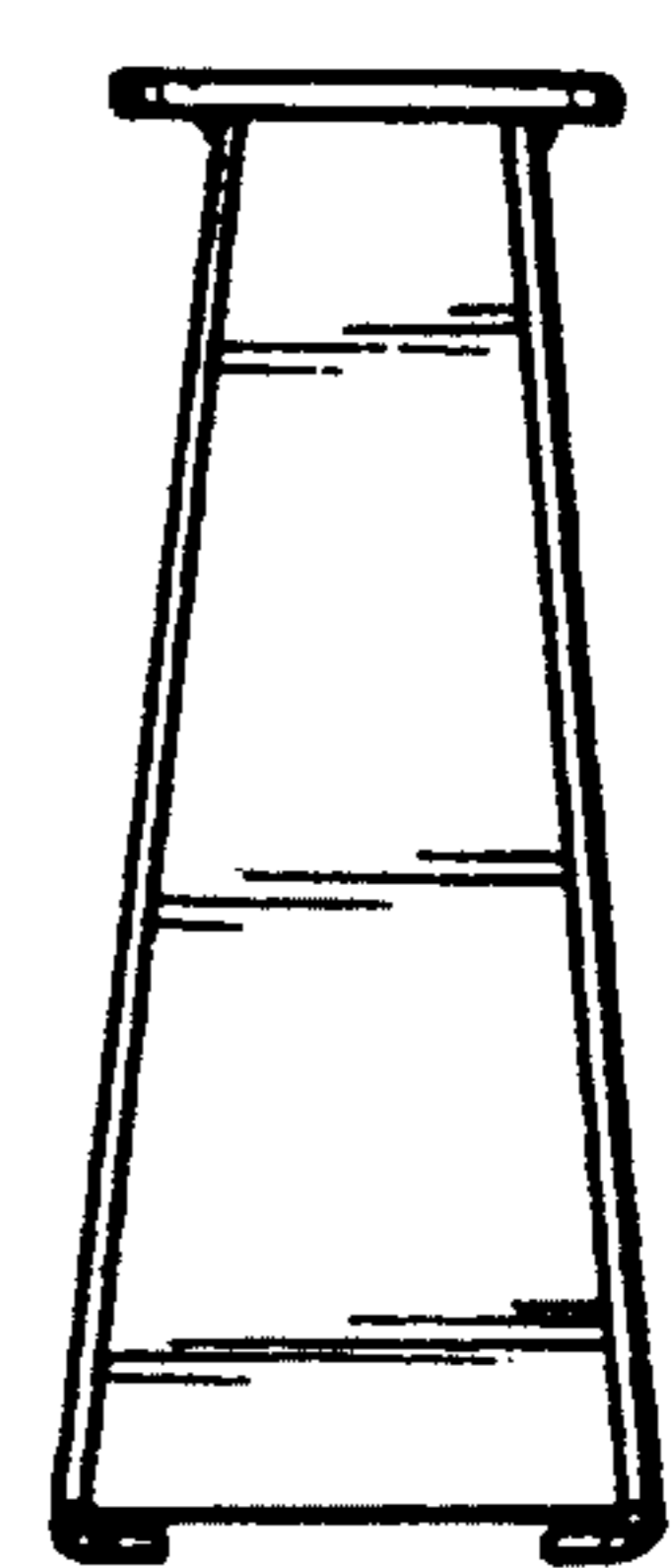

Fig-7