



US00D345332S

# United States Patent [19]

[11] Patent Number: **Des. 345,332**

Roman

[45] Date of Patent: **\*\* Mar. 22, 1994**

- [54] **AUTOMOBILE FENDER SKIRT**
- [75] Inventor: **Jerry Roman**, Avon Lake, Ohio
- [73] Assignee: **Roman Chariot, Inc.**, Cleveland, Ohio
- [\*\*] Term: **14 Years**
- [21] Appl. No.: **46**
- [22] Filed: **Oct. 1, 1992**
- [52] U.S. Cl. .... **D12/184**
- [58] Field of Search ..... 280/152.1, 848, 849, 280/851; D12/184, 190

*Primary Examiner*—Wallace R. Burke  
*Assistant Examiner*—Melody Brown  
*Attorney, Agent, or Firm*—Fay, Sharpe, Beall, Fagan, Minnich & McKee

### [57] CLAIM

The ornamental design for an automobile fender skirt, as shown and described.

### DESCRIPTION

FIG. 1 is a front elevational view of an automobile fender skirt showing my new design;  
 FIG. 2 is a side elevational view thereof;  
 FIG. 3 is a side elevational view thereof;  
 FIG. 4 is an opposite side elevational view thereof;  
 FIG. 5 is a rear elevational view thereof; and,  
 FIG. 6 is a bottom plan view thereof.

The broken lines shown in FIGS. 1, 2, 3, 5 and 6 showing the associate automobile and the flange of the automobile fender skirt is for illustrative purposes only and forms no part of the claimed design.

- [56] **References Cited**
- U.S. PATENT DOCUMENTS**
- D. 299,019 12/1988 McKinnon ..... D12/184
- D. 321,160 10/1991 Kingsley ..... D12/184
- D. 321,161 10/1991 Ueno ..... D12/184
- 2,832,609 4/1956 Buckenhyer ..... 280/848

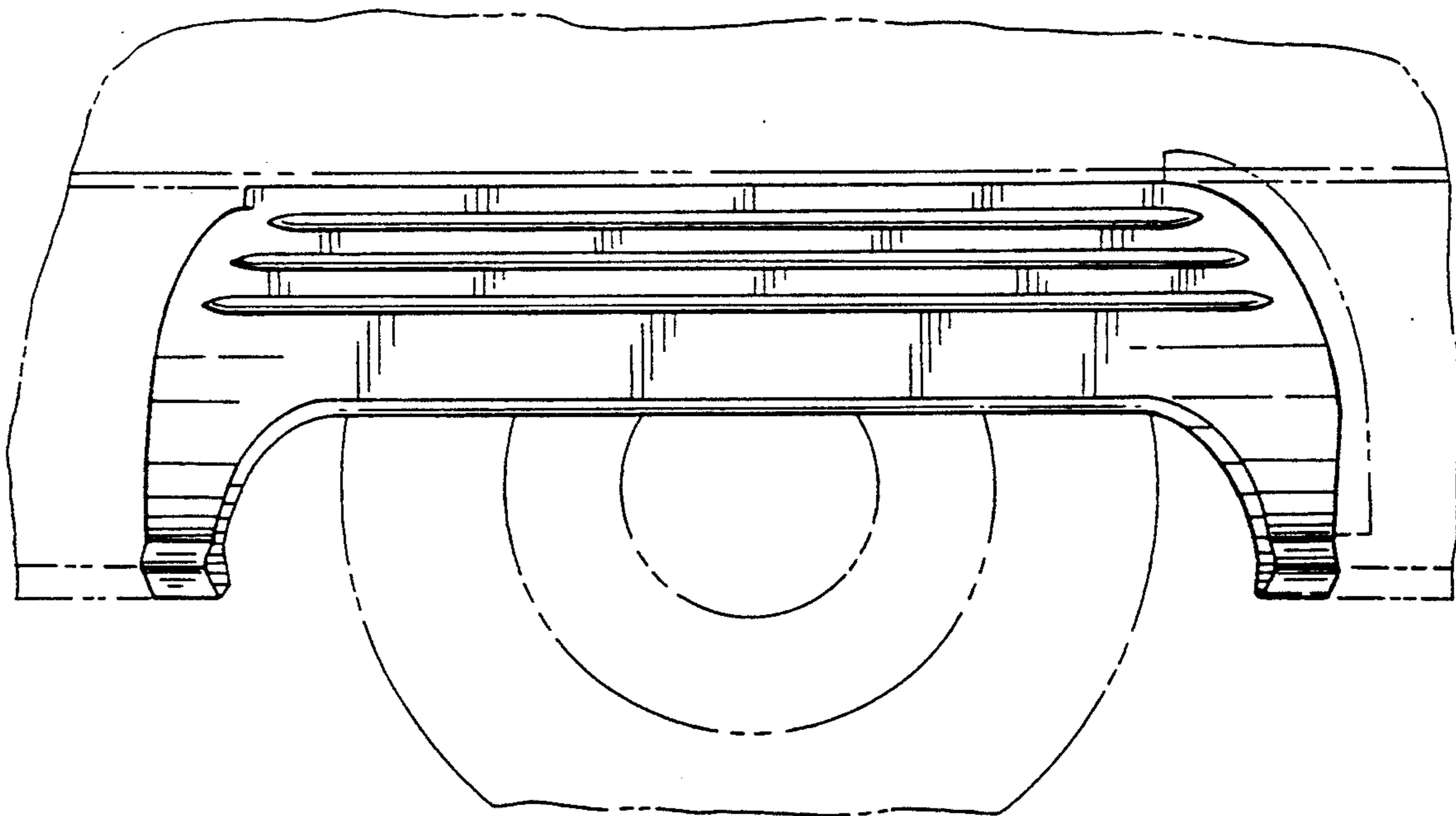

FIG. 4



FIG. 3



FIG. 2

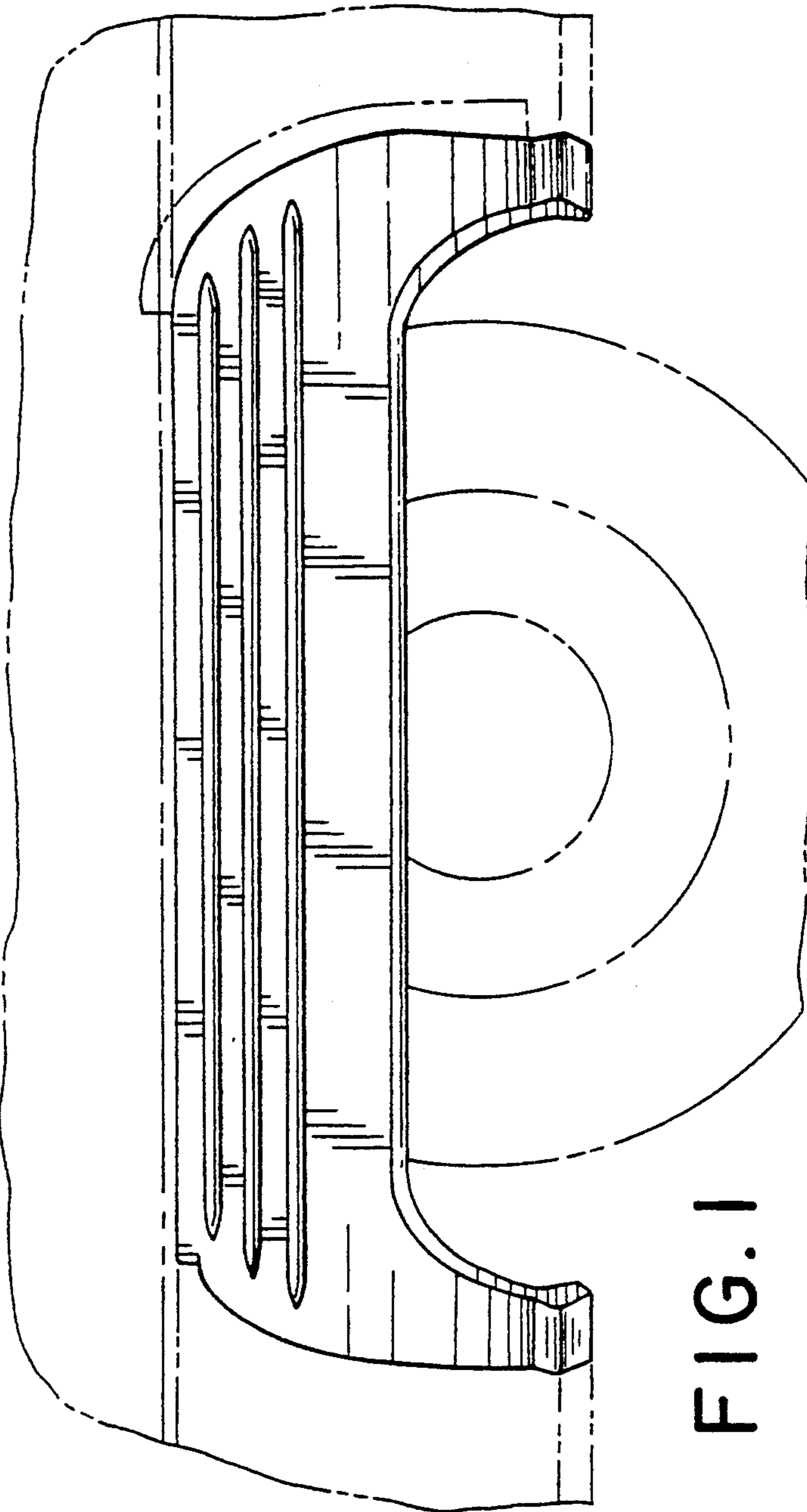

FIG. 1

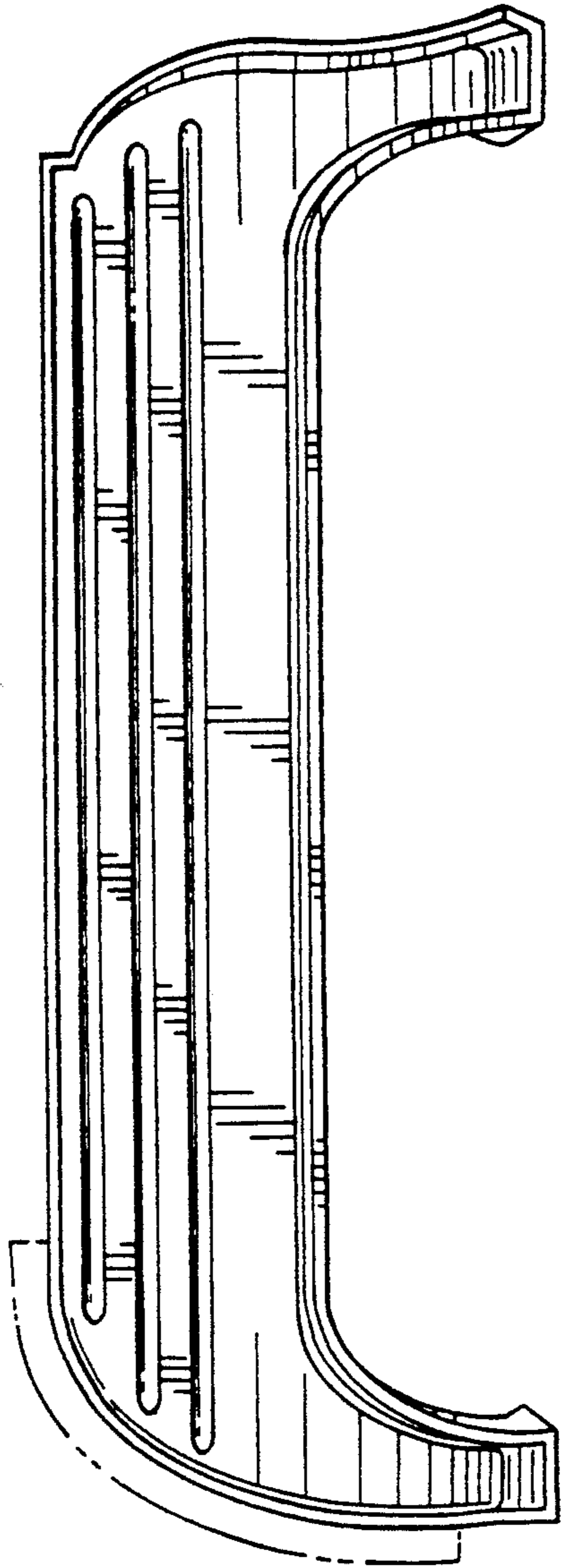

FIG. 5

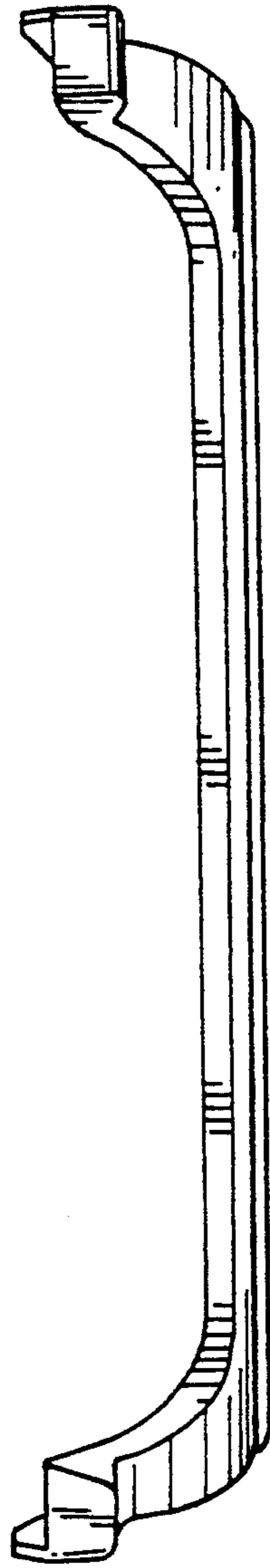

FIG. 6