



US00D345227S

United States Patent [19]

Kramer

[11] Patent Number: Des. 345,227

[45] Date of Patent: ** Mar. 15, 1994

[54] MULTI-SHADE ARC BOOM LAMP

[76] Inventor: Barry L. Kramer, 6180 S. St. Andrews Pl., Los Angeles, Calif. 90047

[**] Term: 14 Years

[21] Appl. No.: 9,771

[22] Filed: Jun. 24, 1993

Related U.S. Application Data

[62] Division of Ser. No. 884,959, May 18, 1992, Pat. No. Des. 341,000.

[52] U.S. Cl. D26/102; D26/128

[58] Field of Search 362/410, 411, 412, 413, 362/414; D26/93, 102-112, 128-136

[56] References Cited

PUBLICATIONS

Best Catalog, 1988/89, p. 165, Arc Floor Lamp #14.
Hammacher Schlemmer Holiday Catalog, p. 68, Banker's Halogen Desk Lamp.
Home Lighting & Accessories, Jul. 1989, p. 109, Easy-lite Arc Floor Lamp.

Primary Examiner—Susan J. Lucas
Attorney, Agent, or Firm—Timothy T. Tyson

[57] CLAIM

The ornamental design for a multi-shade arc boom lamp, as shown and described.

DESCRIPTION

FIG. 1 is a front elevational view of a multishade arc boom lamp showing my new design;
FIG. 2 is a right side elevational view of FIG. 1, the left side elevational view being the mirror image thereof;
FIG. 3 is a top plan view of FIG. 1;
FIG. 4 is a bottom plan view of FIG. 1;
FIG. 5 is a rear elevational view of FIG. 1;
FIG. 6 is an enlarged top plan view of a single shade of FIG. 1;
FIG. 7 is an enlarged side elevational view of a single shade of FIG. 1;

FIG. 8 is a bottom plan view of a single shade of FIG. 1;
FIG. 9 is a front elevational view of a second embodiment thereof;
FIG. 10 is a right side elevational view of FIG. 9, the left side elevational view being the mirror image thereof;
FIG. 11 is a top plan view of FIG. 9;
FIG. 12 is a bottom plan view of FIG. 9;
FIG. 13 is a rear elevational view of FIG. 9;
FIG. 14 is an enlarged top plan view of a single shade of FIG. 9;
FIG. 15 is an enlarged side elevational view of a single shade of FIG. 9;
FIG. 16 is a bottom plan view of a single shade of FIG. 9;
FIG. 17 is a front elevational view of a third embodiment thereof;
FIG. 18 is a right side elevational view of FIG. 17, the left side elevational view being the mirror image thereof;
FIG. 19 is a top plan view of FIG. 17;
FIG. 20 is a bottom plan view of FIG. 17;
FIG. 21 is a rear elevational view of FIG. 17;
FIG. 22 is an enlarged top plan view of a single shade of FIG. 17;
FIG. 23 is an enlarged side elevational view of a single shade of FIG. 17;
FIG. 24 is a bottom plan view of a single shade of FIG. 17;
FIG. 25 is a front elevational view of a fourth embodiment thereof;
FIG. 26 is a right side elevational view of FIG. 25, the left side elevational view being the mirror image thereof;
FIG. 27 is a top plan view of FIG. 25;
FIG. 28 is a bottom plan view of FIG. 25;
FIG. 29 is a rear elevational view of FIG. 25;
FIG. 30 is an enlarged top plan view of a single shade of FIG. 25;
FIG. 31 is an enlarged side elevational view of a single shade of FIG. 25; and,
FIG. 32 is a bottom plan view of a single shade of FIG. 25.

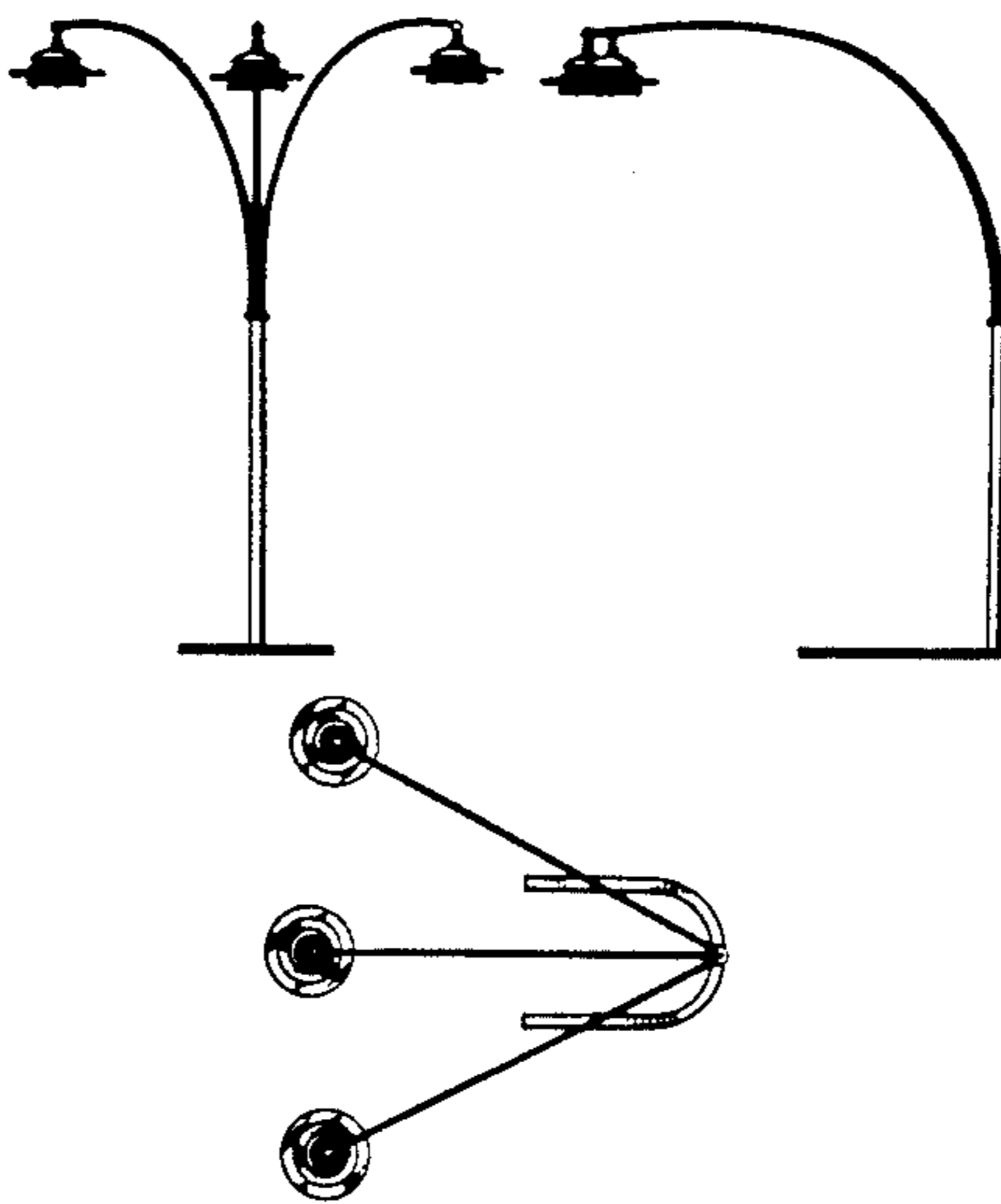

FIG. 1

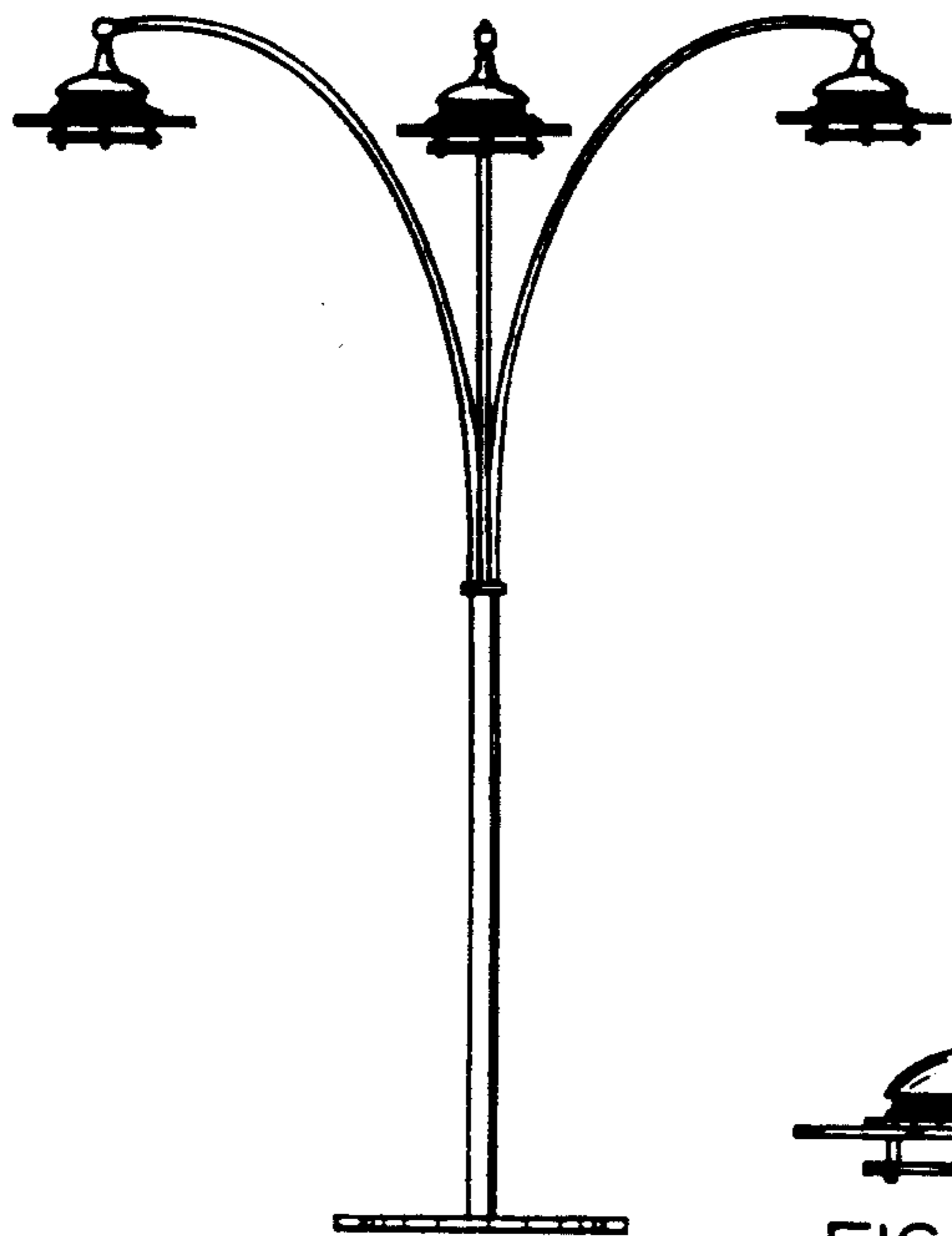

FIG. 2

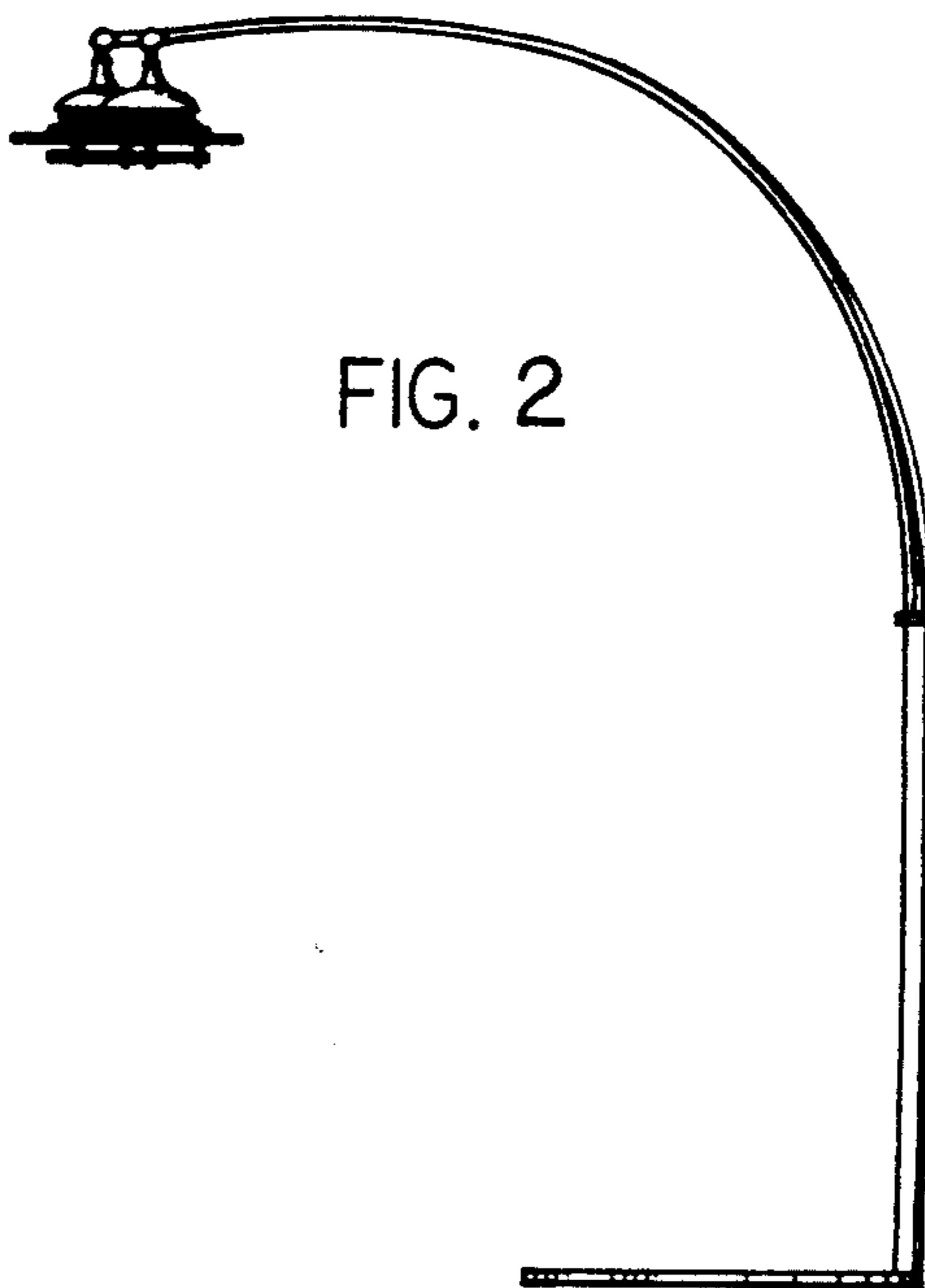

FIG. 7

FIG. 8

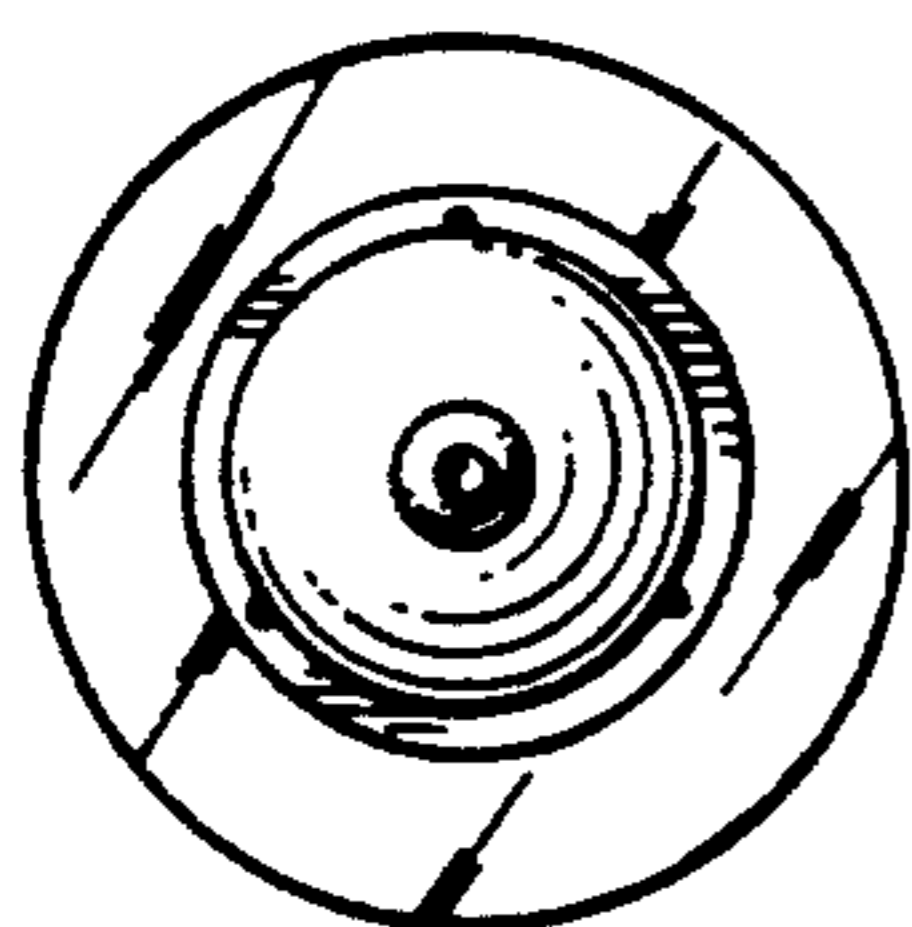
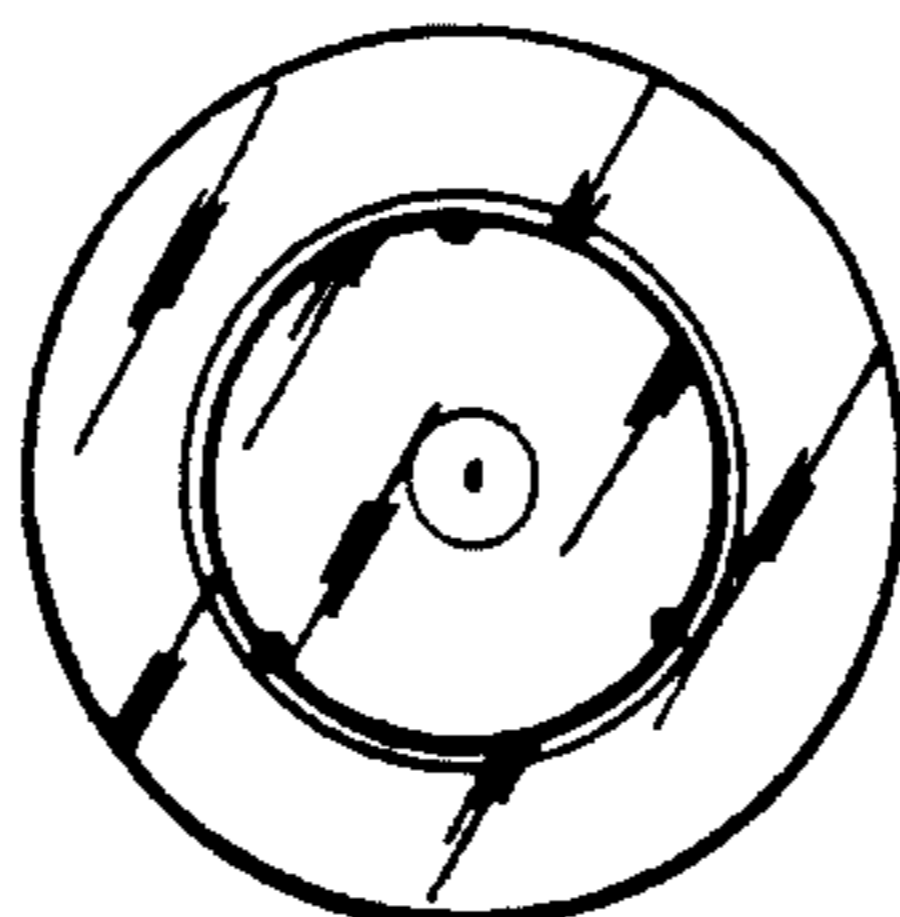

FIG. 6

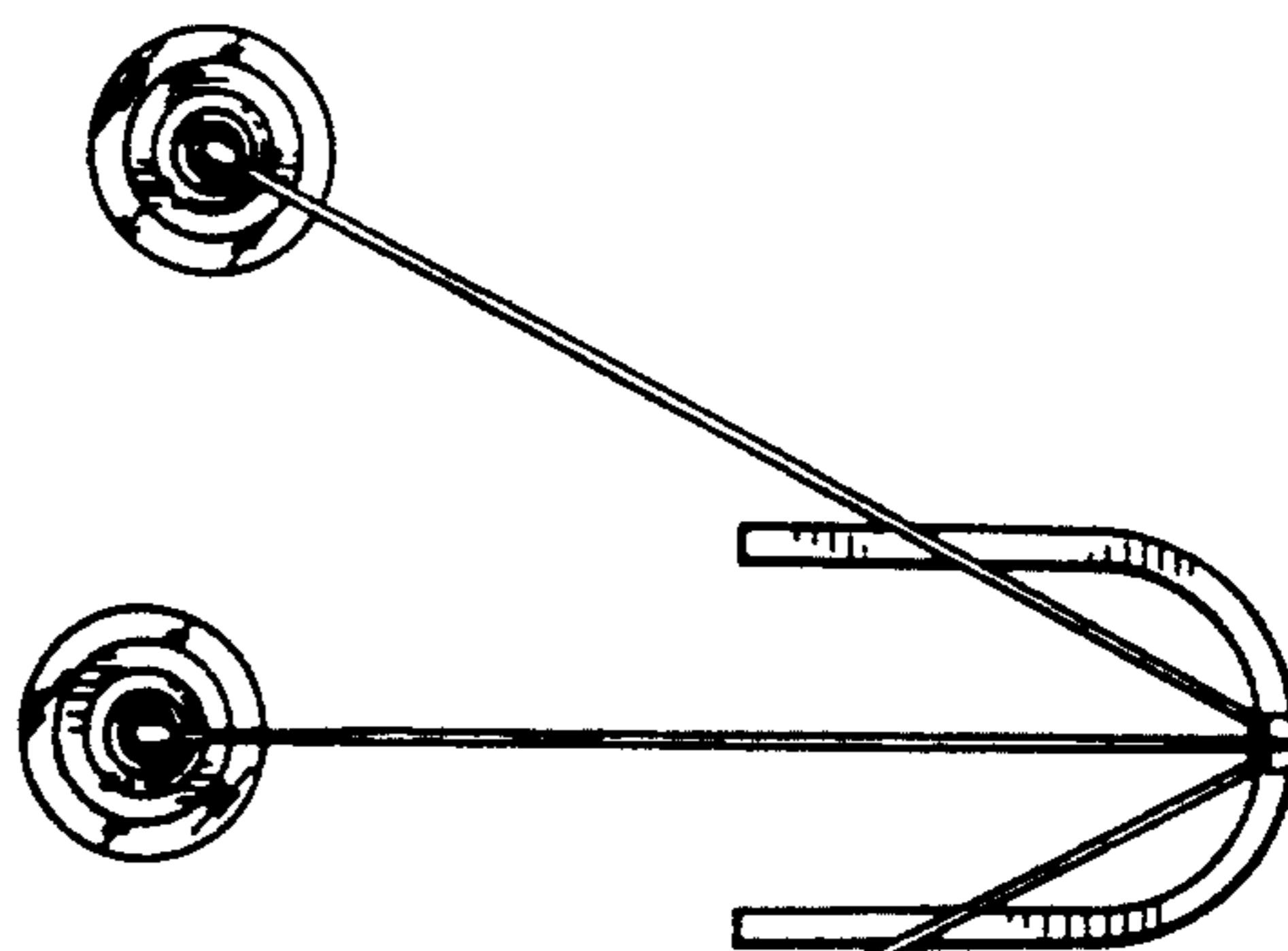

FIG. 3

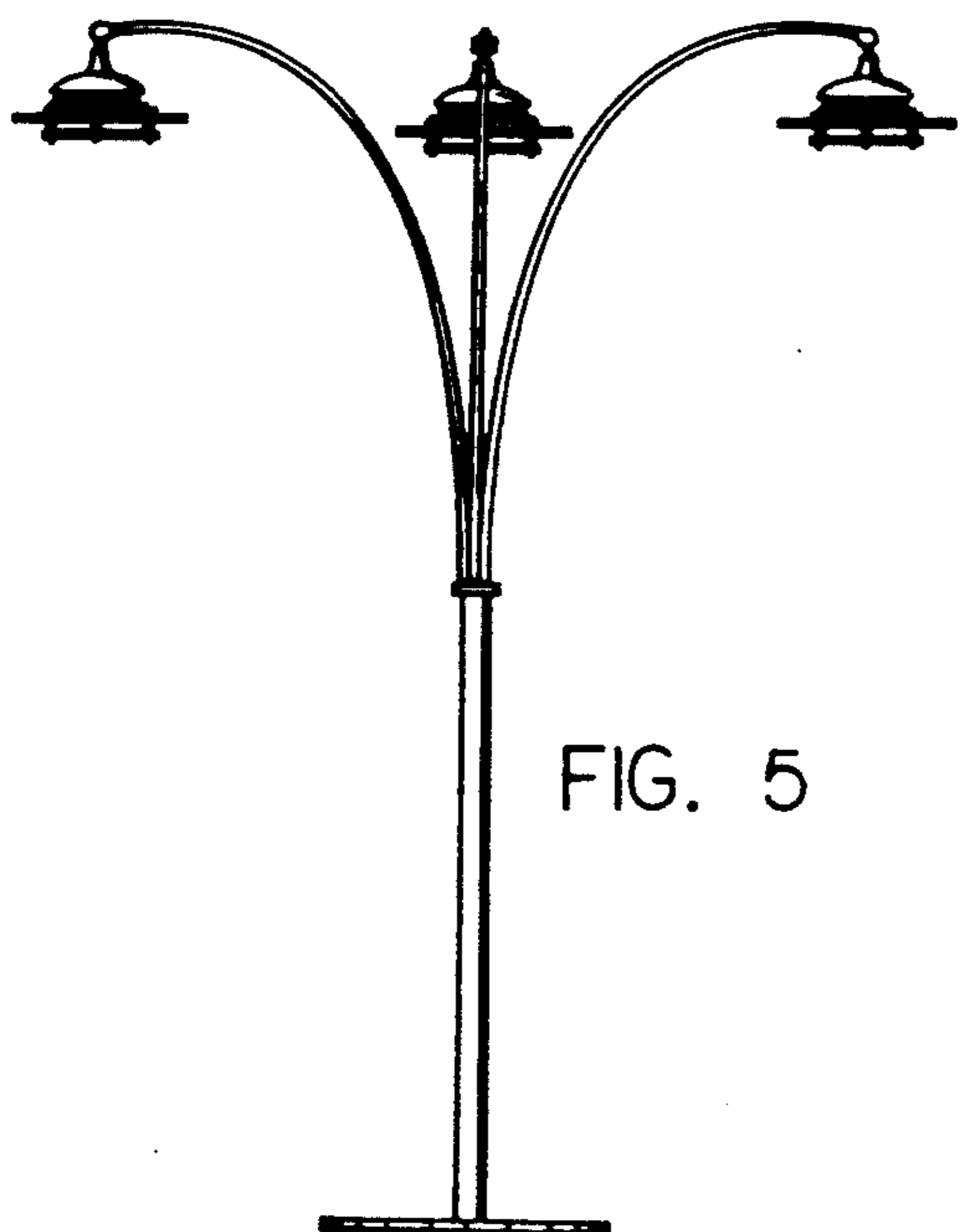

FIG. 5

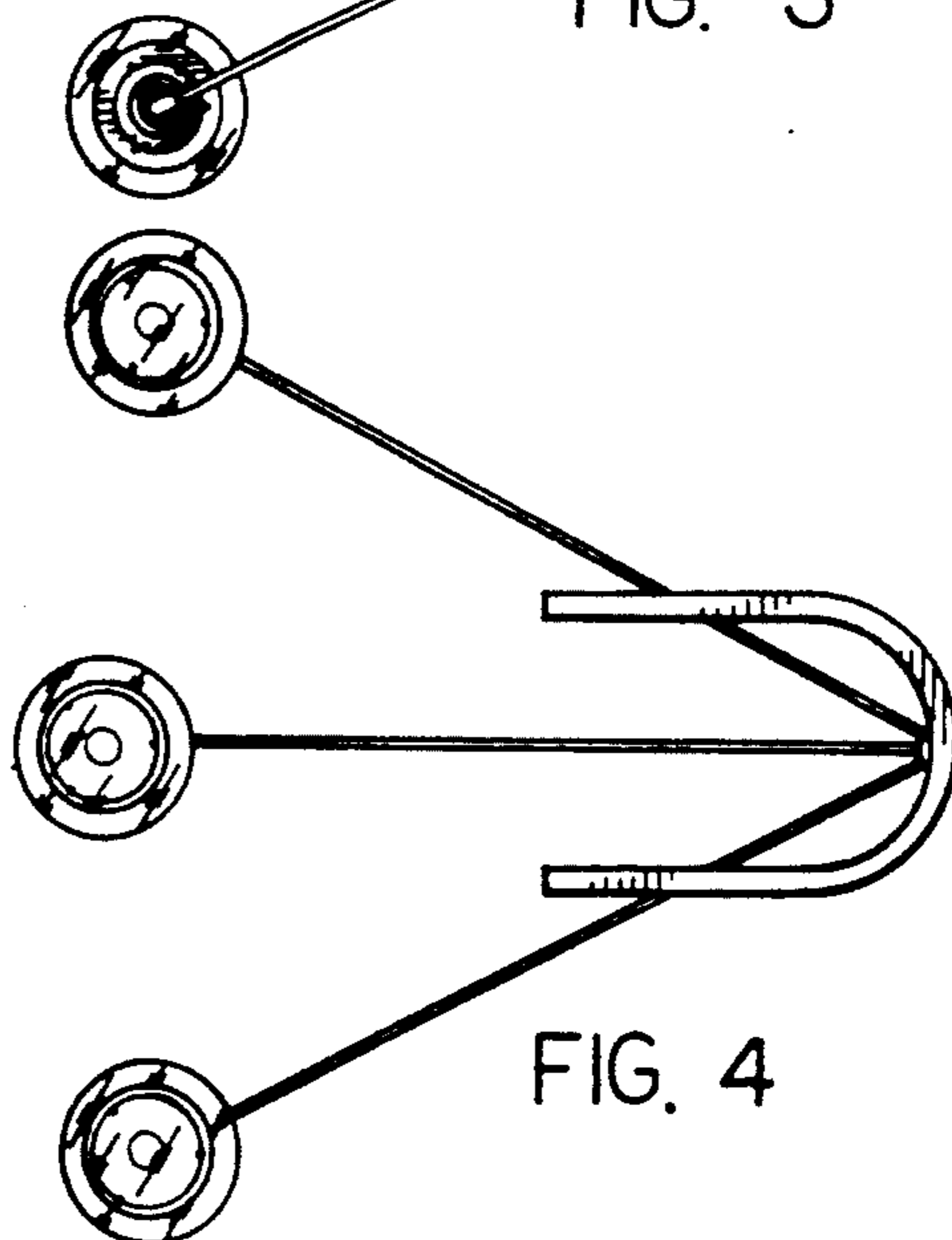

FIG. 4

FIG. 9

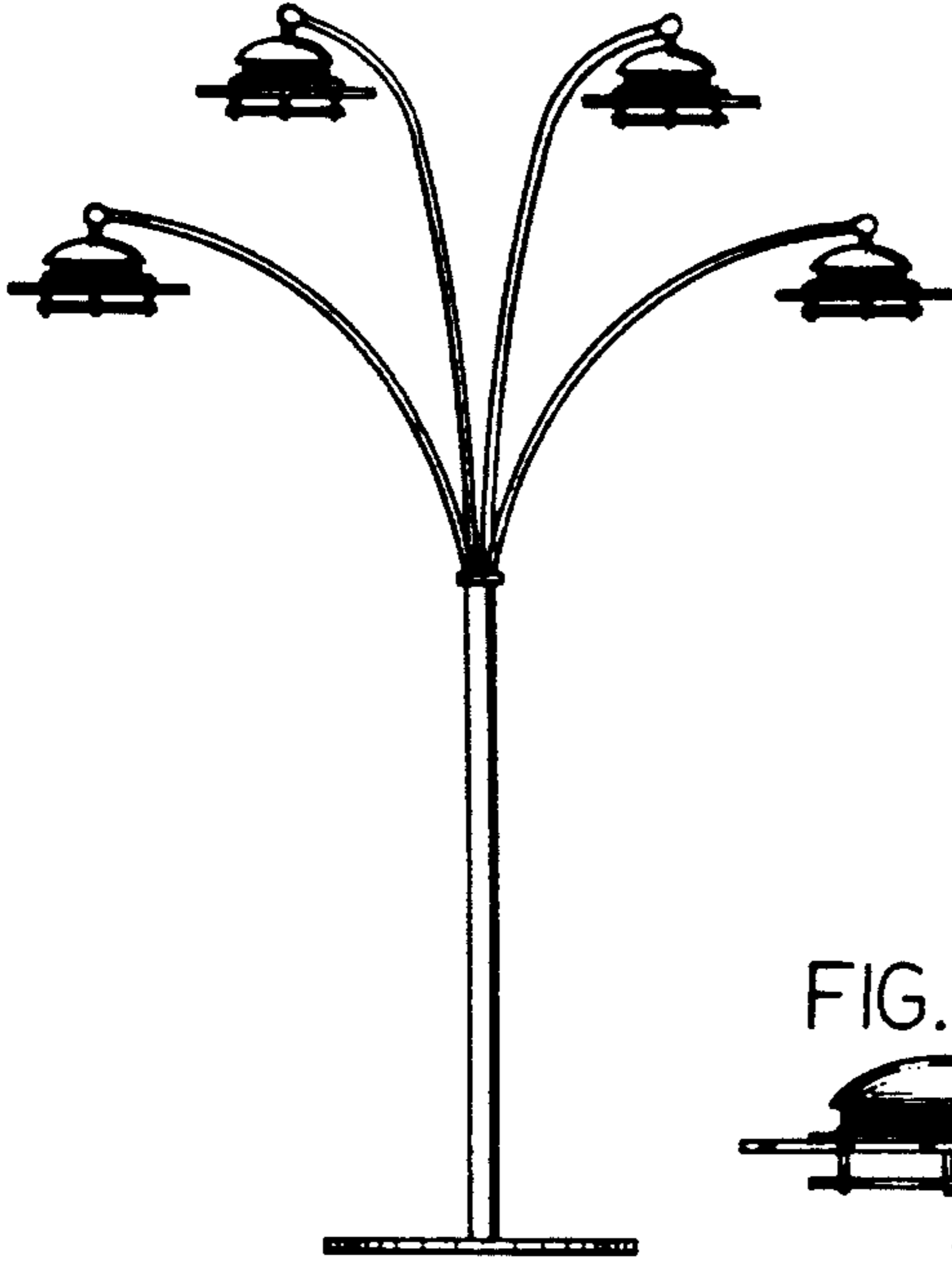

FIG. 10

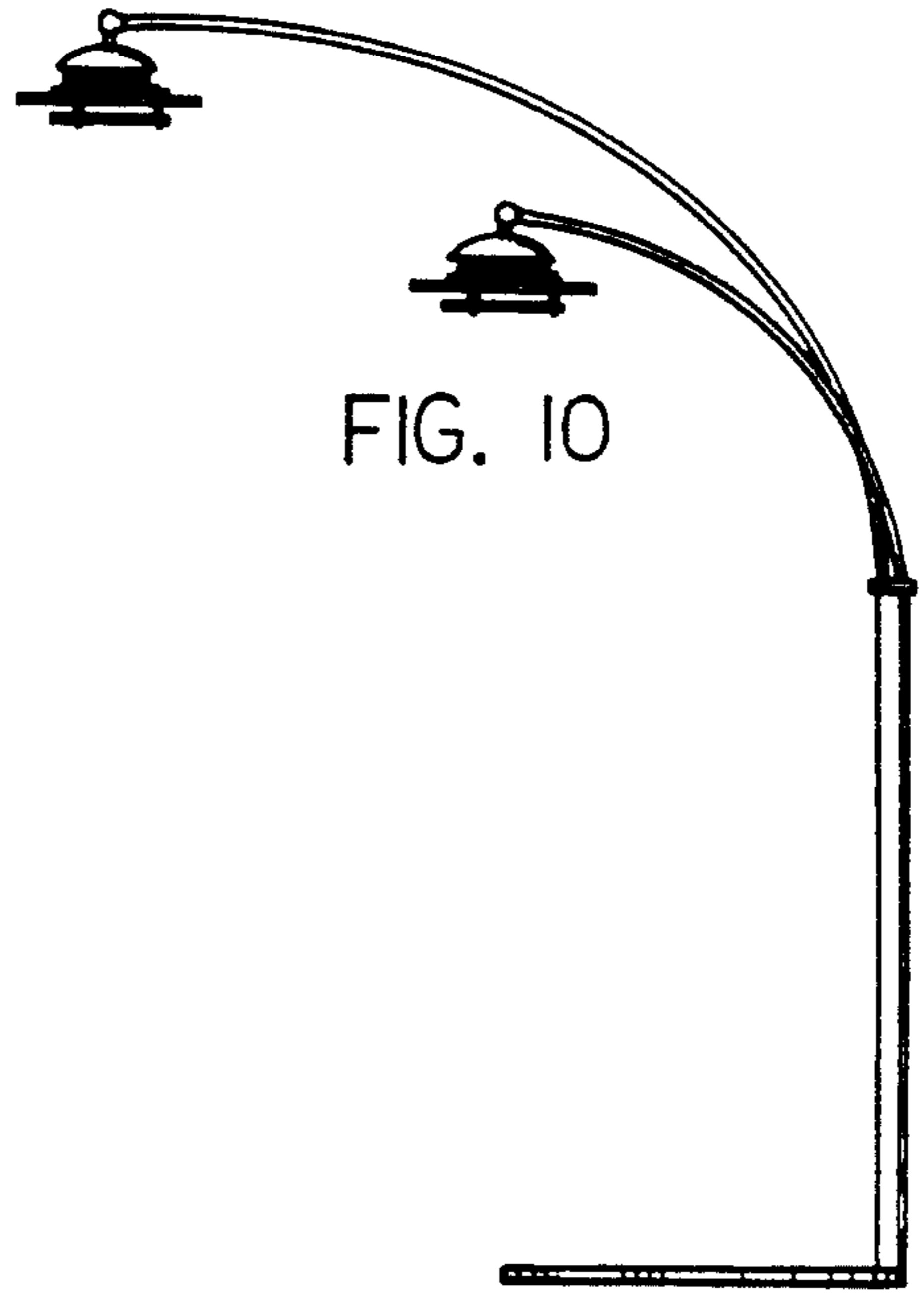

FIG. 15

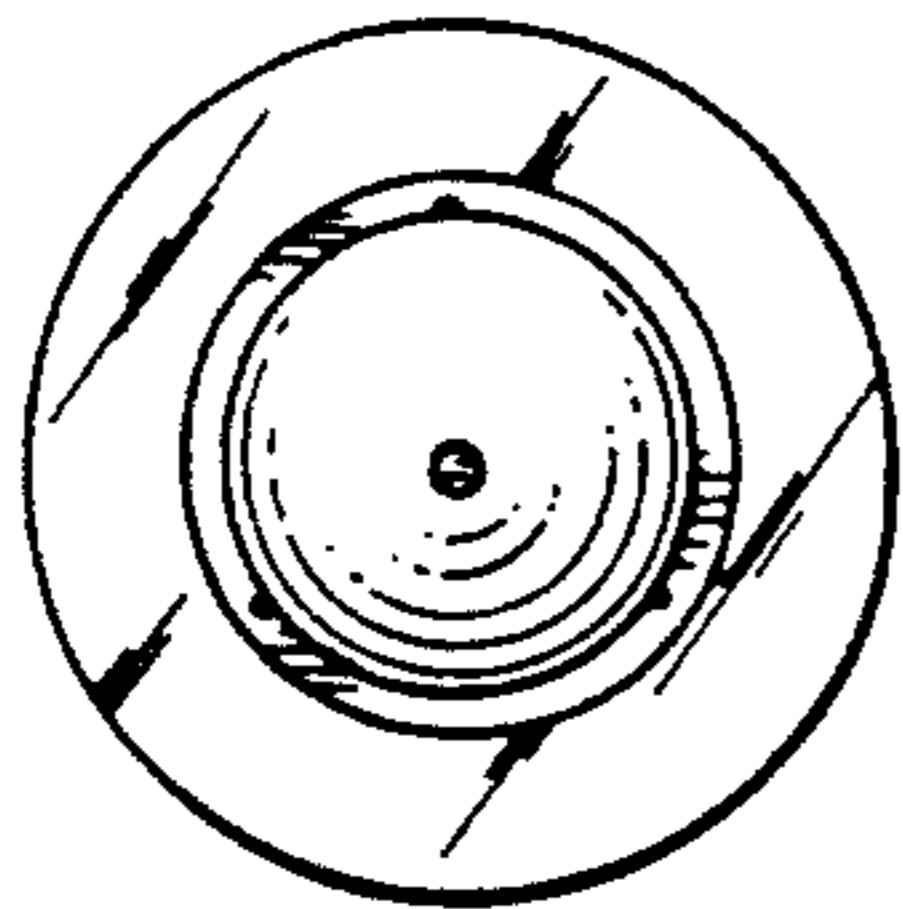

FIG. 14

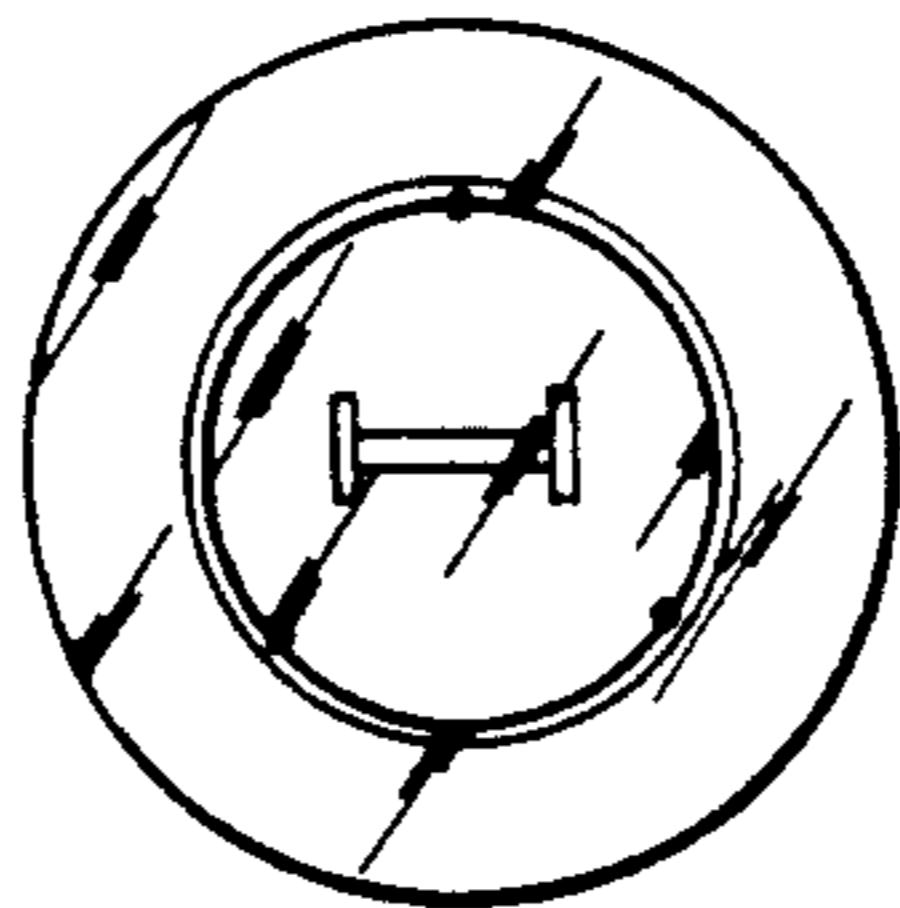

FIG. 16

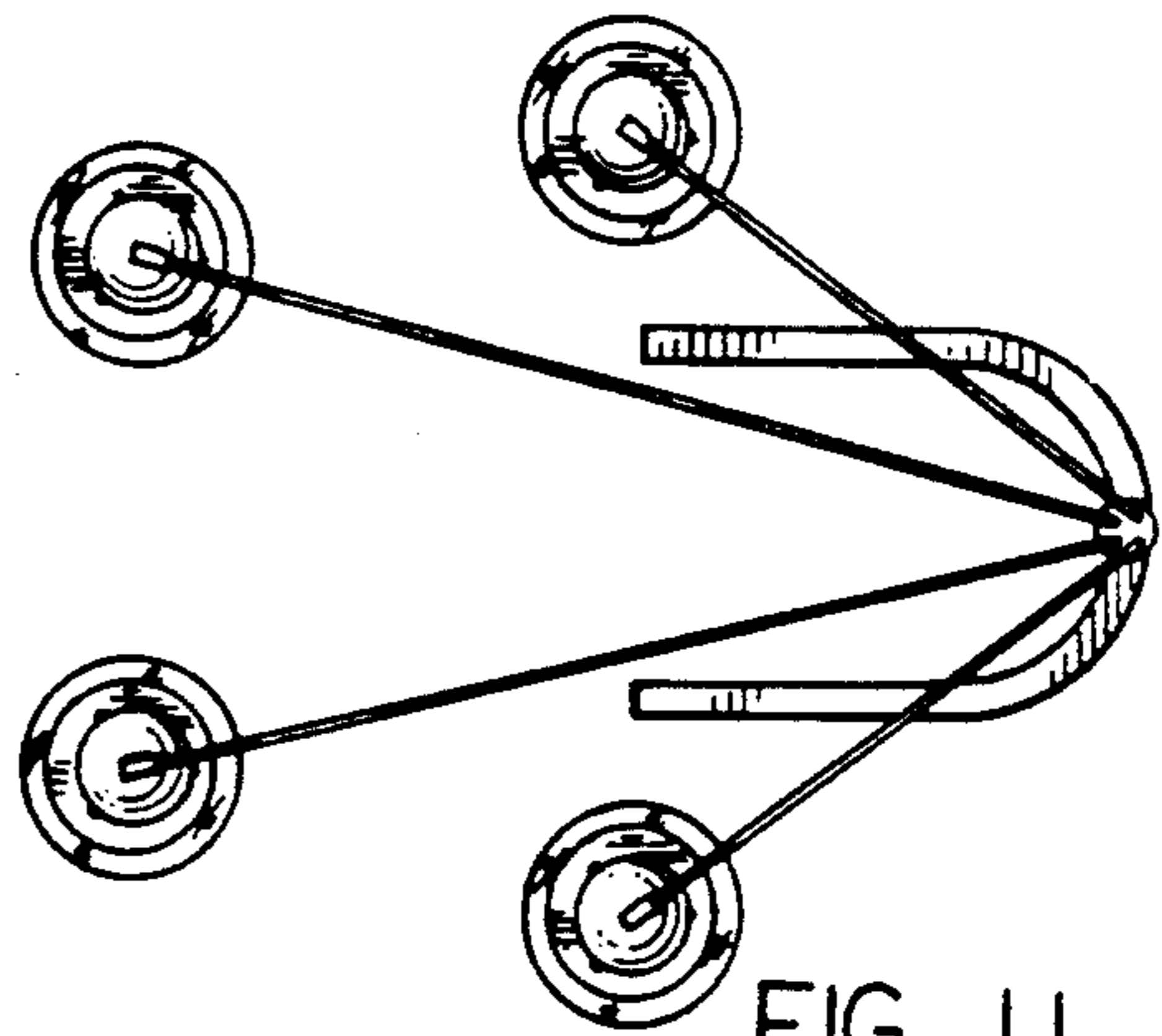

FIG. 11

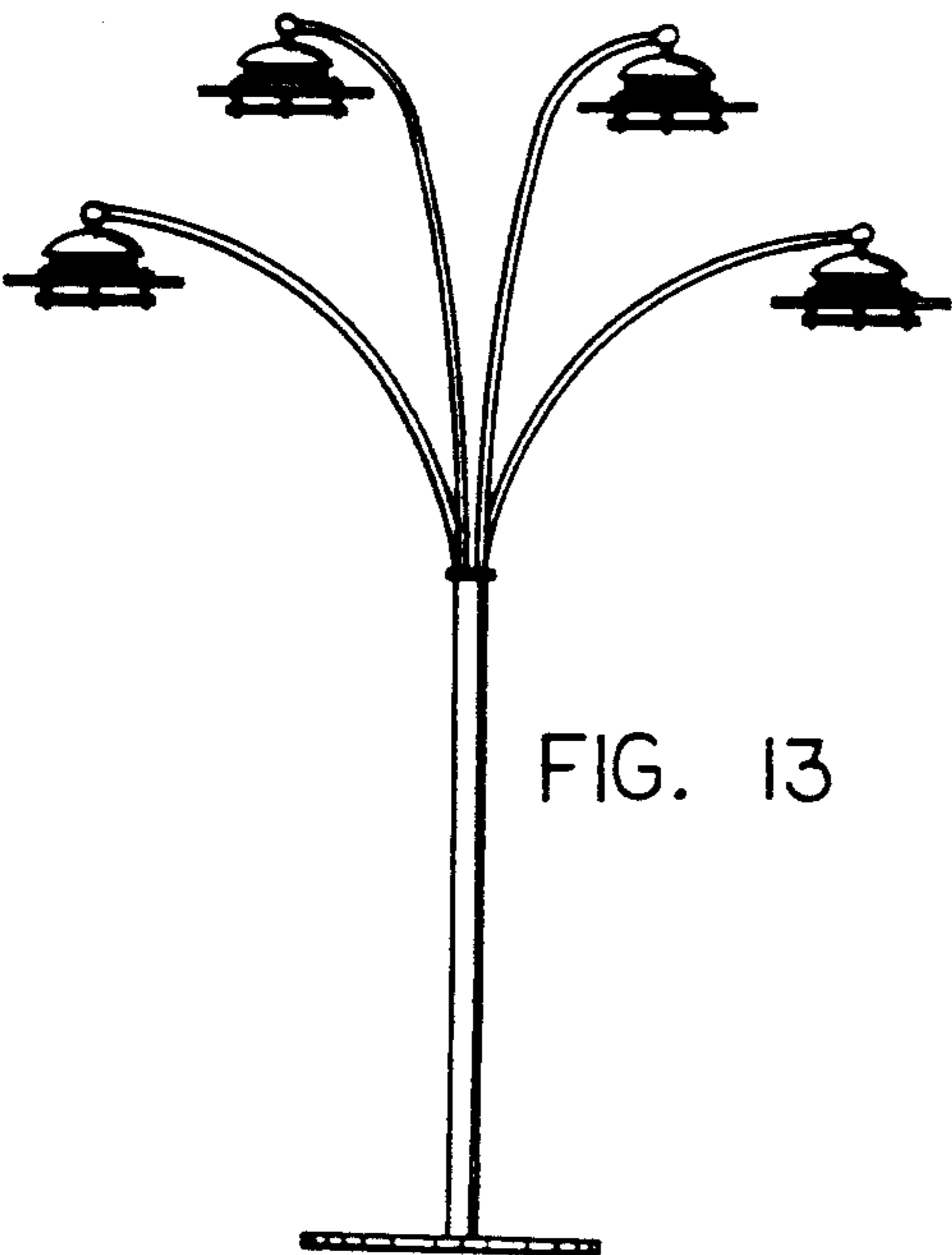

FIG. 13

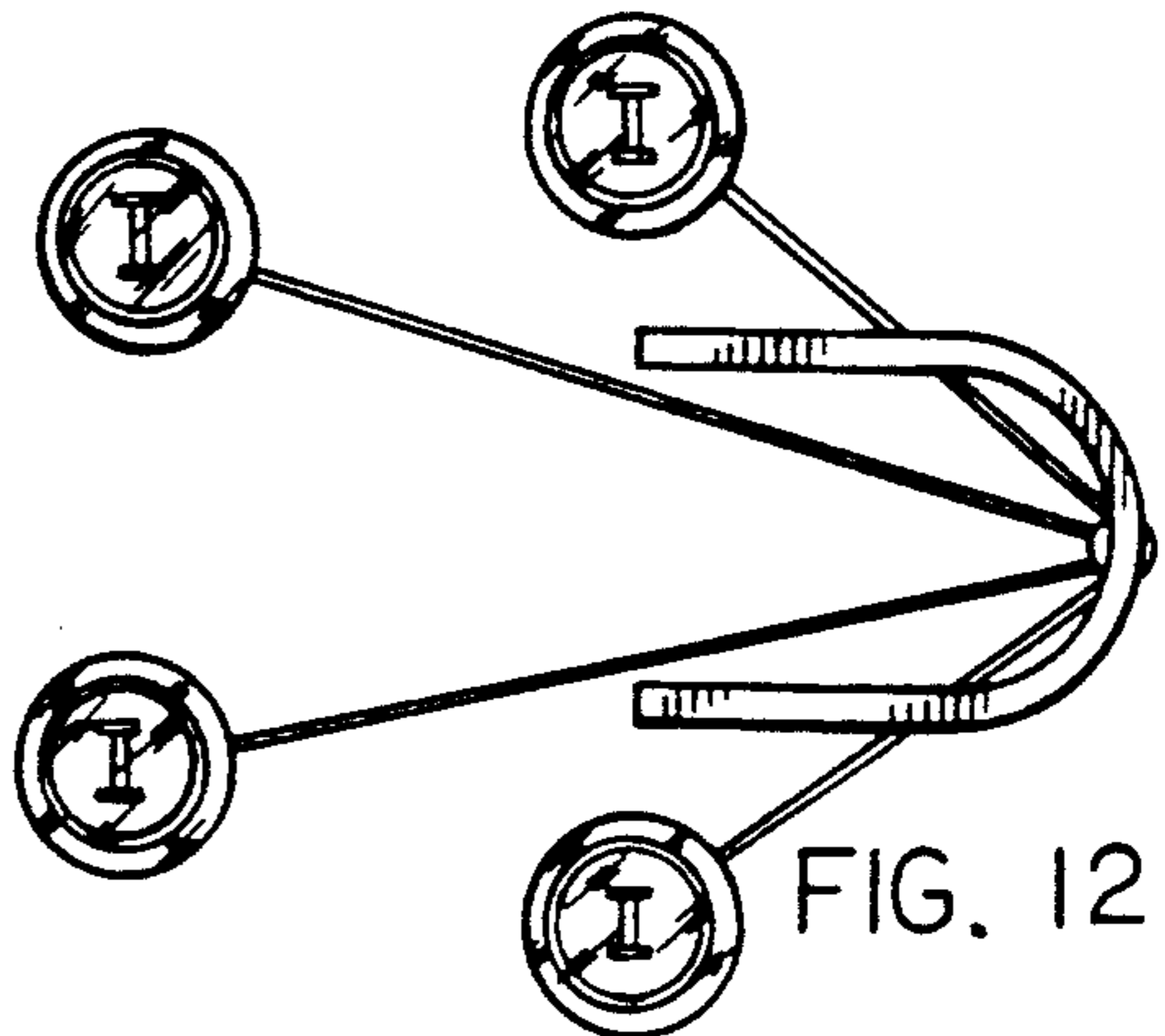

FIG. 12

FIG. 17

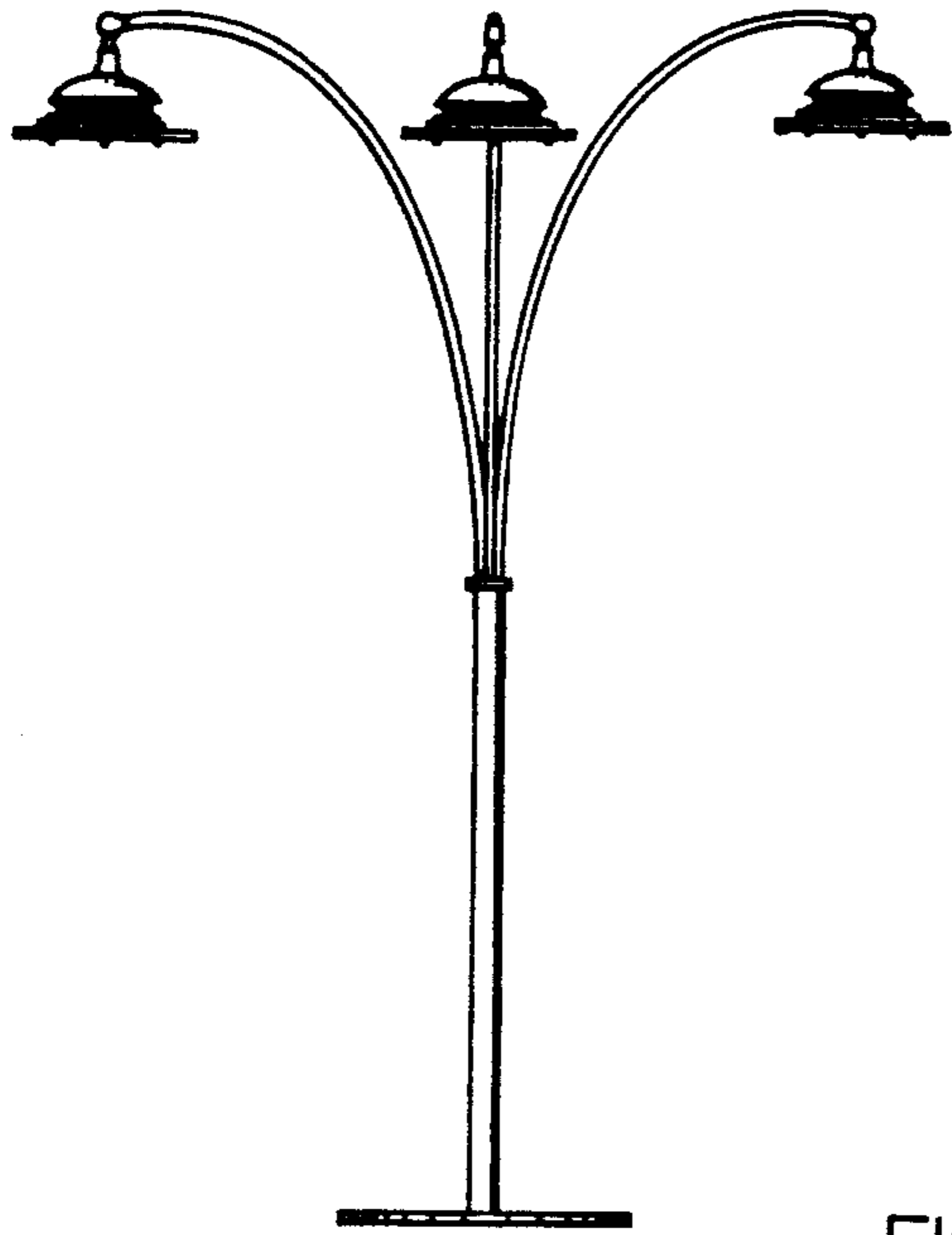

FIG. 18

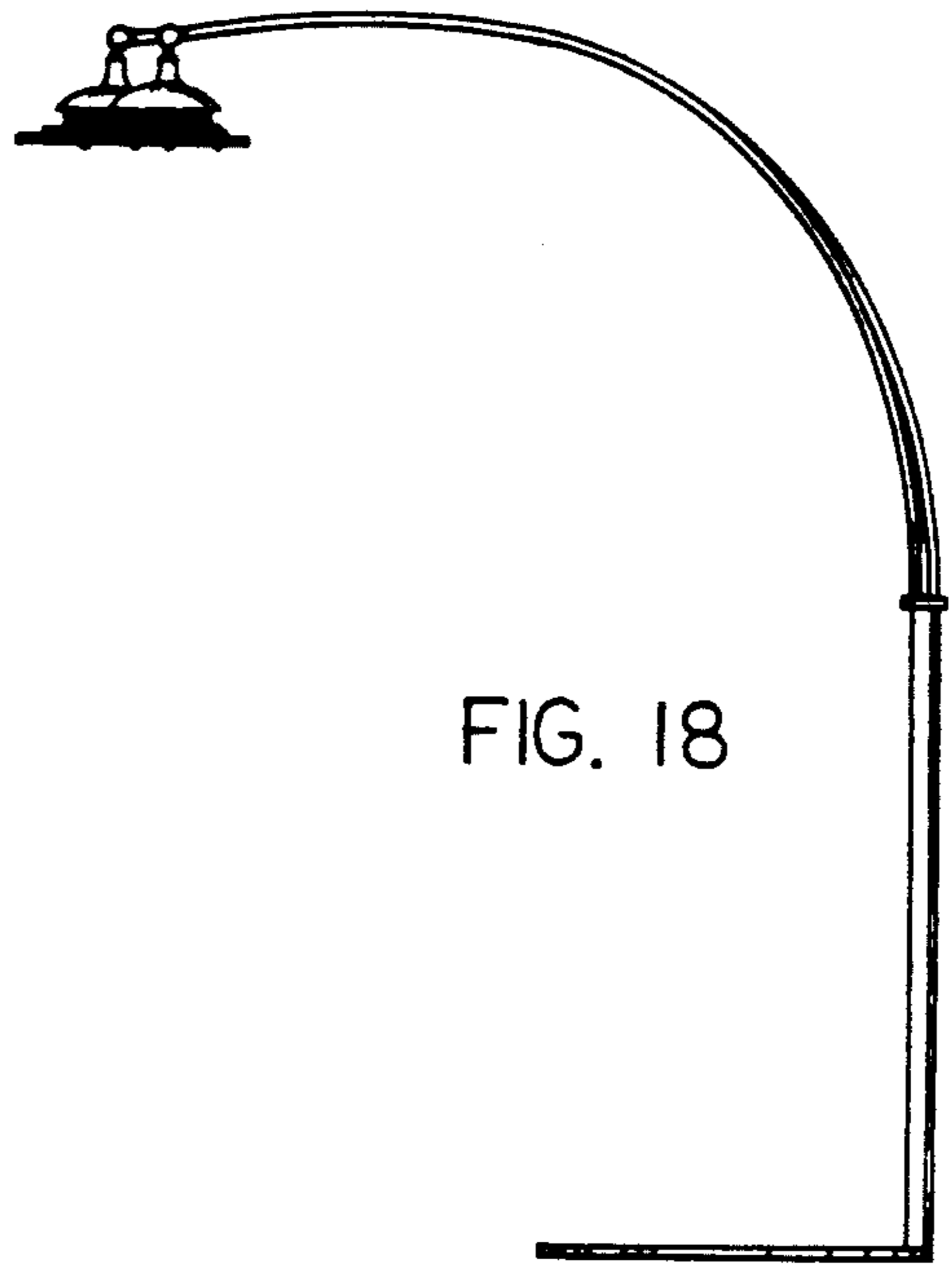

FIG. 23

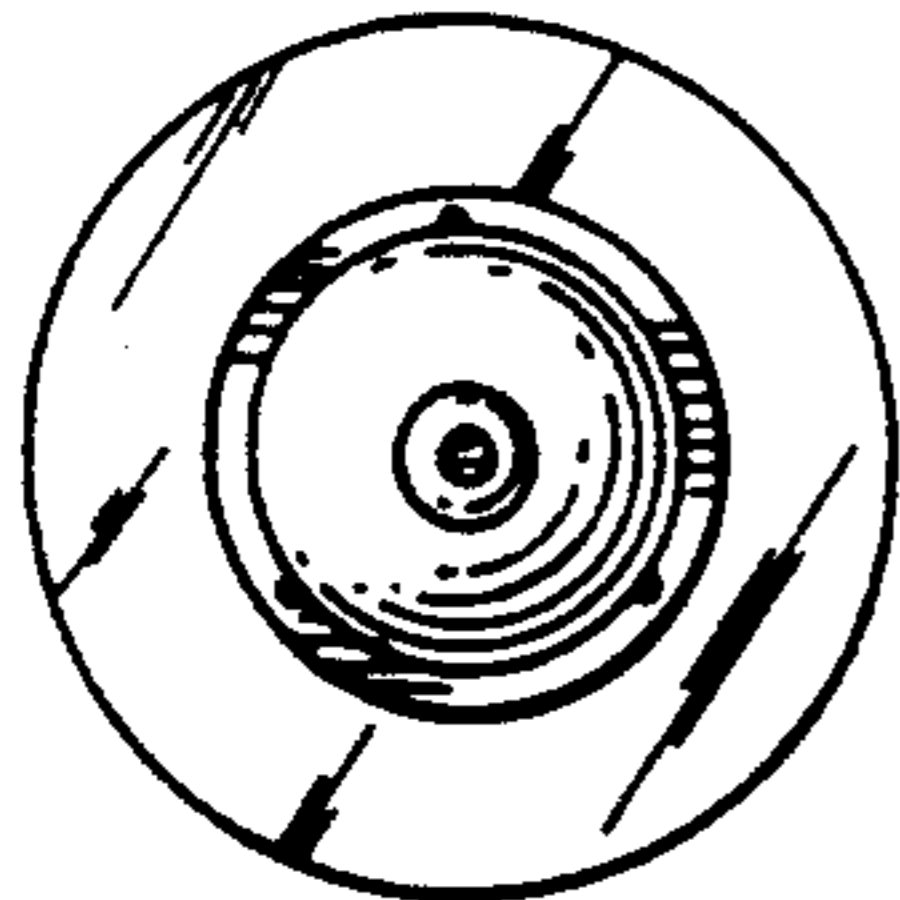

FIG. 22

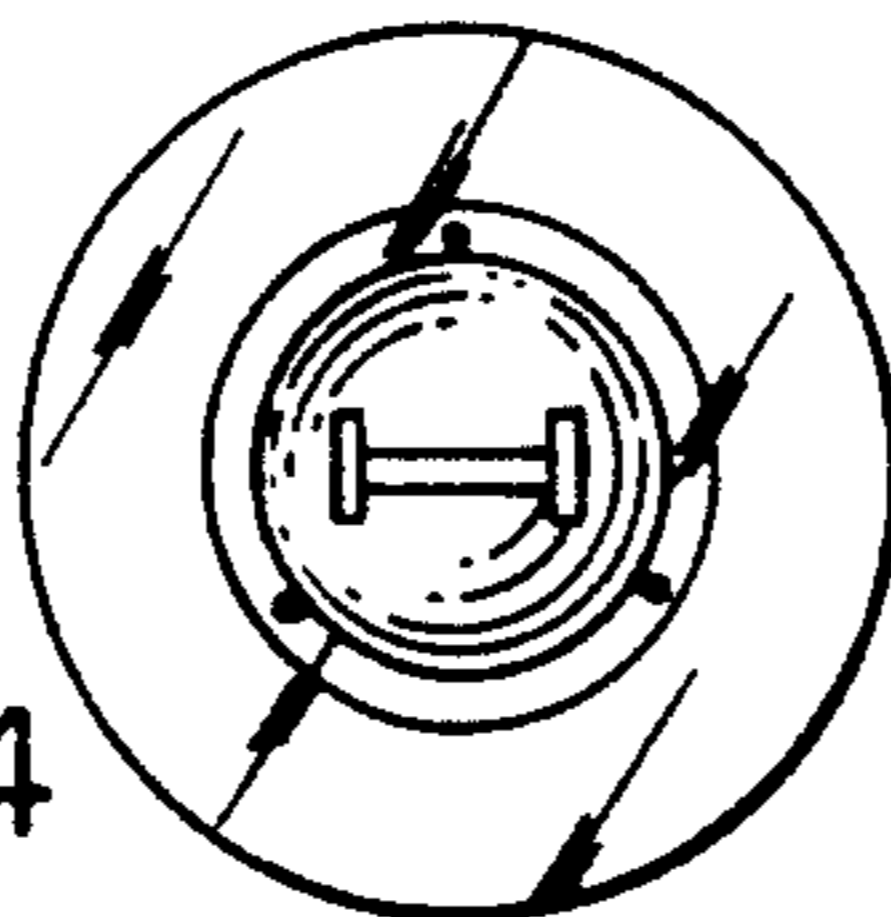

FIG. 24

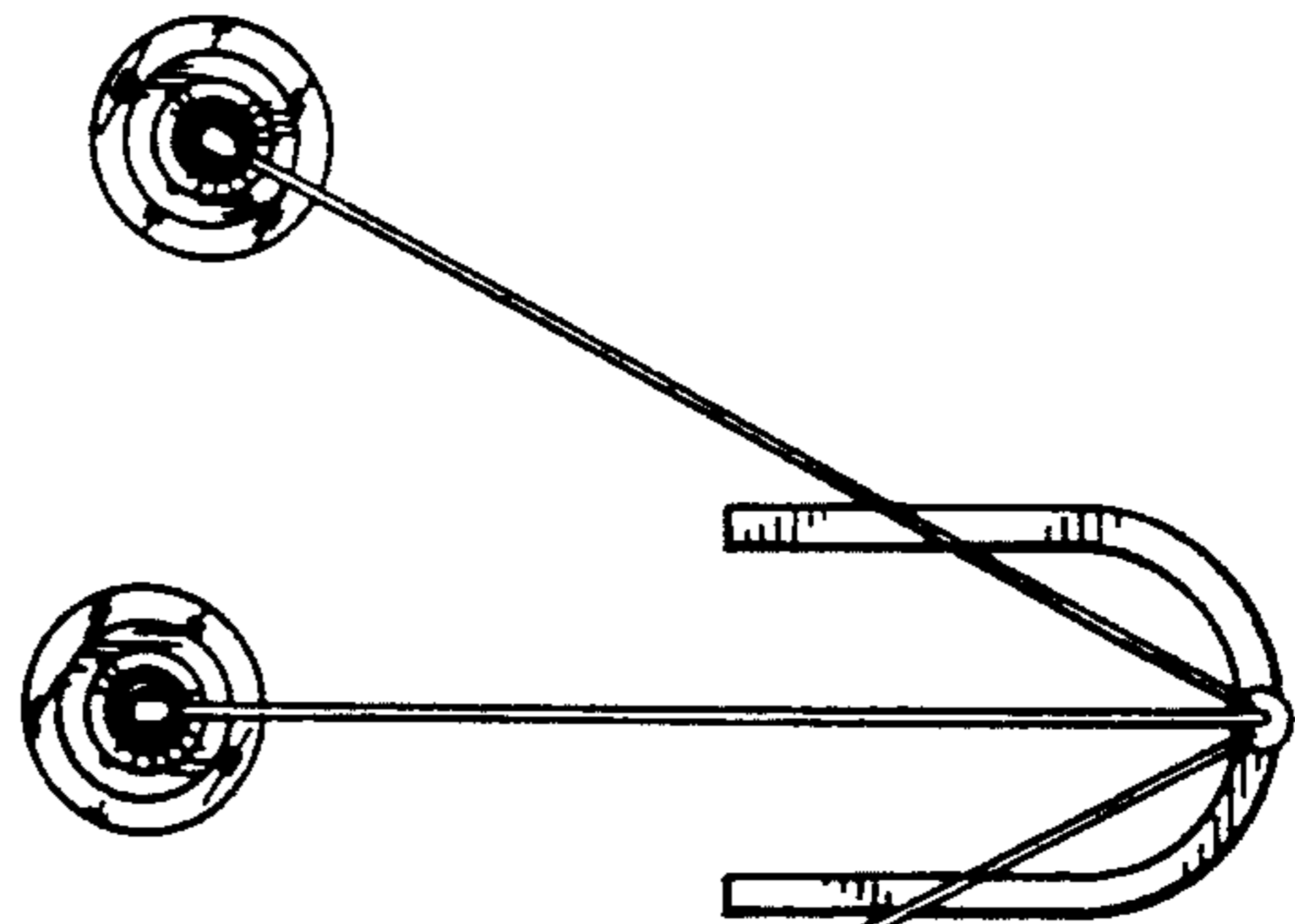

FIG. 19

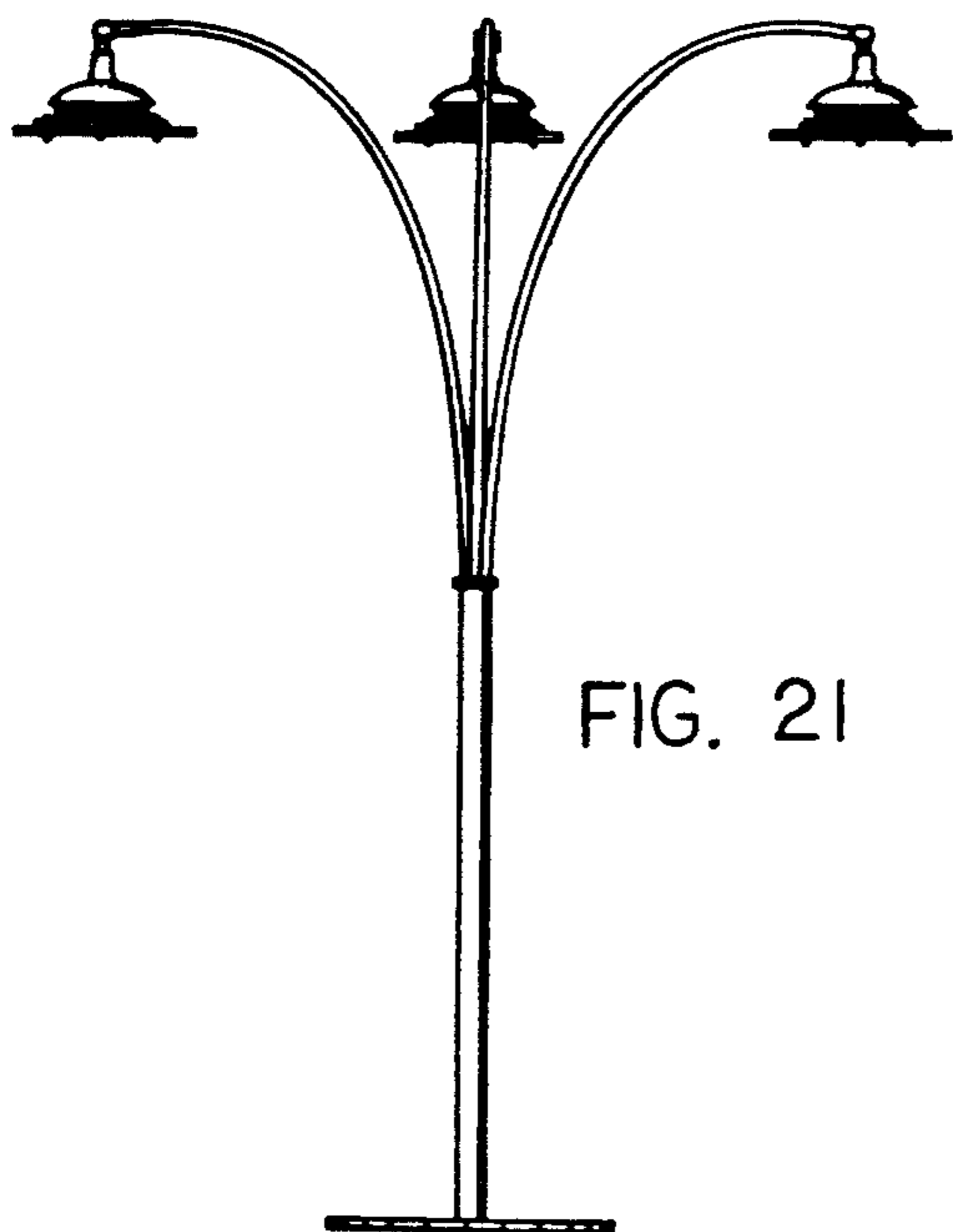

FIG. 21

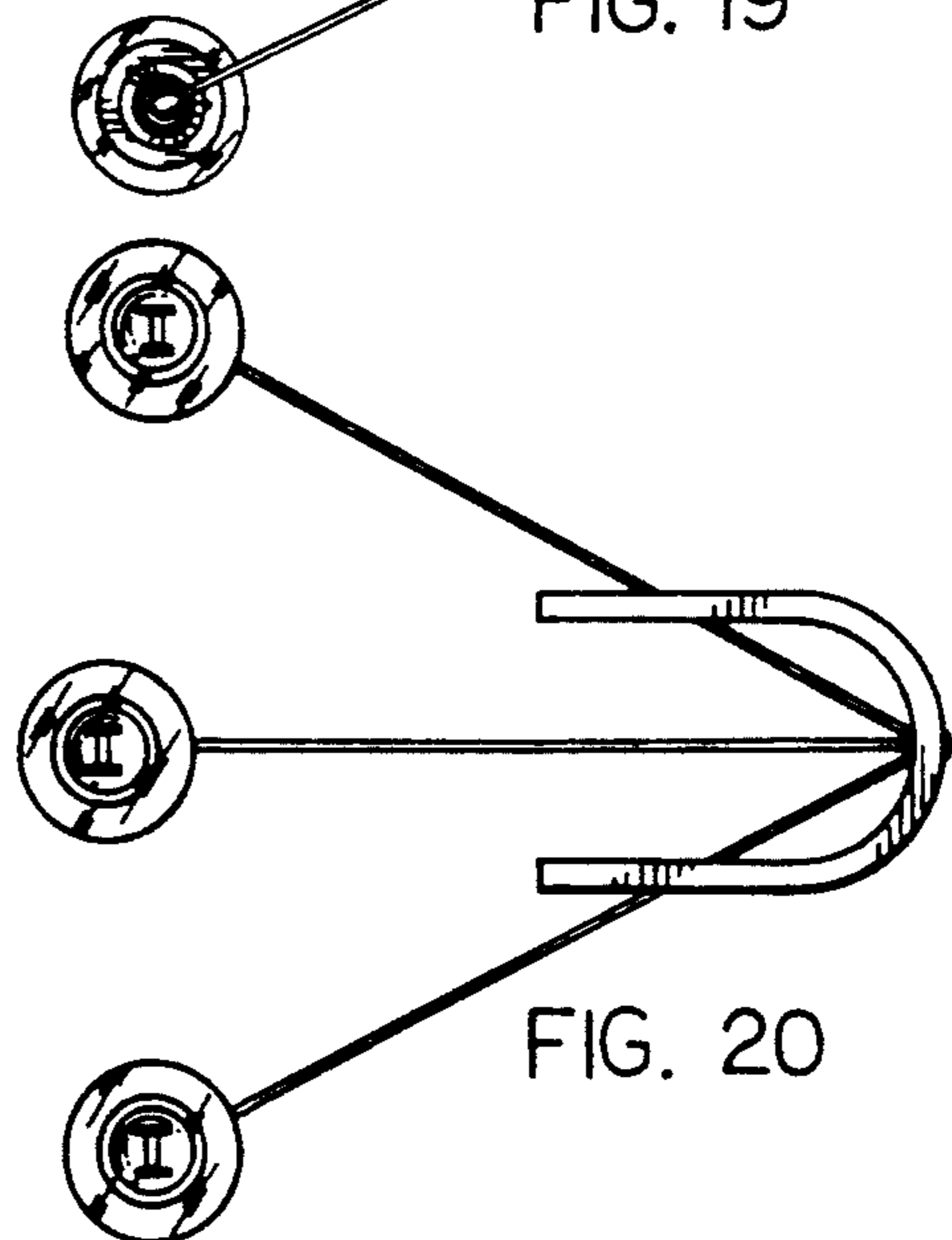

FIG. 20

