



US00D345201S

United States Patent [19]

Kardos et al.

[11] Patent Number: **Des. 345,201**

[45] Date of Patent: **** Mar. 15, 1994**

[54] **HORIZONTAL PULSE COMBUSTION BOILER**

4,846,150 7/1989 Maton 126/362
4,926,798 5/1990 Kardos 122/24

[75] Inventors: **Peter Kardos**, Longmeadow, Mass.;
Masoud Tamjidi, Liverpool, N.Y.

Primary Examiner—Wallace R. Burke
Assistant Examiner—Lisa Lichtenstein
Attorney, Agent, or Firm—Speckman, Pauley & Fejer

[73] Assignee: **Fulton Thermatec Corporation**,
Pulaski, N.Y.

[57] **CLAIM**

[**] Term: **14 Years**

The ornamental design for a horizontal pulse combustion boiler, as shown and described.

[21] Appl. No.: **689,321**

DESCRIPTION

[22] Filed: **Apr. 22, 1991**

Related U.S. Application Data

[63] Continuation-in-part of Ser. No. 643,663, Jan. 18, 1991,
abandoned.

[52] U.S. Cl. **D23/319**

[58] Field of Search 126/344, 361; 431/1;
D23/319

FIG. 1 is a front view of a horizontal pulse combustion boiler, according to one preferred embodiment of this invention;

FIG. 2 is a bottom view of the horizontal pulse combustion boiler, as shown in FIG. 1;

FIG. 3 is a top view of the horizontal pulse combustion boiler, as shown in FIG. 1;

FIG. 4 is a side view of the horizontal pulse combustion boiler, as shown in FIG. 1;

FIG. 5 is a side view, opposite the side view shown in FIG. 3, of the horizontal pulse combustion boiler;

FIG. 6 is a front view of a horizontal pulse combustion boiler, according to another preferred embodiment of this invention;

FIG. 7 is a bottom view of the horizontal pulse combustion boiler, as shown in FIG. 6;

FIG. 8 is a top view of the horizontal pulse combustion boiler, as shown in FIG. 6;

FIG. 9 is a side view of the horizontal pulse combustion boiler, as shown in FIG. 6; and,

FIG. 10 is a side view, opposite the side view shown in FIG. 9, of the horizontal pulse combustion boiler.

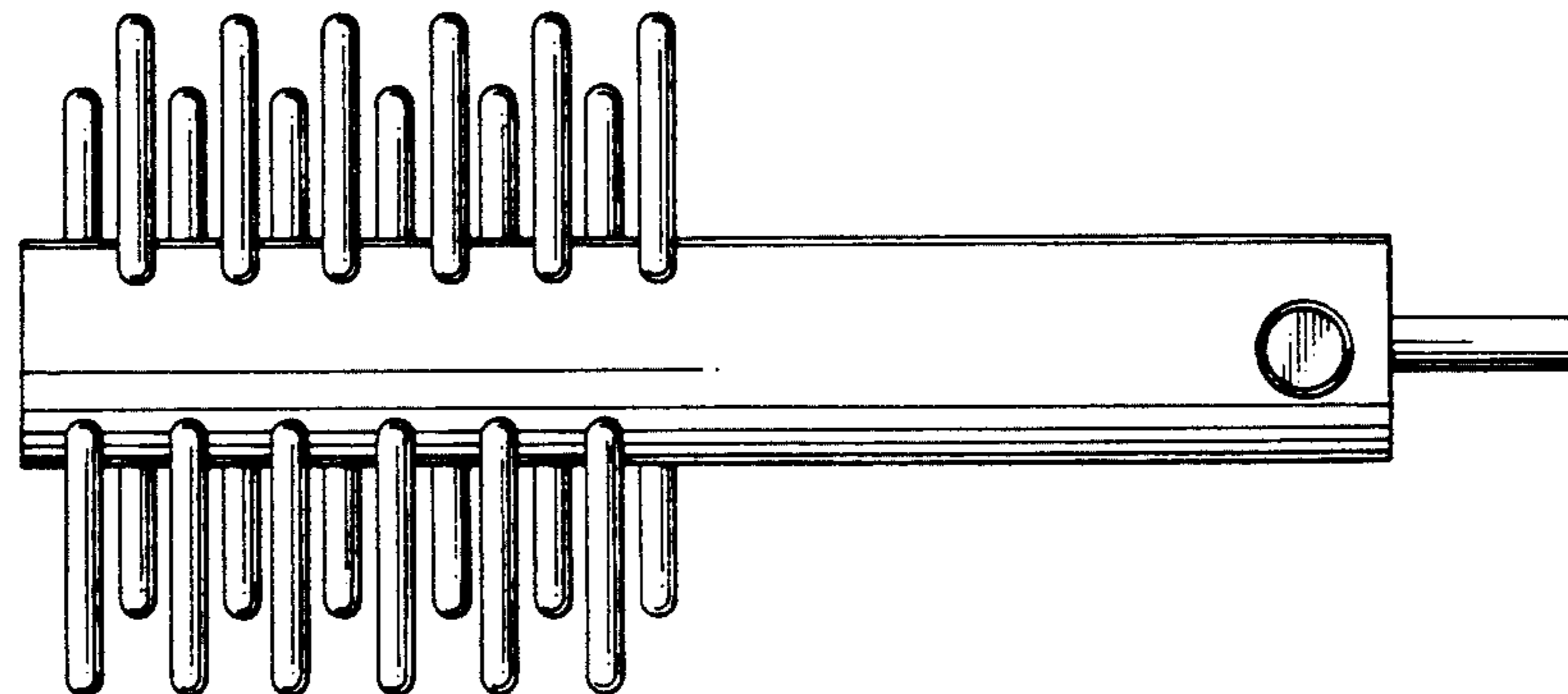
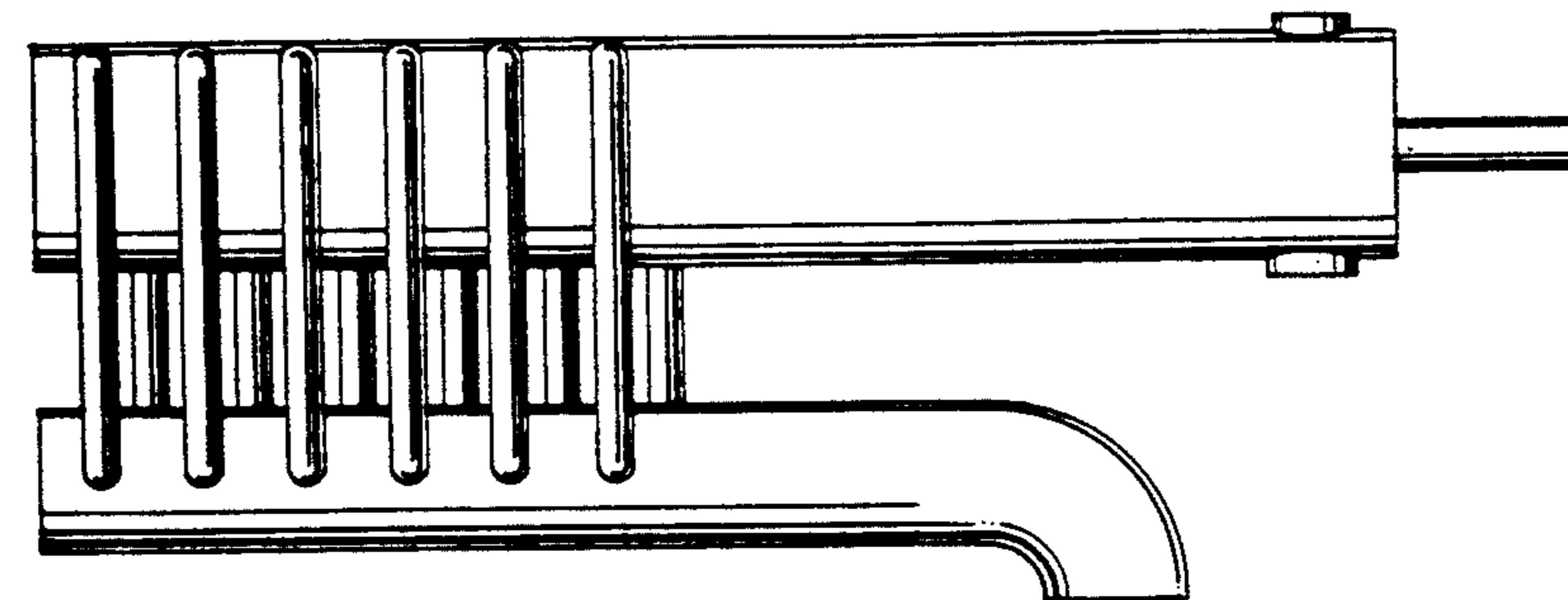

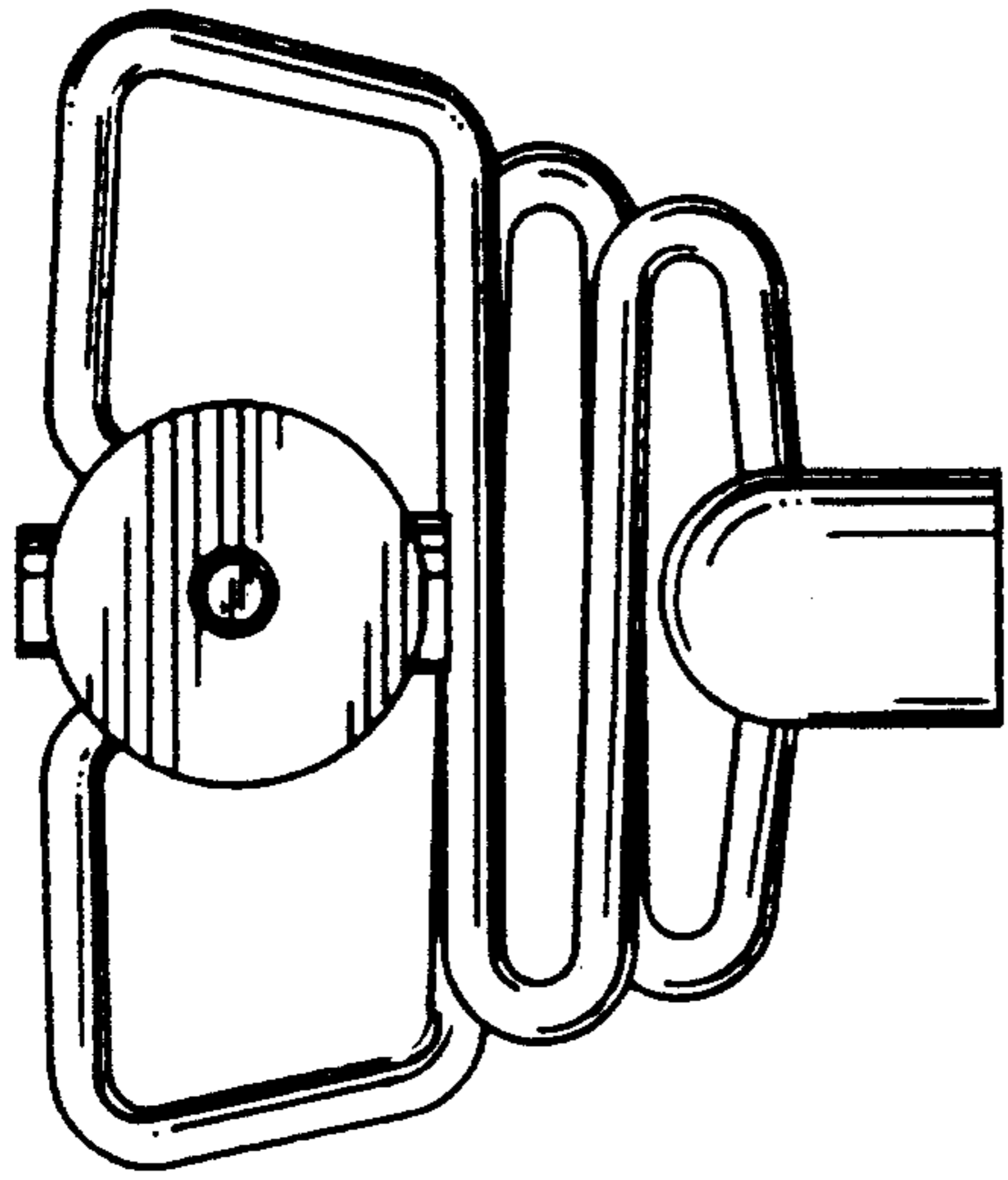

FIG. 4

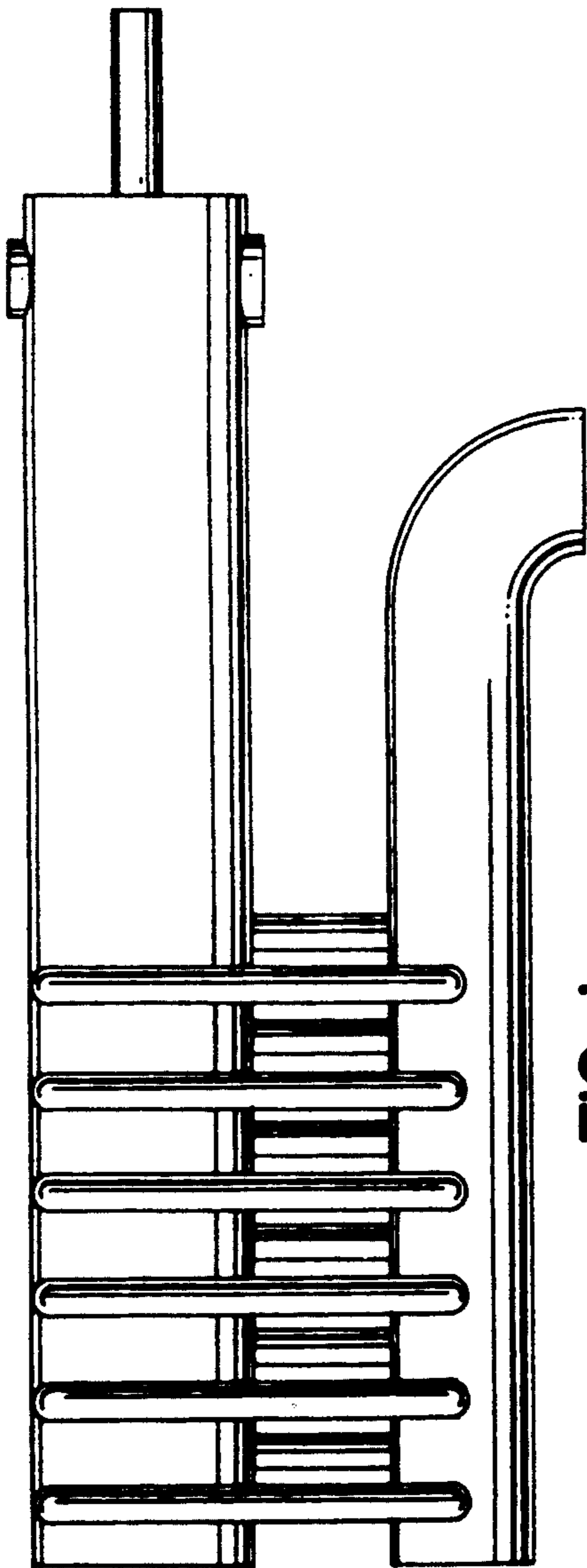

FIG. 1

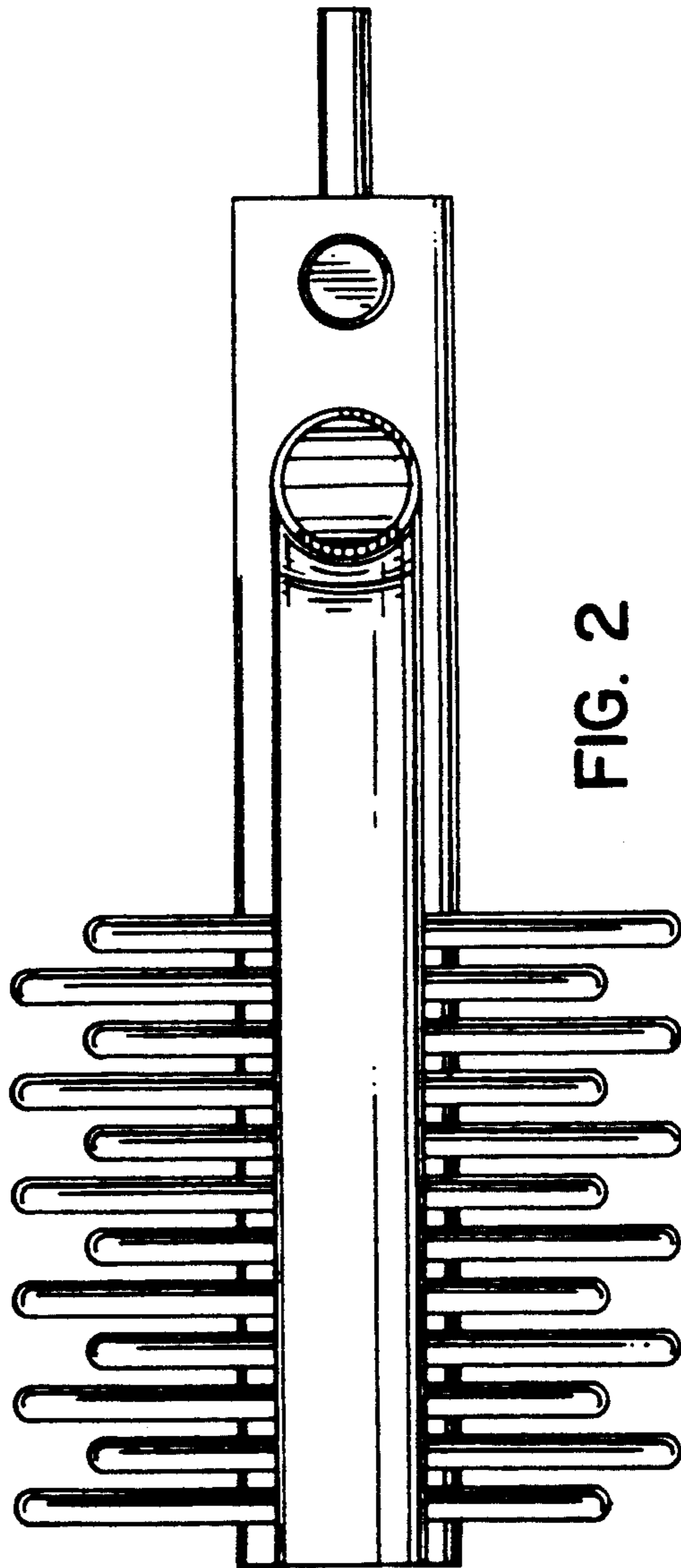

FIG. 2

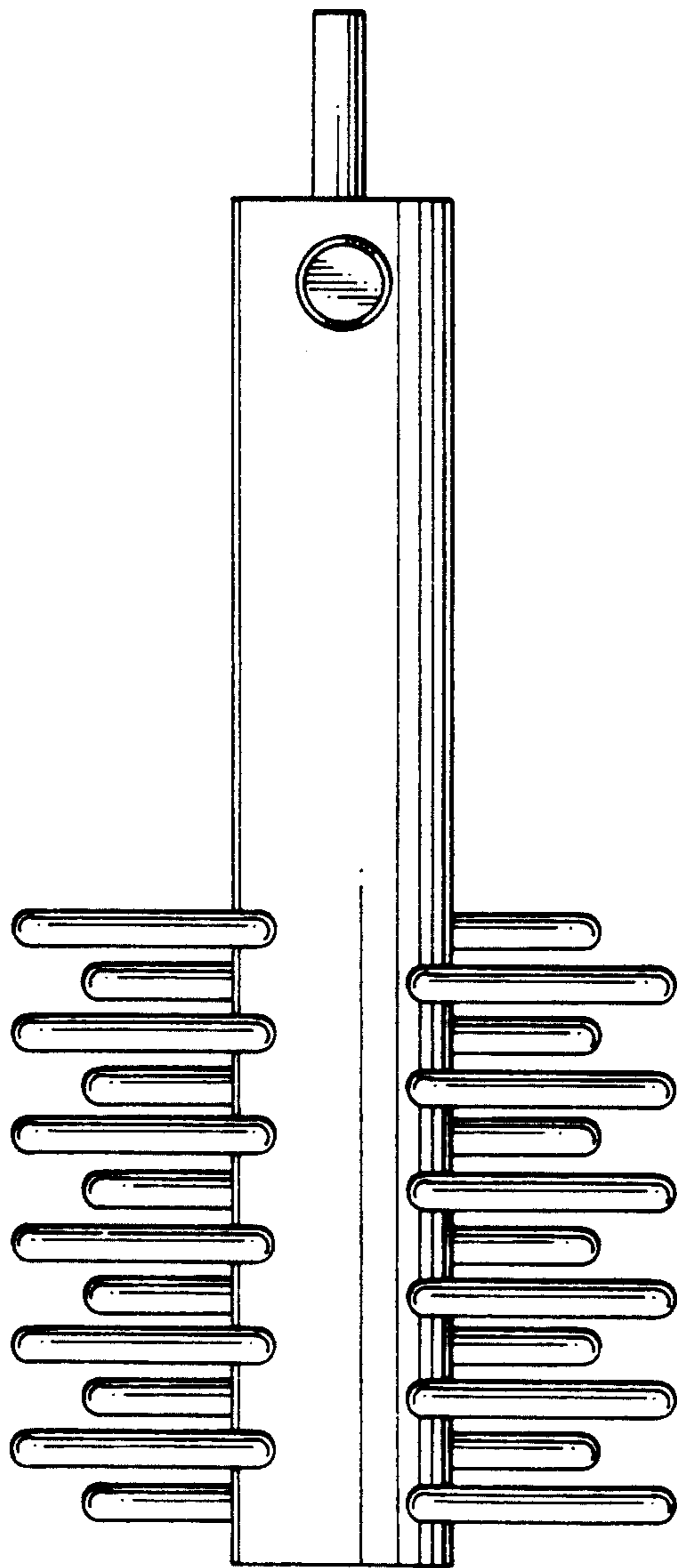

FIG. 3

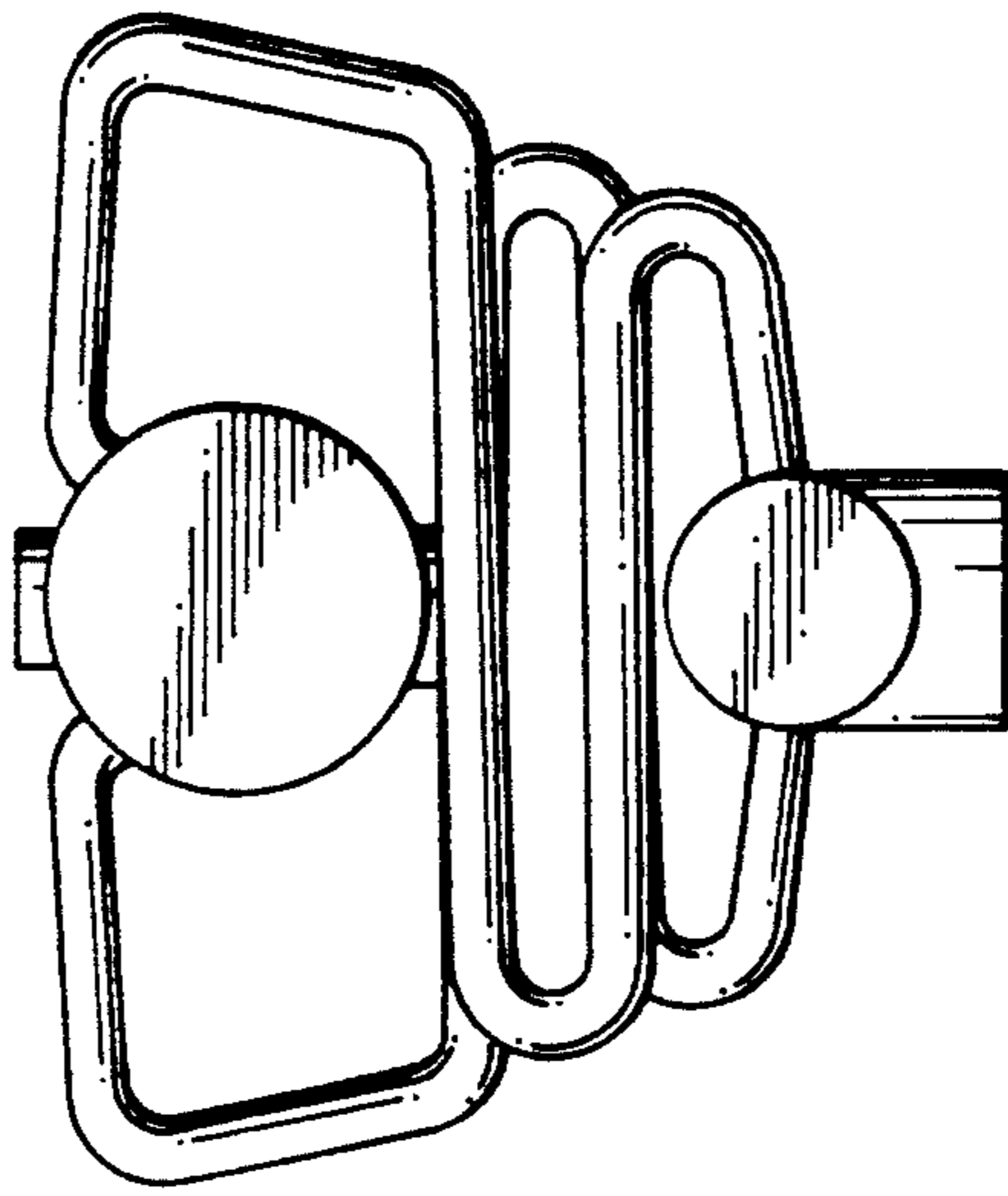

FIG. 5

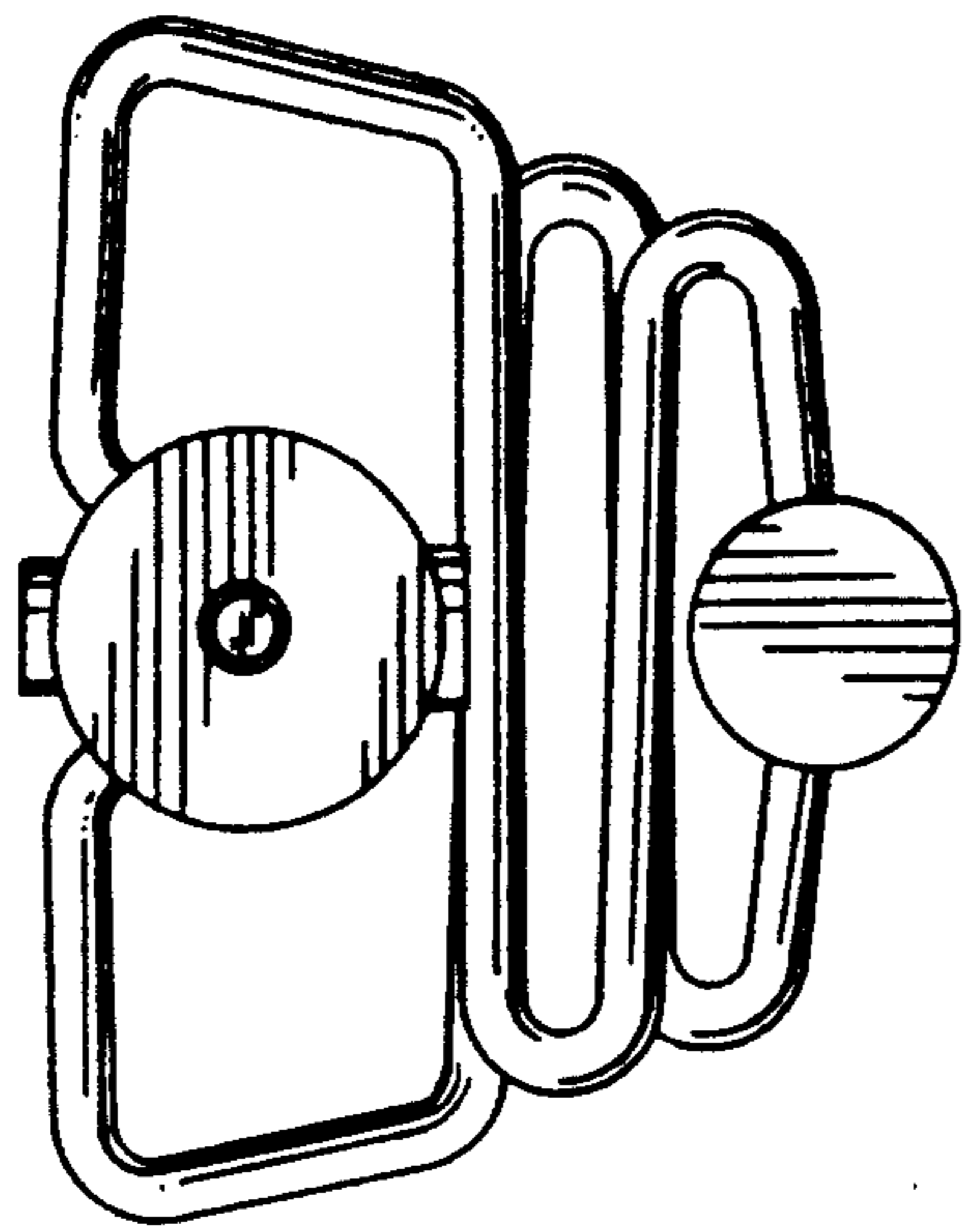

FIG. 9

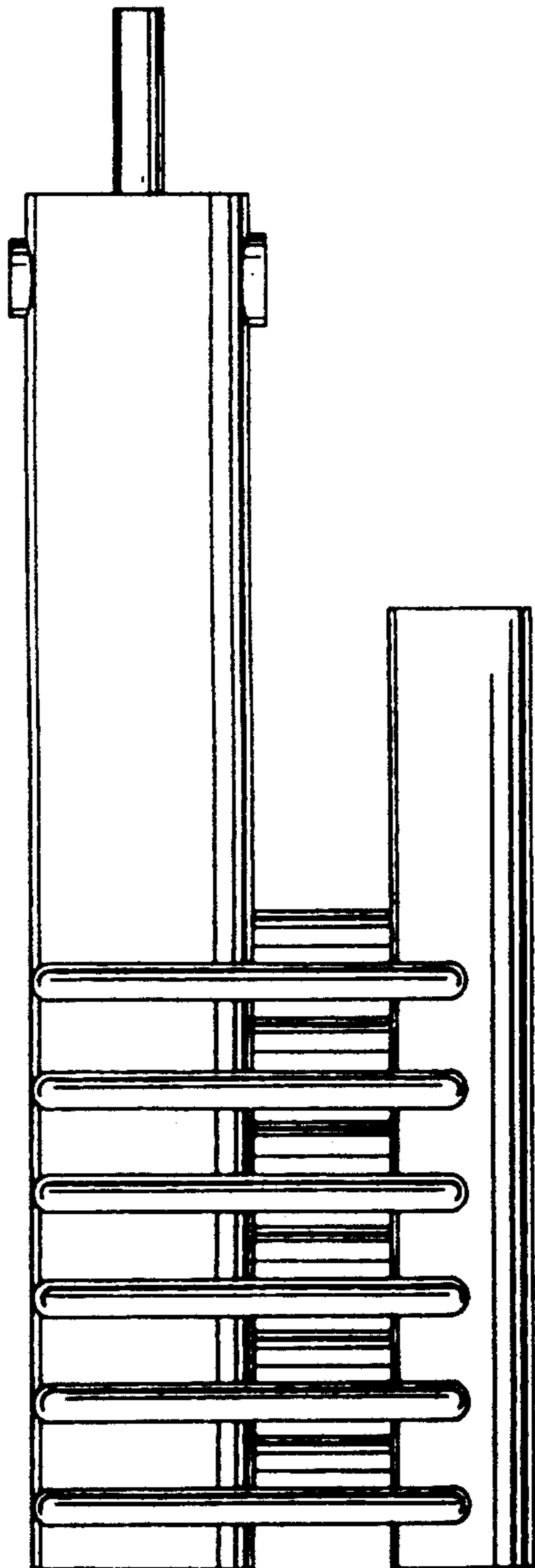

FIG. 6

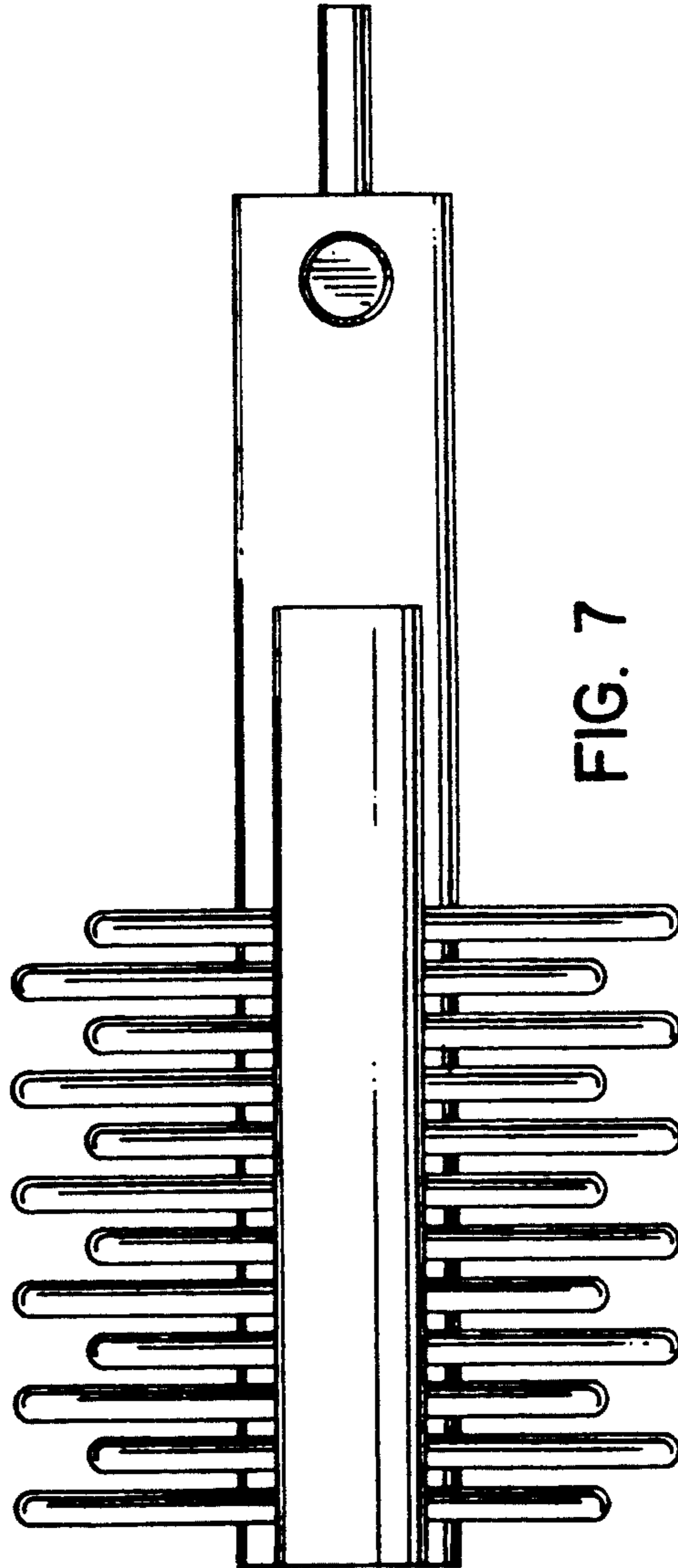

FIG. 7

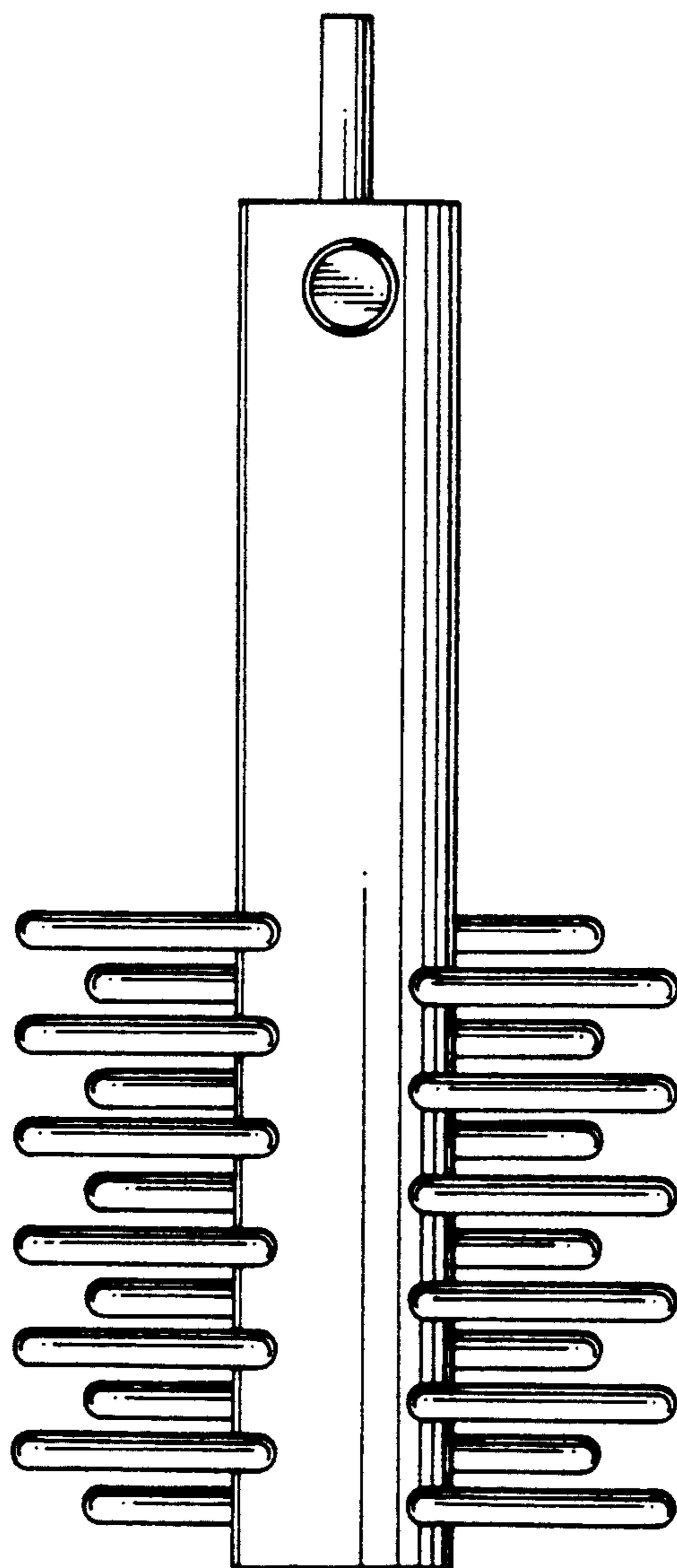

FIG. 8

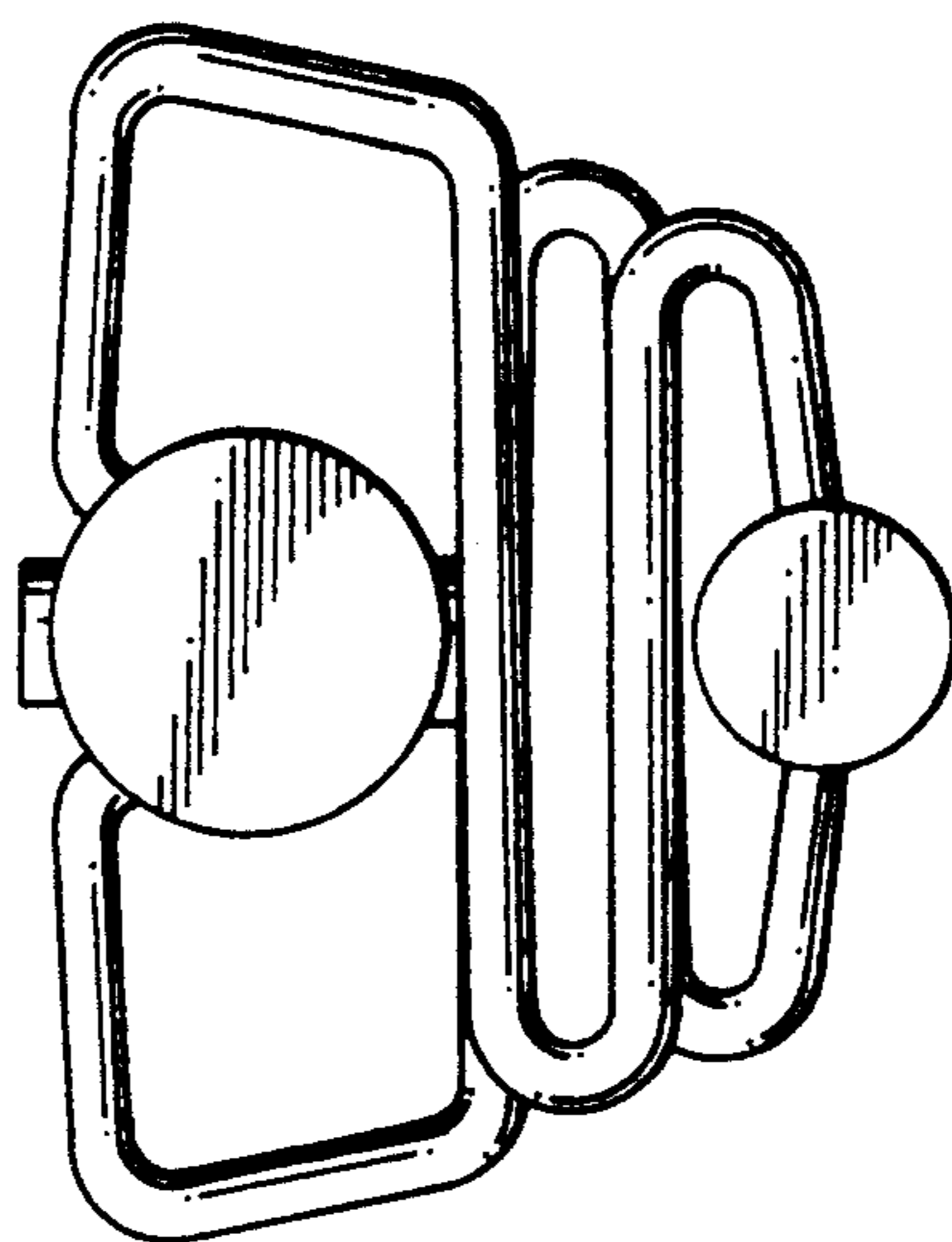

FIG. 10