



US00D345174S

United States Patent [19]

[11] Patent Number: **Des. 345,174**

Attias

[45] Date of Patent: **** Mar. 15, 1994**

[54] **NECK OF A MUSICAL INSTRUMENT**

Primary Examiner—Bernard Ansher
Assistant Examiner—Adir Aronovich

[76] Inventor: **James Attias**, 19470 NW. 59th Ave.,
Miami, Fla. 33015

[57] **CLAIM**

[**] Term: **14 Years**

The ornamental design for a neck of a musical instrument, as shown and described.

[21] Appl. No.: **645,667**

DESCRIPTION

[22] Filed: **Jan. 17, 1991**

[52] U.S. Cl. **D17/20**

[58] Field of Search 84/290-293,
84/267; D17/14, 15, 18-20

FIG. 1 is a bottom isometric view of a neck of a musical instrument showing my new design;
FIG. 2 is a bottom plan view thereof;
FIG. 3 is a side cross-sectional view of the neck of FIG. 2 taken through the line 3—3 thereof;
FIG. 4 is a top plan view of the neck of a musical instrument;
FIG. 5 is an end elevational view taken from the bottom thereof;
FIG. 6 is an end elevational view taken from the top thereof; and,
FIG. 7 is a cross sectional view thereof, taken along the line 7—7 of FIG. 1.

[56] **References Cited**

U.S. PATENT DOCUMENTS

D. 102,164	12/1936	Harlin	D17/20
2,100,249	11/1937	Hart	84/293
2,460,943	2/1949	Nelson	84/293
3,901,119	8/1975	Siminoff	84/293
4,759,250	7/1988	Lieber	84/293

FOREIGN PATENT DOCUMENTS

575158 4/1933 Fed. Rep. of Germany .

The broken line showing of a guitar body and a fret board is for illustrative purposes only and forms no part of the claimed design.

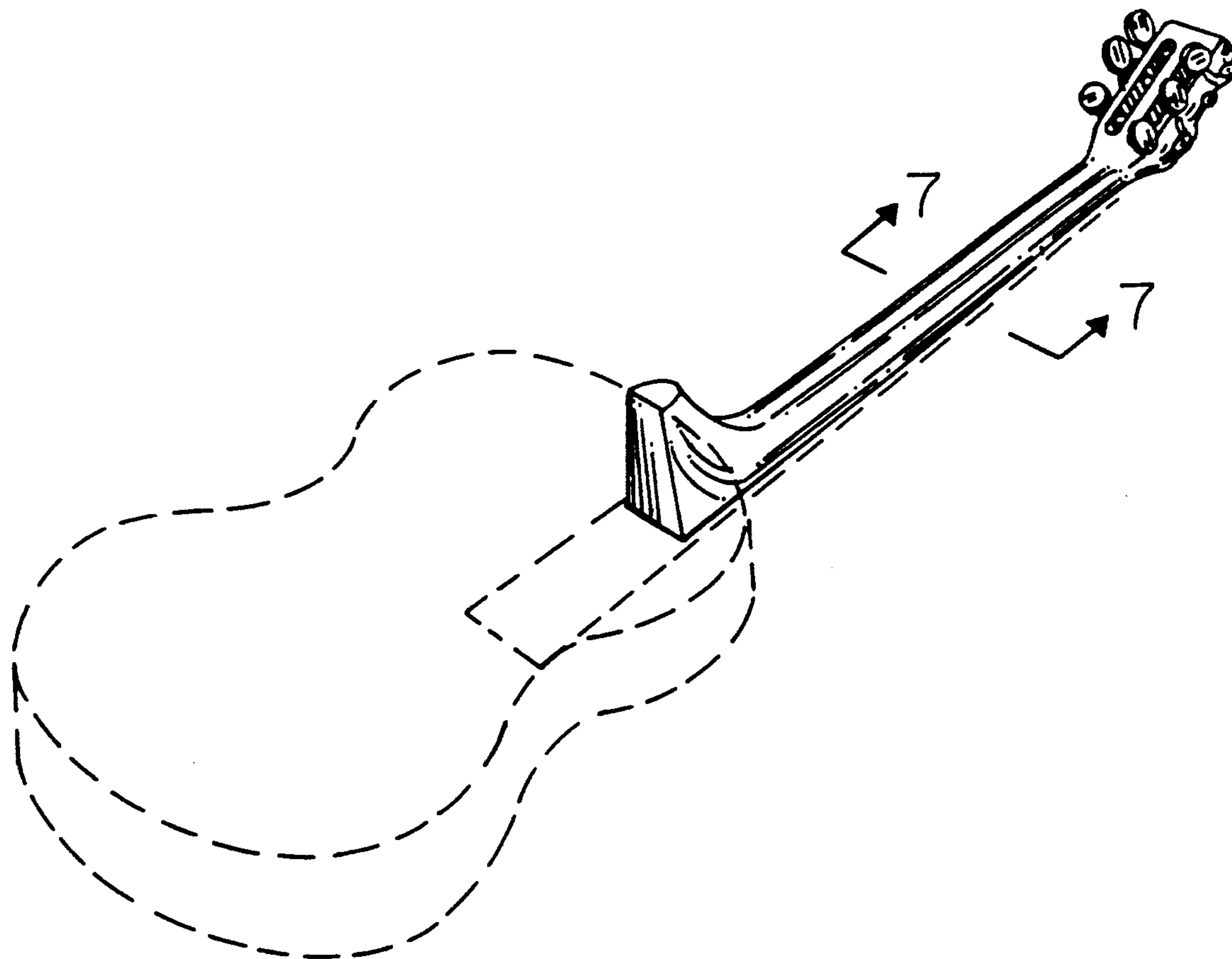

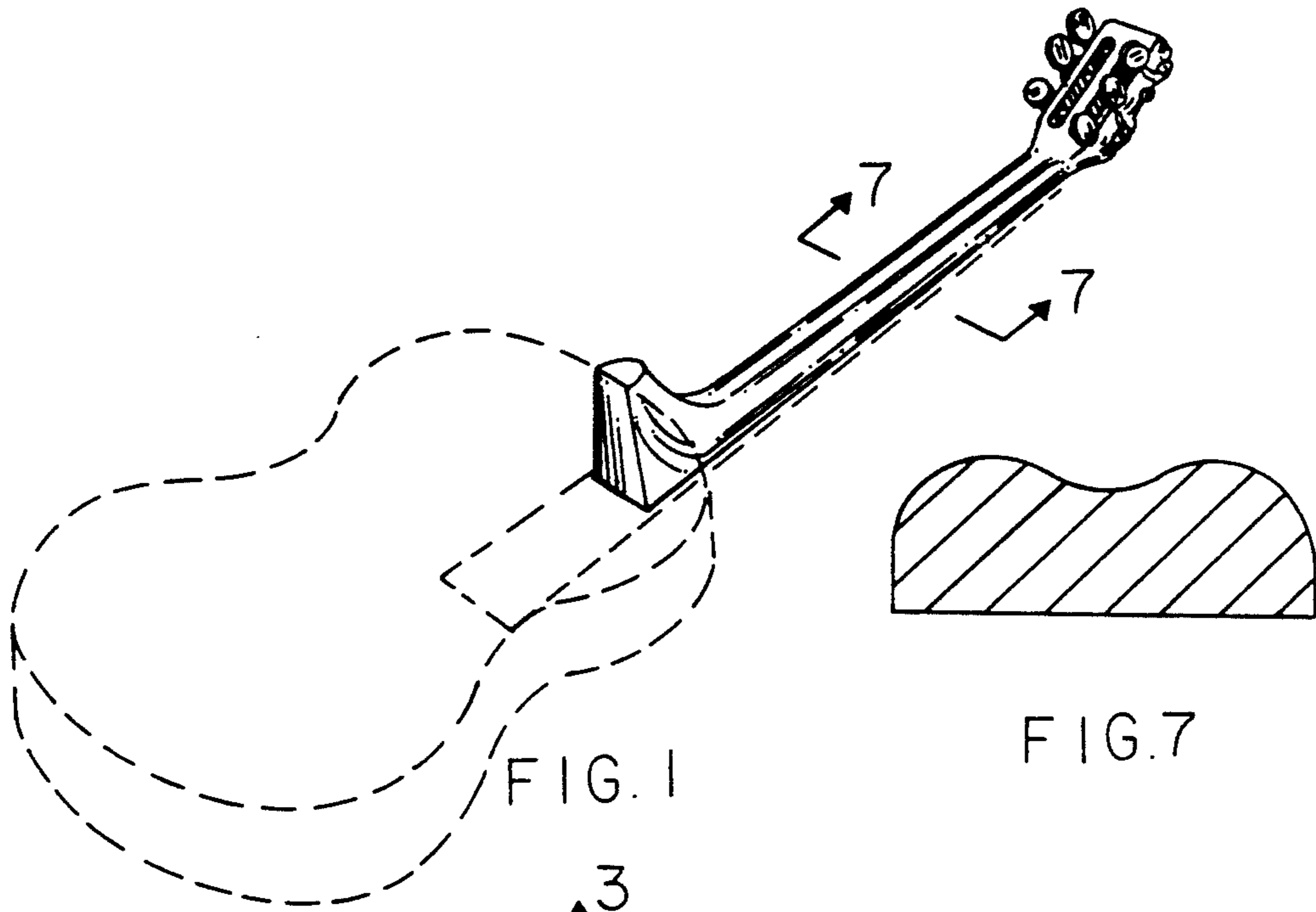

FIG. 7

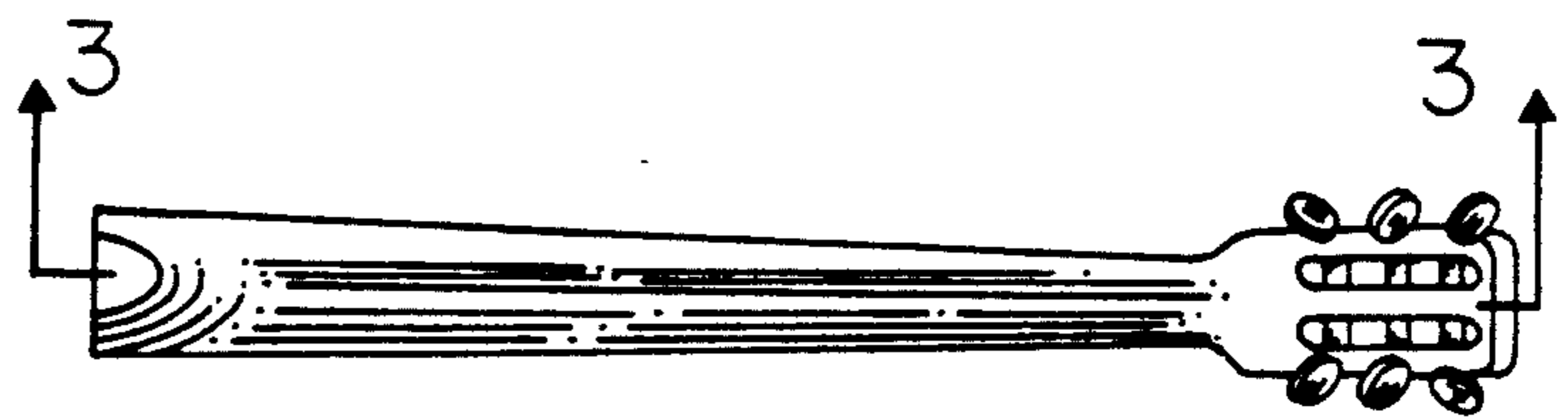

FIG. 5

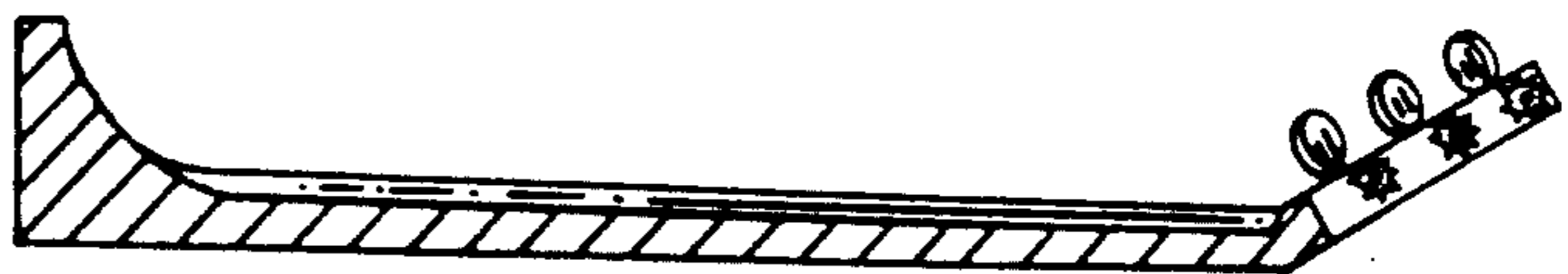

FIG. 3



FIG. 6

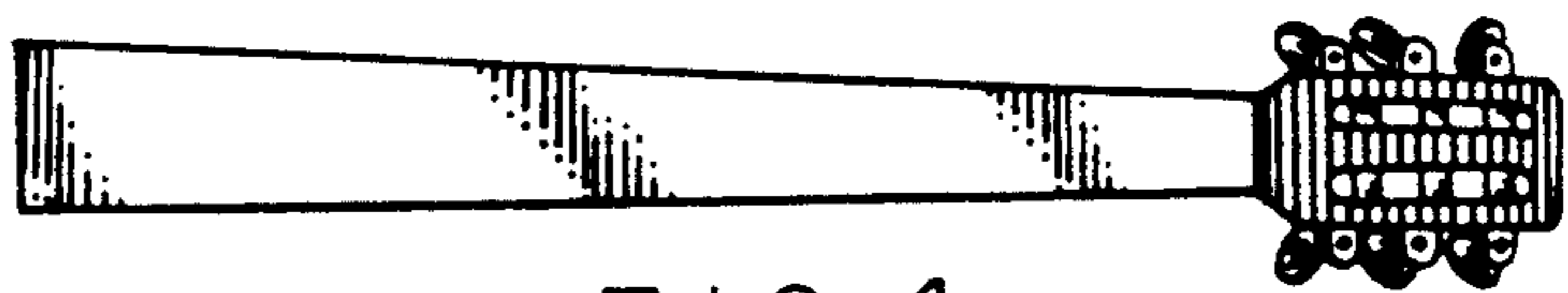

FIG. 4