



US00D345124S

United States Patent [19]

[11] Patent Number: **Des. 345,124**

Lewellen et al.

[45] Date of Patent: **** Mar. 15, 1994**

[54] **TRUCK BODY REAR END UNIT**

[75] Inventors: **Richard Lewellen; George Kalis, Jr.; Robert M. Lapsley**, all of Wooster, Ohio

[73] Assignee: **The Scott Fetzer Company**, Westlake, Ohio

[**] Term: **14 Years**

[21] Appl. No.: **916,174**

[22] Filed: **Jul. 17, 1992**

[52] U.S. Cl. **D12/98**

[58] Field of Search 296/24.1, 183; 293/102, 293/117; D12/96, 98, 169, 196

[56] **References Cited**

U.S. PATENT DOCUMENTS

D. 157,321	2/1950	Barden	D12/169
D. 190,416	5/1961	Powers	D12/96
4,126,349	11/1978	Nelson et al.	296/24.1
4,685,695	8/1987	Le Vee	296/24.1

Primary Examiner—James M. Gandy
Attorney, Agent, or Firm—Watts, Hoffmann, Fisher & Heinke

[57] **CLAIM**

The ornamental design for a truck body rear end unit, as shown and described.

DESCRIPTION

FIG. 1 is a perspective view of a truck body rear end unit showing our new design; FIG. 2 is a greatly enlarged left side elevational view of the truck body rear end unit, it being understood that the right side is a mirror image thereof; FIG. 3 is a rear elevational view of the truck body rear end unit thereof; FIG. 4 is a front elevational view thereof; FIG. 5 is an enlarged top plan view thereof; and, FIG. 6 is an enlarged bottom plan view thereof. The broken line showing of environmental structure in FIGS. 1, 2, 3, 5, and 6 of the drawings is for illustrative purposes only and forms no part of the claimed design.

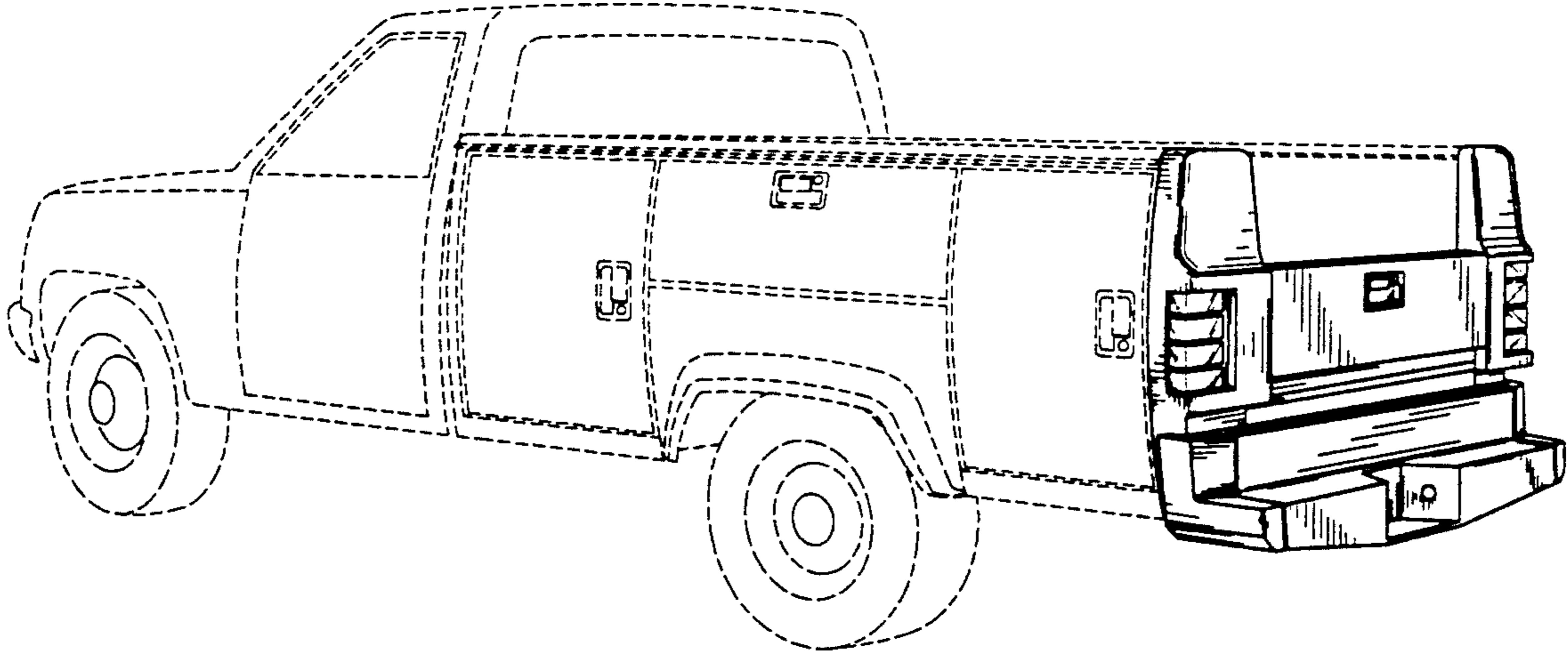

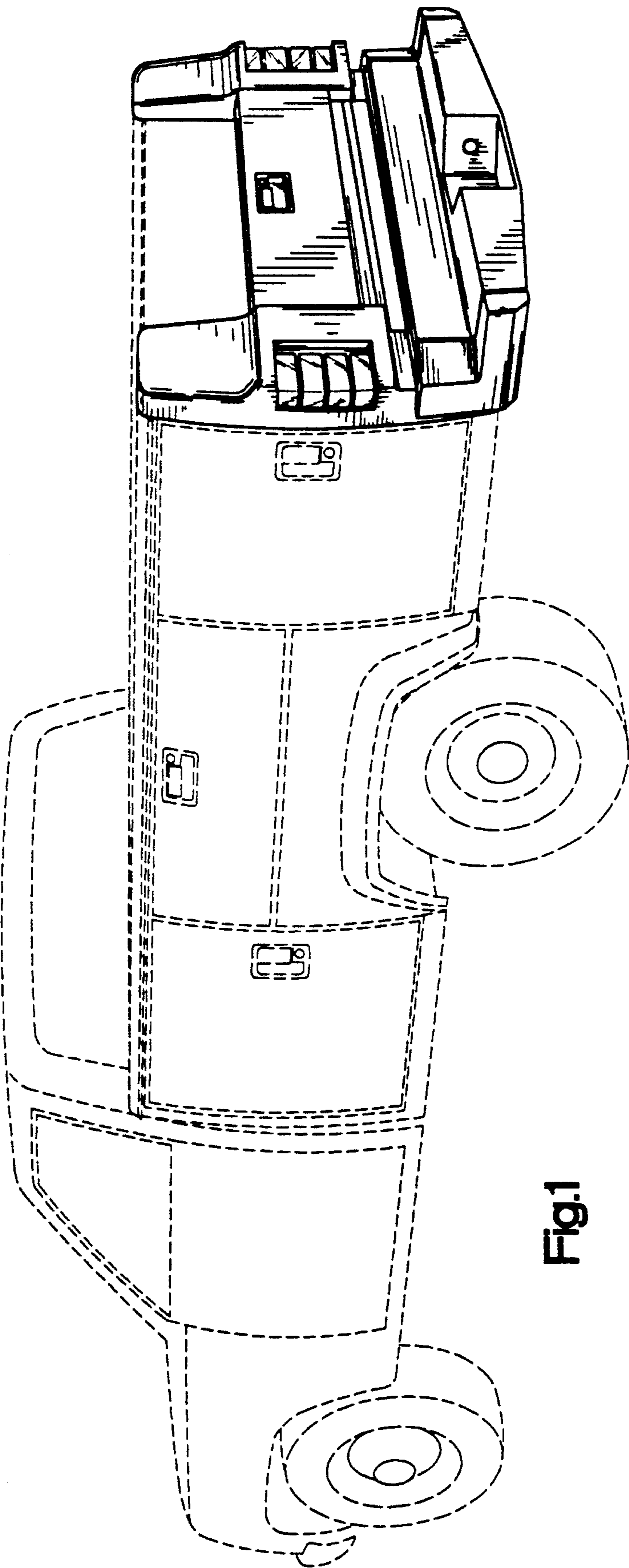

Fig.1

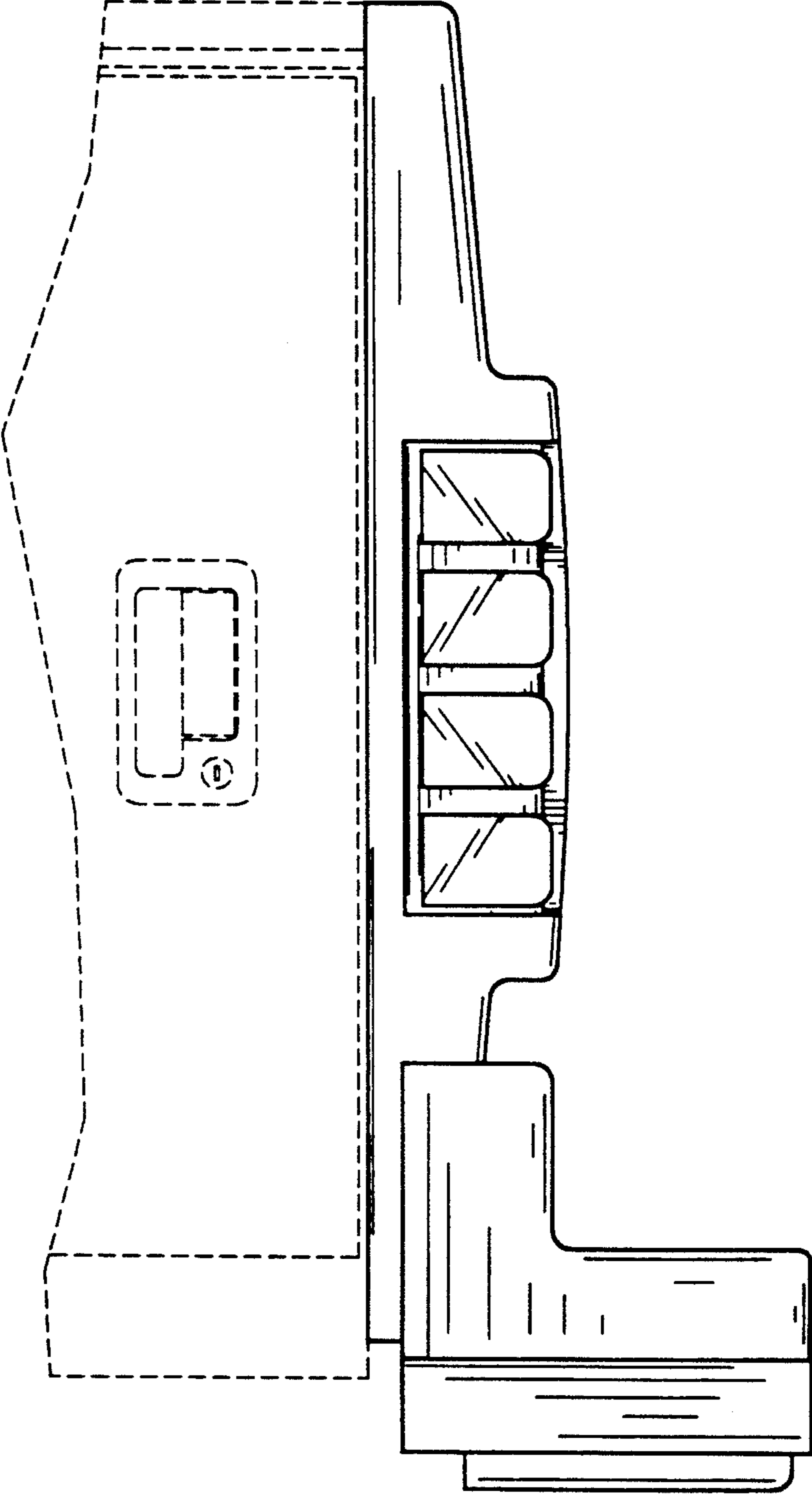

Fig.2

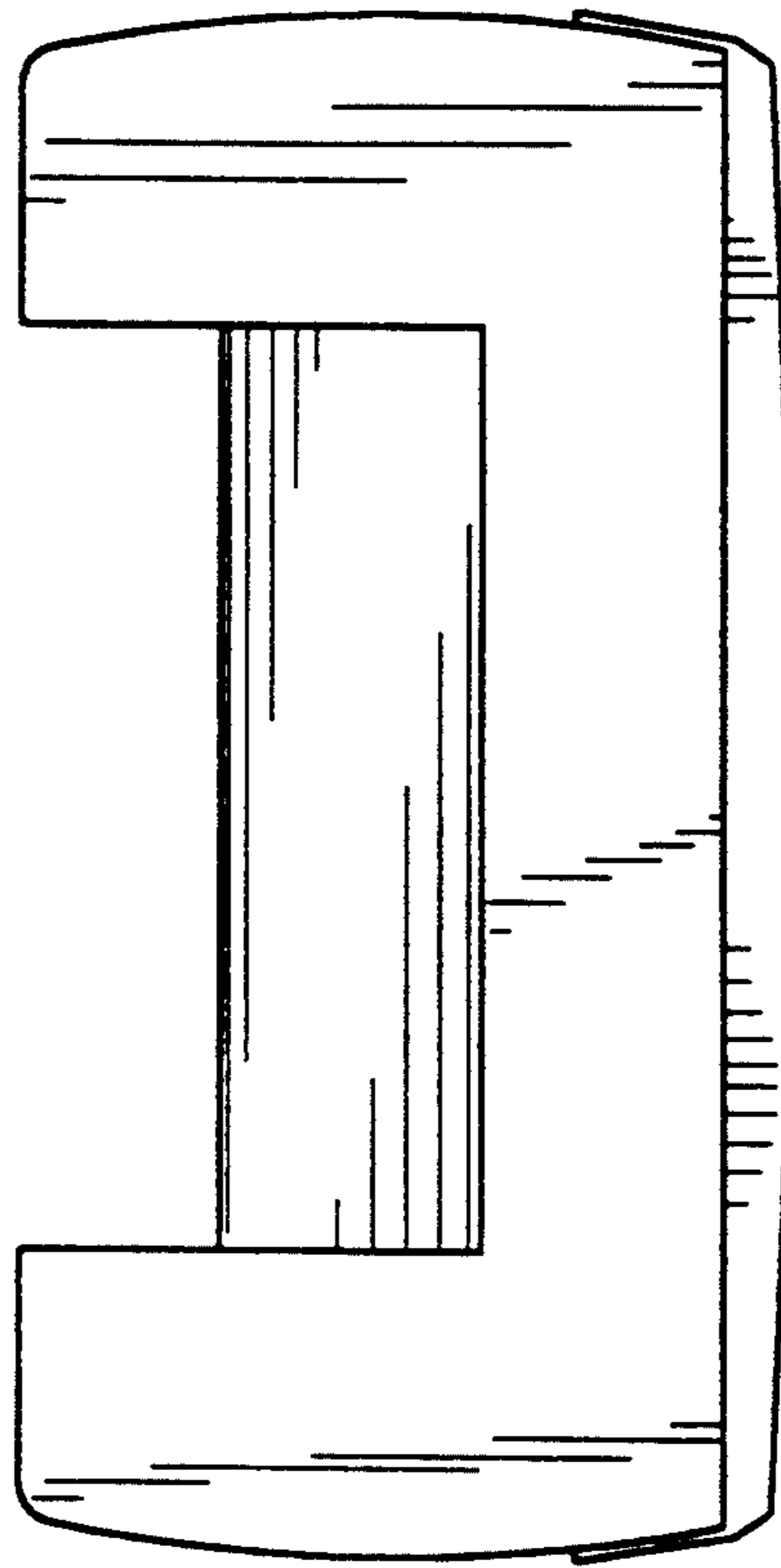

Fig.4

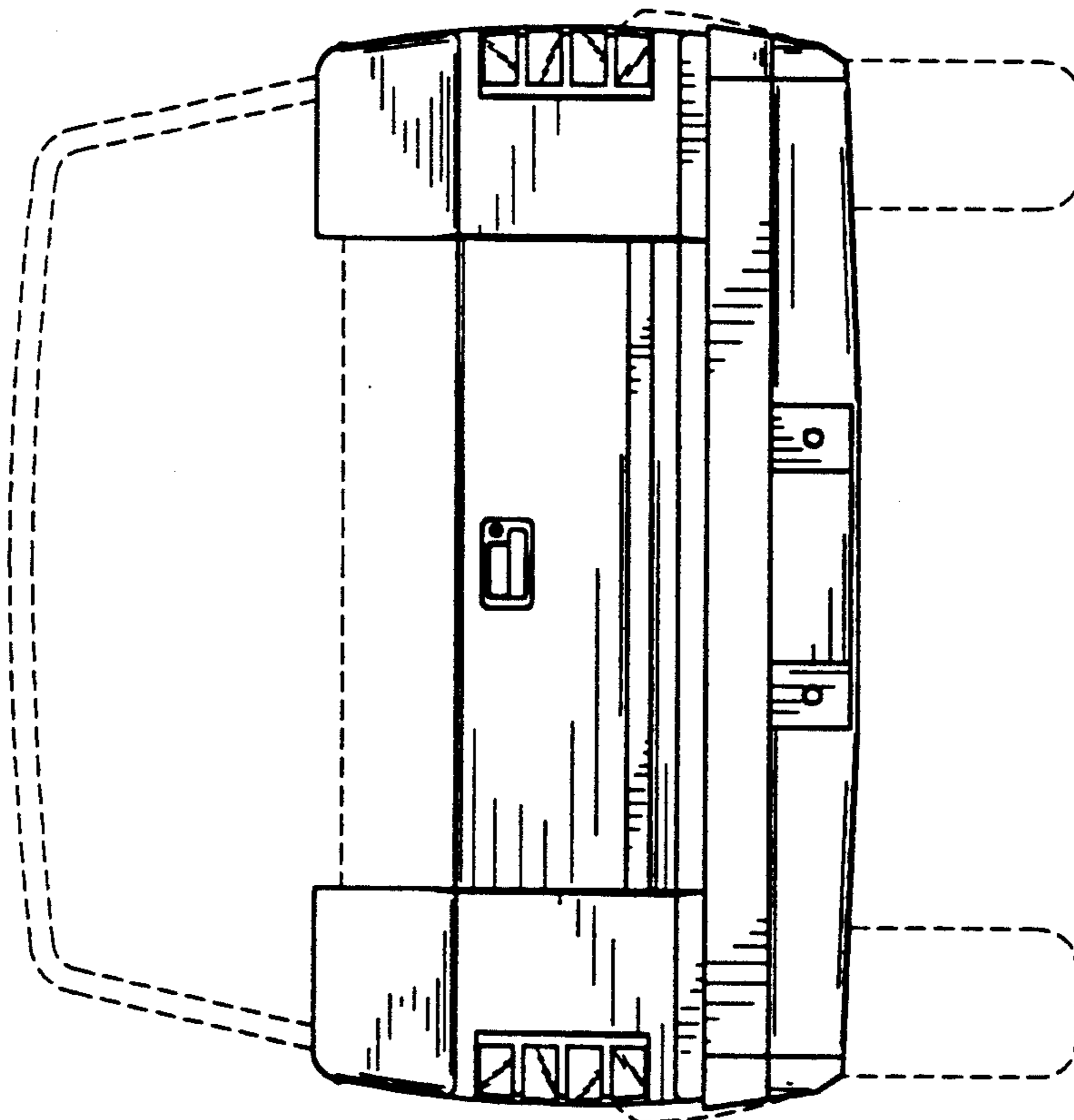

Fig.3

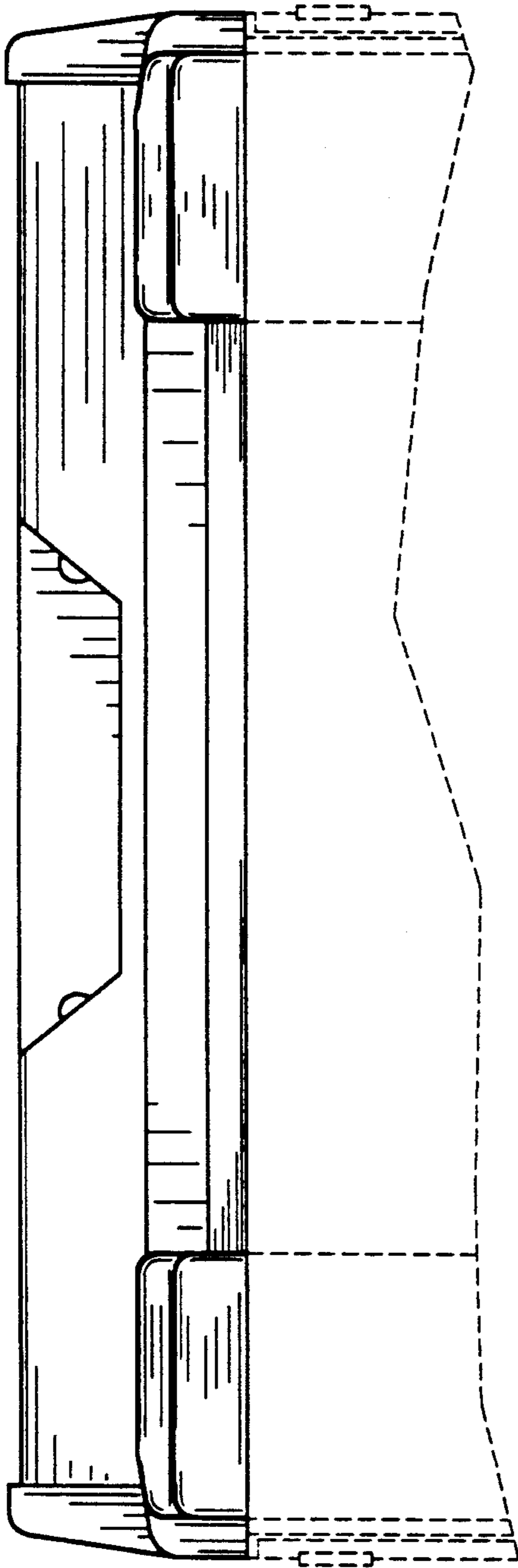

Fig.5

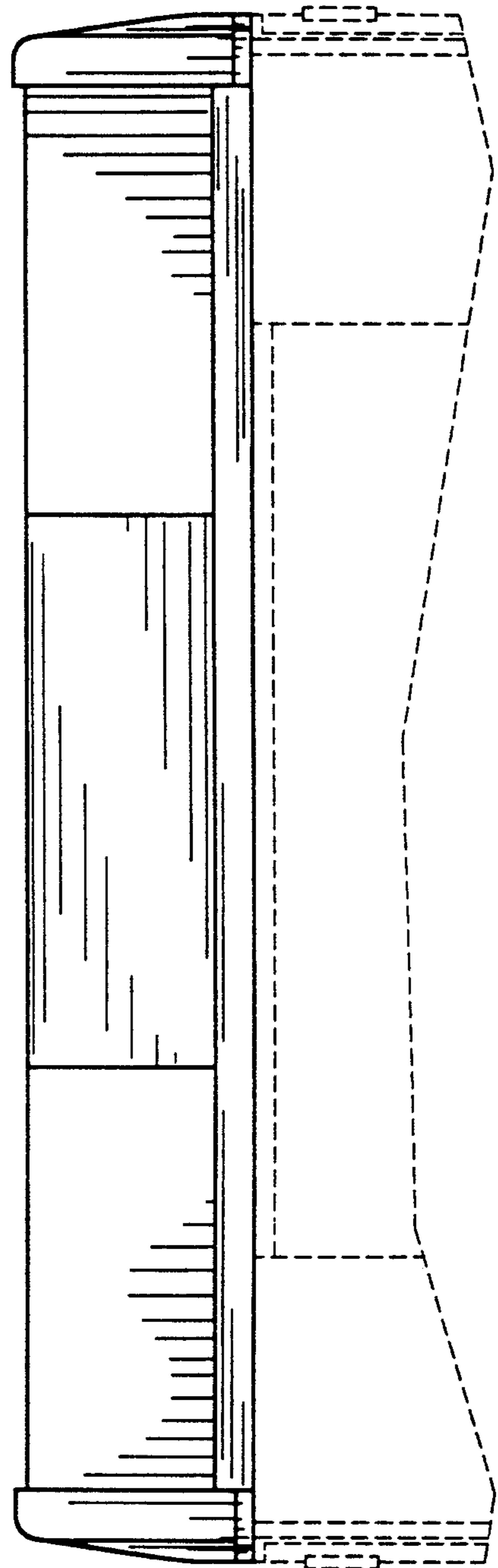

Fig.6