



US00D344959S

United States Patent [19]

[11] Patent Number: **Des. 344,959**

Patterson et al.

[45] Date of Patent: **** Mar. 8, 1994**

[54] **VEHICLE REAR TRIM**

[75] Inventors: **Jon M. Patterson**, Wauwatosa, Wis.;
James H. Weitz, Ridgewood, N.J.;
Daniel R. Nickles, Hewitt, N.J.;
William E. Crookes, Waldwick, N.J.

[73] Assignee: **Deere & Company**, Moline, Ill.

[**] Term: **14 Years**

[21] Appl. No.: **830,168**

[22] Filed: **Jan. 31, 1992**

[52] U.S. Cl. **D15/17**

[58] Field of Search 56/13.4, 16.7, 17.5,
56/202, 255, 294, 320.1, 320.2; D15/14-18, 33

[56] **References Cited**

U.S. PATENT DOCUMENTS

D. 213,124	1/1969	Koeber et al.	D15/15
D. 248,655	7/1978	Klein	D15/15
D. 293,683	1/1988	Mizushima et al.	D15/15
D. 327,484	6/1992	Flenniken et al.	D15/17

OTHER PUBLICATIONS

Deere & Company, *John Deere Riding Mowers*, 8 pages, 1991, published in U.S.A.

Deere & Company, *John Deere F700 Series Front Mowers*, 4 pages, 1992, published in U.S.A.

Deere & Company, *John Deere F500 Series Front Mowers*, 8 pages, 1991, published in U.S.A.

Deere & Company, *John Deere Front Mowers F1145/F900 Series*, 8 pages, 1992, published in U.S.A.

Kubota Tractor Corporation, *Kubota Lawn Tractors T1400H/T1600H/T1700HX*, 16 pages, Feb. 1991, published in U.S.A.

American Honda Motor Co. Inc., *Honda Utility Tractor*, 6 pages, 1987, published in U.S.A.

Ford New Holland, Inc., *Ford 8-to 18-hp Lawn, Yard and Garden Tractors, Riding Mowers*, 20 pages, 1989, published in U.S.A.

Ariens Company, *Ariens Tractors*, 16 pages, 1987, published in U.S.A.

The Murray Ohio Manufacturing Company, *The Clear Cut Choice. 1987*, 40 pages, 1987, published in U.S.A.

Primary Examiner—Bernard Ansher

Assistant Examiner—Sandra Morris

[57] **CLAIM**

The ornamental design for a vehicle rear trim, as shown and described.

DESCRIPTION

FIG. 1 is a left side perspective view of a vehicle rear trim, showing our new design, the broken line showing a tractor is for illustrative purposes only and forms no part of the claimed design;

FIG. 2 is a rear elevational view thereof;

FIG. 3 is a left side elevational view thereof; and,

FIG. 4 is a right side elevational view thereof.

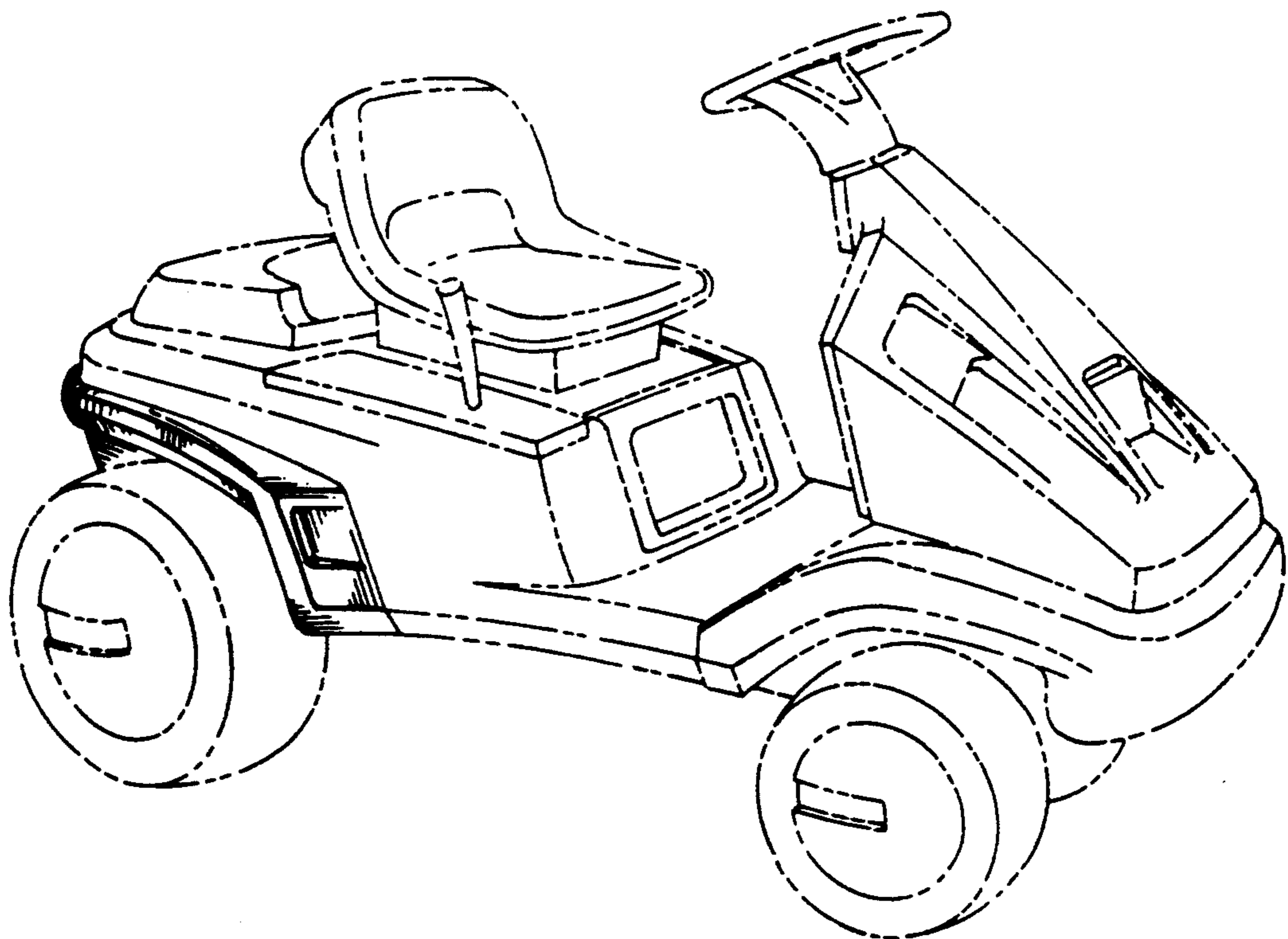

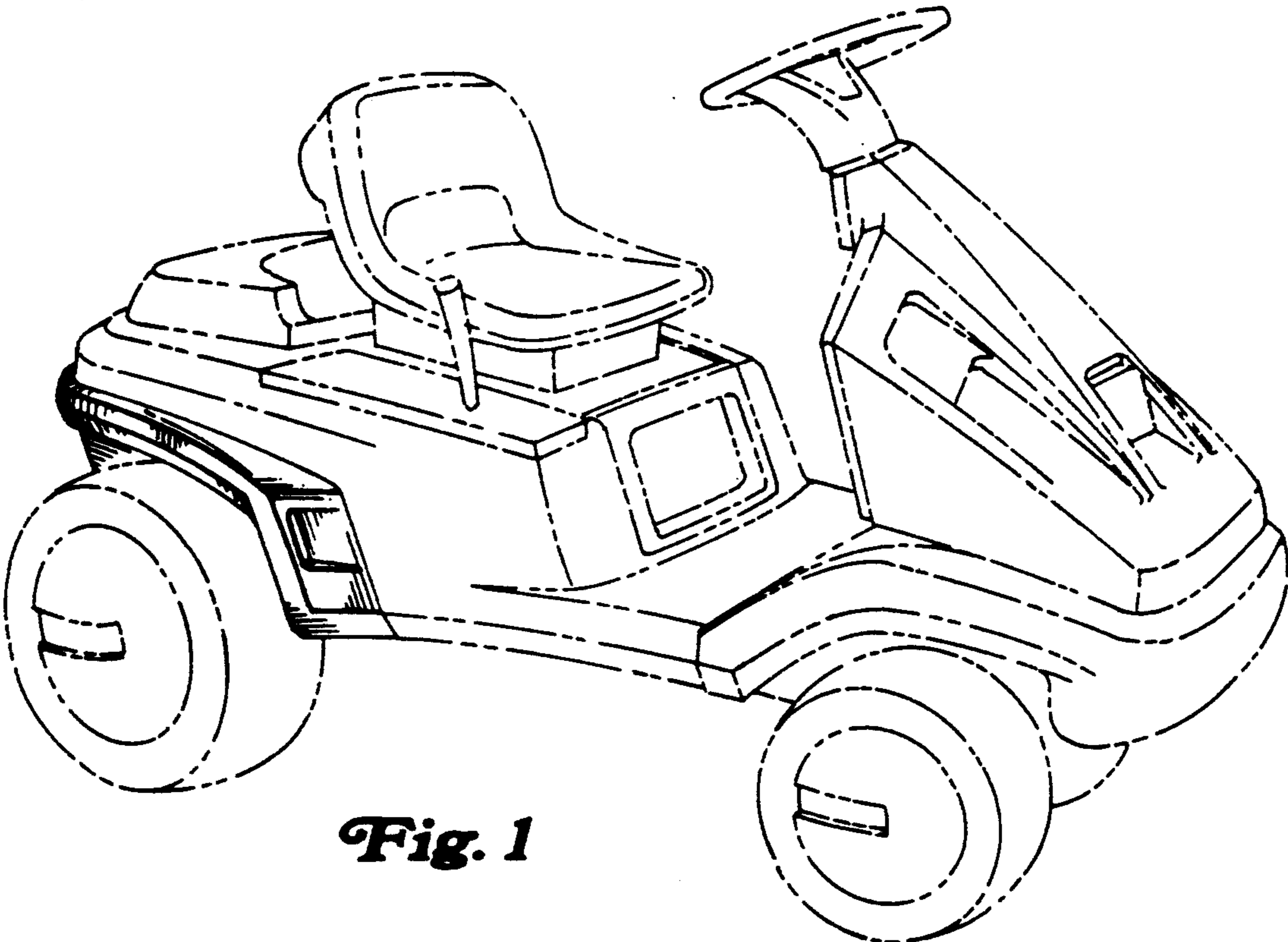

Fig. 1

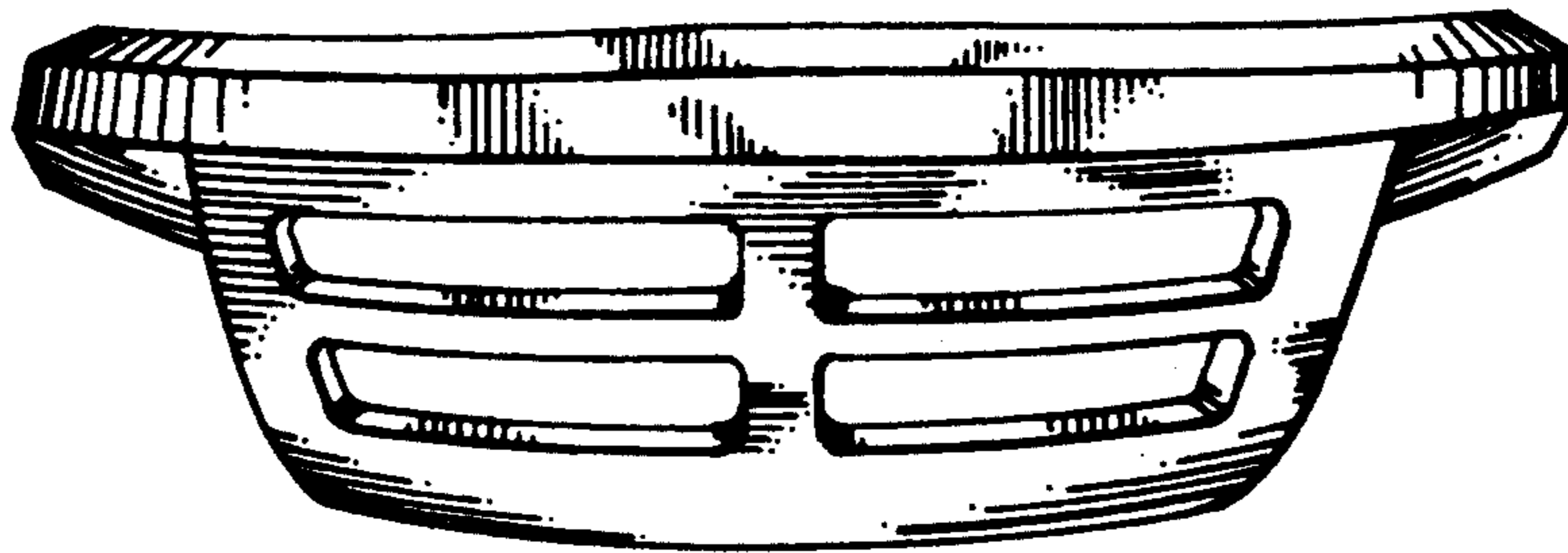

Fig. 2

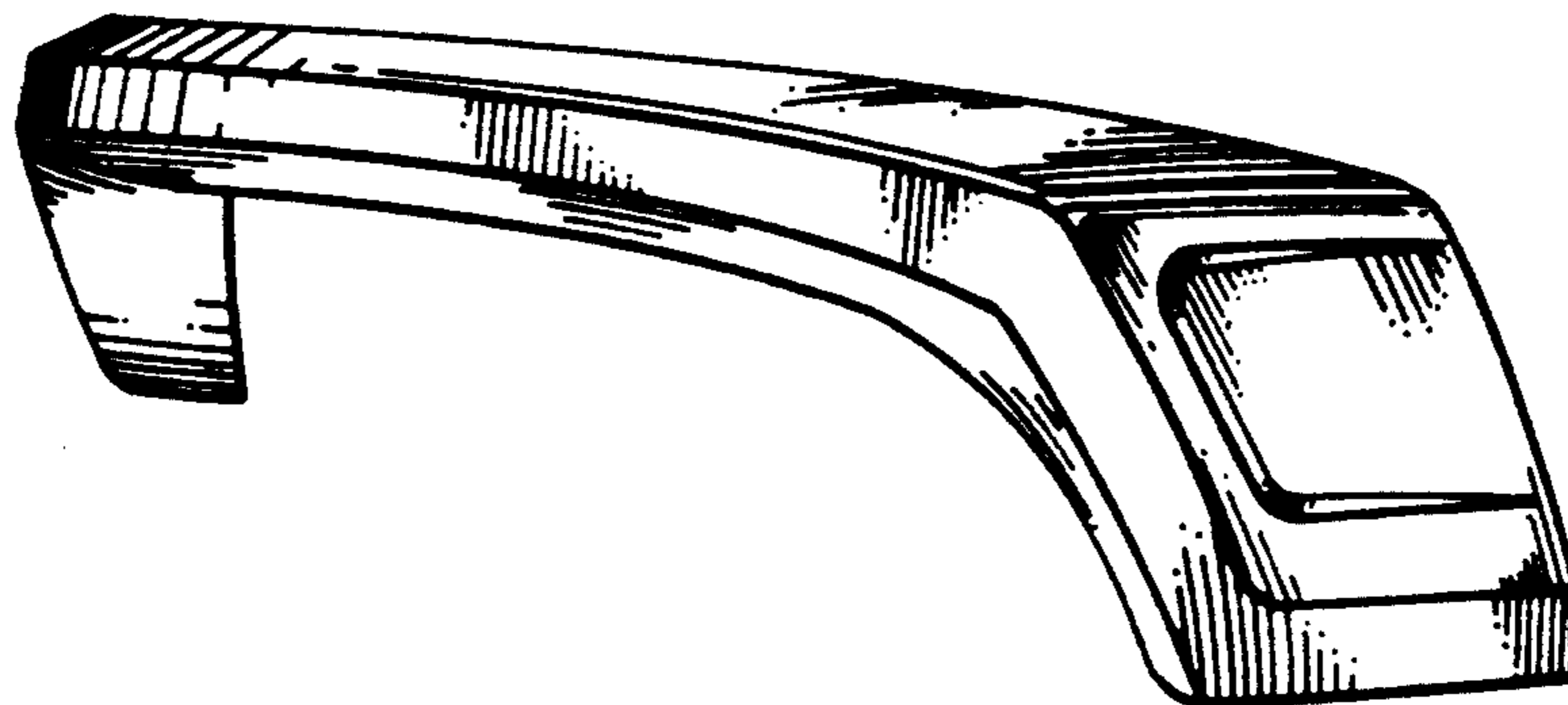

Fig. 3

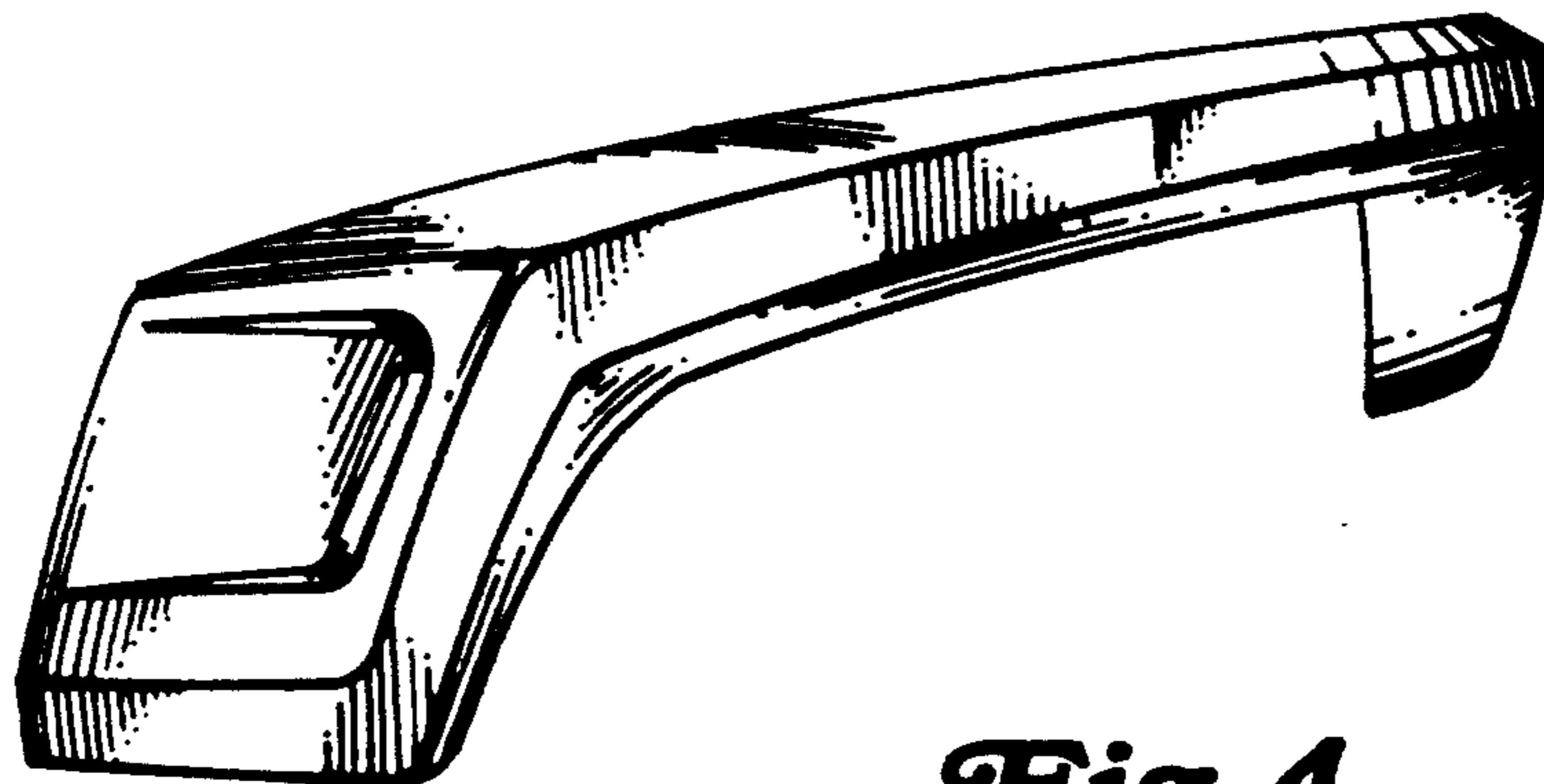

Fig. 4