



US00D344928S

United States Patent [19]

[11] Patent Number: **Des. 344,928**

Vinciarelli et al.

[45] Date of Patent: **** Mar. 8, 1994**

[54] **PACKAGE FOR DC-DC POWER CONVERTER OR RELATED CIRCUITRY**

[75] Inventors: **Patrizio Vinciarelli, Boston; Fred M. Finnemore, North Reading, both of Mass.**

[73] Assignee: **VLT Corporation, San Antonio, Tex.**

[**] Term: **14 Years**

[21] Appl. No.: **916,350**

[22] Filed: **Jul. 17, 1992**

Related U.S. Application Data

[63] Continuation-in-part of Ser. No. 809,412, Dec. 17, 1991.

[52] U.S. Cl. **D13/110**

[58] Field of Search **361/386, 388, 392; 336/90, 92, 200; 363/15, 95; 307/150, 151; 174/52.1, 52.2; D13/110, 123, 124**

[56] **References Cited**

U.S. PATENT DOCUMENTS

- D. 224,971 10/1972 Projain et al. D13/124
- D. 263,465 3/1982 Fathi D13/110
- D. 297,928 10/1988 Harpley et al. D13/110
- D. 328,057 7/1992 Prager et al. D13/110
- 2,427,111 9/1947 Tolmie 175/393
- 2,876,424 3/1959 Stiler 336/92 X
- 3,089,070 5/1963 Ralph 320/2
- 4,012,672 3/1977 Douglass et al. 336/92 X
- 4,205,291 3/1980 Flentge 336/92
- 4,455,545 6/1984 Shelly 336/200
- 4,487,999 12/1984 Baird et al. 174/52
- 4,656,450 4/1987 Jarosz et al. 336/92 X

OTHER PUBLICATIONS

Electronic Design, vol. 23, No. 11, May 24, 1975; DC/DC Converters.

Powercard 75 and Powercard 360 (ATC Power).

High Density, High Frequency, Modular Power Supplies (CEM).

(List continued on next page.)

Primary Examiner—Wallace R. Burke
Assistant Examiner—Joel Sincavage
Attorney, Agent, or Firm—Fish & Richardson

[57] **CLAIM**

The ornamental design for a package for DC-DC power converter or related circuitry, as shown and described.

DESCRIPTION

FIG. 1 is a perspective view of a package for a DC-DC power converter or related circuitry;
 FIG. 2 is a bottom plan view thereof;
 FIG. 3 is a side elevational view thereof, the opposite side being mirror image;
 FIG. 4 is a top plan view thereof;
 FIG. 5 is an end elevational view thereof;
 FIG. 6 is another end elevational view thereof, this end being opposite the end of FIG. 5;
 FIG. 7 through 12 illustrate another embodiment, where the descriptions of FIGS. 7 through 12 correspond to the descriptions of FIGS. 1 through 6, respectively;
 FIGS. 13 through 18 illustrate another embodiment, where the descriptions of FIGS. 13 through 18 correspond to the descriptions of FIGS. 1 through 6, respectively;
 FIGS. 19 through 24 illustrate another embodiment, where the descriptions of FIGS. 19 through 24 correspond to the descriptions of FIGS. 1 through 6, respectively;
 FIGS. 25 through 30 illustrate another embodiment, where the descriptions of FIGS. 25 through 30 correspond to the descriptions of FIGS. 1 through 6, respectively; and,
 FIGS. 31 through 36 illustrate another embodiment, where the descriptions of FIGS. 31 through 36 correspond to the descriptions of FIGS. 1 through 6, respectively.

Drawing No. 200-0500 (Tower Electronics).
 Design Data Sheet-VI-100 Series (Vicor).
 1991 Product Catalog (Vicor).

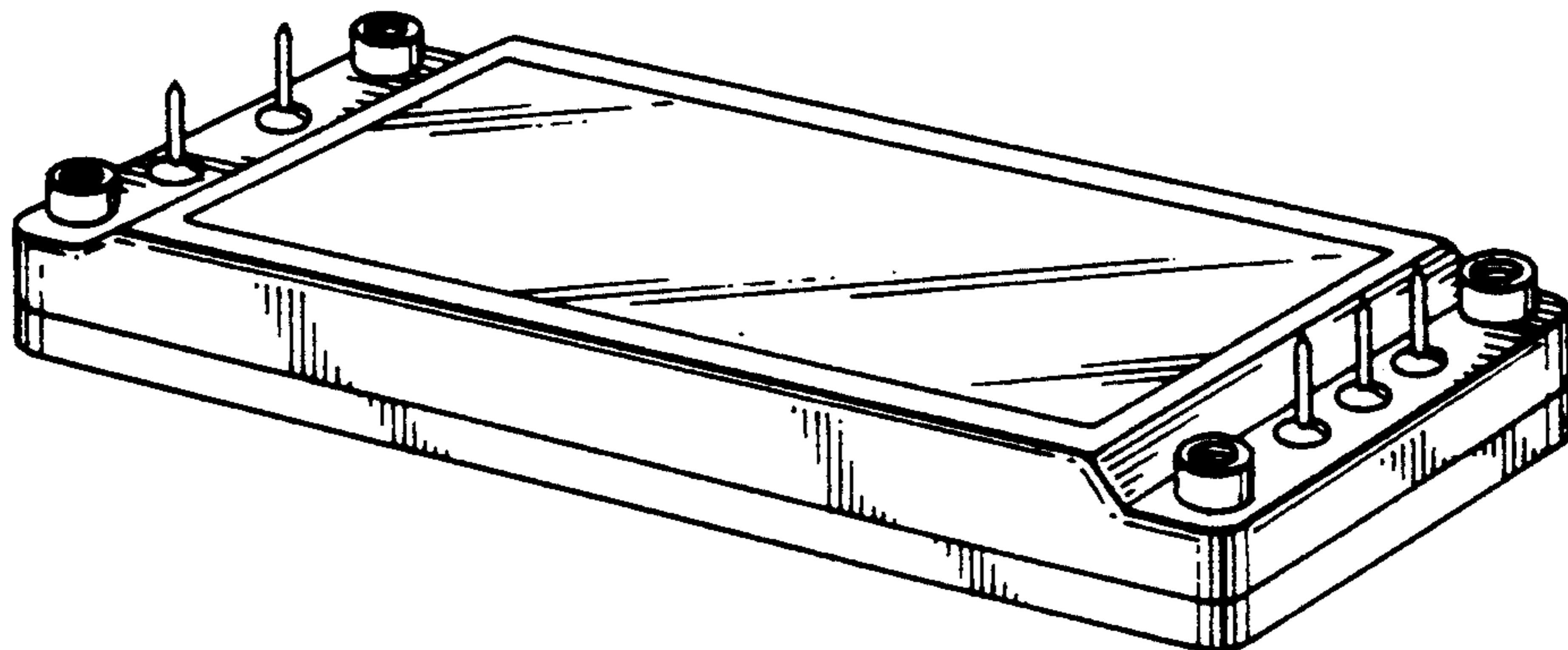

OTHER PUBLICATIONS

VI-200 Series; "Power Systems Size Reduction with High Density DC-DC Converters".

A Pair of Power Aces (Qualidyne).

RO Associates; "FullPower with No heat Sink"; 150 Watt DC-DC Converters; EDN Apr. 27, 1989.

International Power Devices; LNS Series; pp. 34, 35.

Computer Products Power Conversion Group; 1987

Computer Products Inc.; pp. 1, 154, 155, 158, 159.

International Power Devices 1988/89; 1 to 120 Watt DC/DC Converters; pp. 44, 45, 50, 51.

LAMBDA 89; Supply and Power Converter Catalog, 1989.

Outline Drawing; Miniature Module (Vicor Drawing No. 03550).

Baseplate; STD Product (ATC Power Systems Drawing No. 4612).

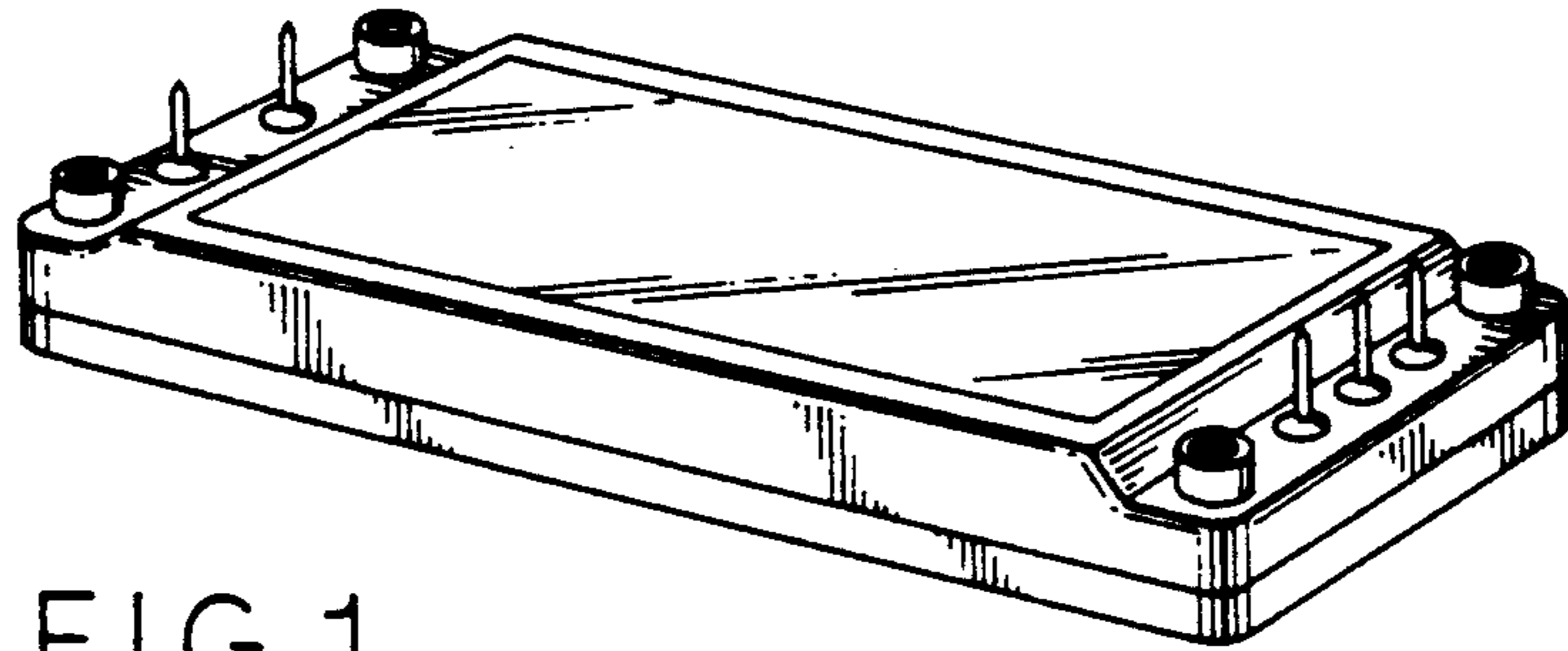

FIG. 1

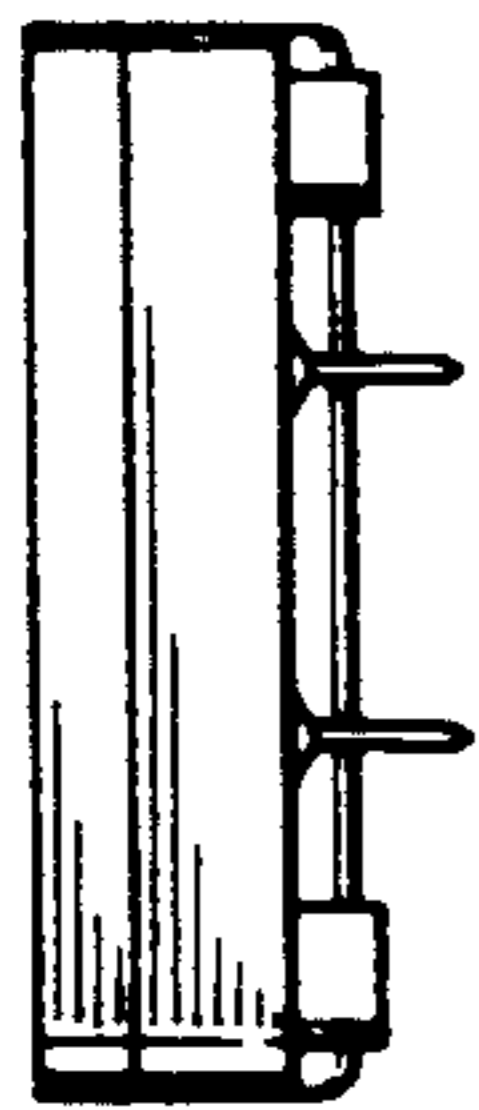

FIG. 5

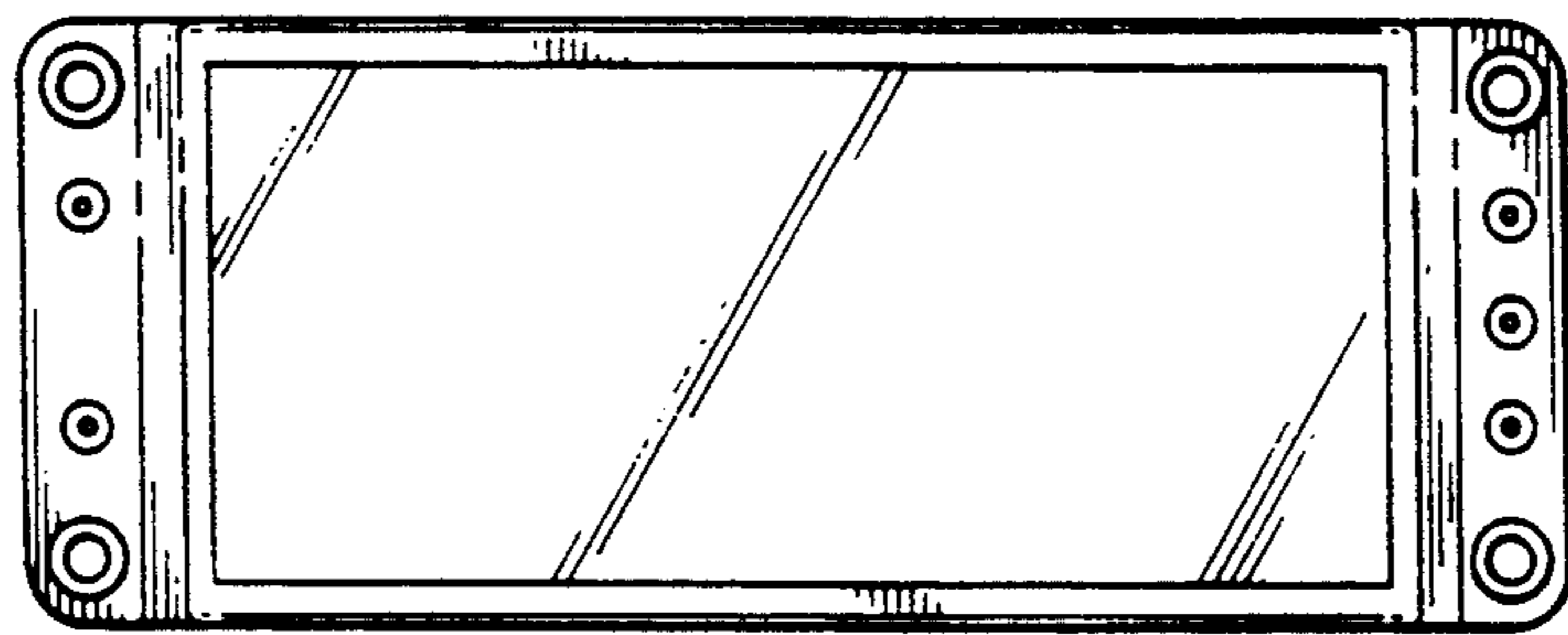

FIG. 2

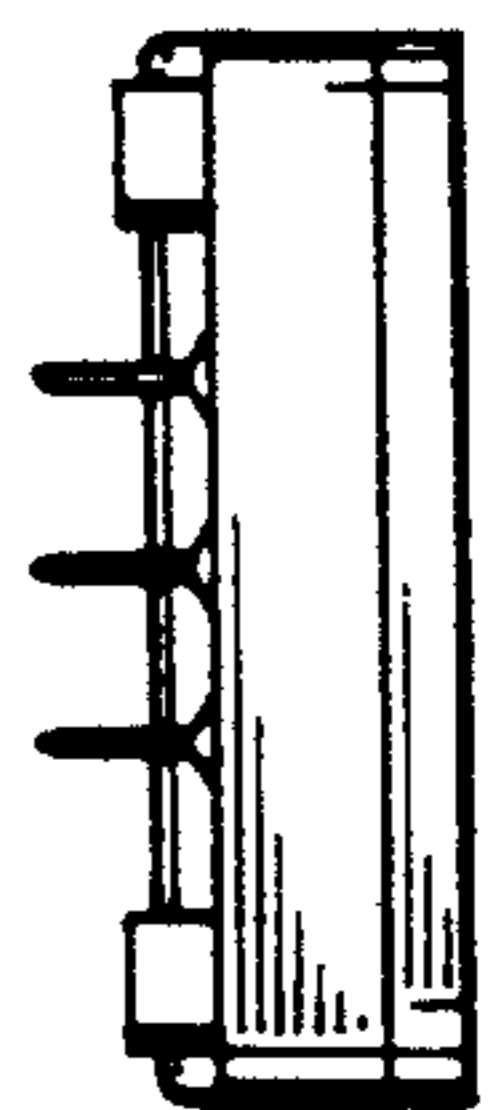

FIG. 6

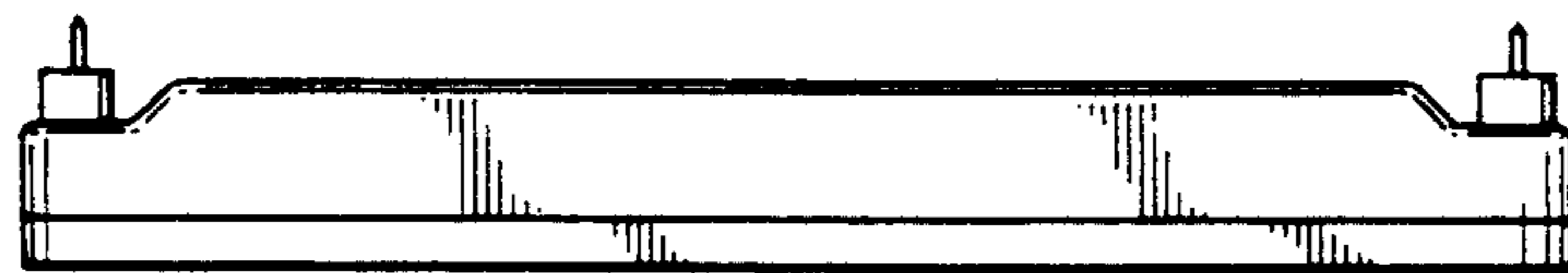

FIG. 3

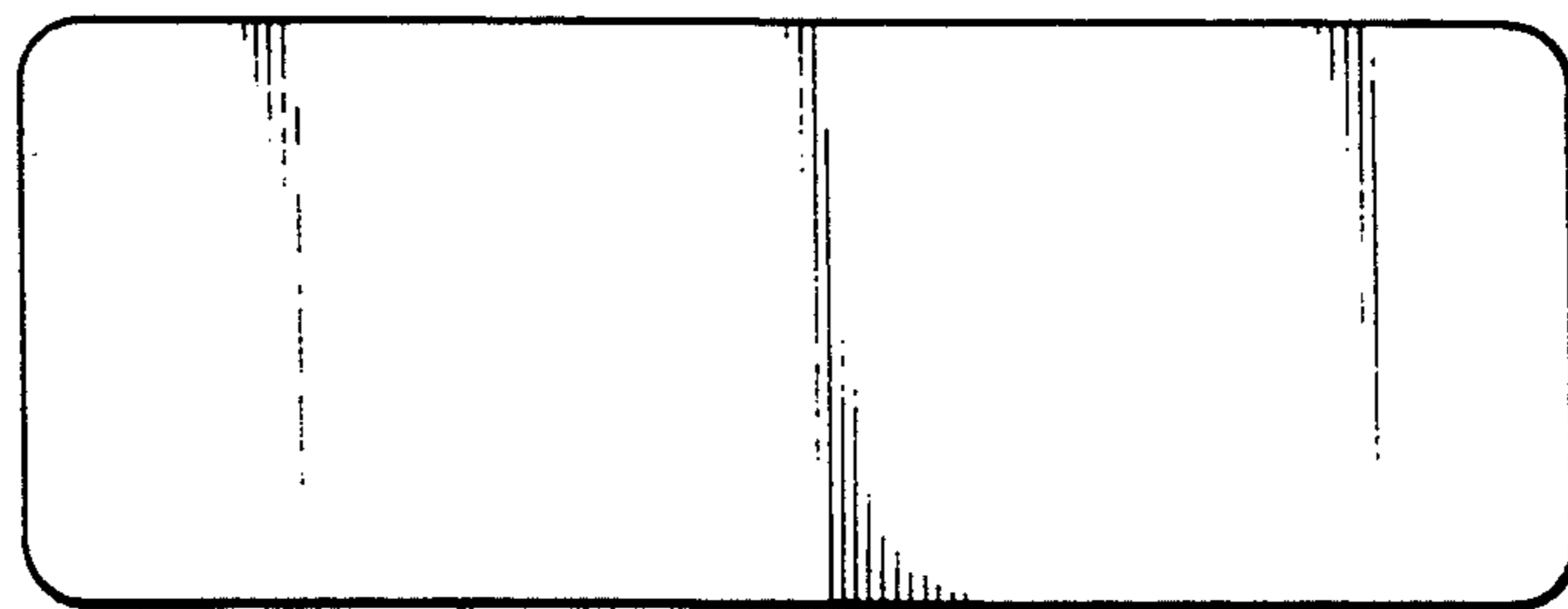

FIG. 4

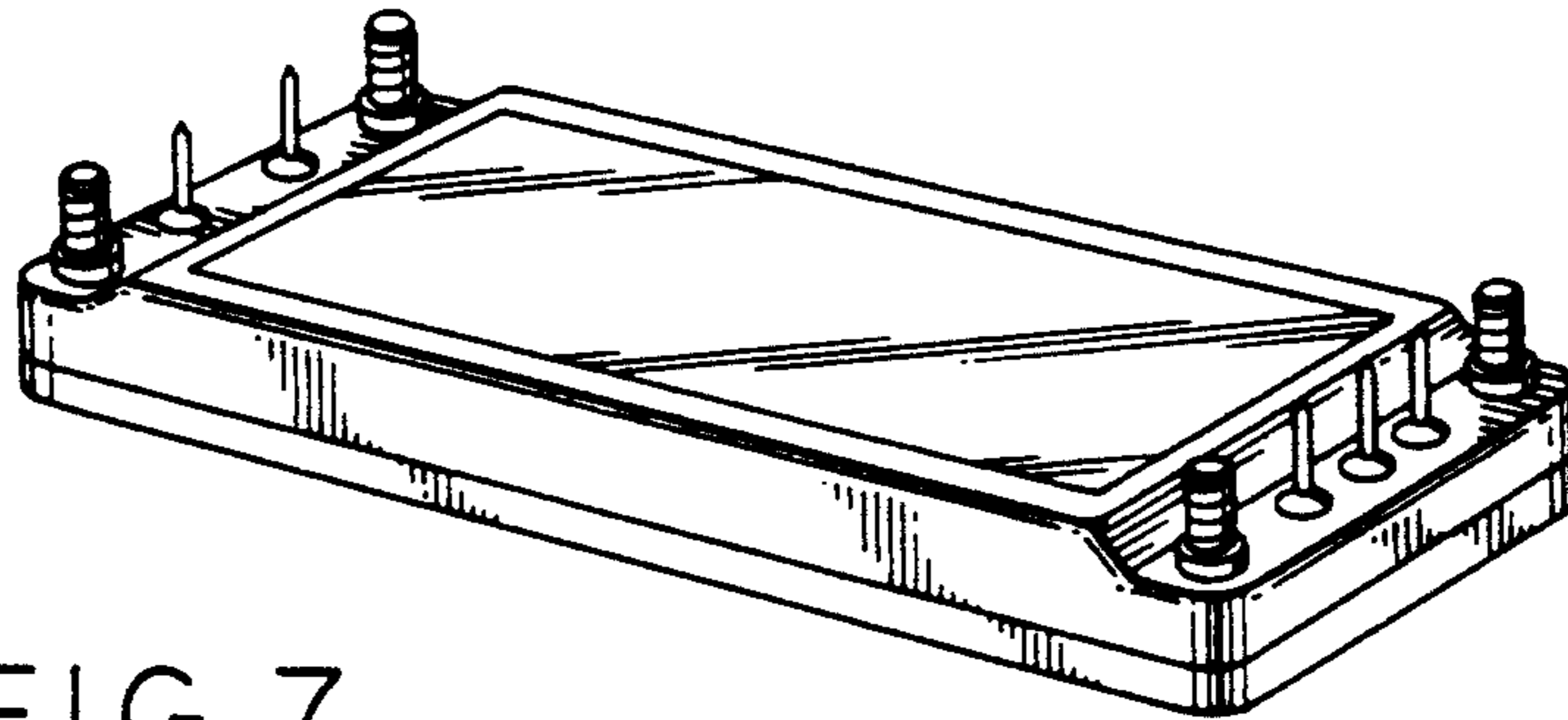

FIG. 7

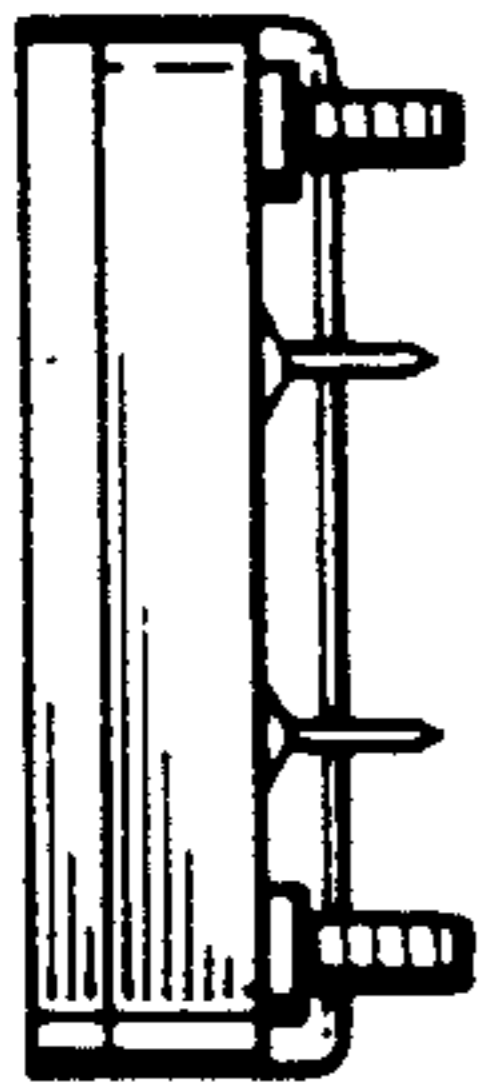

FIG. 11

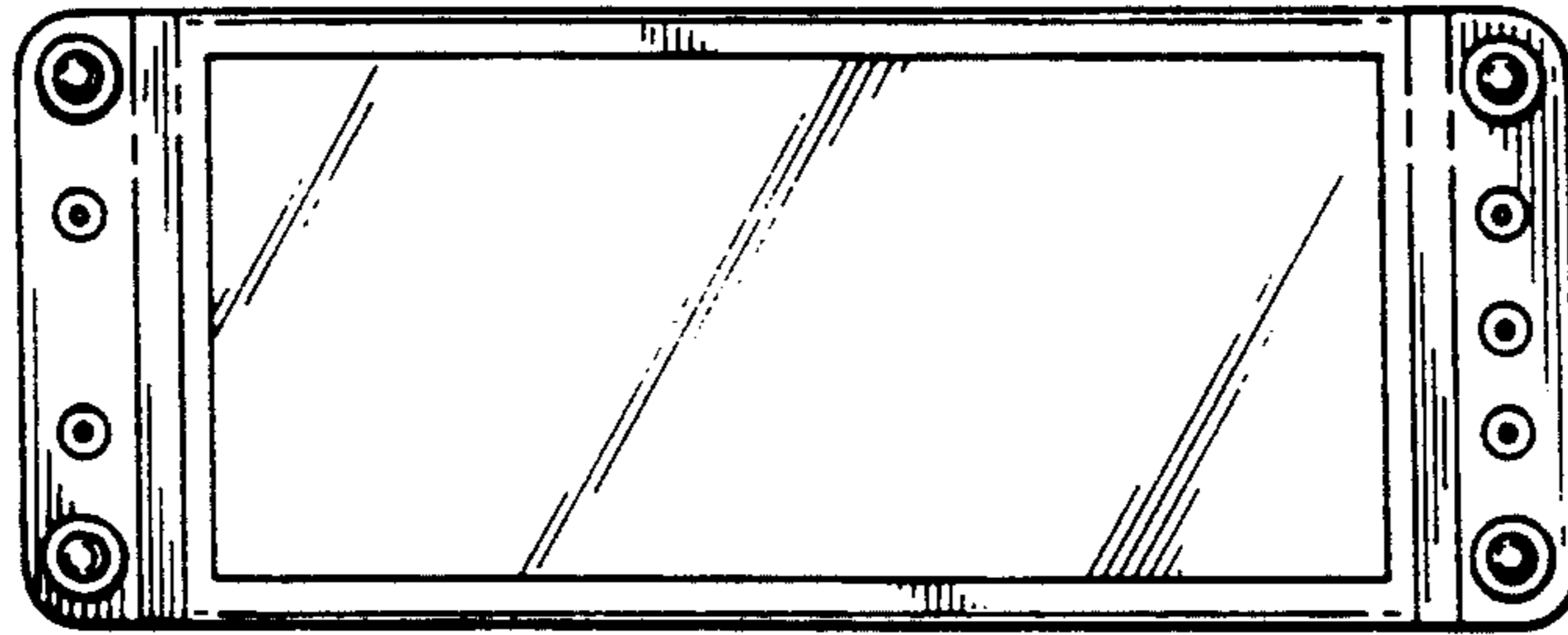

FIG. 8

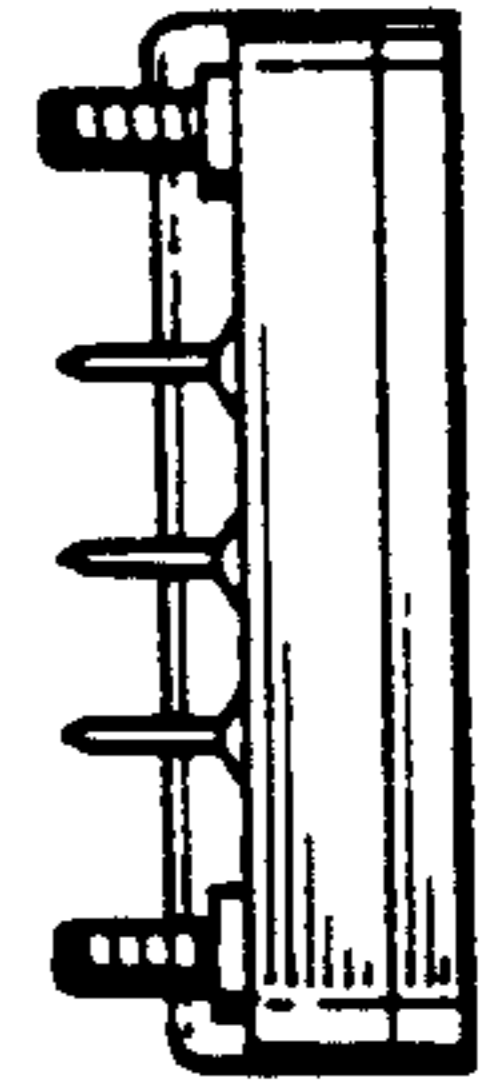

FIG. 12



FIG. 9

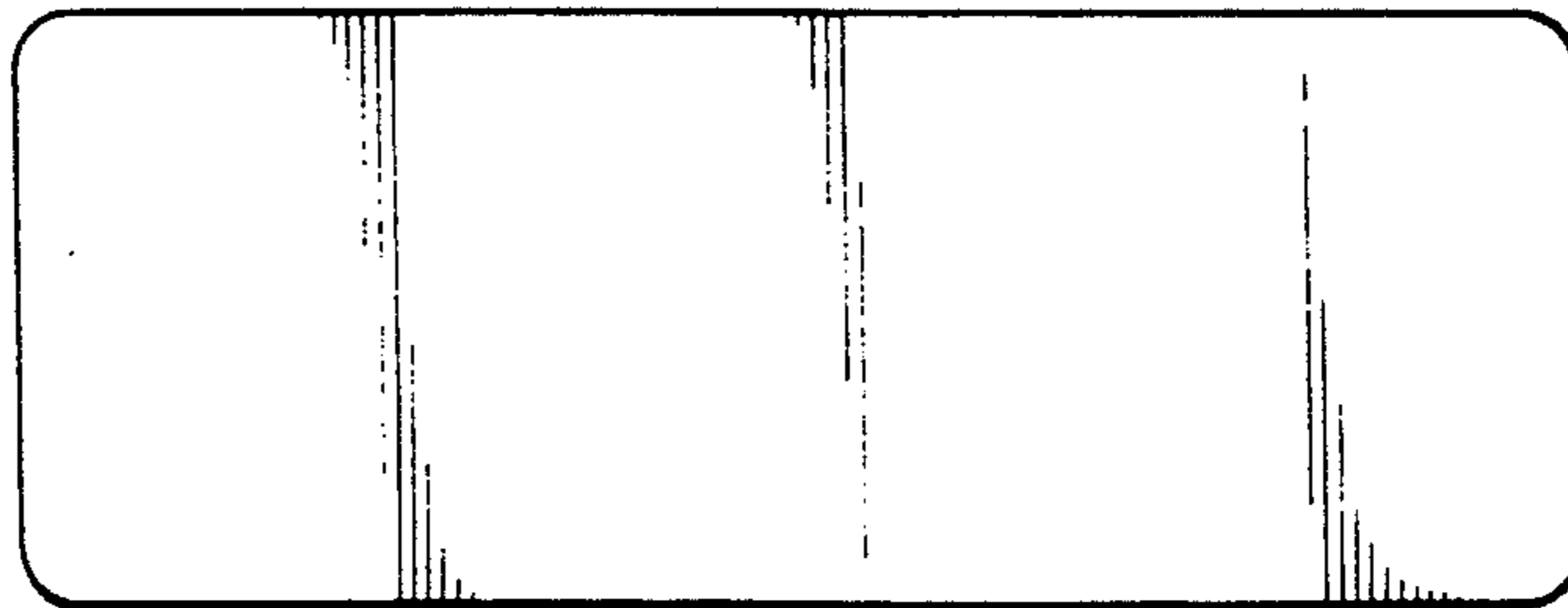

FIG. 10

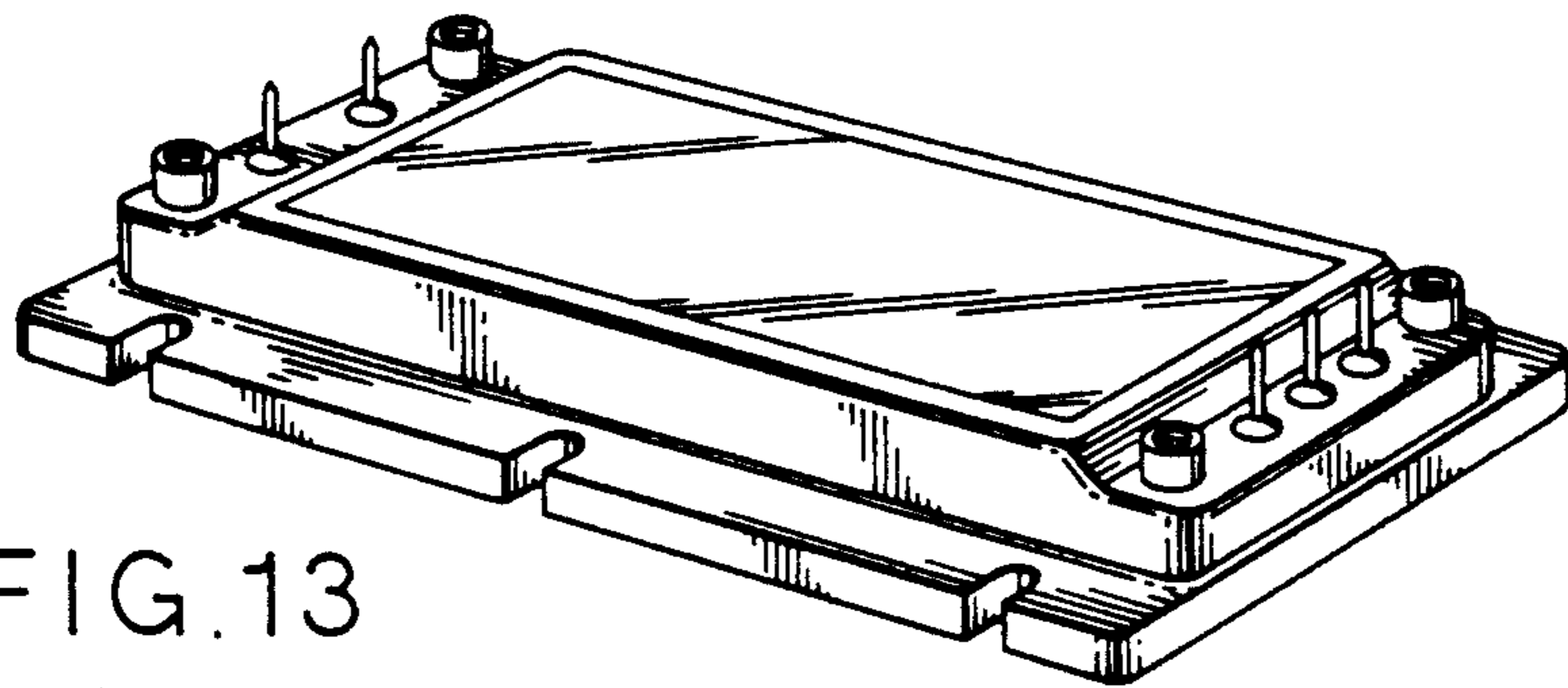

FIG. 13

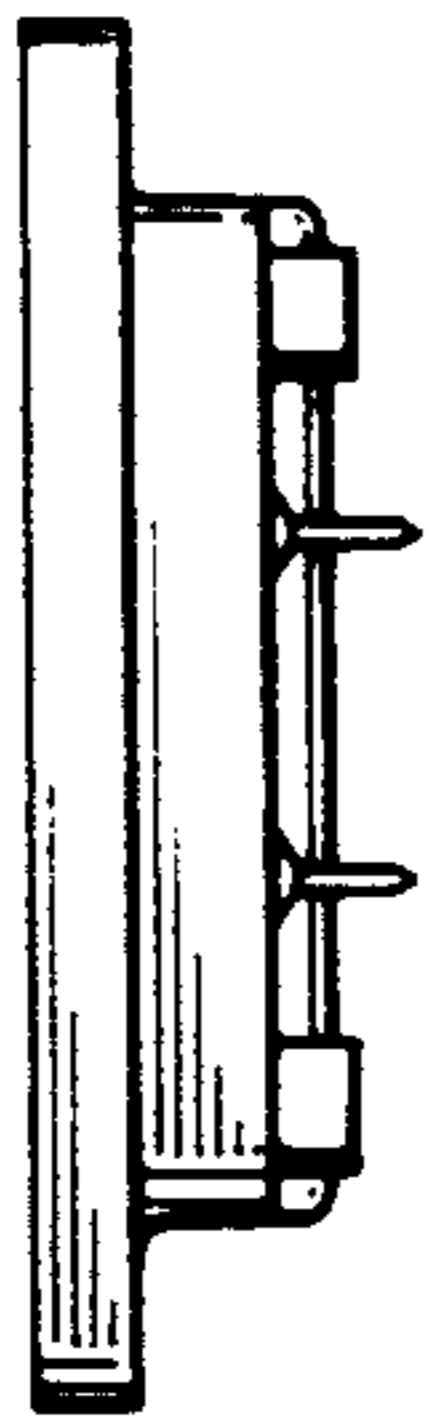

FIG. 17

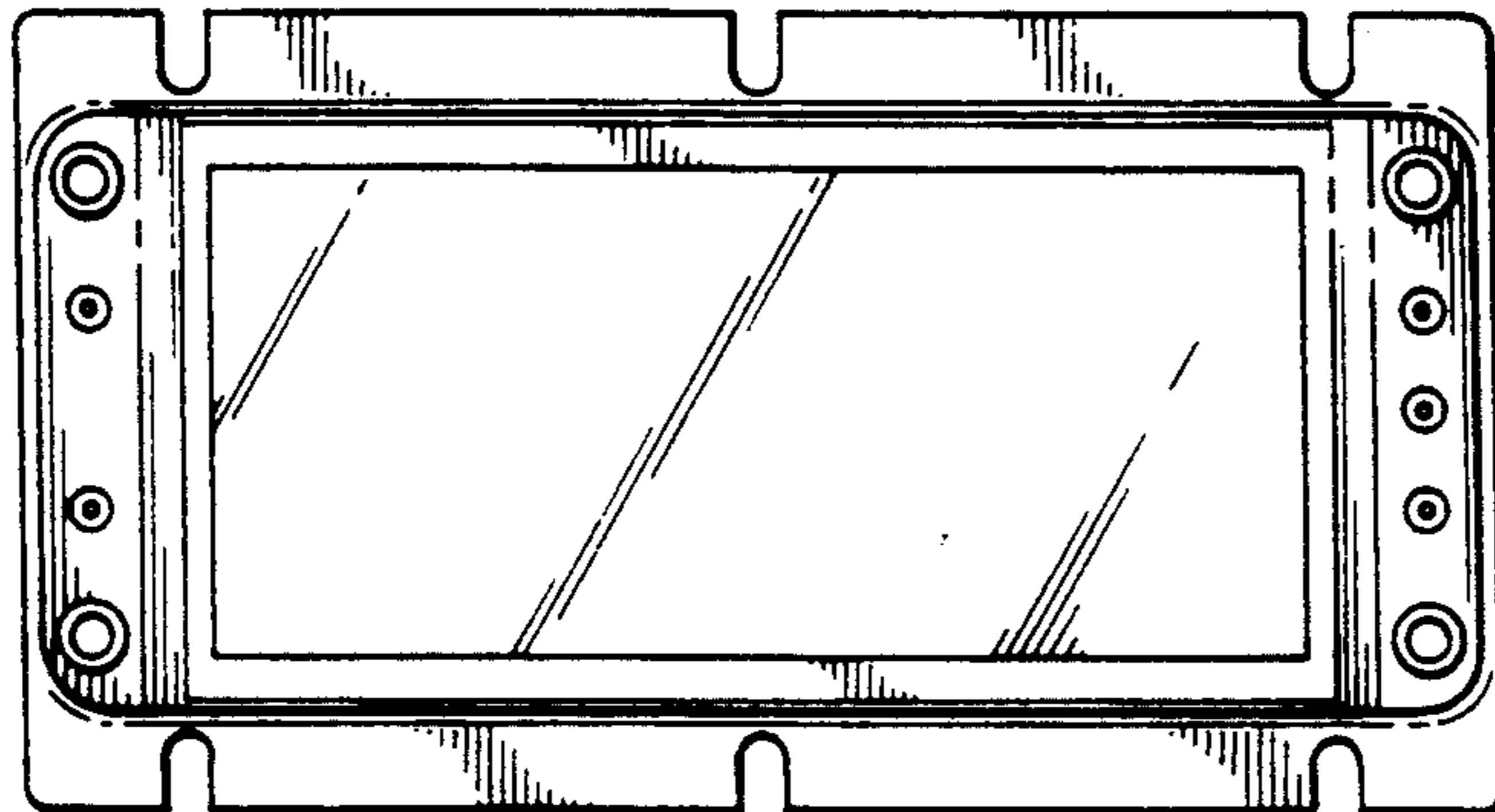

FIG. 14

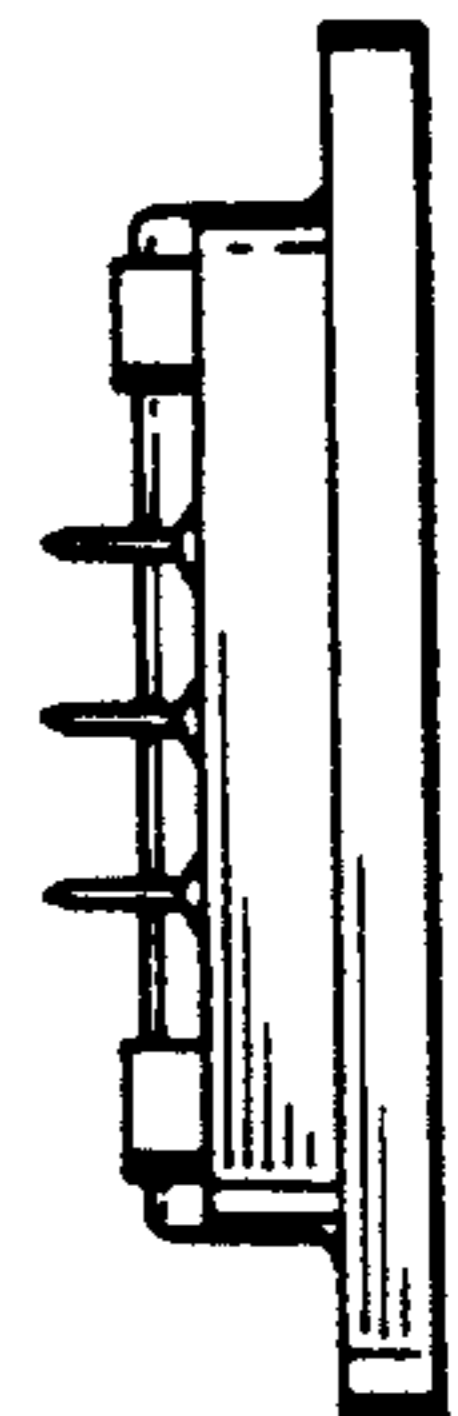
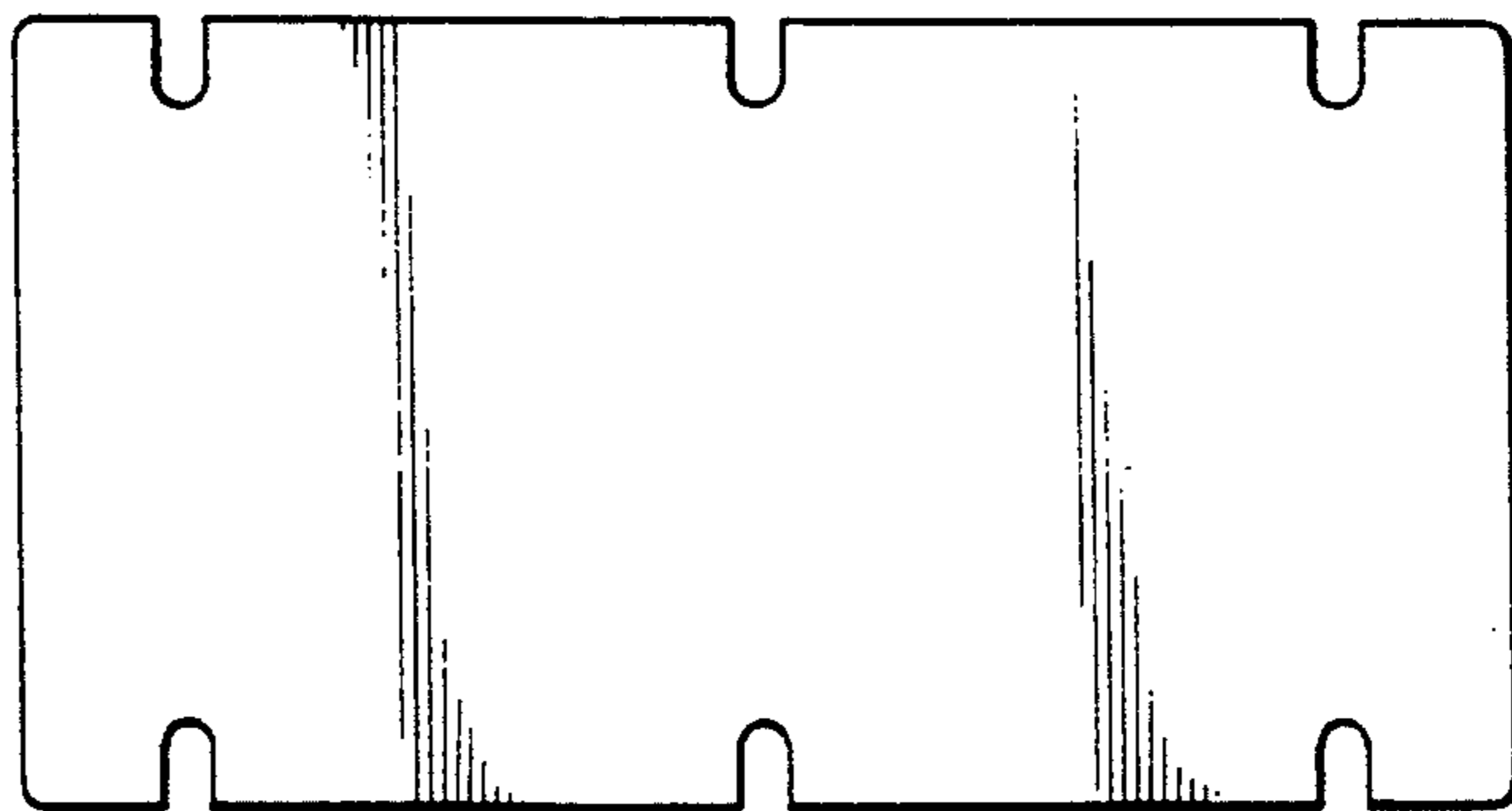

FIG. 18



FIG. 15

FIG. 16



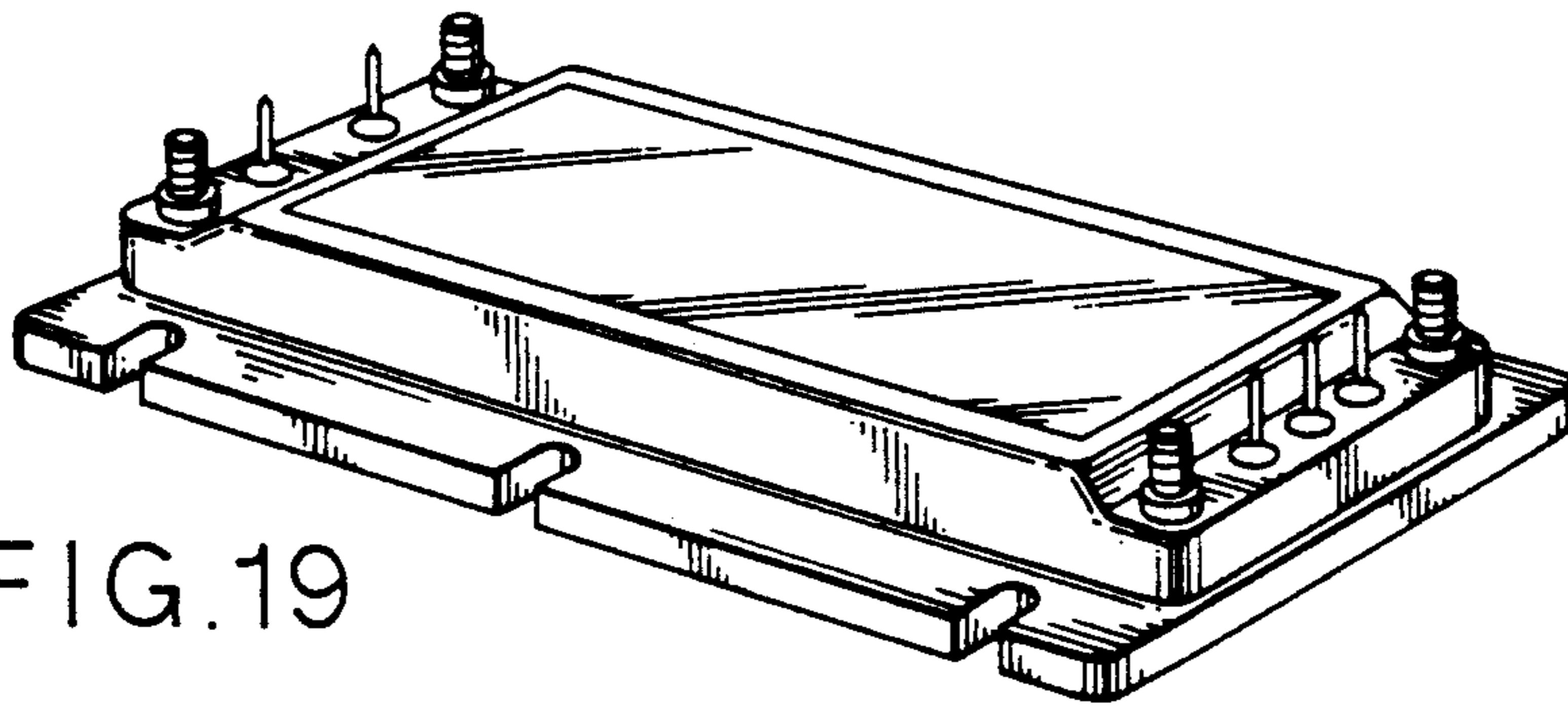

FIG. 19

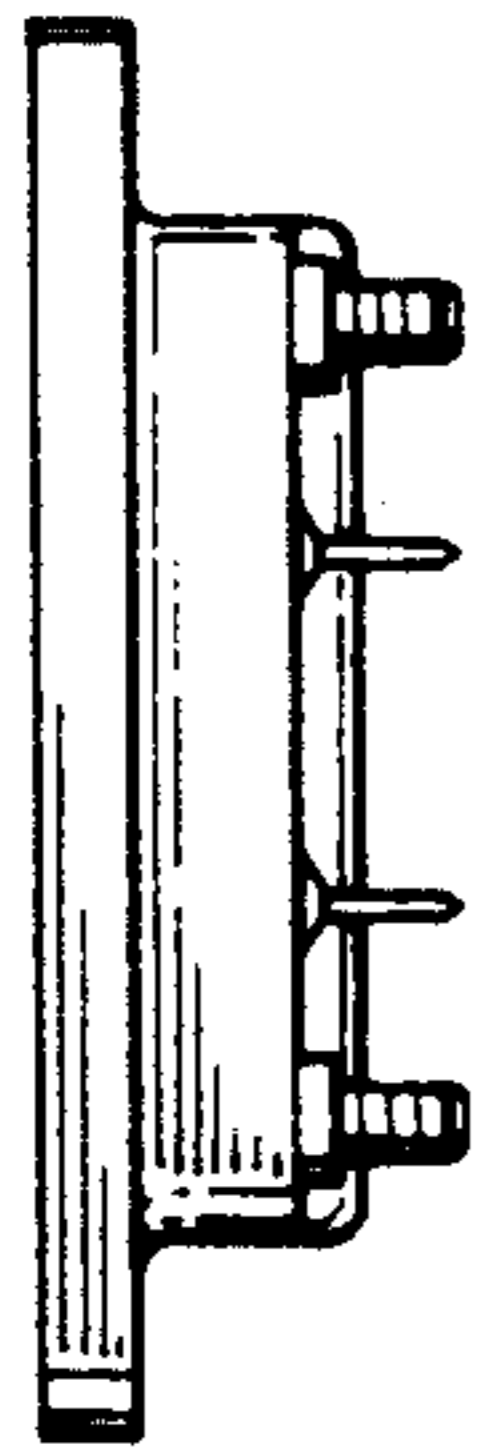

FIG. 23

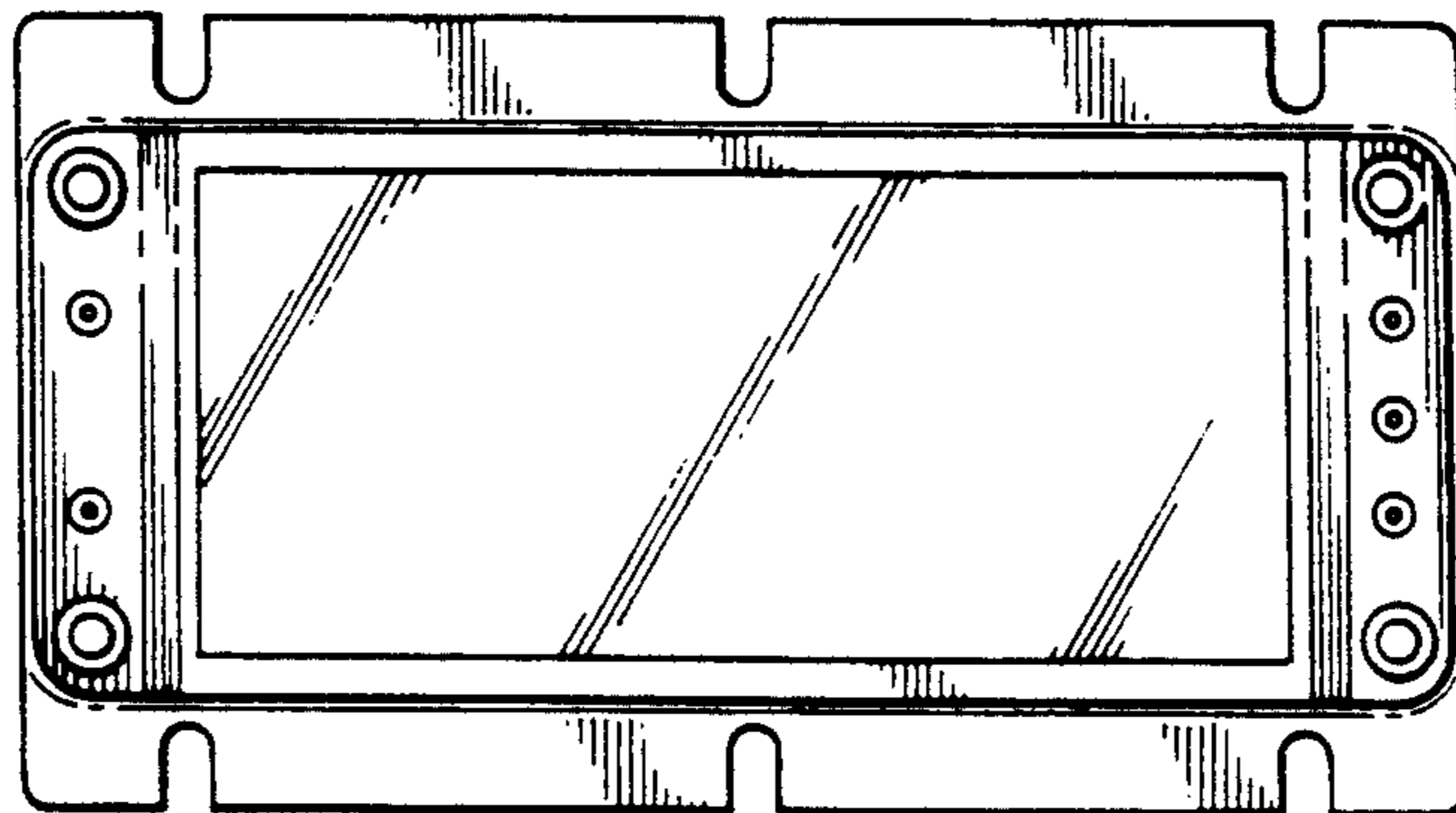

FIG. 20

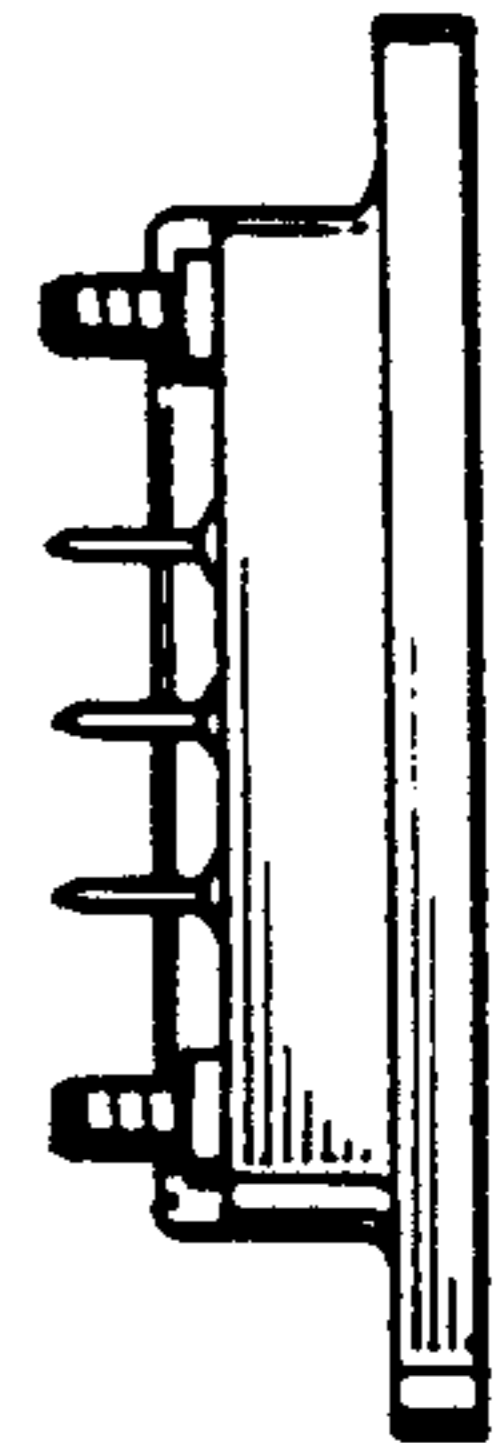
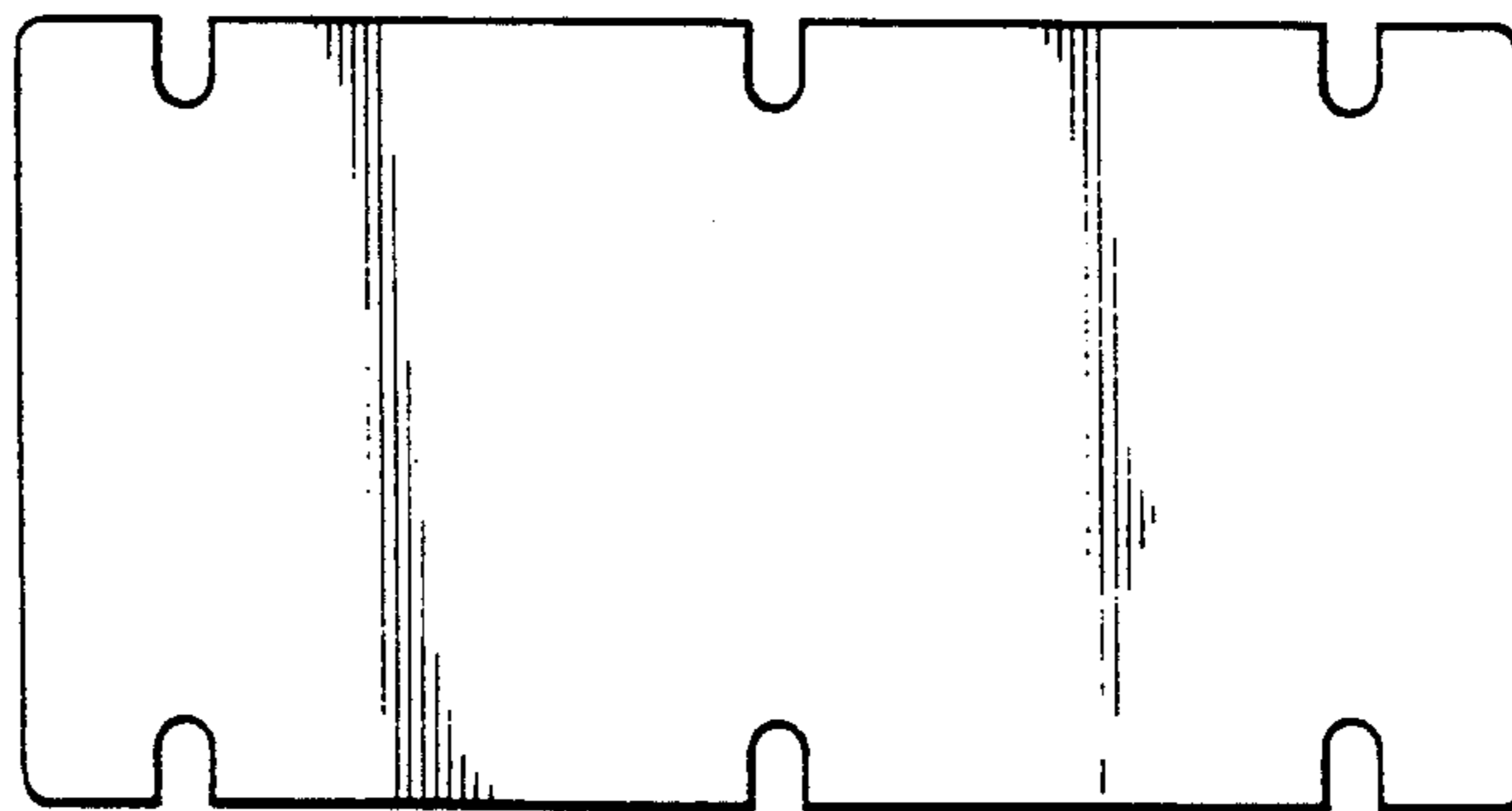

FIG. 24



FIG. 21

FIG. 22



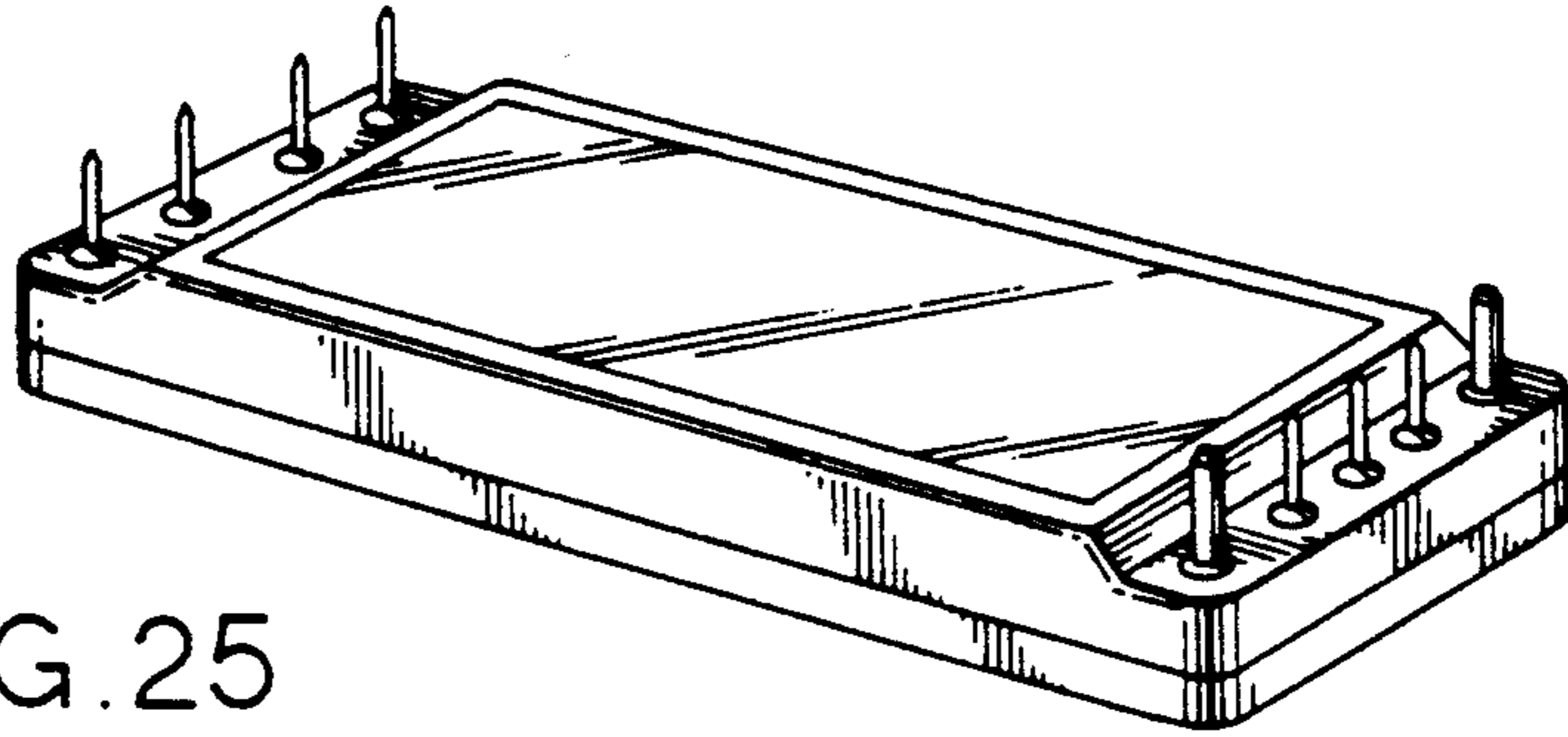

FIG. 25

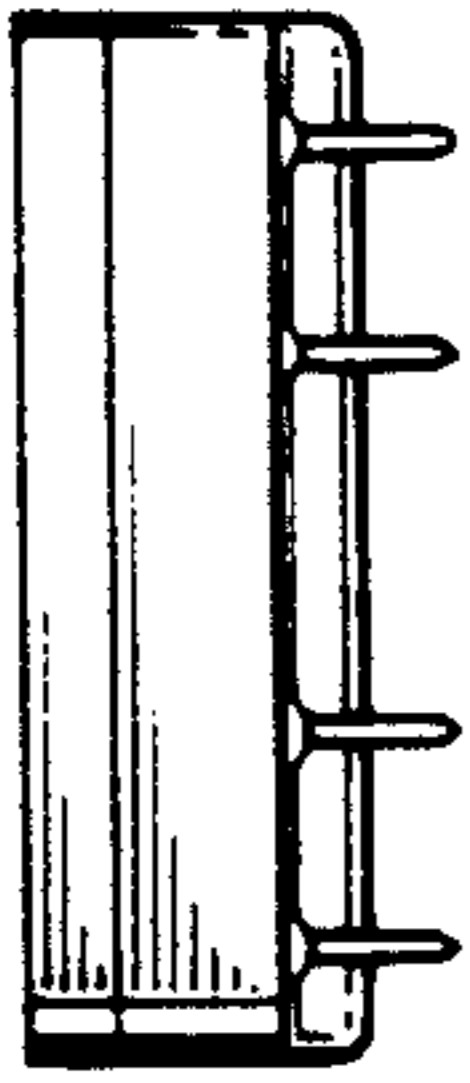

FIG. 29

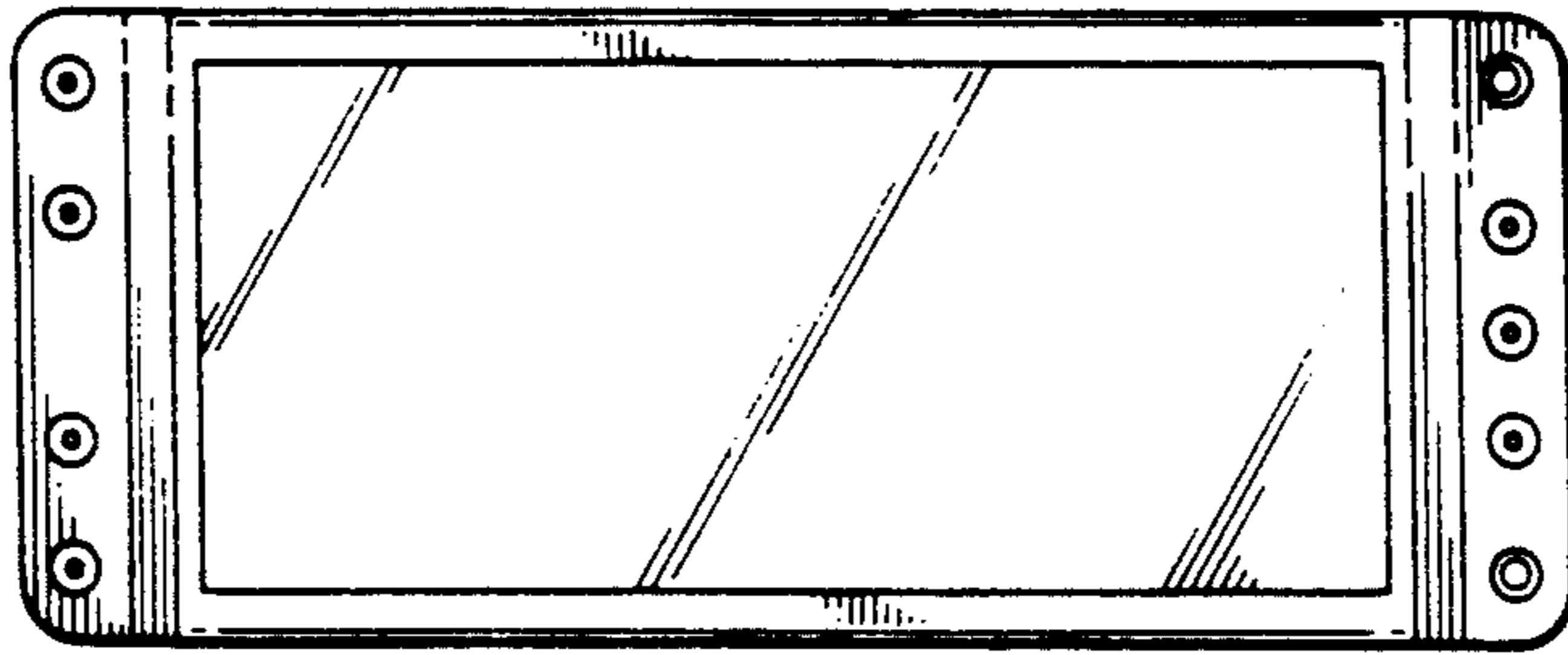

FIG. 26

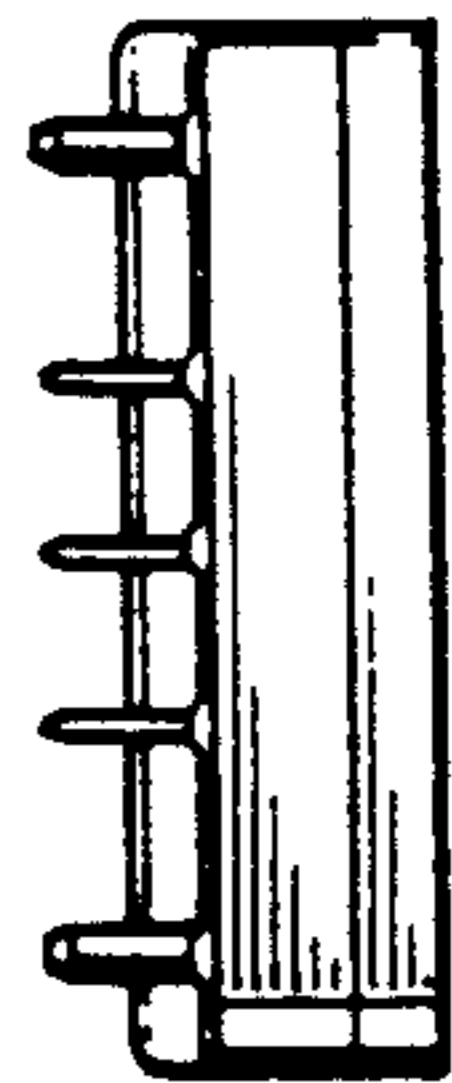

FIG. 30

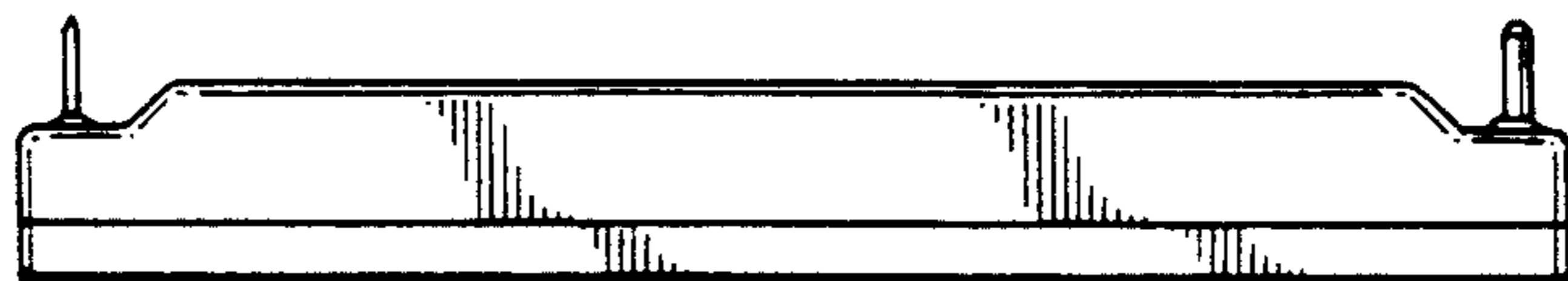

FIG. 27

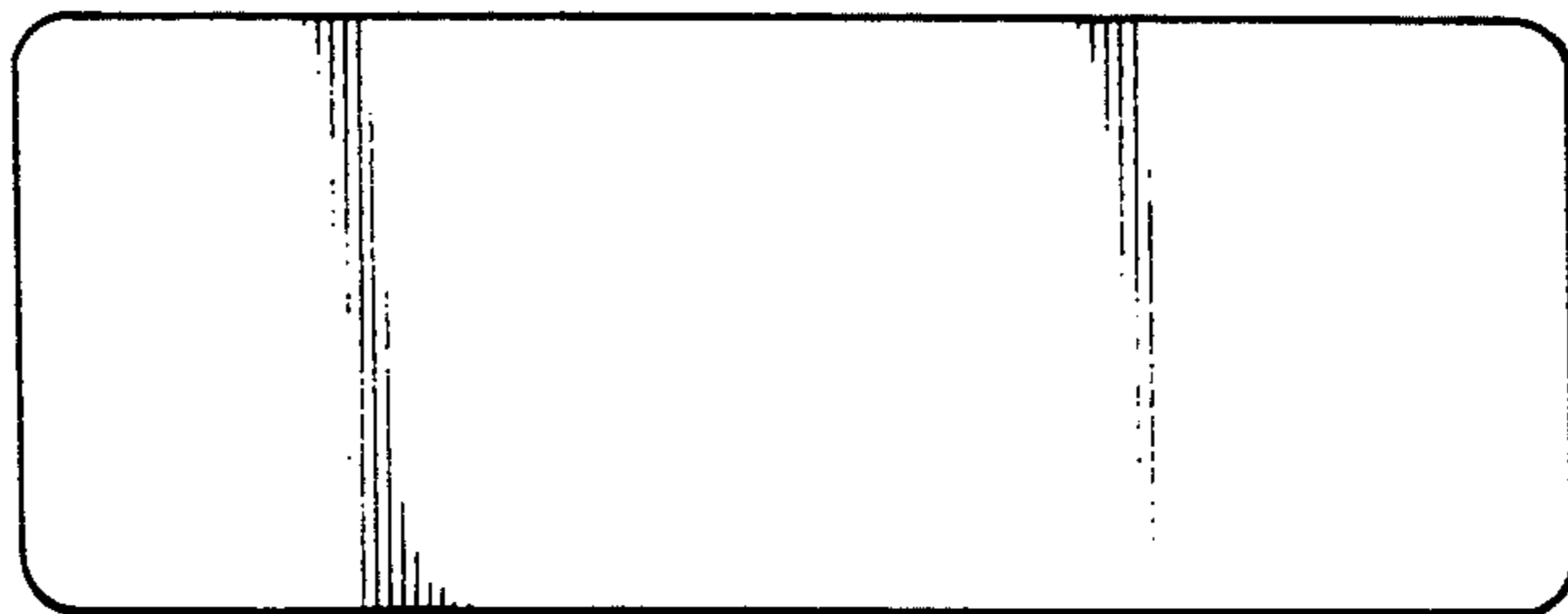

FIG. 28

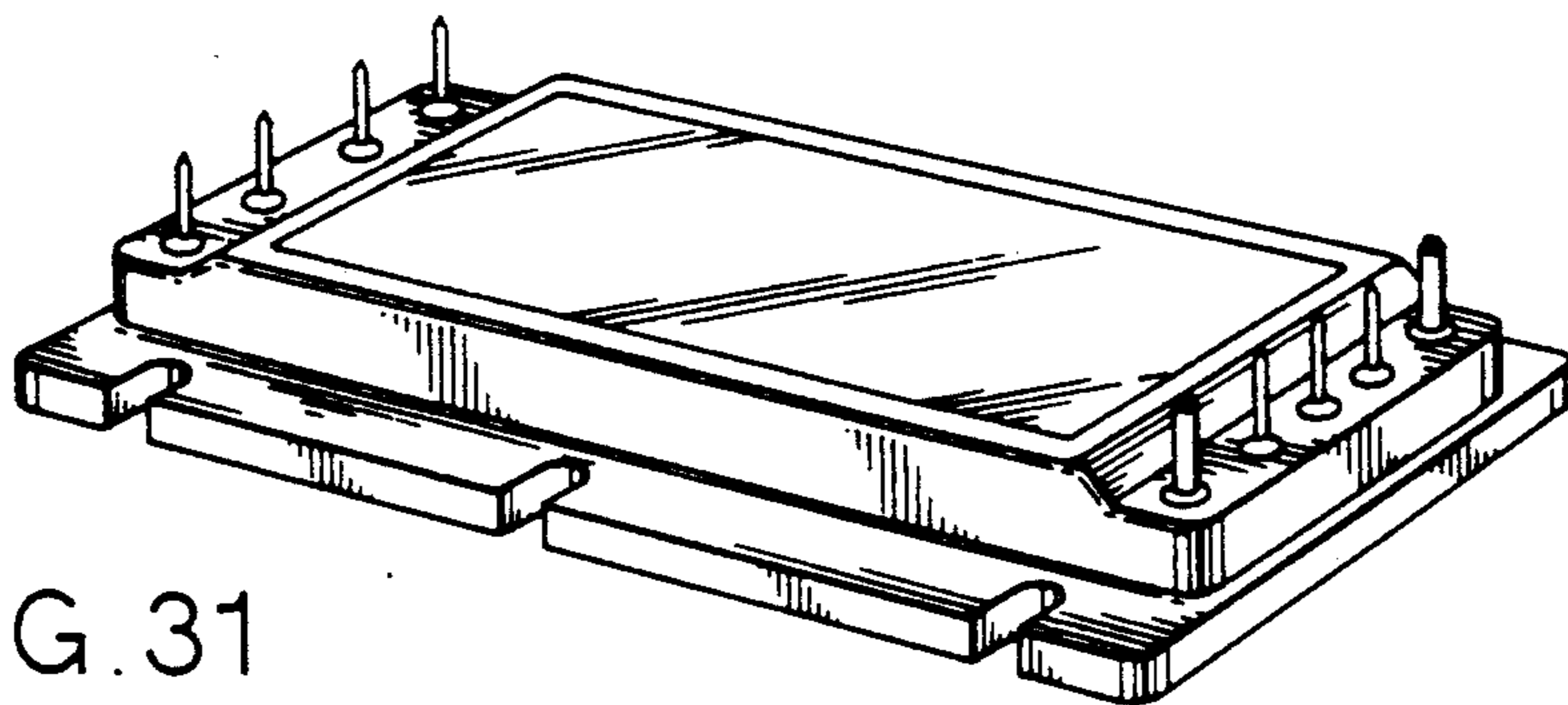

FIG. 31

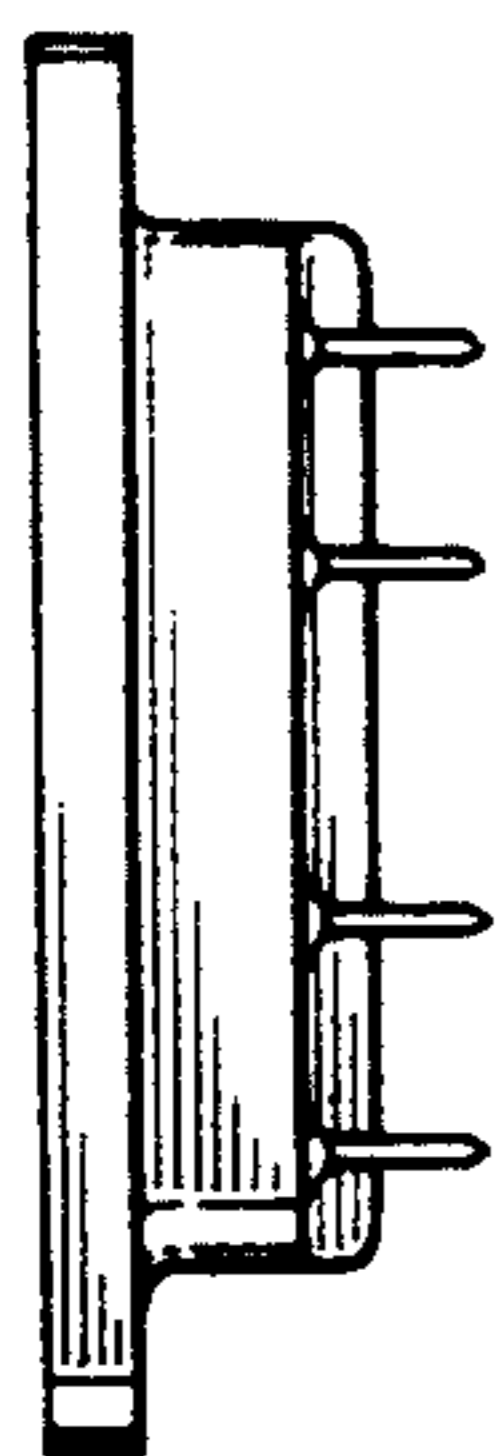

FIG. 35

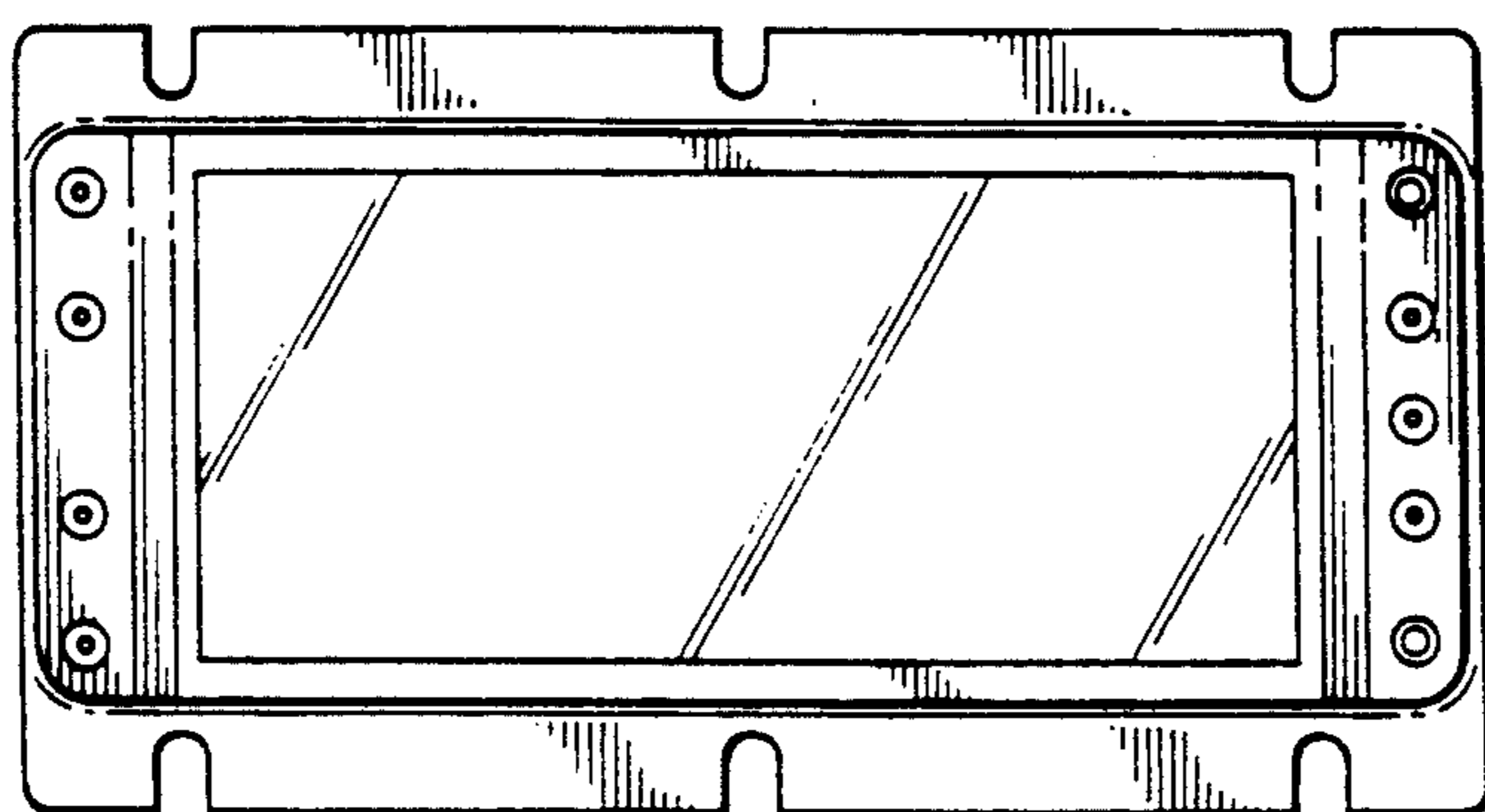

FIG. 32

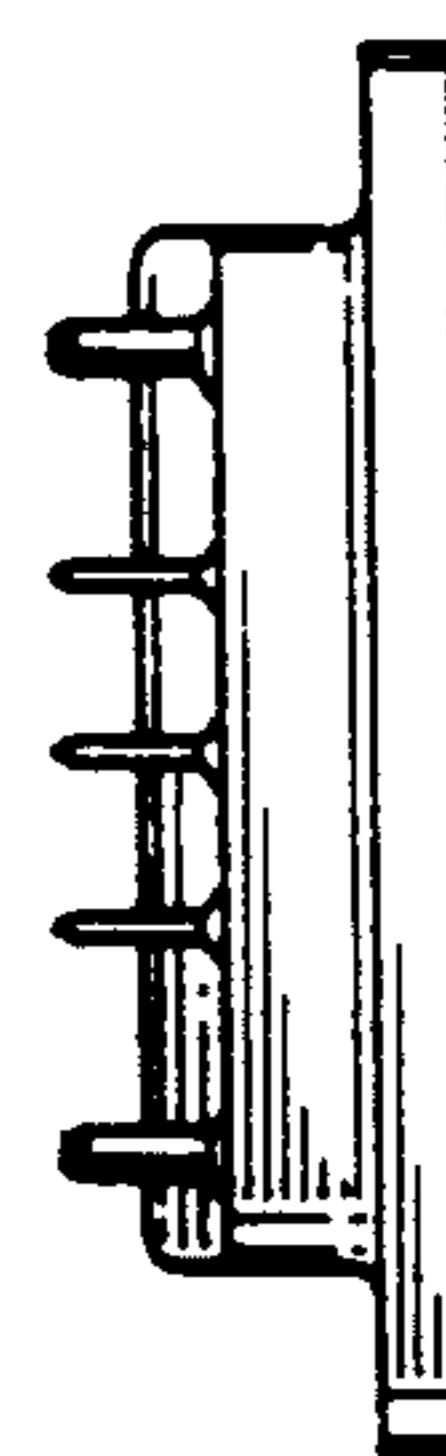

FIG. 36

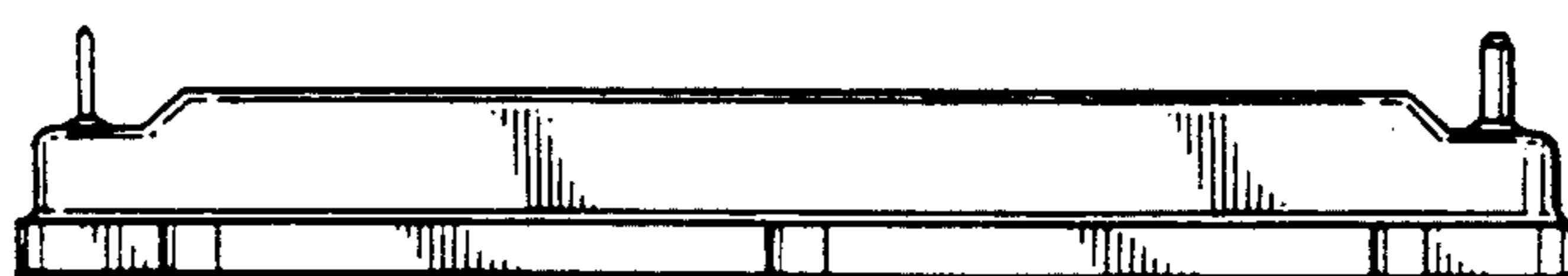

FIG. 33

FIG. 34

