



US00D344924S

# United States Patent [19]

[11] Patent Number: **Des. 344,924**

**Braungart et al.**

[45] Date of Patent: **\*\* Mar. 8, 1994**

## [54] VEHICLE WHEEL EXTERIOR SURFACE

[75] Inventors: **Martin Braungart**, Alpirsbach;  
**Graham Thorpe**, Munich, both of  
Fed. Rep. of Germany

[73] Assignee: **BBS Kraftfahrzeugtechnik AG**,  
Schiltach, Fed. Rep. of Germany

[\*\*] Term: **14 Years**

[21] Appl. No.: **721,225**

[22] Filed: **Jun. 25, 1991**

[52] U.S. Cl. .... **D12/211**

[58] Field of Search ..... **301/63 R, 64 R, 65,**  
**301/66; D12/209, 211, 135**

## [56] References Cited

### U.S. PATENT DOCUMENTS

D. 47,390 5/1915 Schwab ..... D12/135  
D. 268,261 3/1983 Boyer ..... D12/211

### OTHER PUBLICATIONS

Road & Track, Oct. 1990, p. 160, Dötz Wheel, top left side of page.

Car & Driver, Apr. 1990, p. 87, Nissan Stanza Wheel, center left side of page.

1990 Tread Design Guide, p. 89, RW Wheels Rush Wheel, third row down from top & second wheel in from left side of page.

*Primary Examiner*—James M. Gandy

*Attorney, Agent, or Firm*—Dick and Harris

## [57] CLAIM

The ornamental design for a vehicle wheel exterior surface, as shown and described.

## DESCRIPTION

FIG. 1 is a front elevation of the vehicle wheel exterior surface in a preferred embodiment, showing our new ornamental design;

FIG. 2 is a front enlarged fragmentary perspective view thereof;

FIG. 3 is a front enlarged fragmentary perspective view thereof;

FIG. 4 is a front enlarged fragmentary perspective view thereof;

FIG. 5 is a front perspective view thereof;

FIG. 6 is a sectional view thereof taken along line 6—6 in FIG. 1;

FIG. 7 is a front elevation of a vehicle wheel exterior surface showing a second embodiment of our new ornamental design, the sole difference being in the reduced length of the spokes;

FIG. 8 is a front enlarged fragmentary perspective view thereof;

FIG. 9 is a front enlarged fragmentary perspective thereof;

FIG. 10 is a front enlarged fragmentary perspective thereof; and,

FIG. 11 is a front perspective view thereof.

The broken line showing of environmental structure in FIGS. 1, 3, 5, 7, 9 and 11 of the drawing is for illustrative purposes only and forms no part of the claimed design.

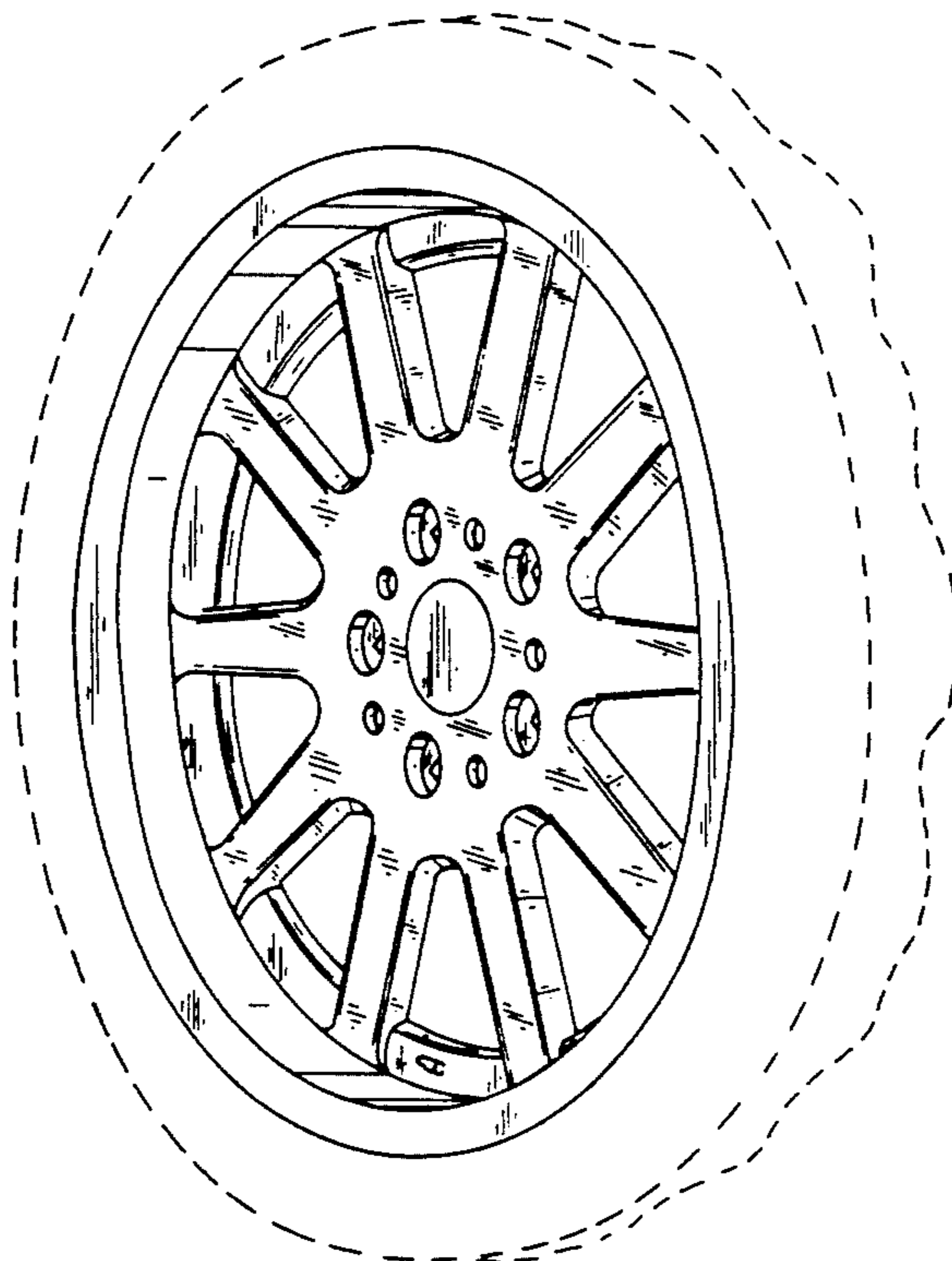

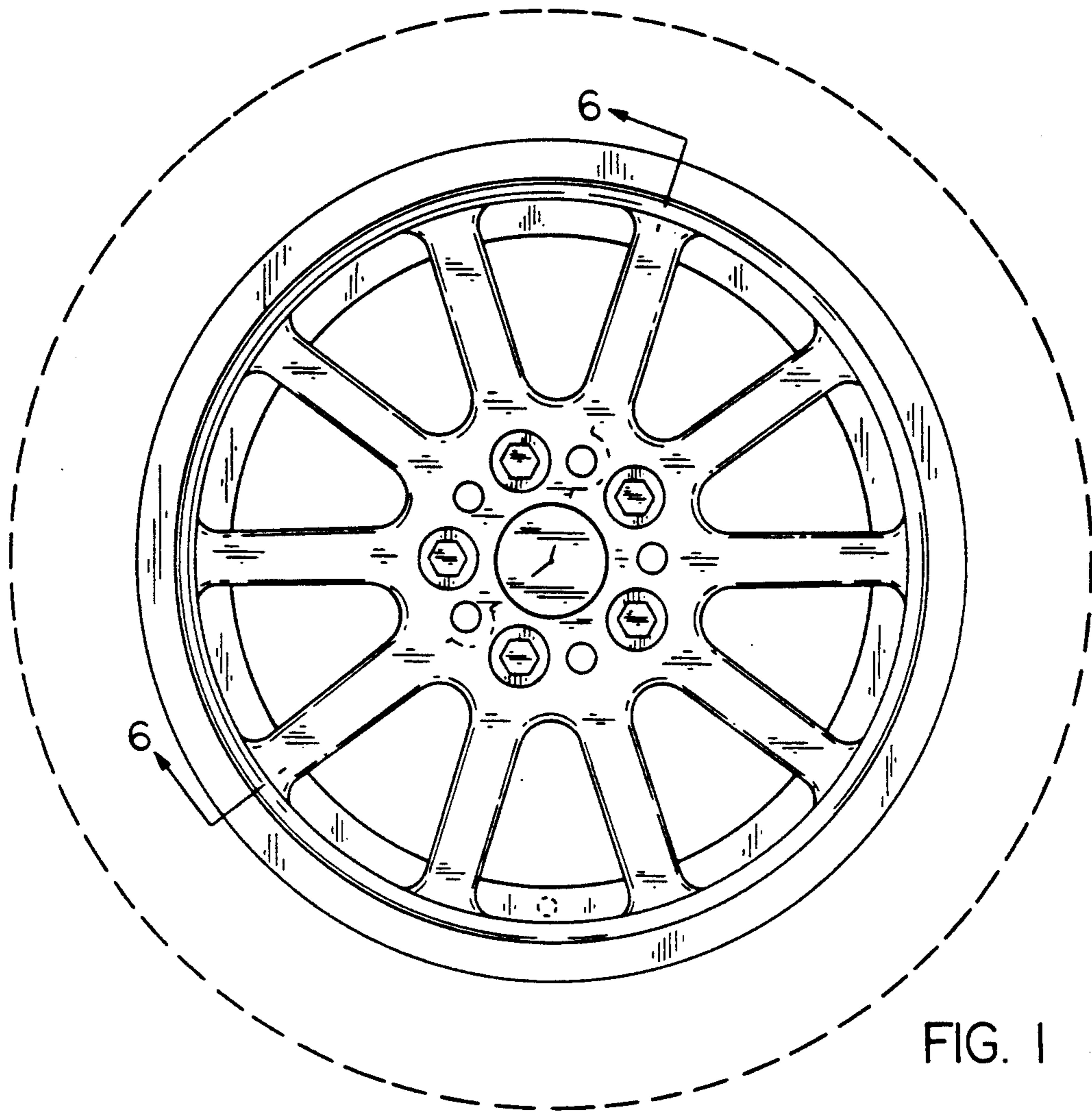

FIG. 1

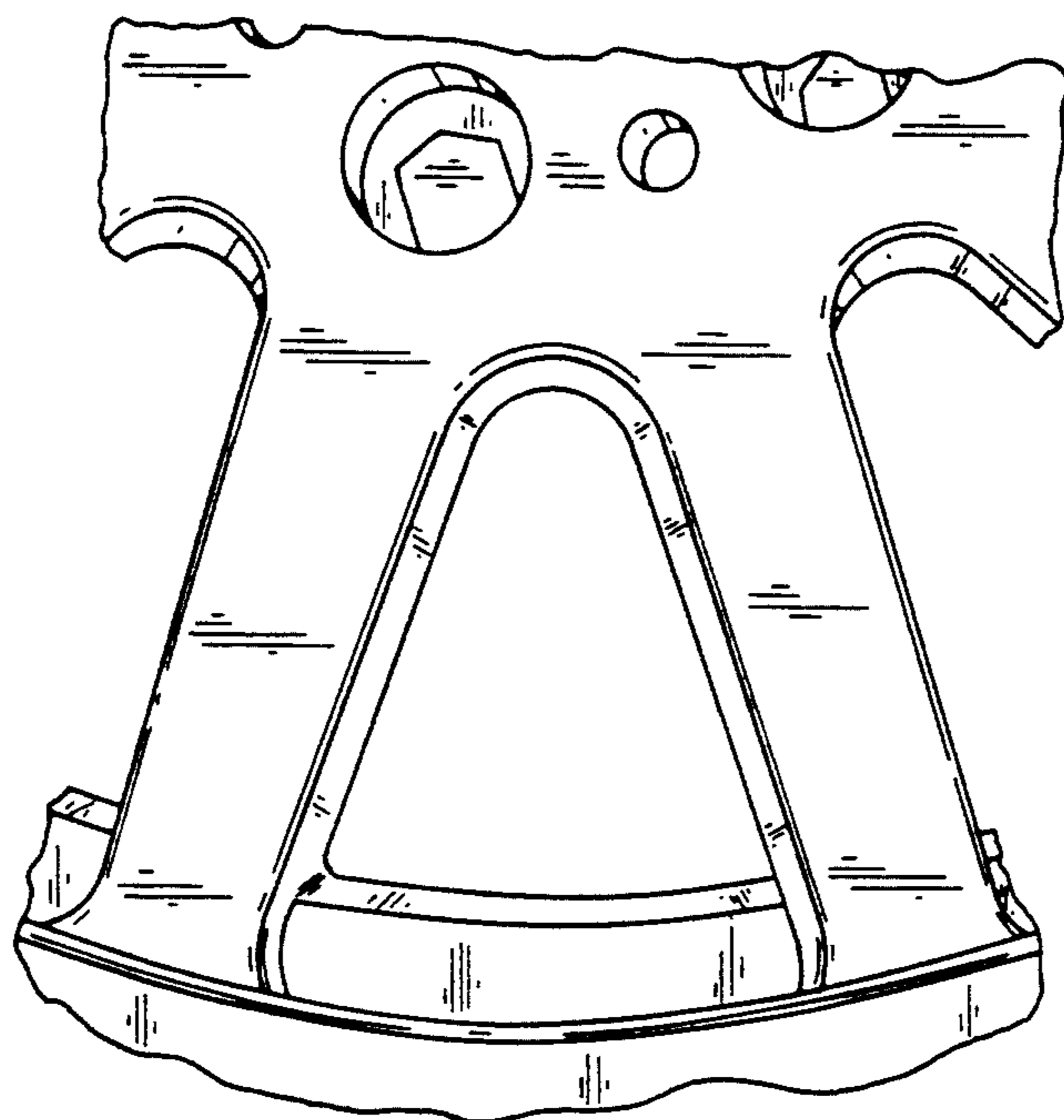

FIG. 2

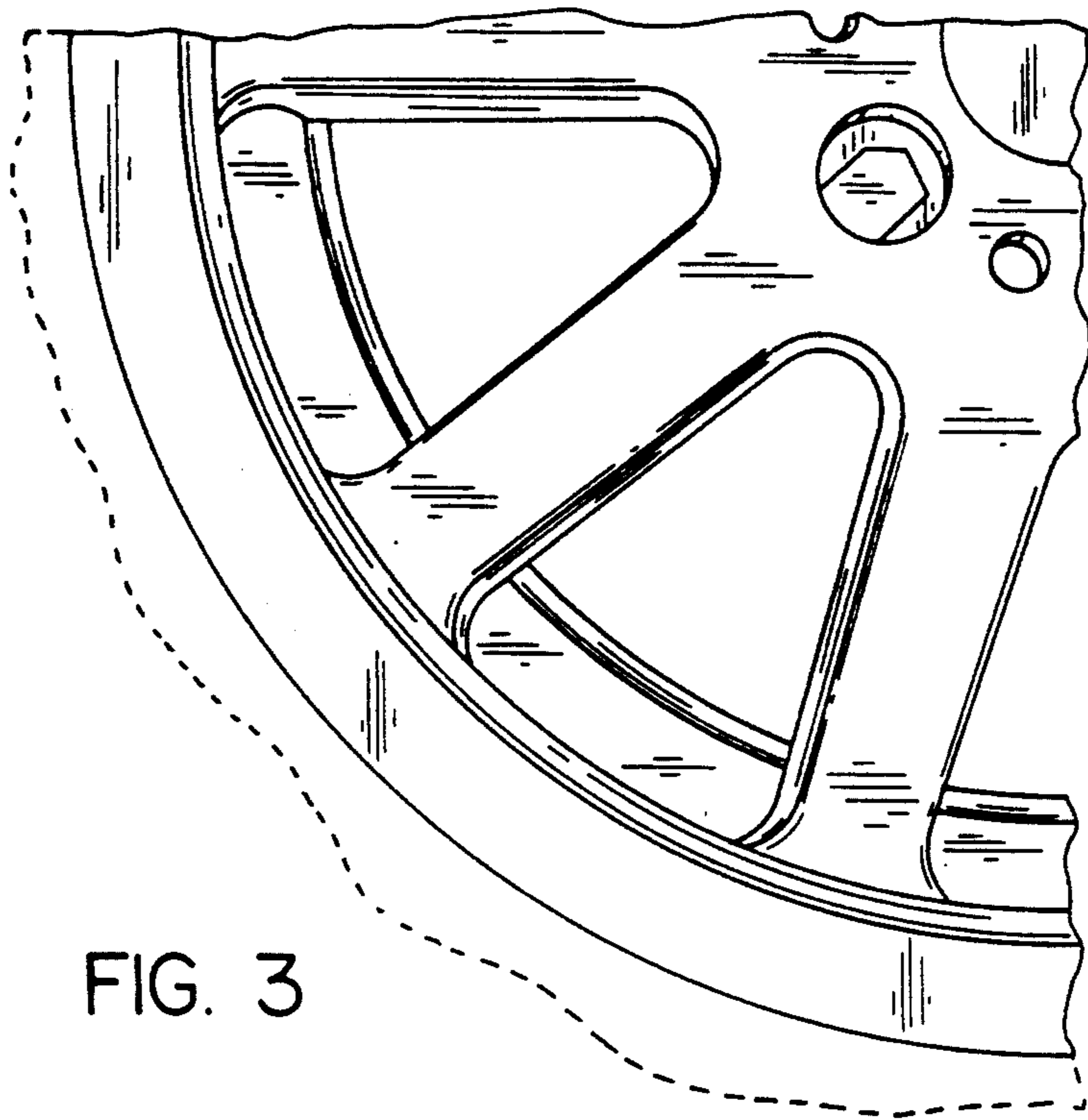

FIG. 3

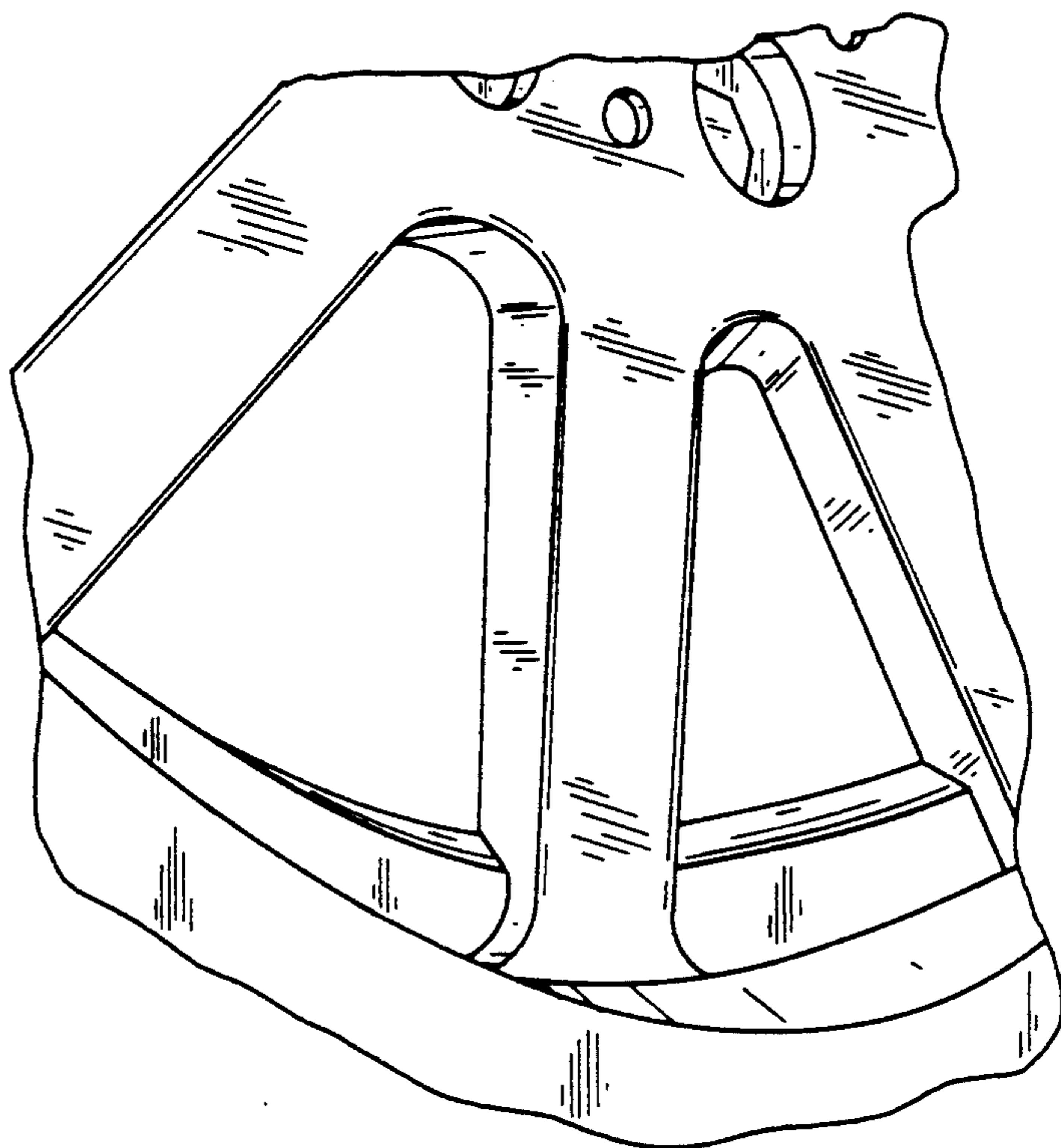

FIG. 4

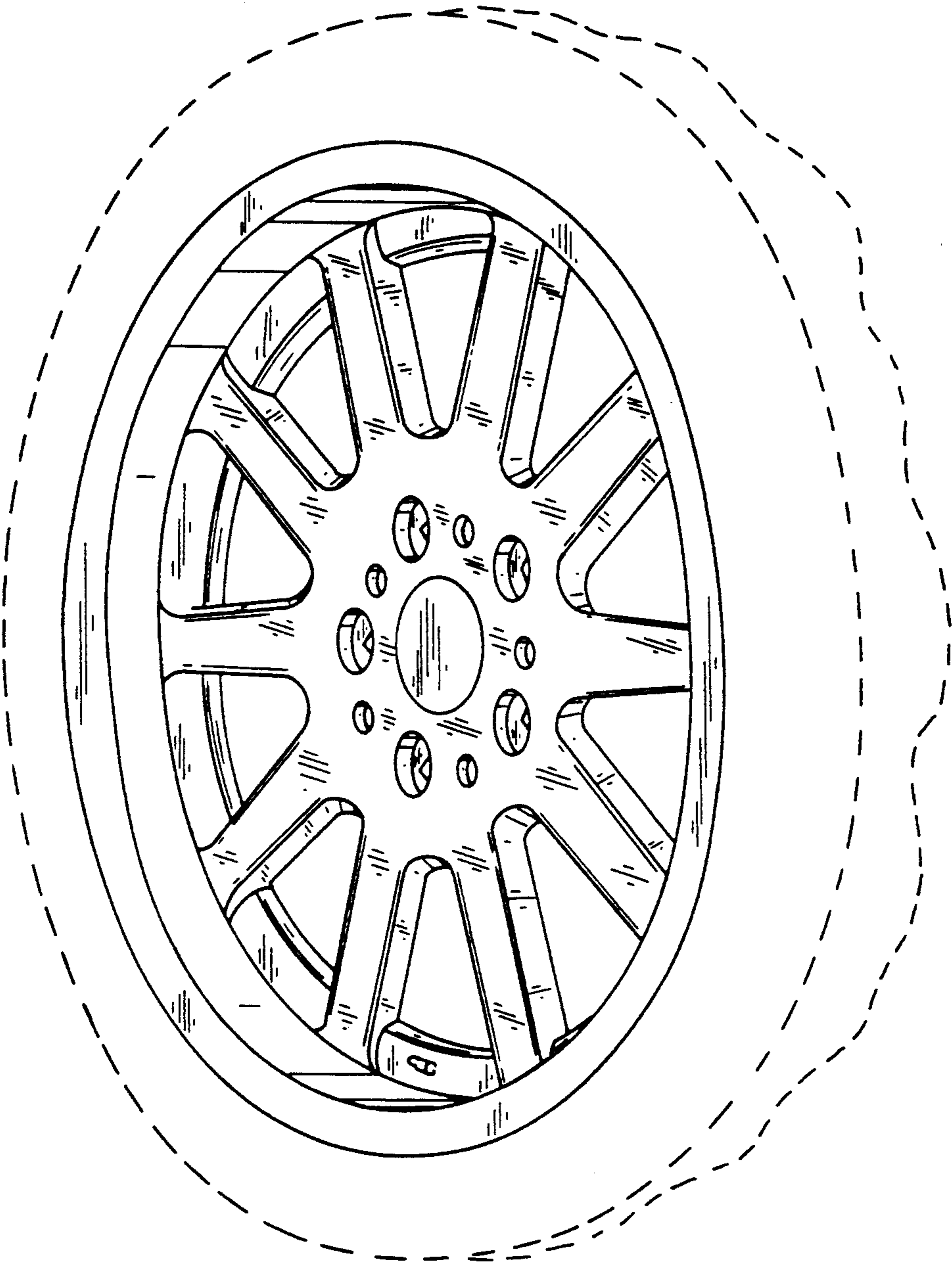

FIG. 5

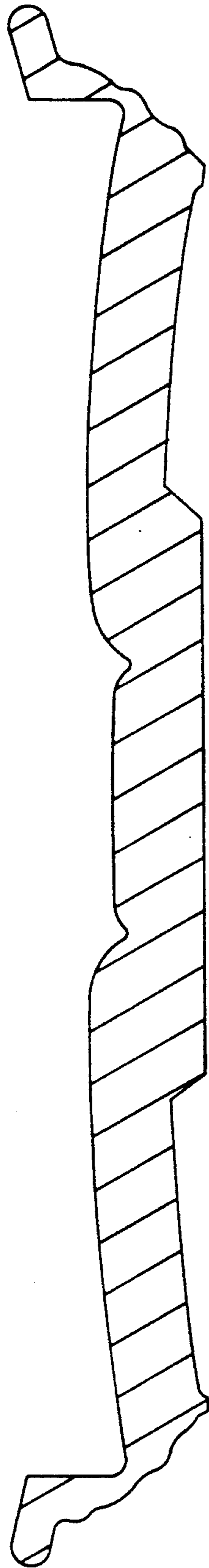

FIG. 6

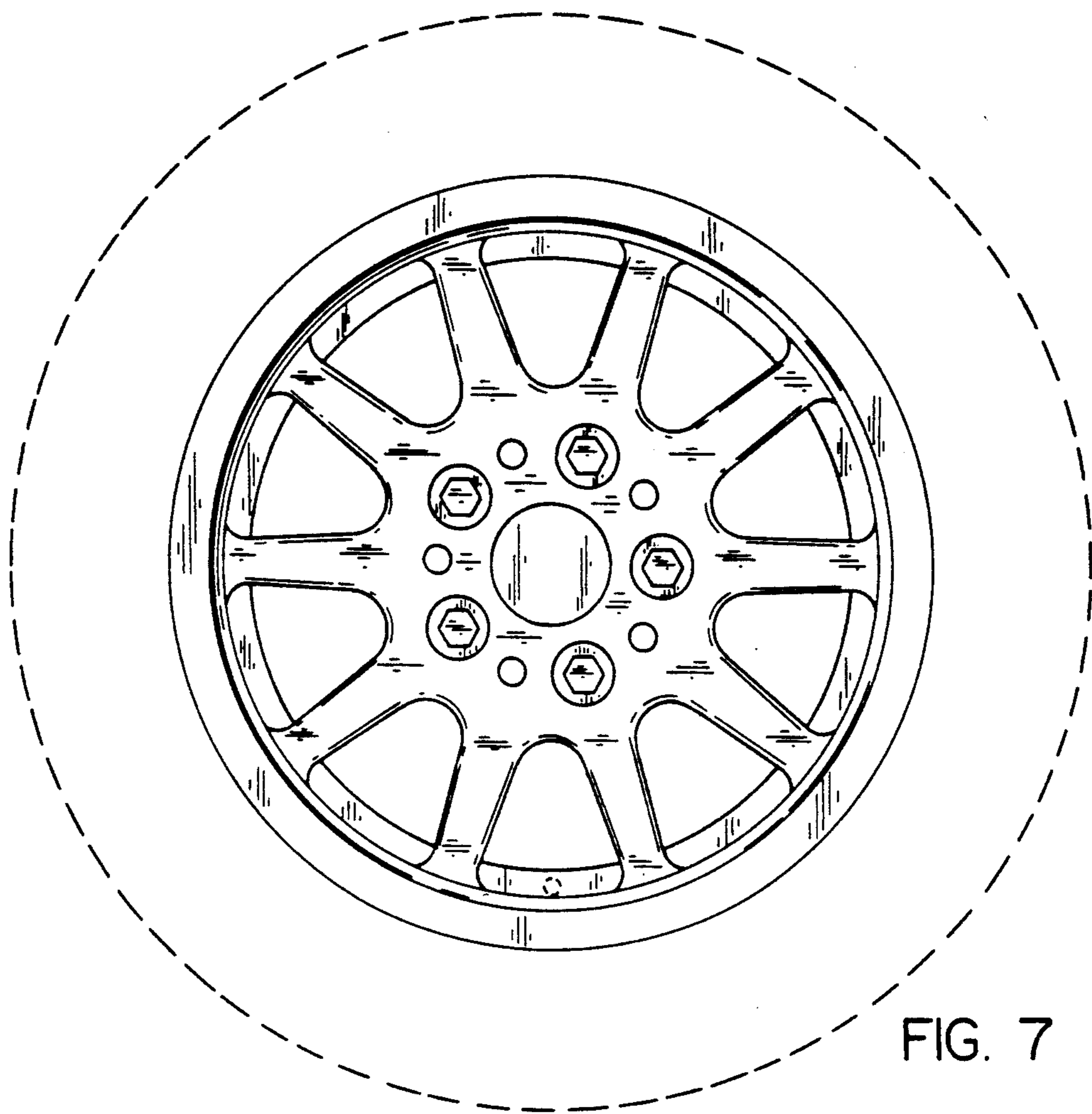

FIG. 7

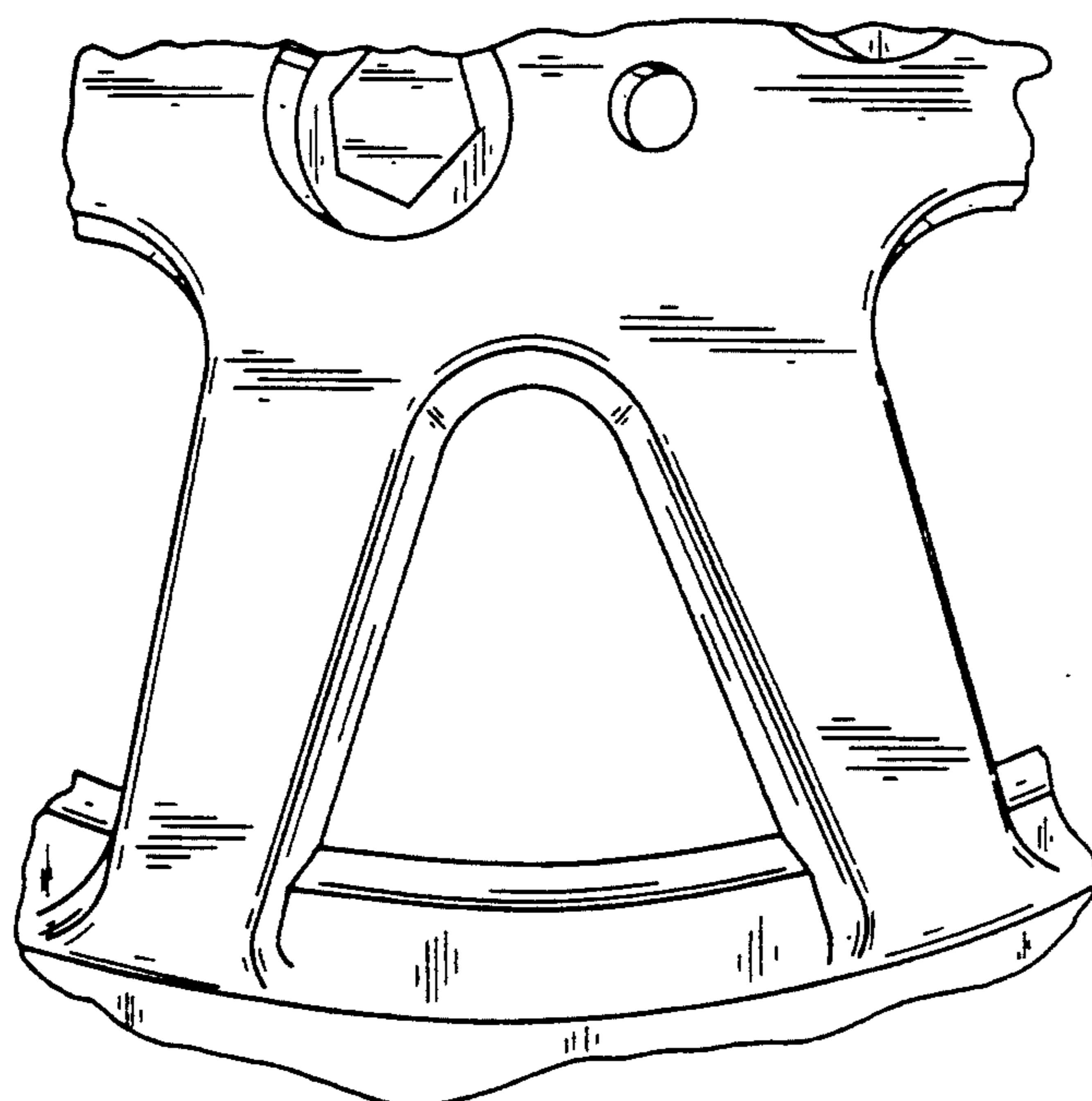

FIG. 8

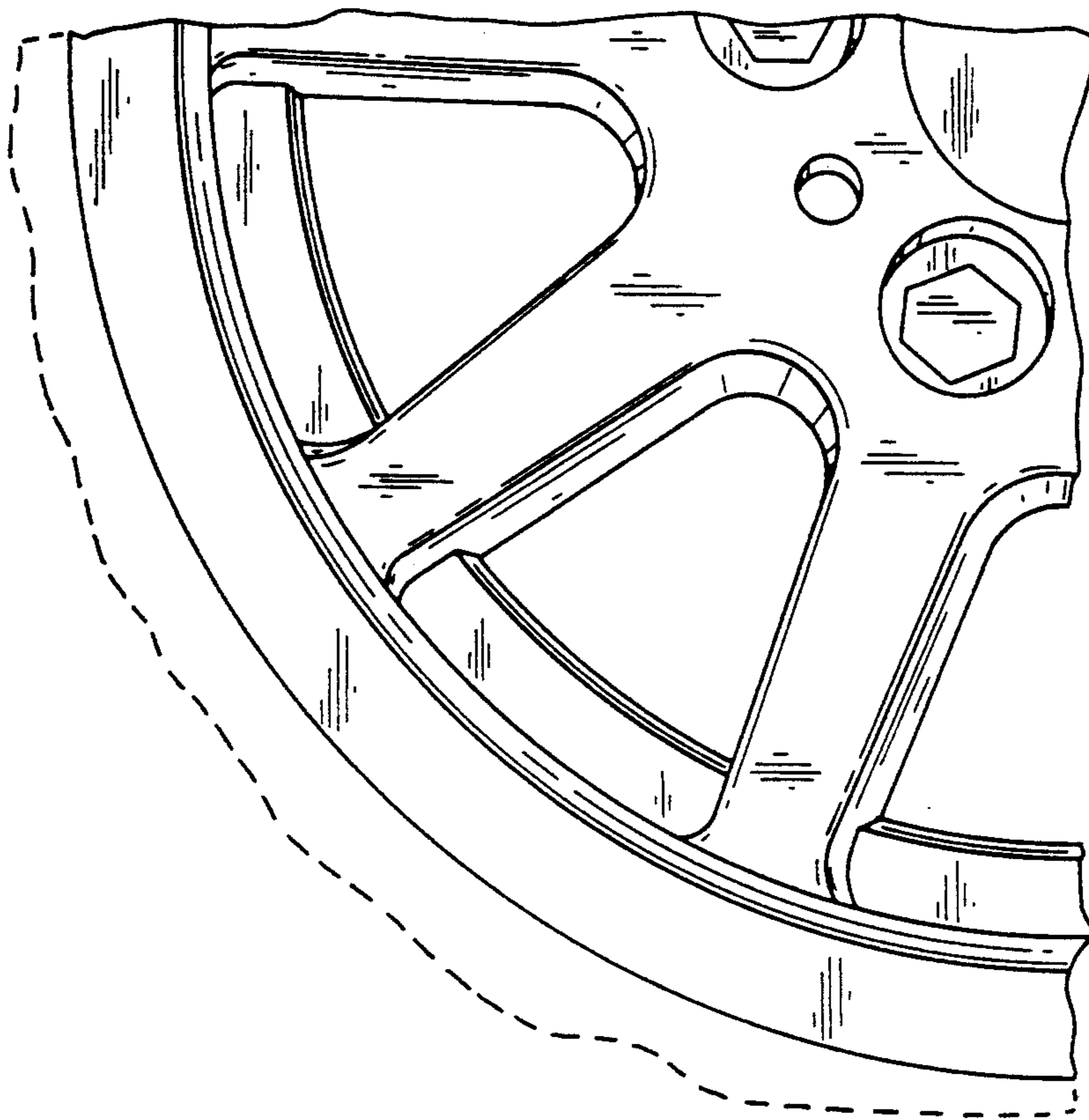

FIG. 9

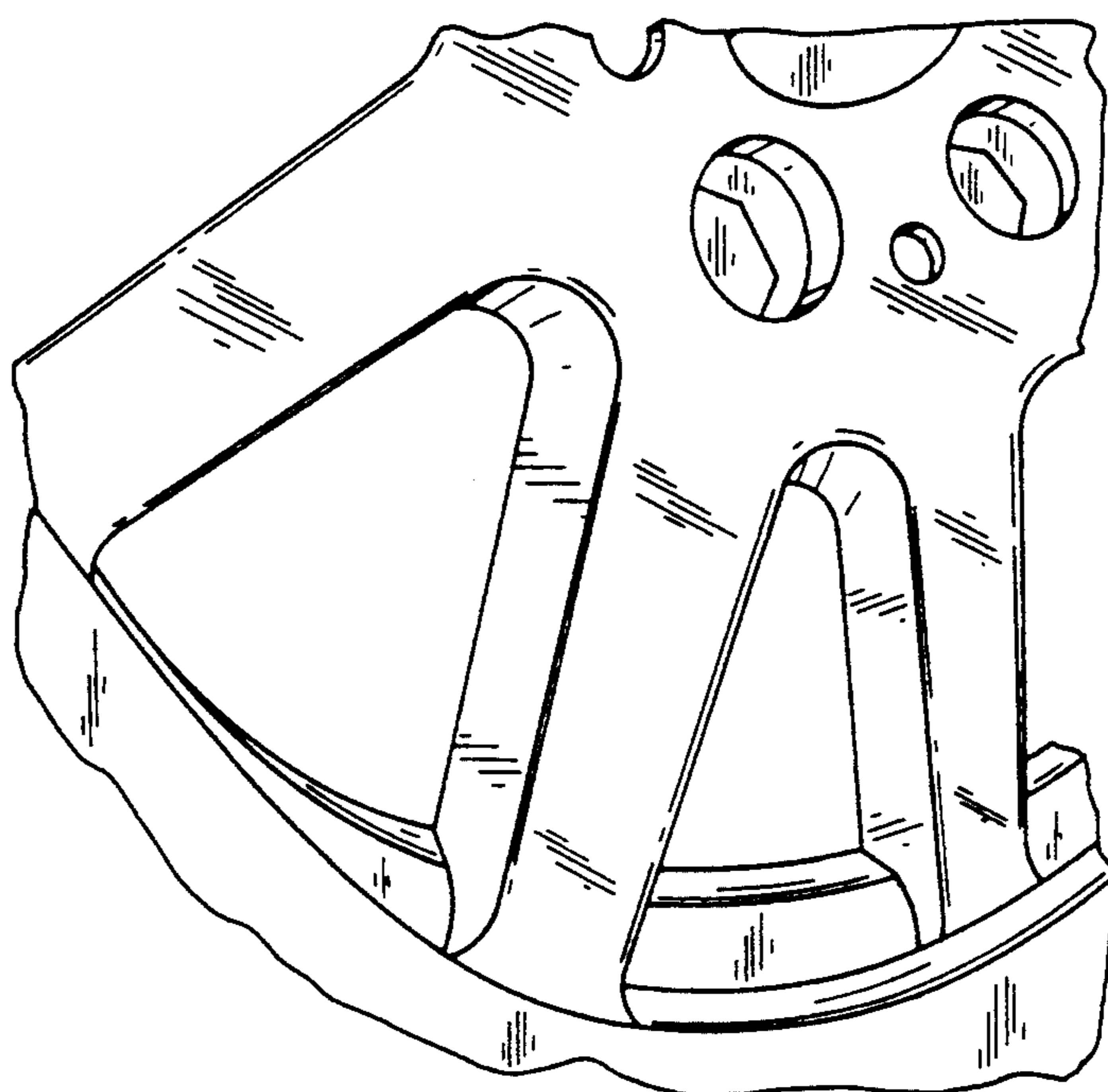

FIG. 10

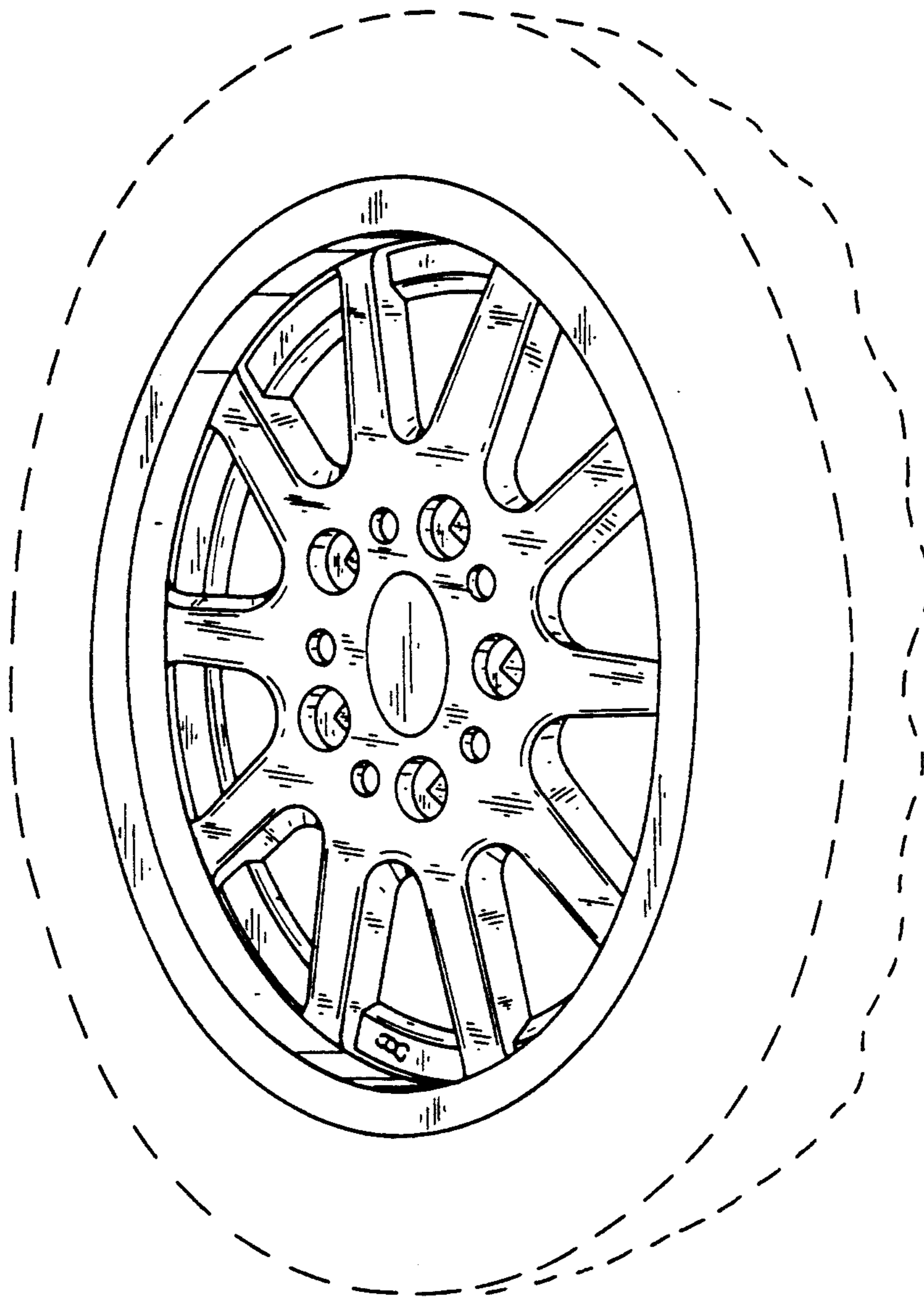

FIG. II