



US00D344919S

# United States Patent [19]

[11] Patent Number: **Des. 344,919**

**Konte**

[45] Date of Patent: **\*\* Mar. 8, 1994**

[54] **TRUCK BOX RAIL**

[76] Inventor: **Ignac Konte**, 3349 McGinnis Rd., Westbank, B.C., Canada, V0H 2A0

[\*\*] Term: **14 Years**

[21] Appl. No.: **764,390**

[22] Filed: **Sep. 23, 1991**

[30] **Foreign Application Priority Data**

Apr. 30, 1991 [CA] Canada ..... 30-04-91-4

[52] U.S. Cl. .... **D12/400**

[58] Field of Search ..... 410/104, 105, 106, 108, 410/110, 115, 118; 296/40, 41, 43, 3, 10; D12/155, 98; D25/119, 123, 125

[56] **References Cited**

**U.S. PATENT DOCUMENTS**

D. 311,714	10/1990	Koezle	.....	D12/155
2,688,289	9/1954	Sterling	.....	105/369
2,743,684	5/1956	Elsner	.....	105/369
2,859,710	11/1958	Elsner	.....	105/369
4,020,770	5/1977	McLennan	.....	105/402
4,248,588	2/1981	Lechner	.....	410/104
4,496,271	1/1985	Spinosa et al.	.....	410/105

**FOREIGN PATENT DOCUMENTS**

585888 10/1959 Canada .

*Primary Examiner*—James M. Gandy  
*Attorney, Agent, or Firm*—Merchant Gould Smith Edell Welter & Schmidt

[57] **CLAIM**

The ornamental design for a truck box rail, as shown and described.

**DESCRIPTION**

FIG. 1 is a perspective view of a truck box rail showing my new design;  
 FIG. 2 is an end elevation view thereof, the opposite end being a mirror image of that shown;  
 FIG. 3 is a top plan view thereof;  
 FIG. 4 is a bottom plan view thereof;  
 FIG. 5 is an end elevation view of a truck box rail showing a second embodiment of my new design, the opposite end being a mirror image of that shown;  
 FIG. 6 is a top plan view of FIG. 5;  
 FIG. 7 is a bottom plan view of FIG. 5;  
 FIG. 8 is an end elevation view of a truck box rail showing a third embodiment of my new design, the opposite end being a mirror image of that shown;  
 FIG. 9 is a top plan view of FIG. 8;  
 FIG. 10 is a bottom plan view of FIG. 8;  
 FIG. 11 is an end elevation view of a truck box rail showing a fourth embodiment of my new design, the opposite end being a mirror image of that shown, it being understood that the downwardly extending right side surface is flat and unornamented;  
 FIG. 12 is a top plan view of FIG. 11; and,  
 FIG. 13 is a bottom plan view of FIG. 11.

A portion of the four embodiments of the truck box rail has been broken away in FIGS. 1, 3, 4, 6, 7, 9, 10, 12 and 13 of the drawing to indicate indeterminate length.

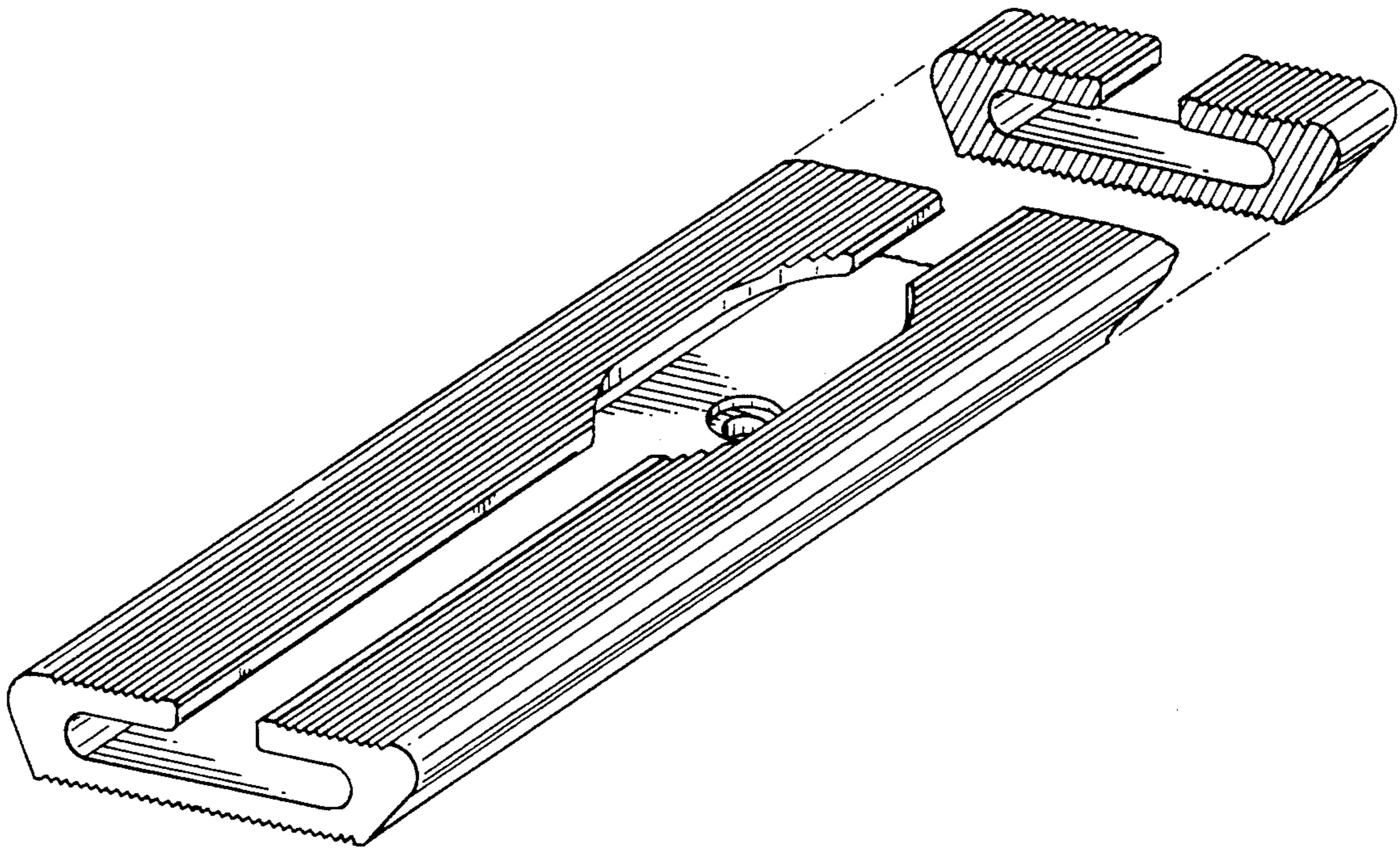



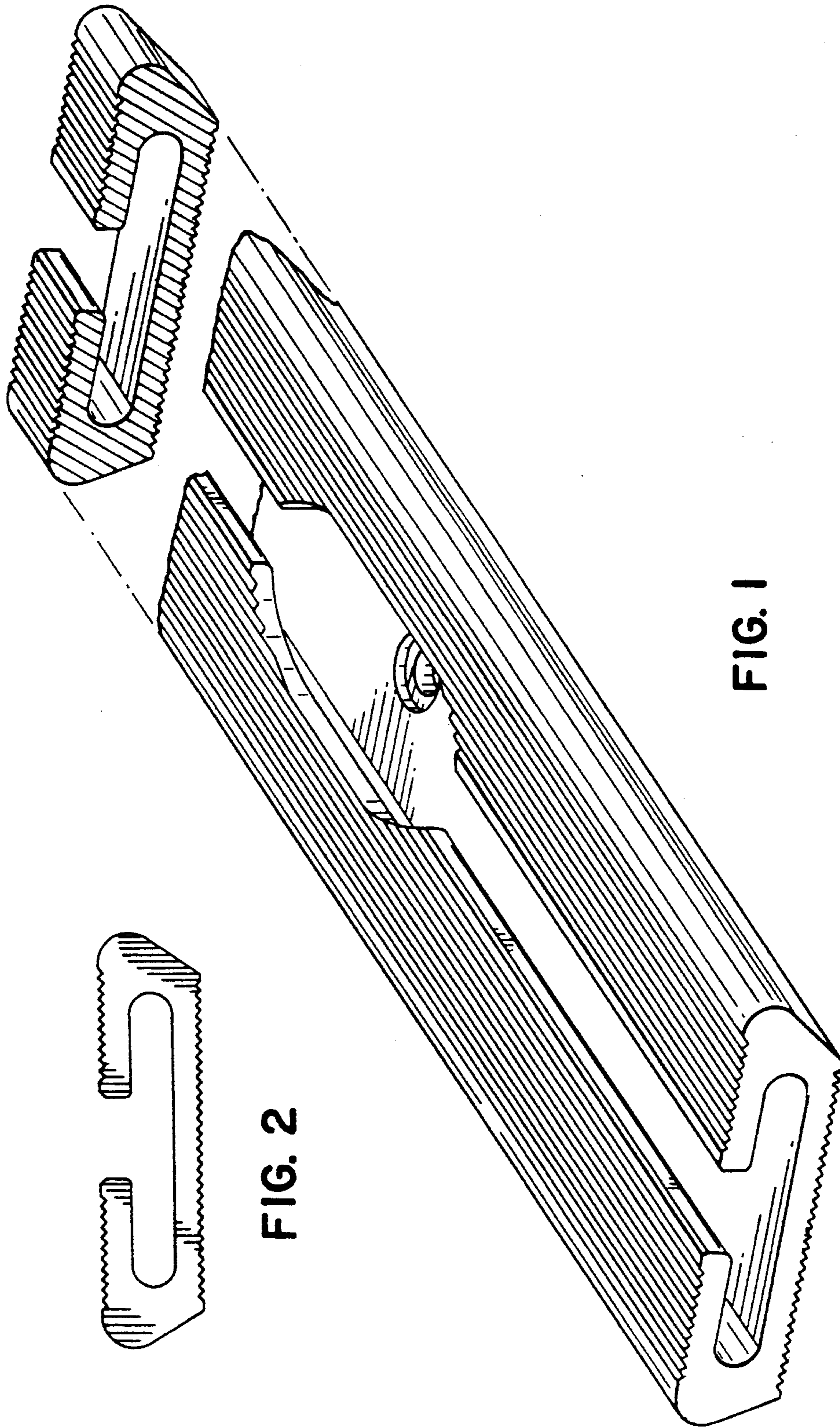

FIG. 2

FIG. 1

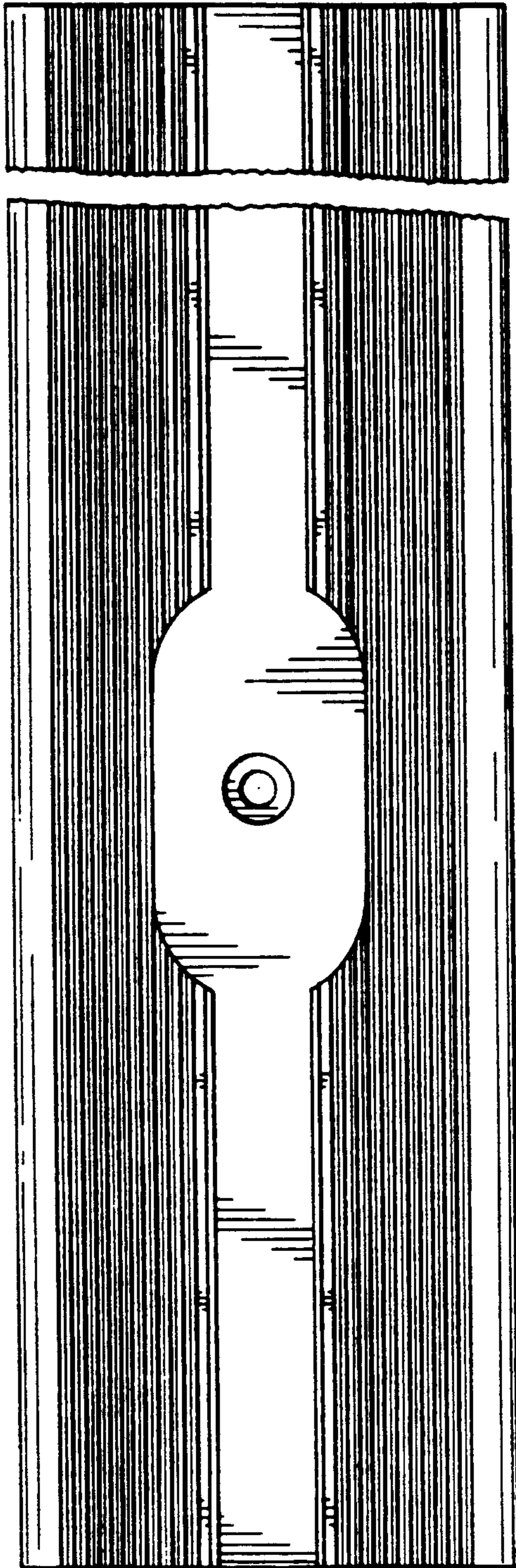

FIG. 3

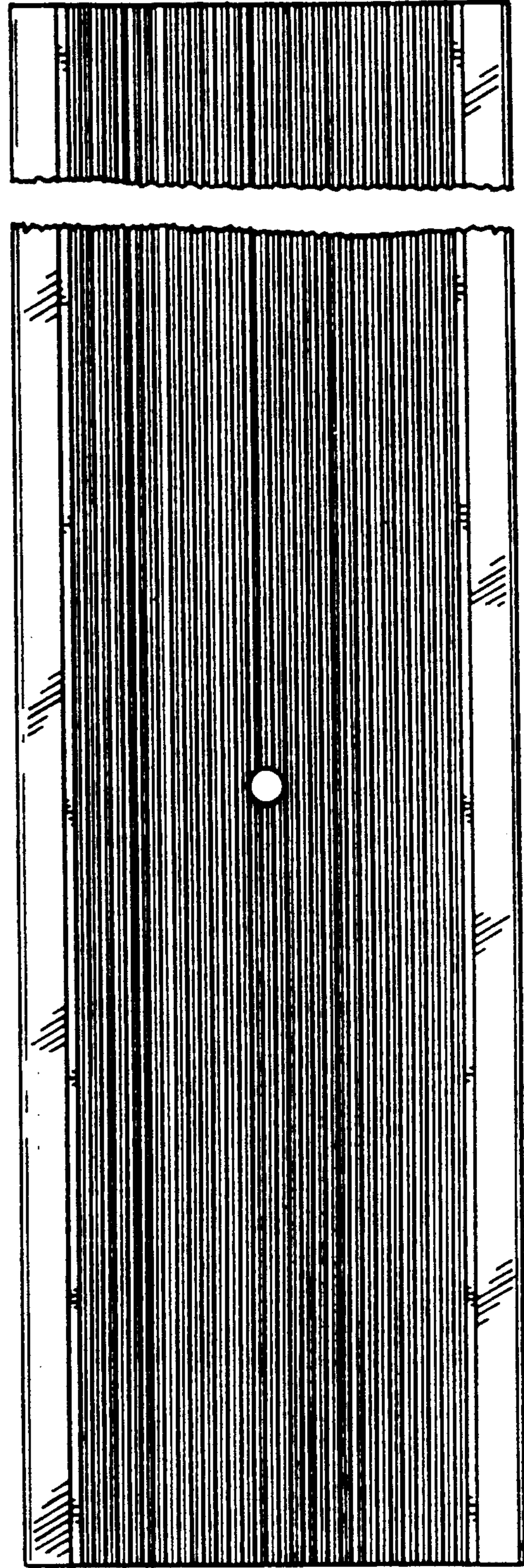

FIG. 4



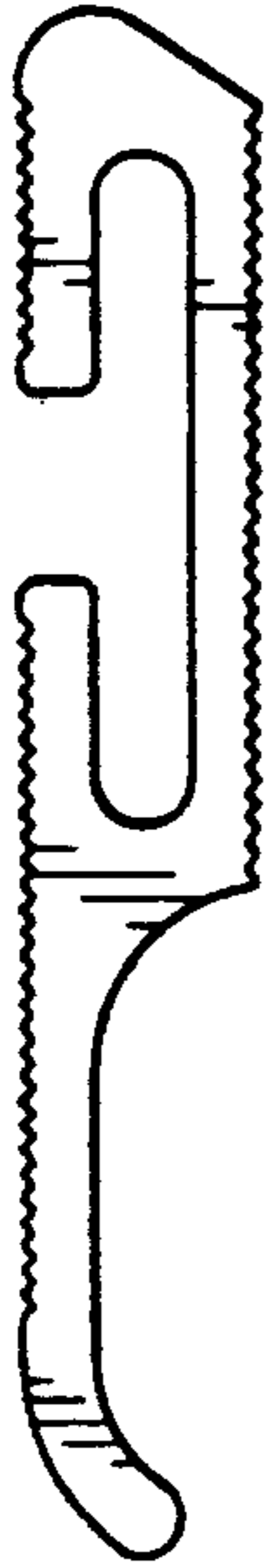

FIG. 5

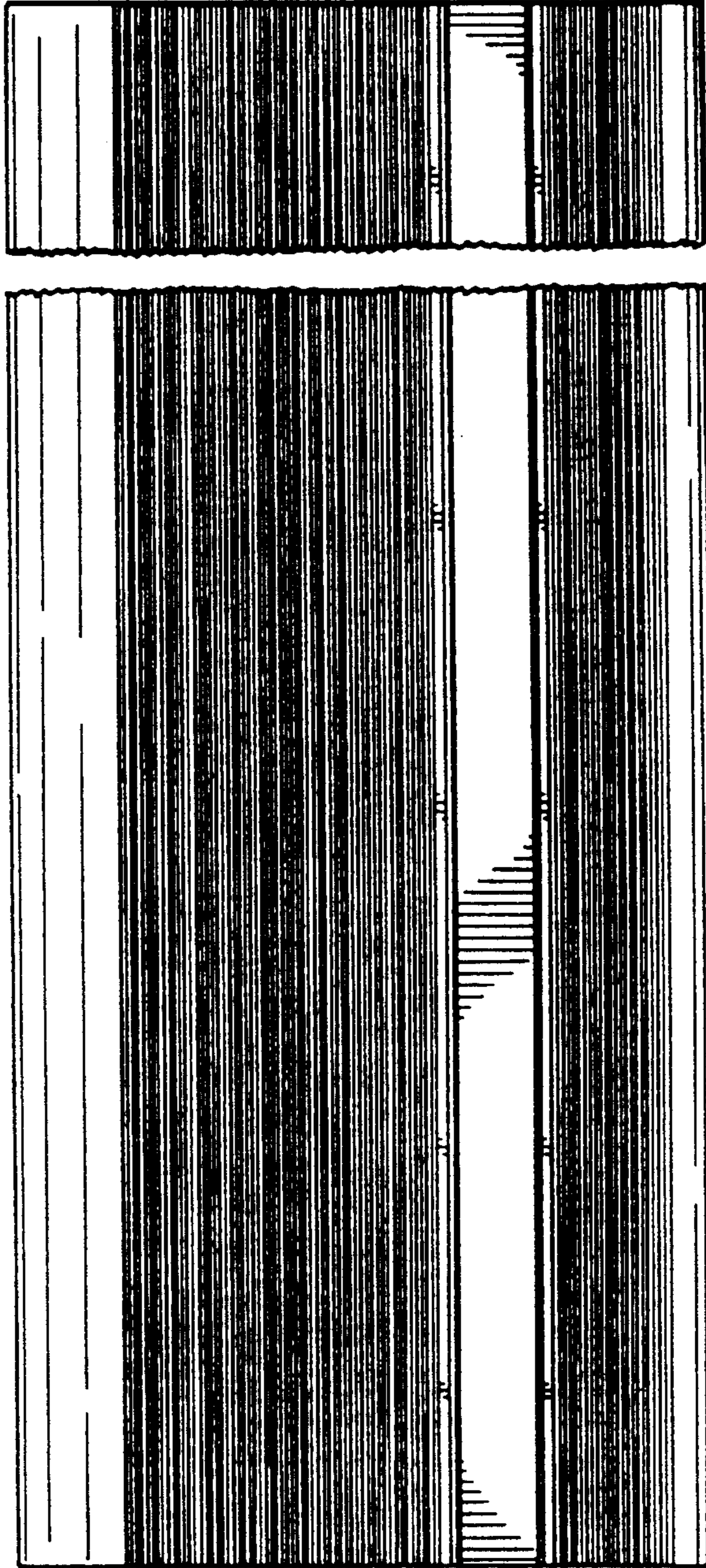

FIG. 6

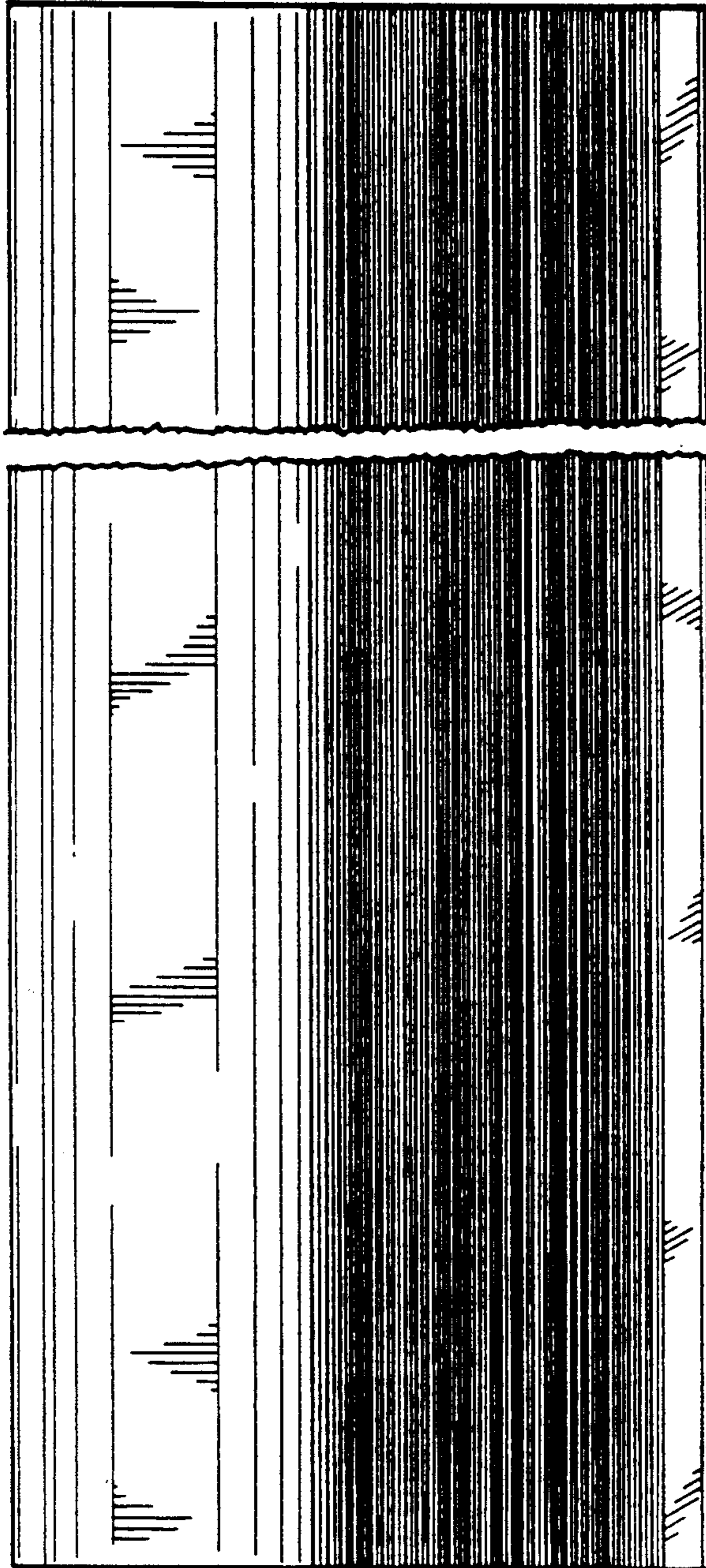

FIG. 7

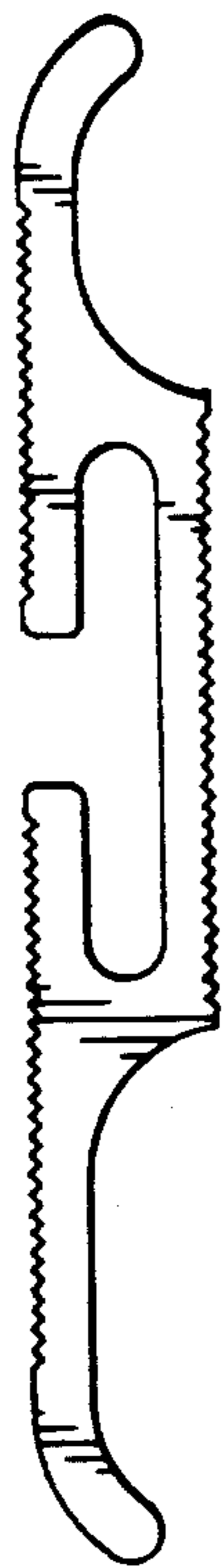

FIG. 8

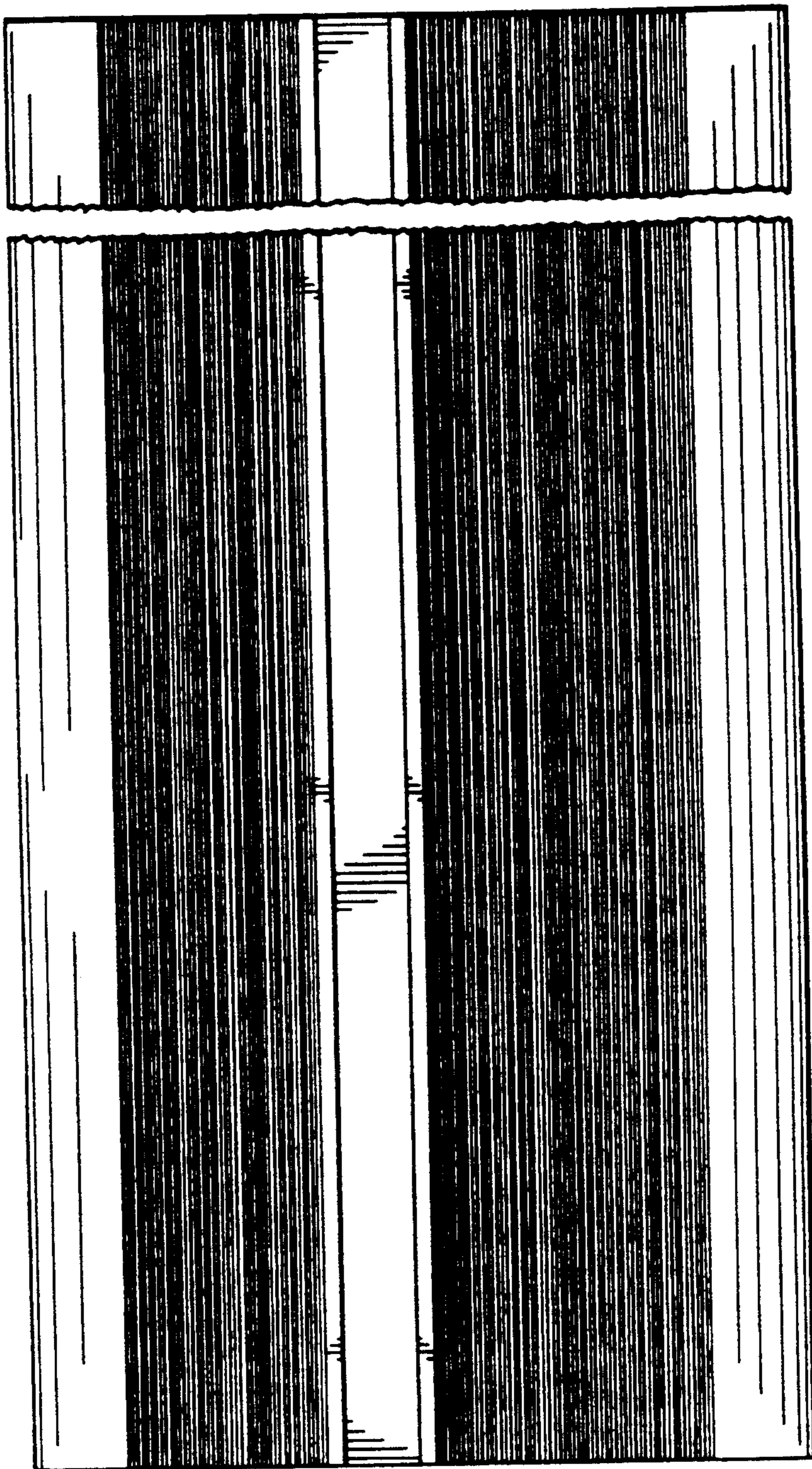

FIG. 9



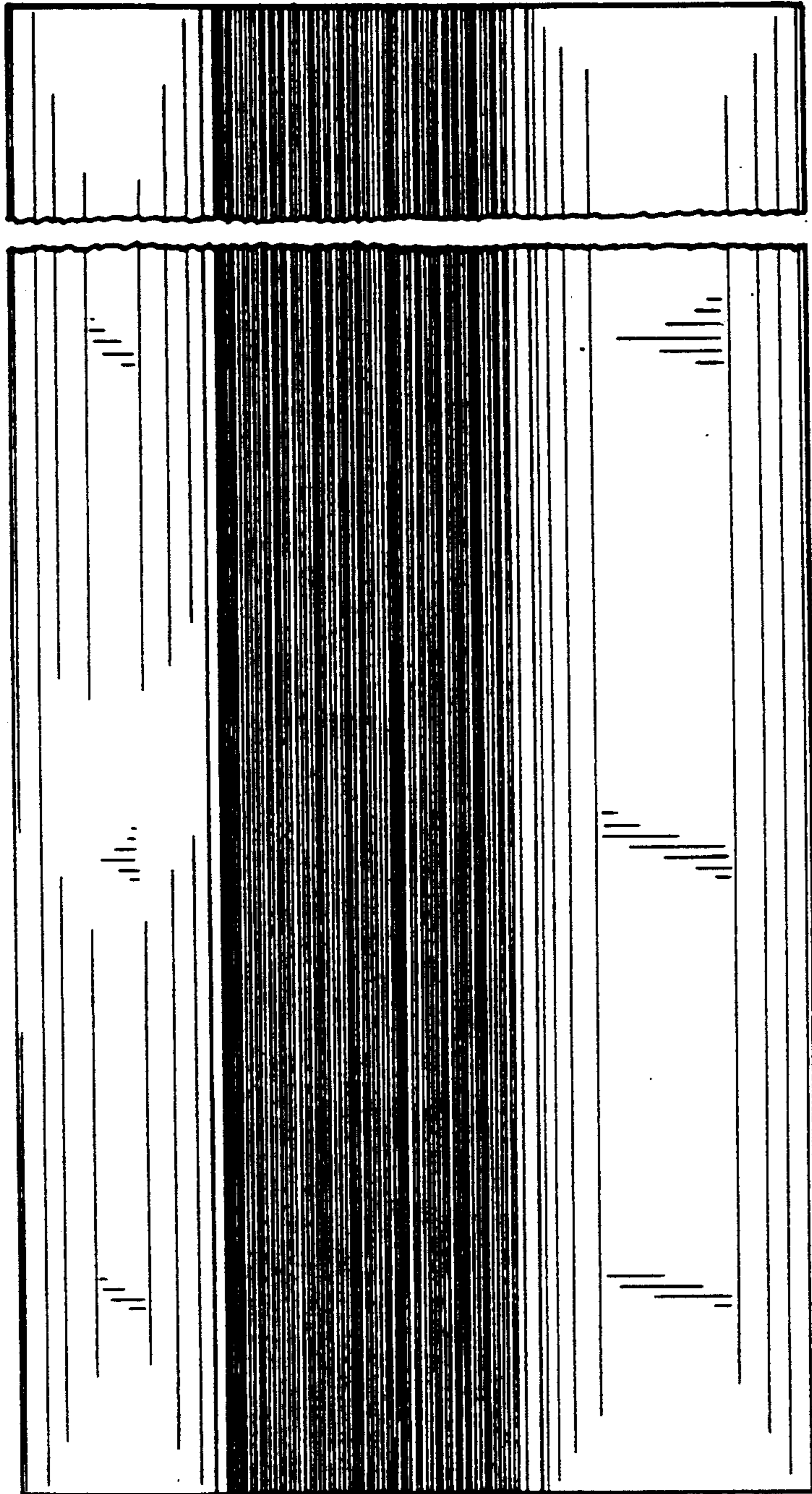

FIG. 10

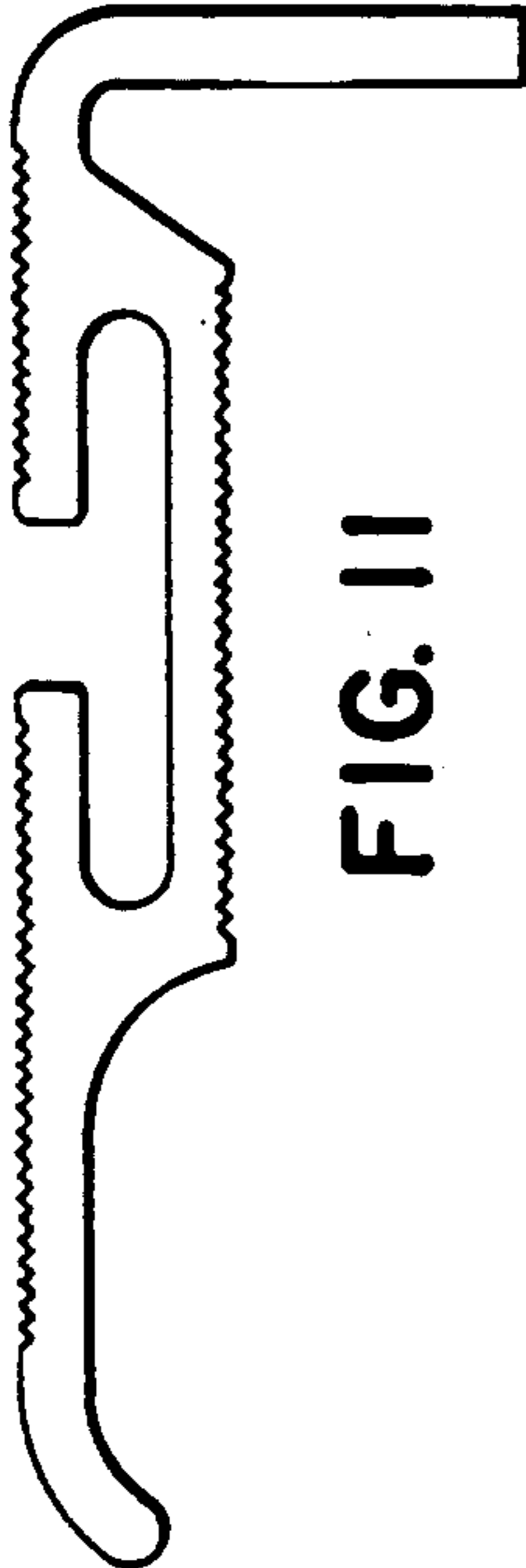

FIG. 11

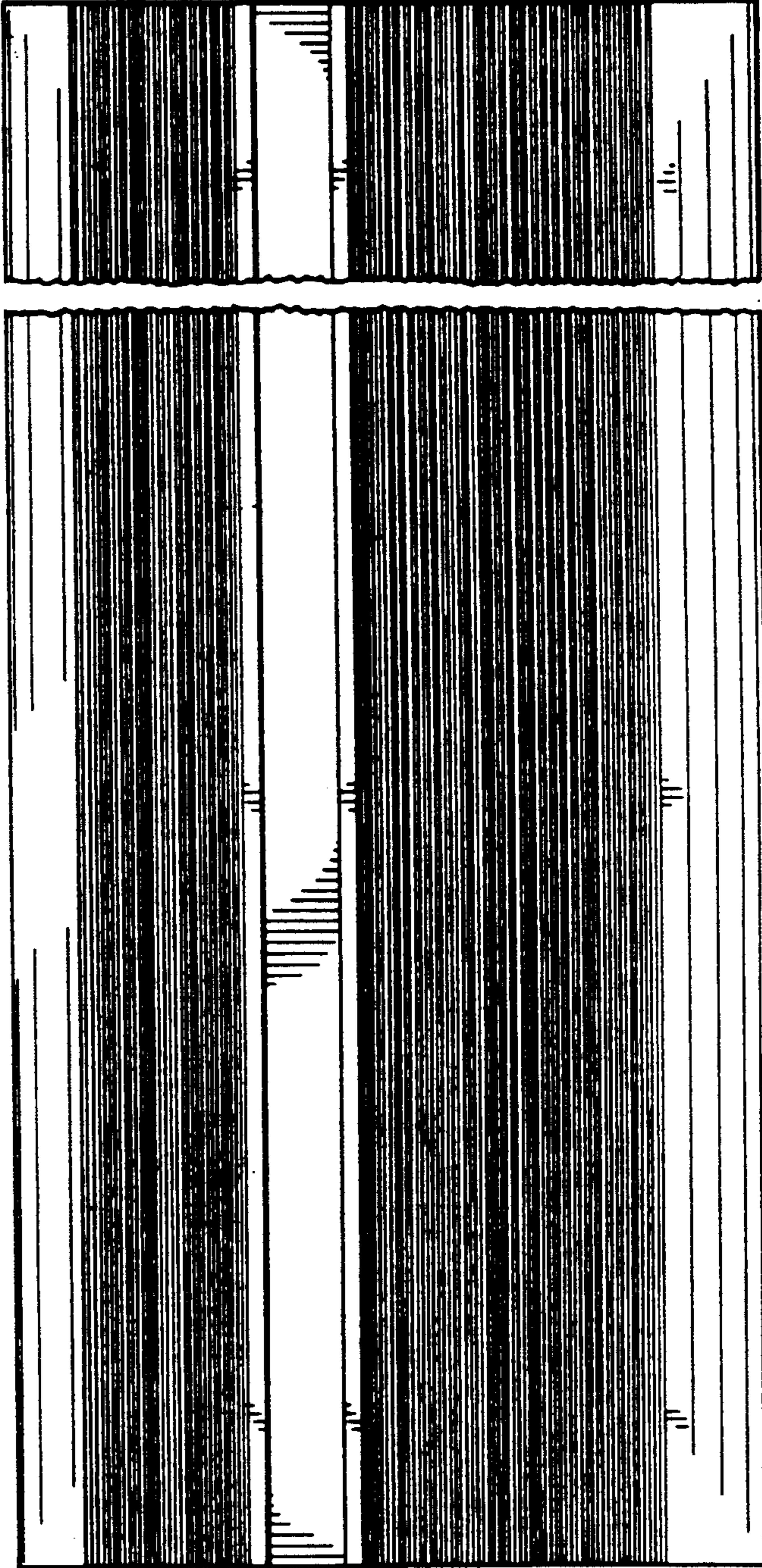

FIG. 12



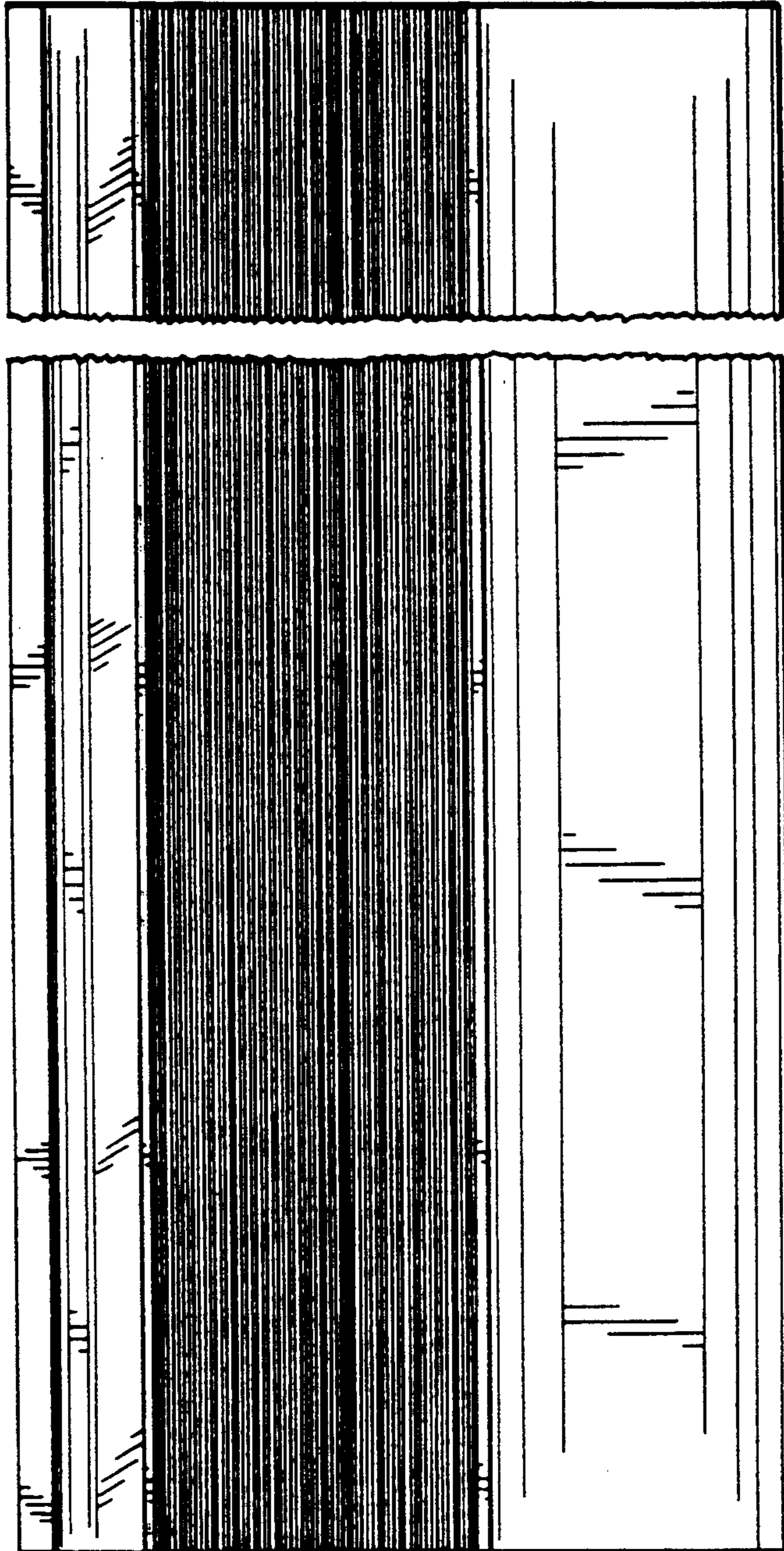

FIG. 13