



US00D344701S

**United States Patent** [19]  
**Church**

[11] **Patent Number: Des. 344,701**  
[45] **Date of Patent: \*\* Mar. 1, 1994**

[54] **CHILD'S CARRIAGE**

[57] **CLAIM**

[75] **Inventor: Graham Church, Moulton, Great Britain**

The ornamental design for a child's carriage, as shown and described.

[73] **Assignee: Maclaren Limited, Northampton, England**

**DESCRIPTION**

[\*\*] **Term: 14 Years**

FIG. 1 is a perspective view showing the front, right side, and top of the frame of the child's carriage embodying my new design;

[21] **Appl. No.: 151**

FIG. 2 is a left side view thereof;

[22] **Filed: Oct. 1, 1992**

FIG. 3 is a top view thereof;

[52] **U.S. Cl. .... D12/129**

FIG. 4 is a left side view thereof folded down;

[58] **Field of Search ..... 280/650, 30, 643, 648, 280/642; 297/379; 296/37.4, 35.4; D12/128, 129**

FIG. 5 is a front view thereof;

FIG. 6 is a rear view thereof;

FIG. 7 is a front view of the body thereof;

FIG. 8 is a rear view of the body;

FIG. 9 is a right side view of the body, the left side view being mirror symmetrical thereto;

FIG. 10 is a right side view of the child's carriage, the left side view being mirror symmetrical thereto;

FIG. 11 is a front view thereof;

FIG. 12 is a rear view thereof;

FIG. 13 is a right side view of the child's carriage with a different body according to another embodiment of my design, the left side view being mirror symmetrical thereto; and,

FIG. 14 is a right side view of the child's carriage with still another different body according to a further embodiment of my design, the left side view being mirror symmetrical thereto.

The sole difference among the first, second (FIG. 13), and third (FIG. 14) embodiment being in the different configuration of the carriage body.

[56] **References Cited**

**U.S. PATENT DOCUMENTS**

5,201,535 4/1993 Kato et al. .... 280/650

**FOREIGN PATENT DOCUMENTS**

483042 4/1992 European Pat. Off. .... 280/650

*Primary Examiner*—Kay H. Chin

*Attorney, Agent, or Firm*—Herbert Dubno; Ronald Lianides

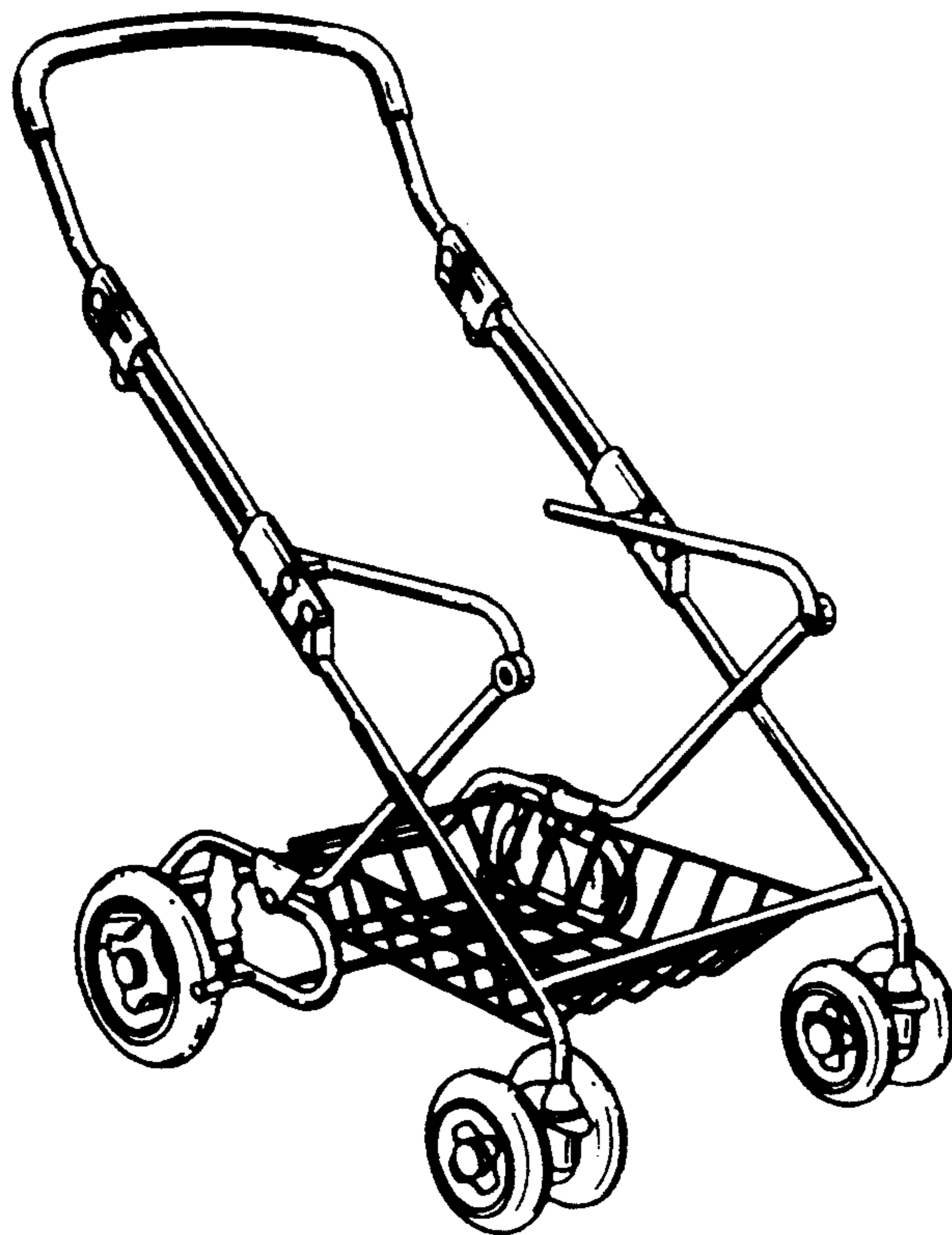

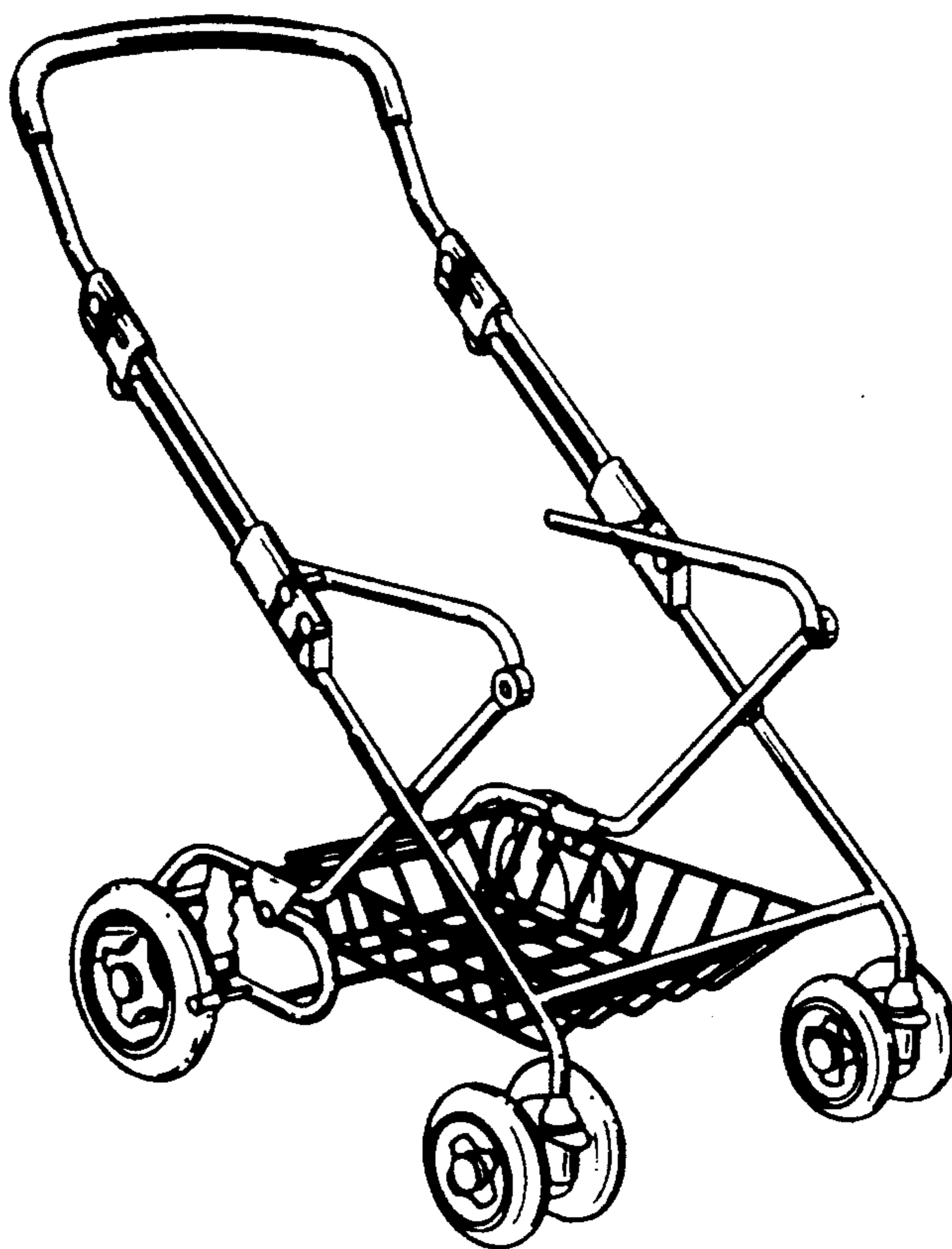

*Fig.1.*

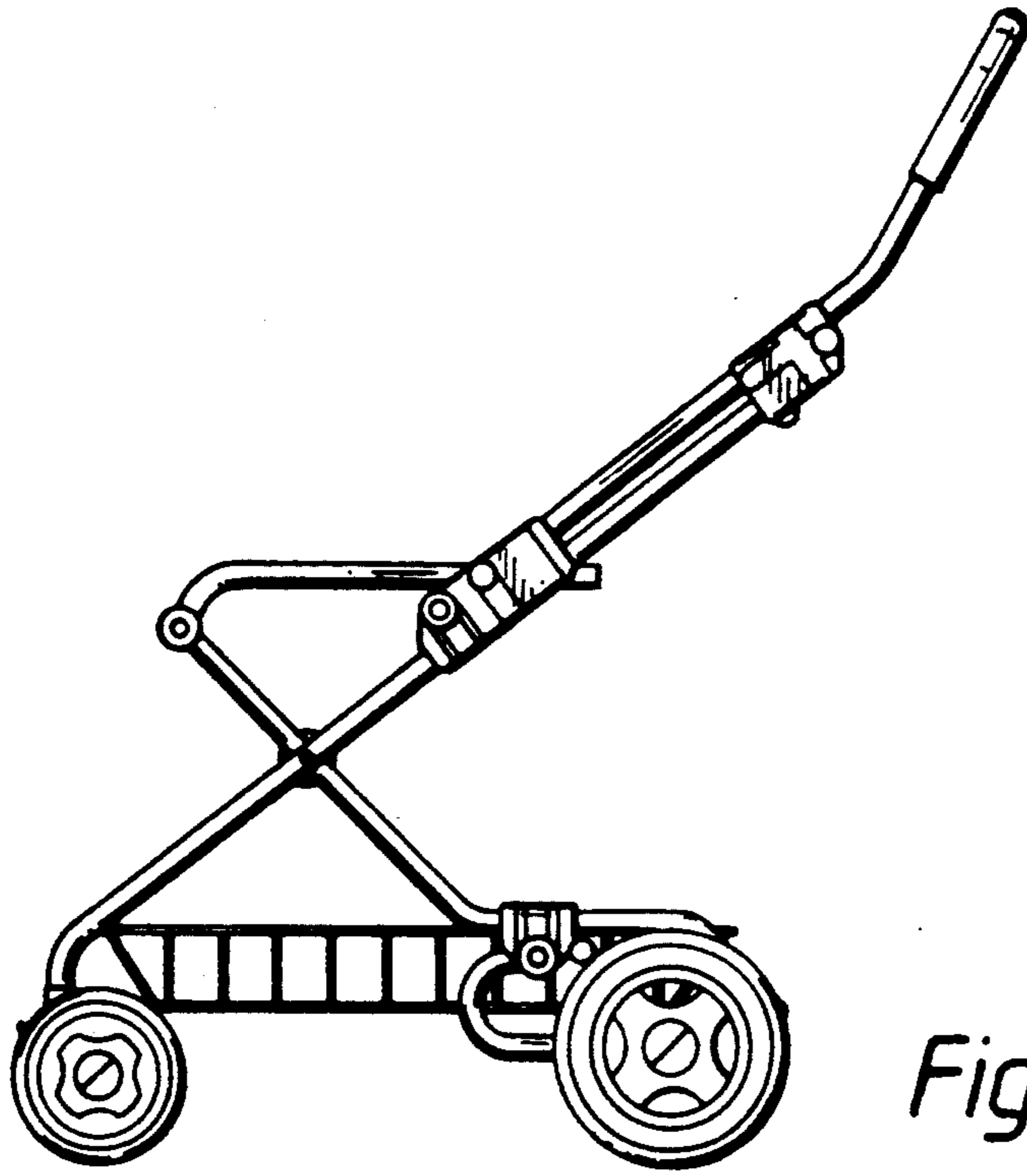

Fig. 2.

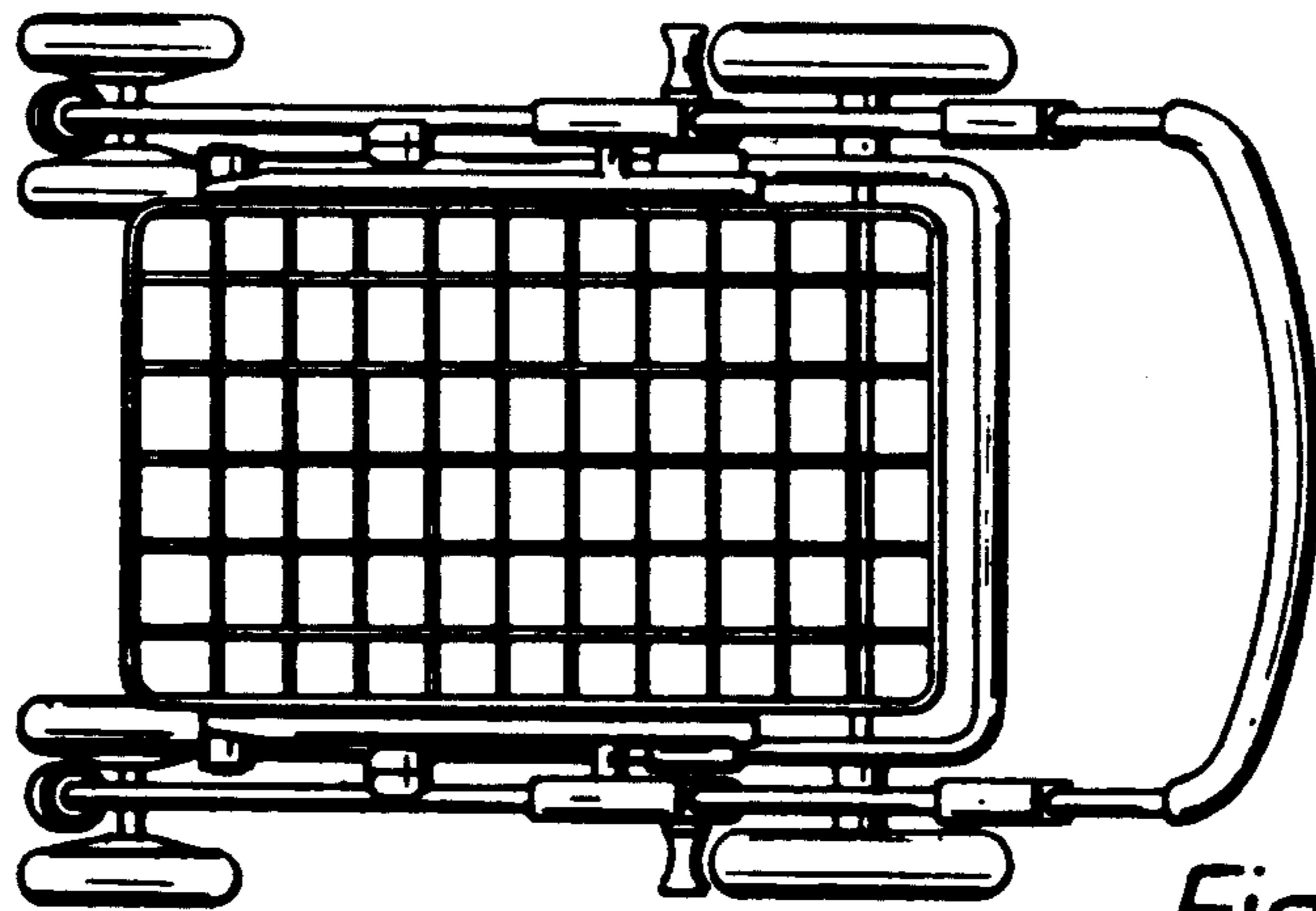

Fig. 3.

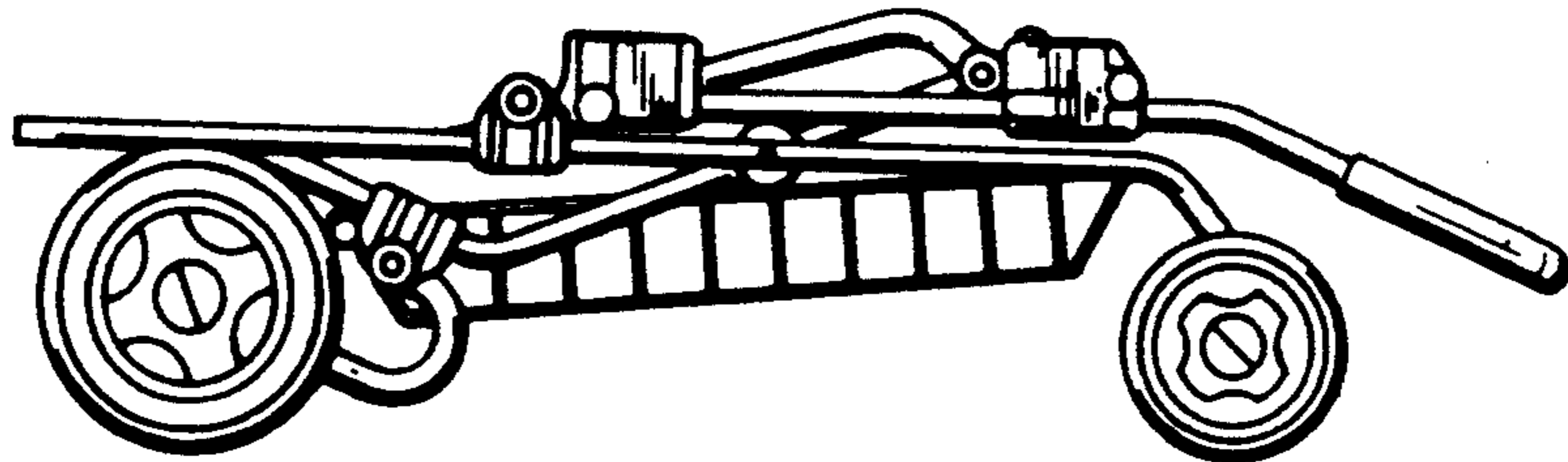
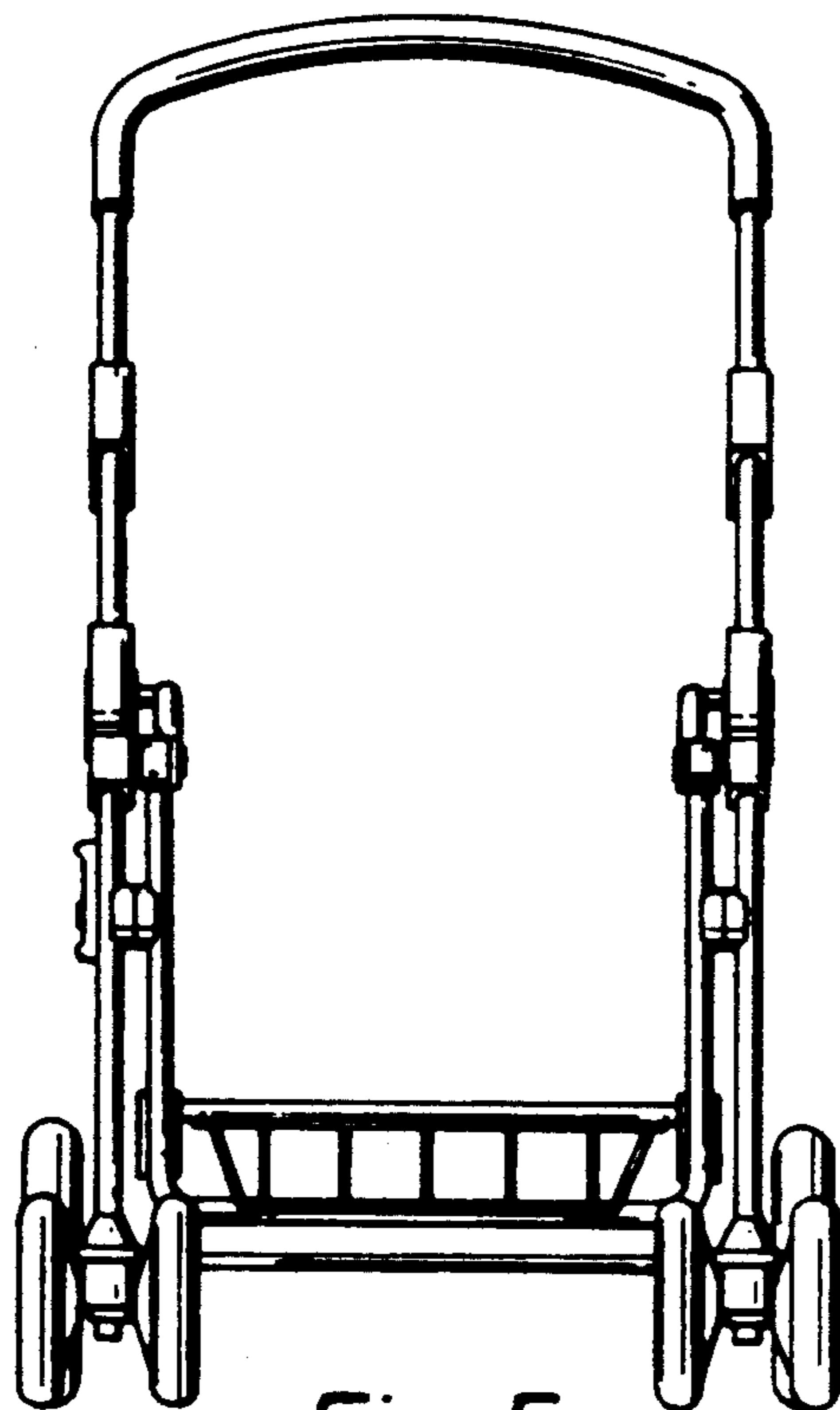
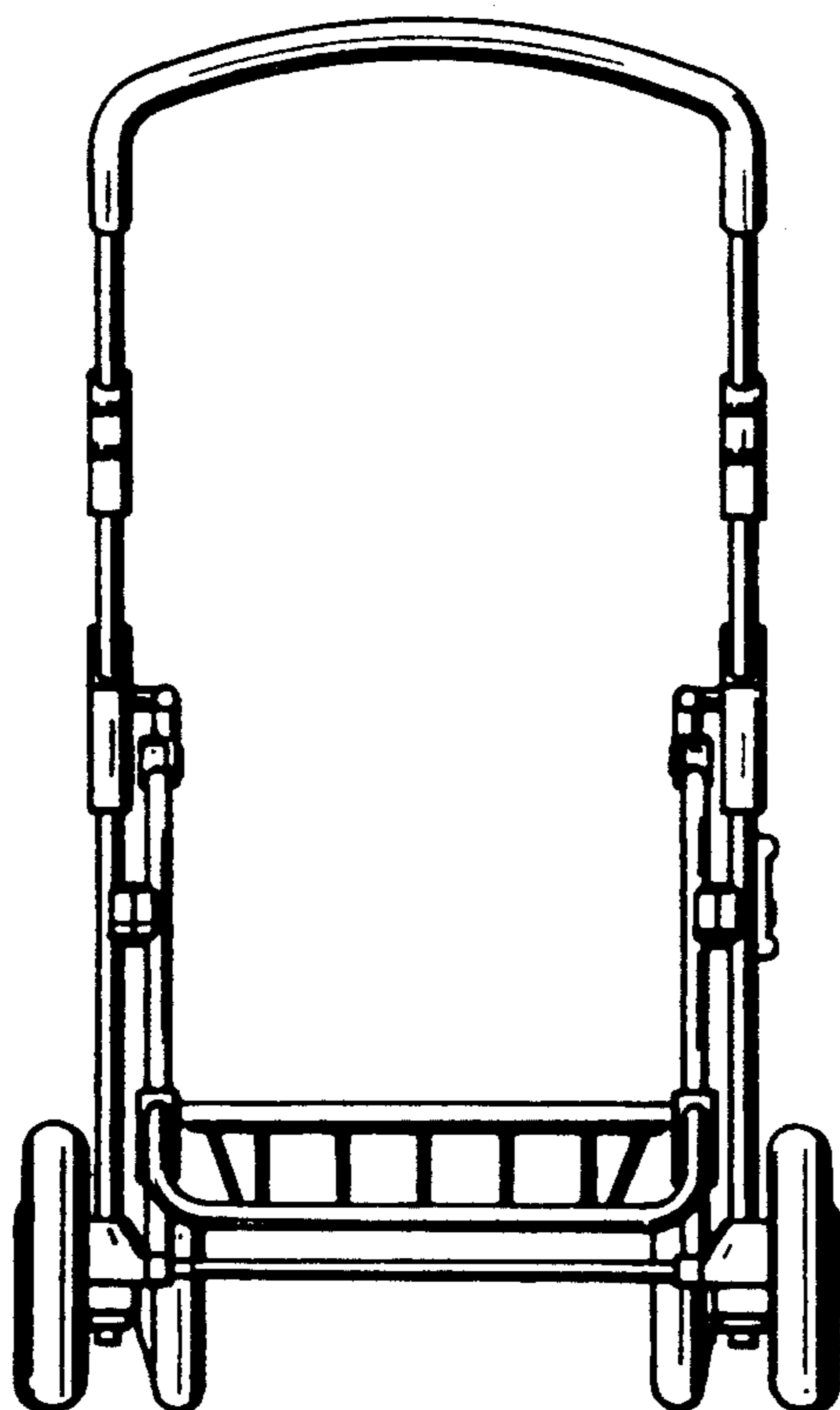

Fig. 4.



*Fig. 5.*



*Fig. 6.*

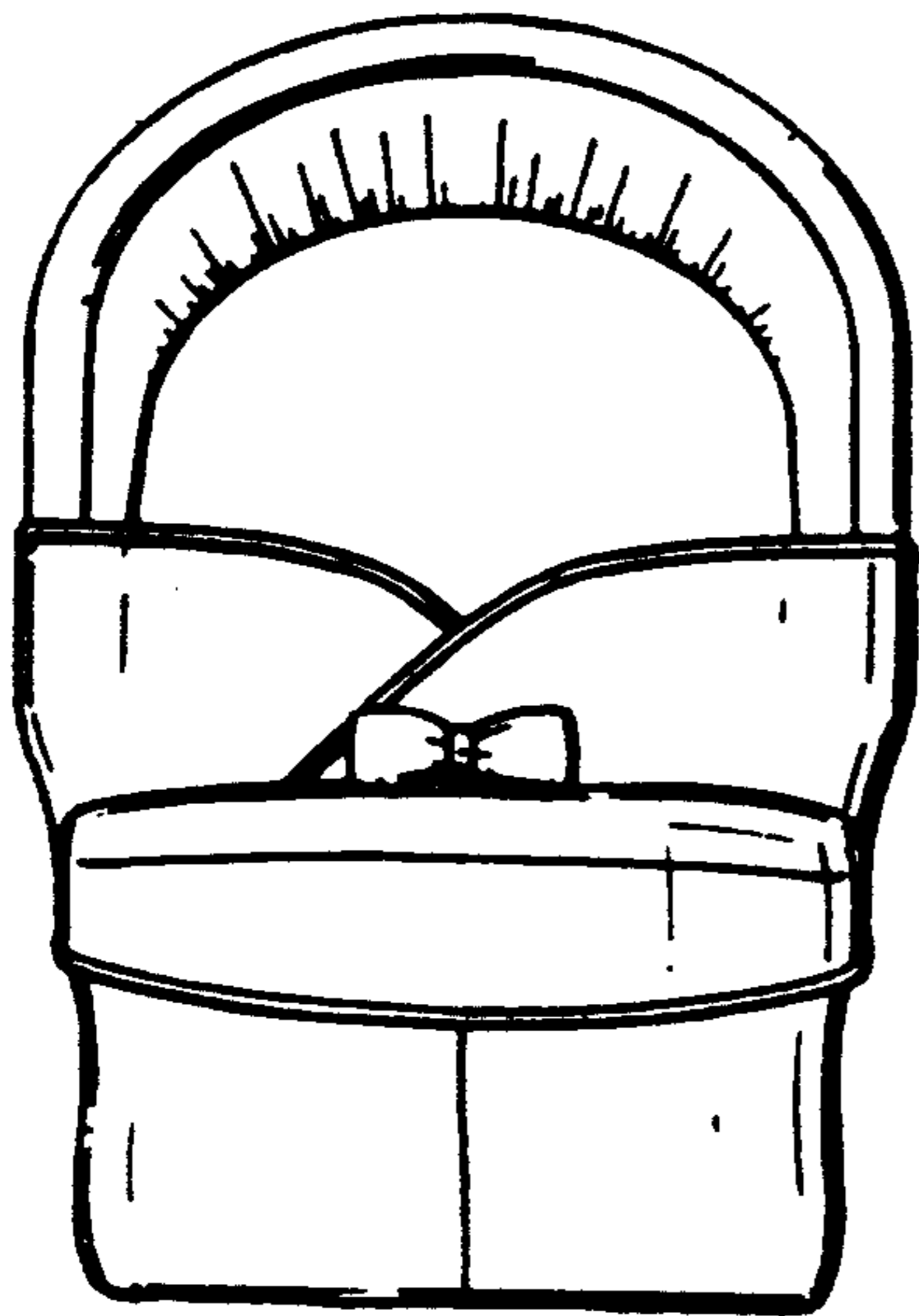

*Fig. 7.*

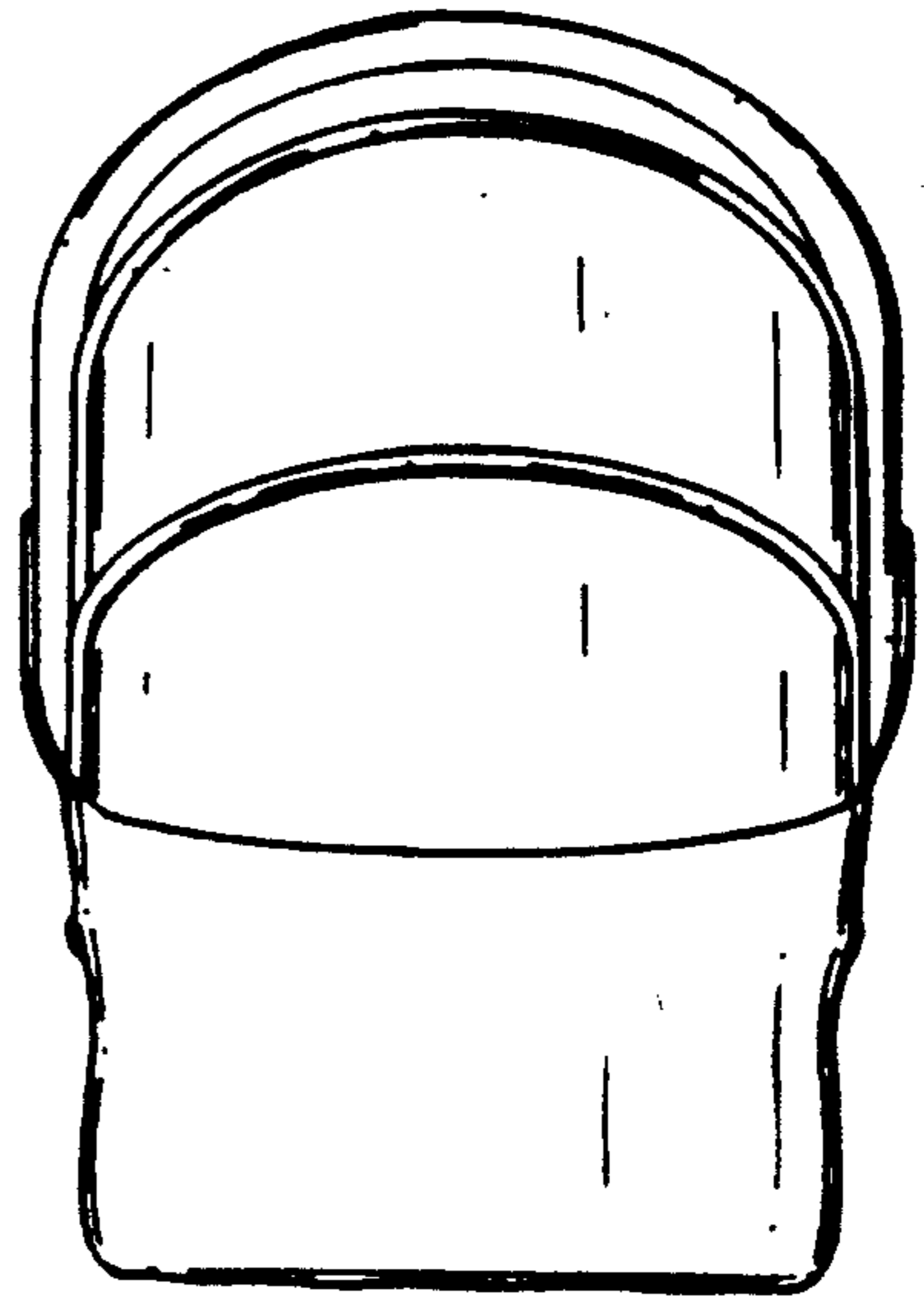

*Fig. 8.*

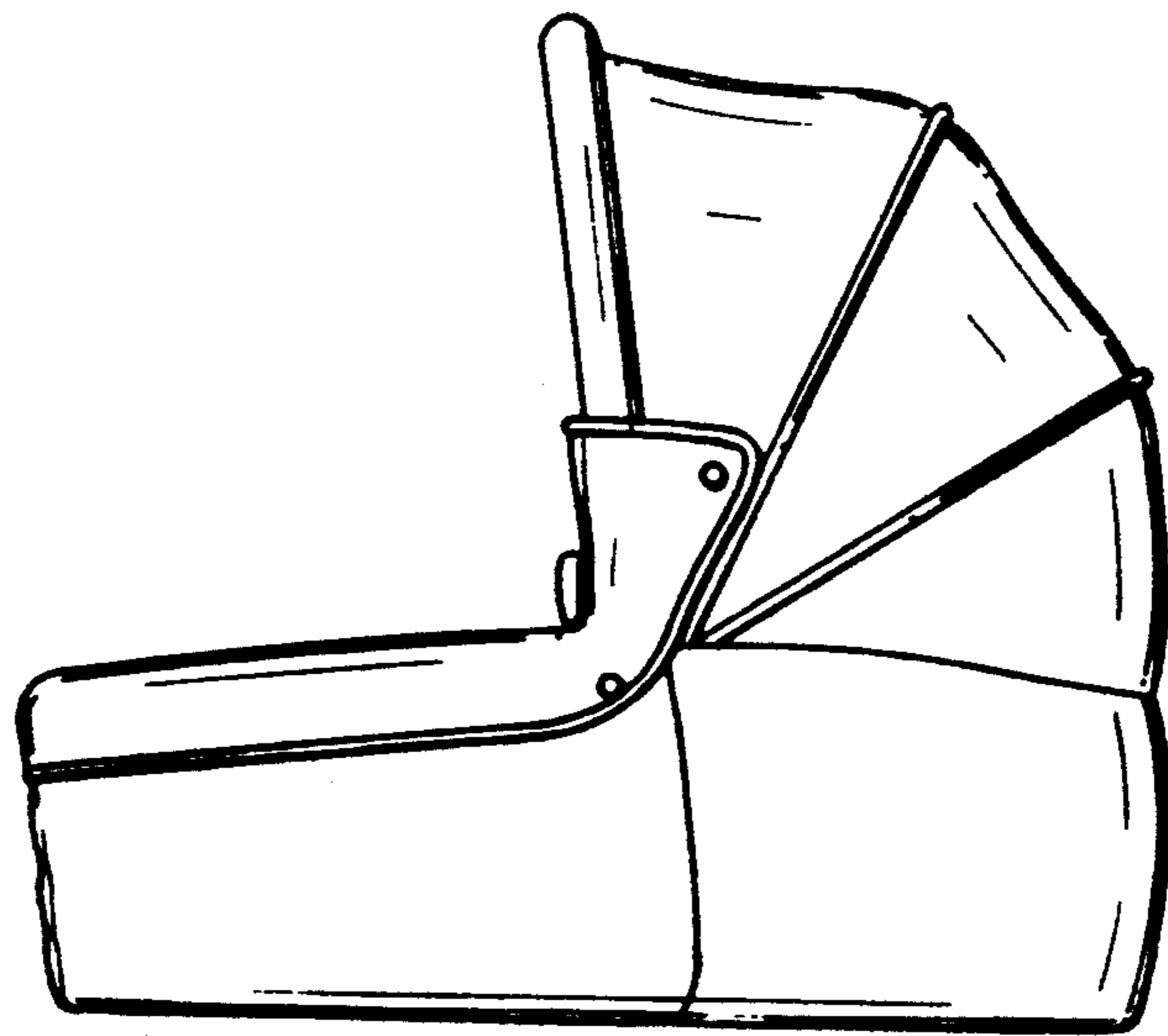

*Fig. 9.*

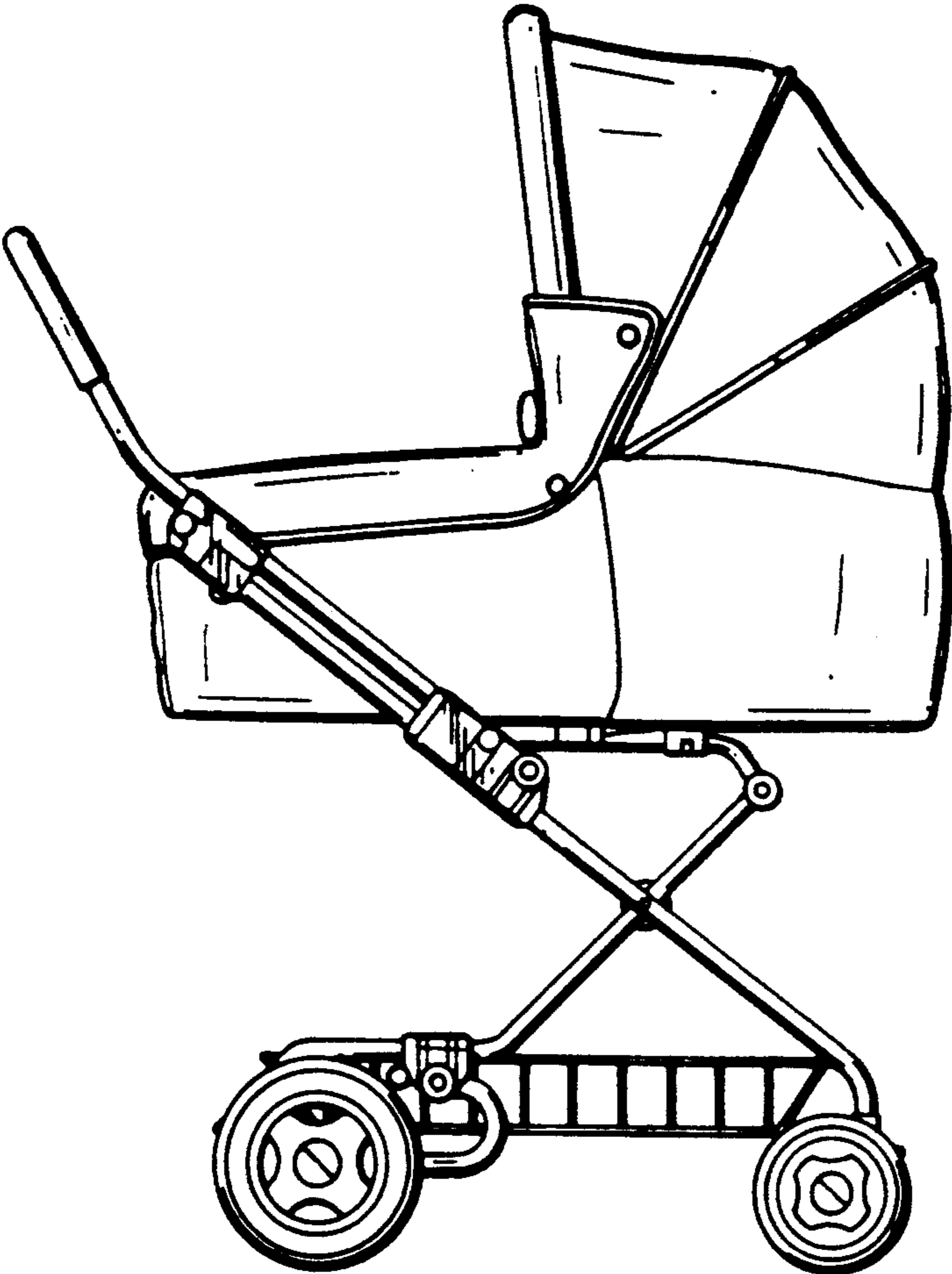

*Fig. 10.*

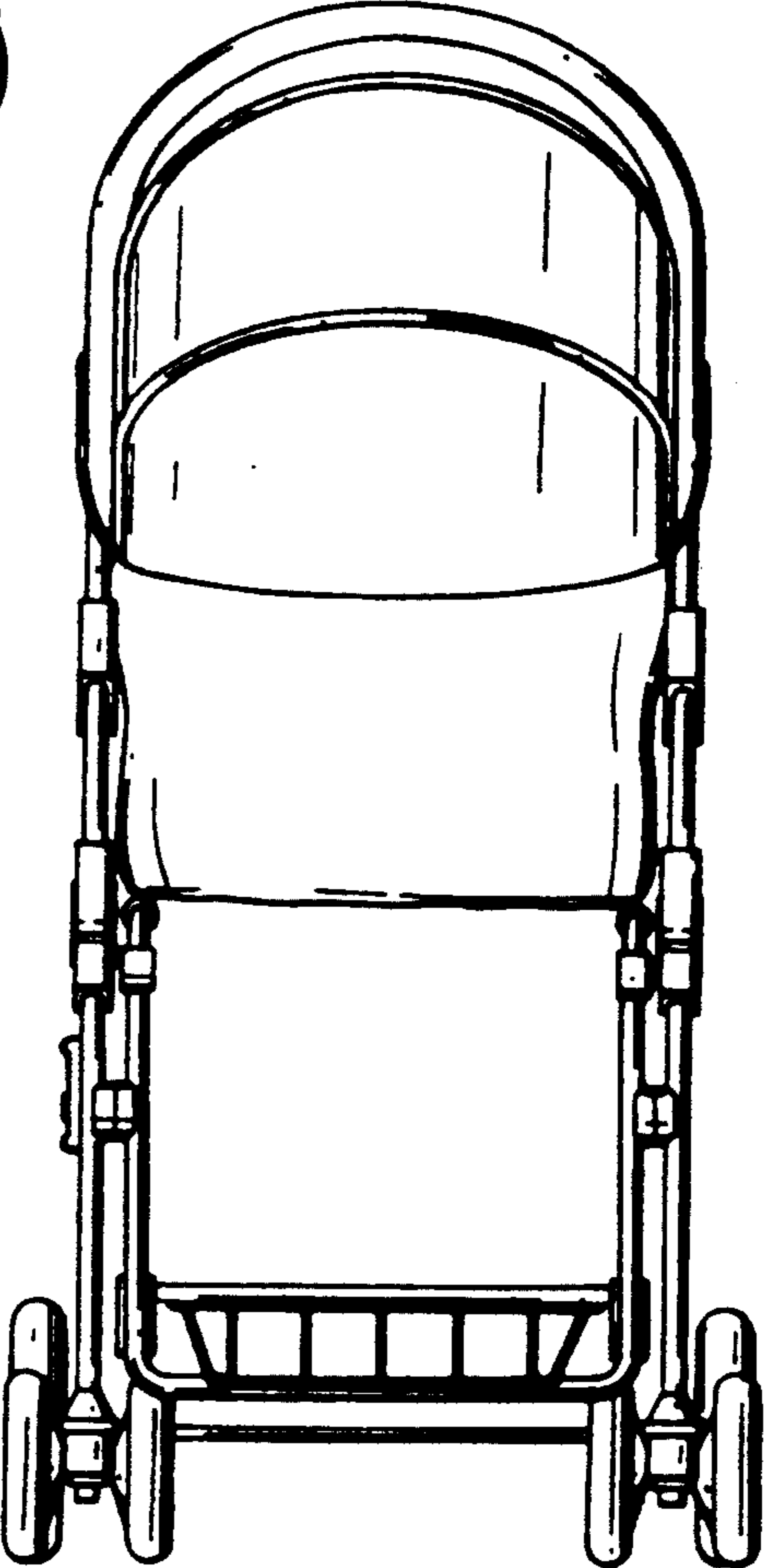

*Fig. 11.*

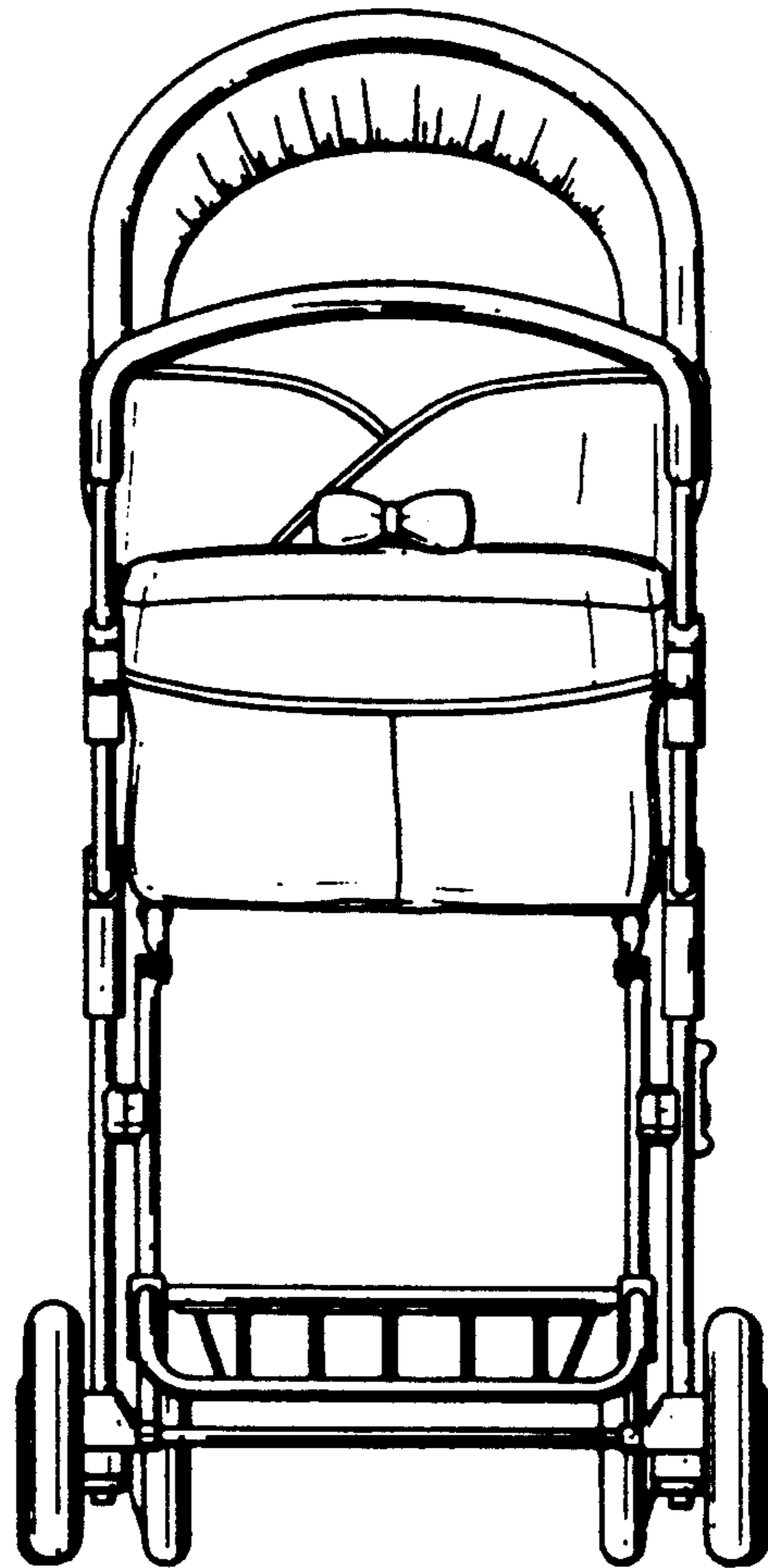

*Fig.12.*

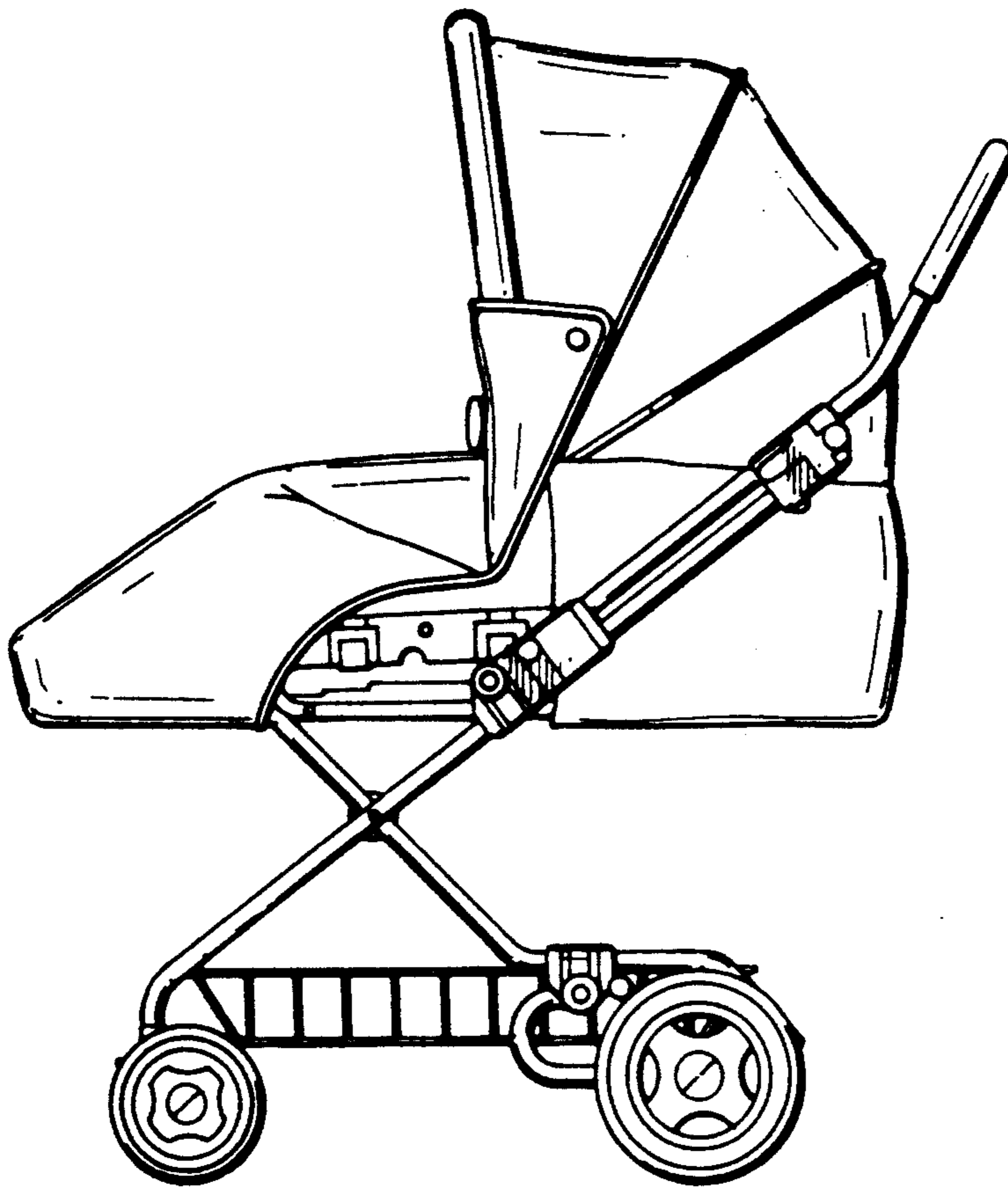

*Fig.13.*

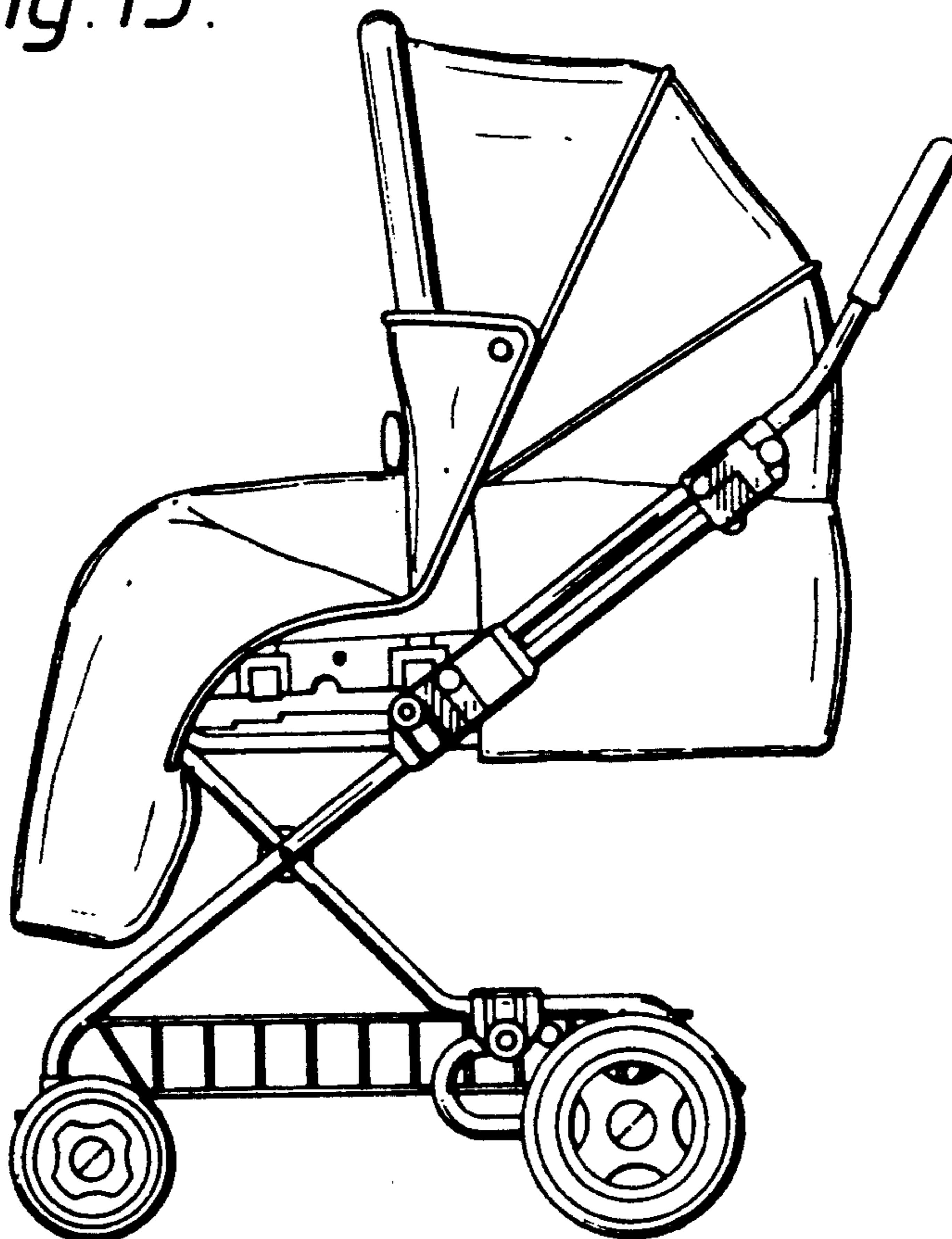

*Fig.14.*