



US00D344625S

United States Patent [19]

[11] Patent Number: **Des. 344,625**

Berry

[45] Date of Patent: **** Mar. 1, 1994**

[54] **PORTABLE TRAY ATTACHMENT FOR VEHICLE**

Attorney, Agent, or Firm—Richard C. Litman

[76] Inventor: **Linda G. Berry**, Rte. 6, Box 168-
Buffalo Creek Rd., South Point,
Ohio 45680

[57] **CLAIM**

The ornamental design for portable tray attachment for vehicle, as shown and described.

[**] Term: **14 Years**

DESCRIPTION

[21] Appl. No.: **686,915**

[22] Filed: **Apr. 9, 1991**

[52] U.S. Cl. **D12/416; D7/706**

[58] Field of Search **D3/40; D7/620, 616,
D7/619; 108/44; 224/273, 275, 42.42; 211/104;
297/163, 191; D12/155**

FIG. 1 is a front and side environmental perspective view of portable tray attachment for vehicle showing my new design with the trays in an open position, the portion of the figure shown in broken lines representing a vehicle seat and forming no part of the claimed design; FIG. 2 is a front and side perspective view thereof, showing the trays in a closed position; FIG. 3 is a front elevational view thereof, showing the trays in a closed position; FIG. 4 is a top plan view thereof, showing the trays in an open position; FIG. 5 is a bottom plan view thereof, showing the trays in an open position; FIG. 6 is a side elevational view thereof showing the trays in an open position, the opposite side elevational view being a mirror image; and, FIG. 7 is a side elevational view thereof showing the trays in a closed position, the opposite side being a mirror image. The securing straps shown in FIGS. 2 through 6 are shown broken, and have been eliminated in FIG. 7 for greater clarity. The rear view of the design is plain and unornamented.

[56] **References Cited**

U.S. PATENT DOCUMENTS

- D. 165,667 1/1952 Sheets D12/155 X
- D. 271,917 12/1983 Magis D3/40
- D. 298,884 12/1988 Rychlock D3/40
- 2,767,895 10/1956 Smith D3/40 X
- 5,046,433 9/1991 Kramer et al. 108/44
- 5,106,003 4/1992 Ma 224/42.42

FOREIGN PATENT DOCUMENTS

- 2029346 3/1980 United Kingdom 224/275

Primary Examiner—Louis S. Zarfes

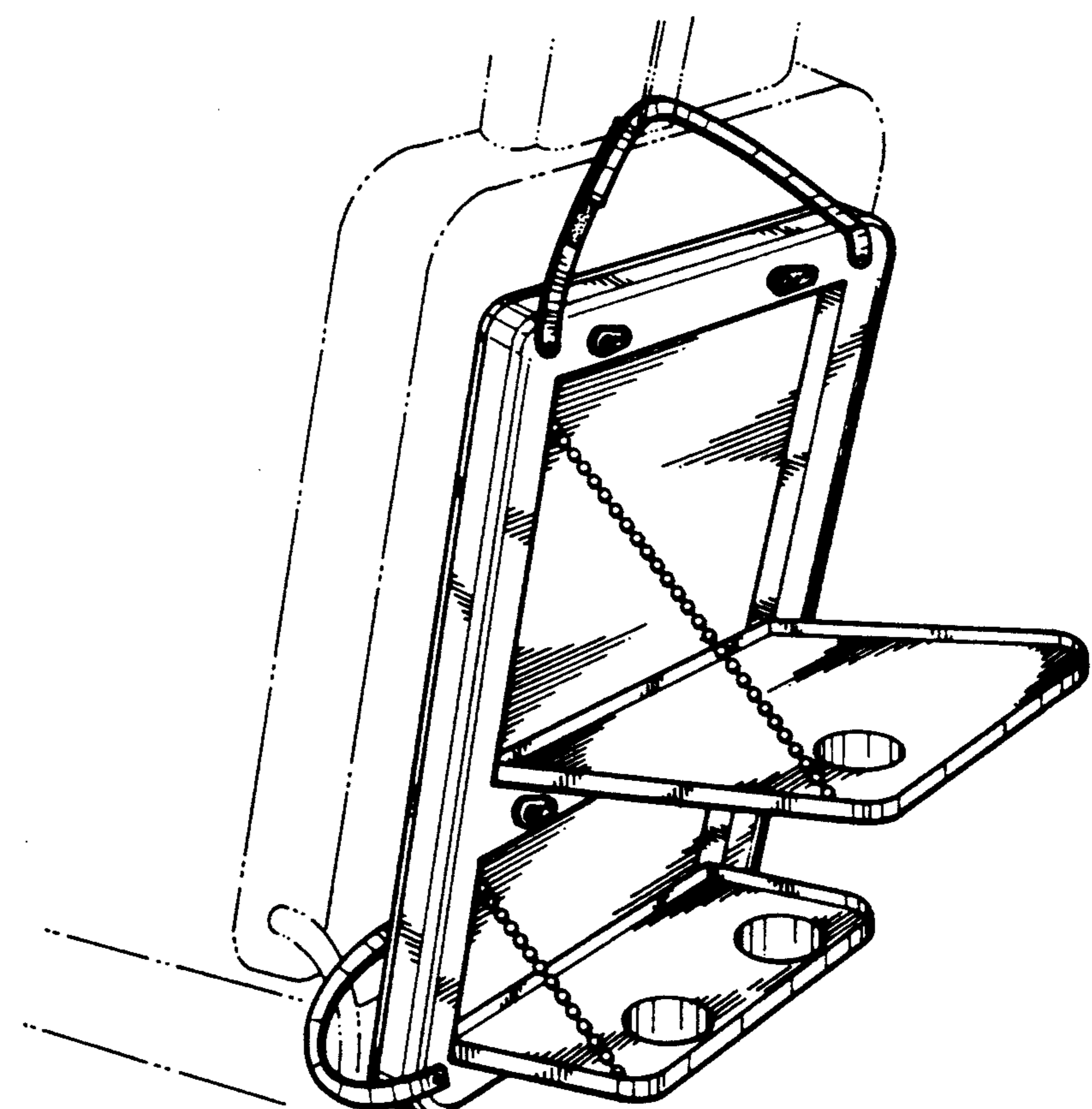

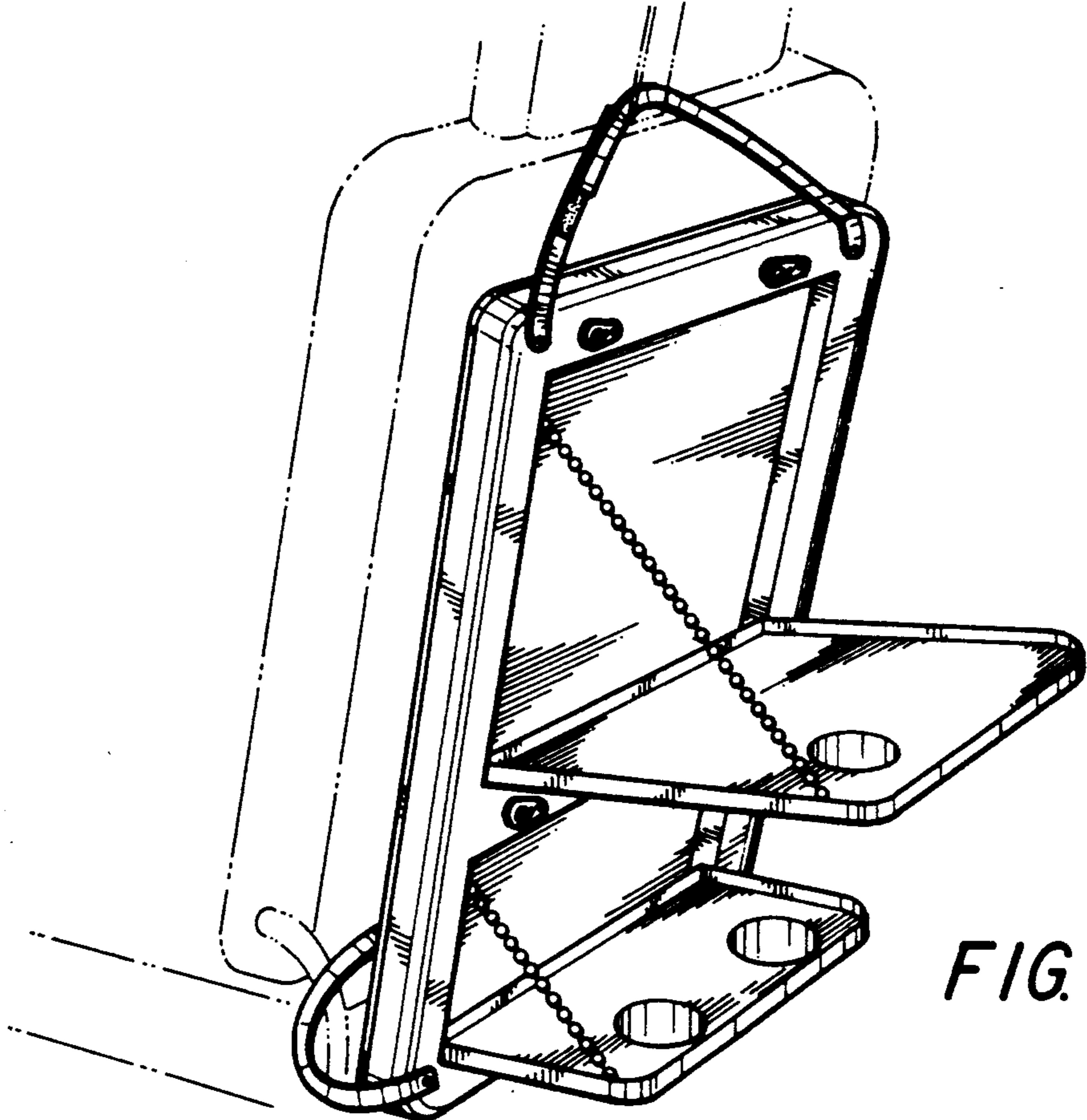

FIG. 1

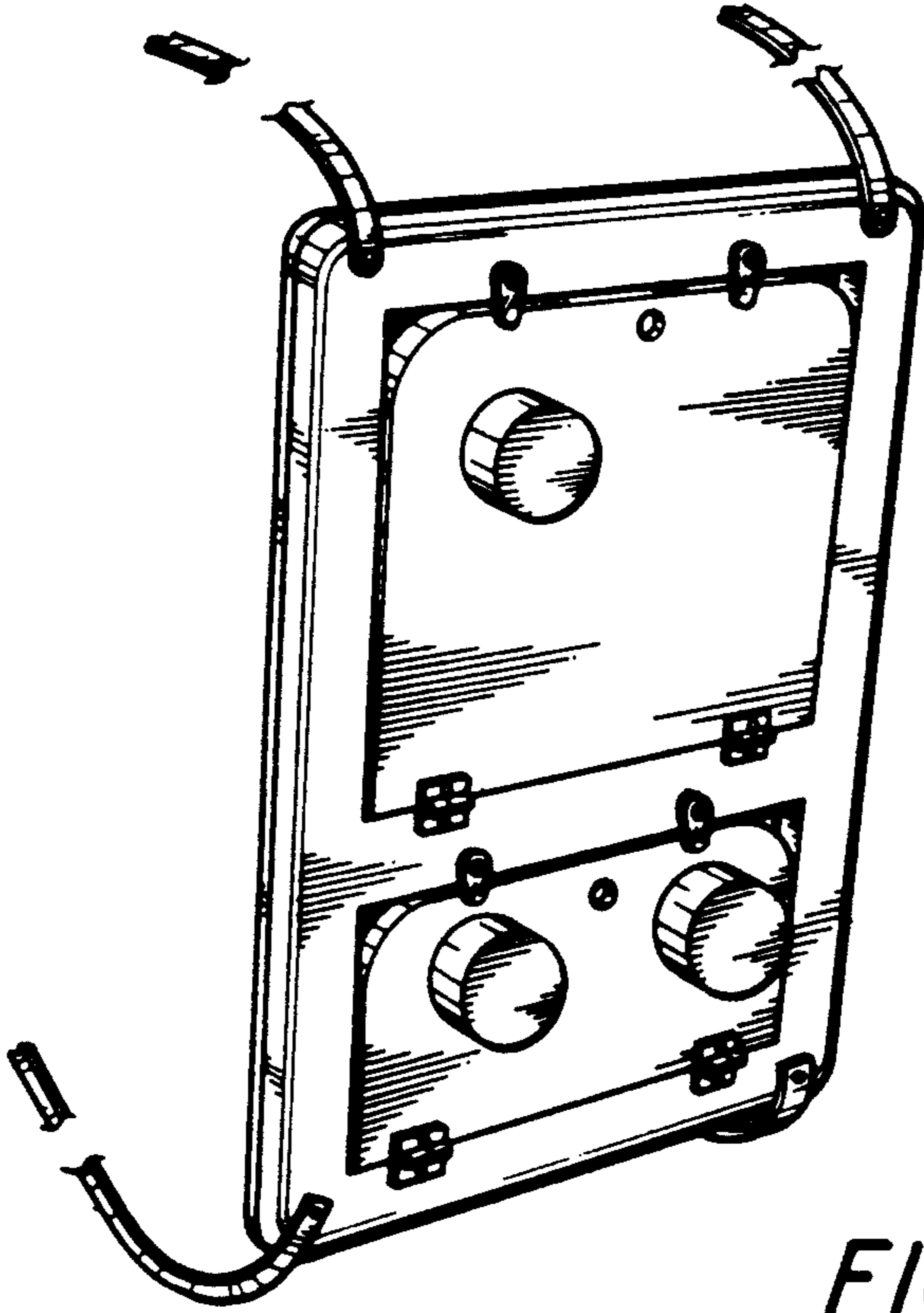

FIG. 2

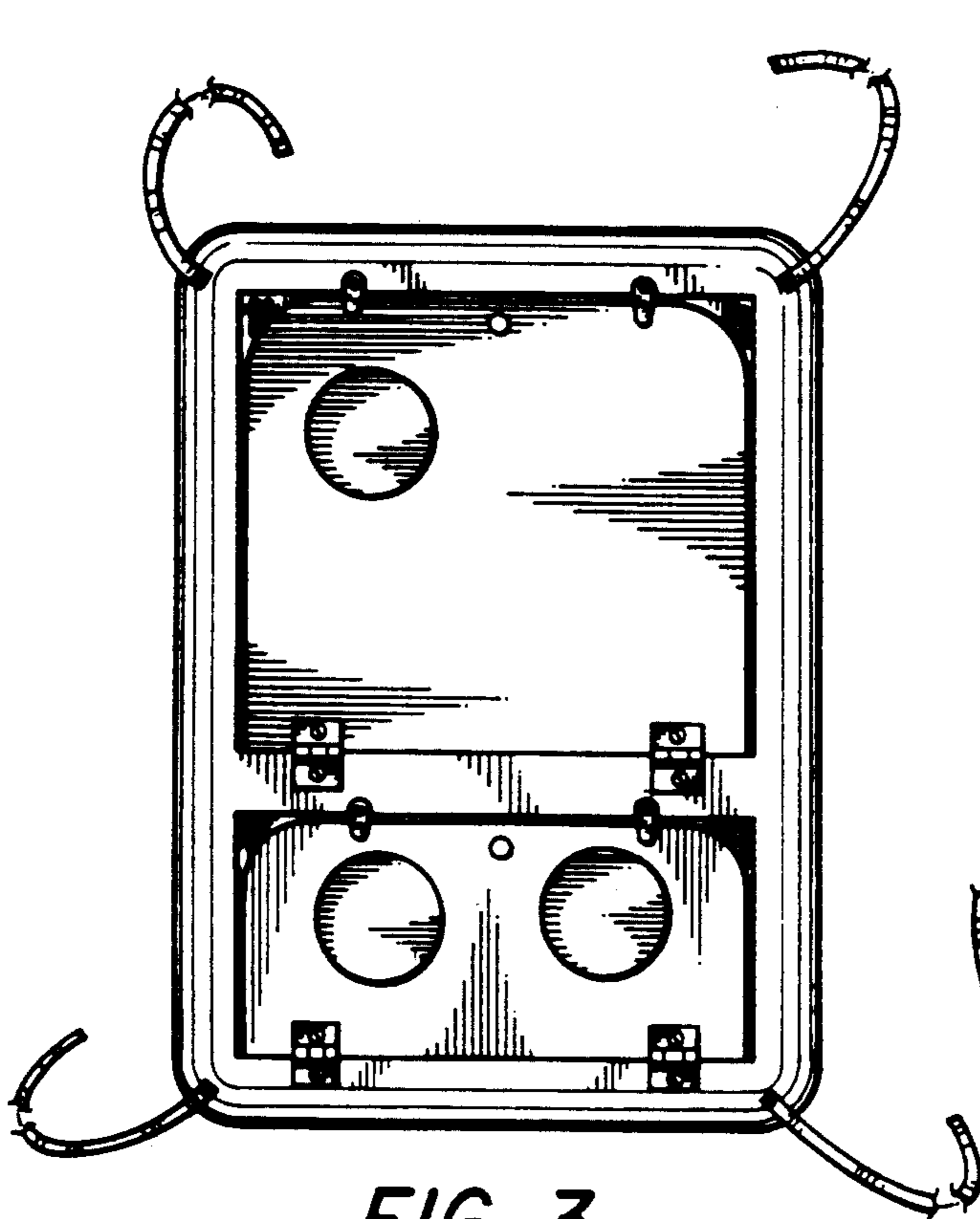

FIG. 3

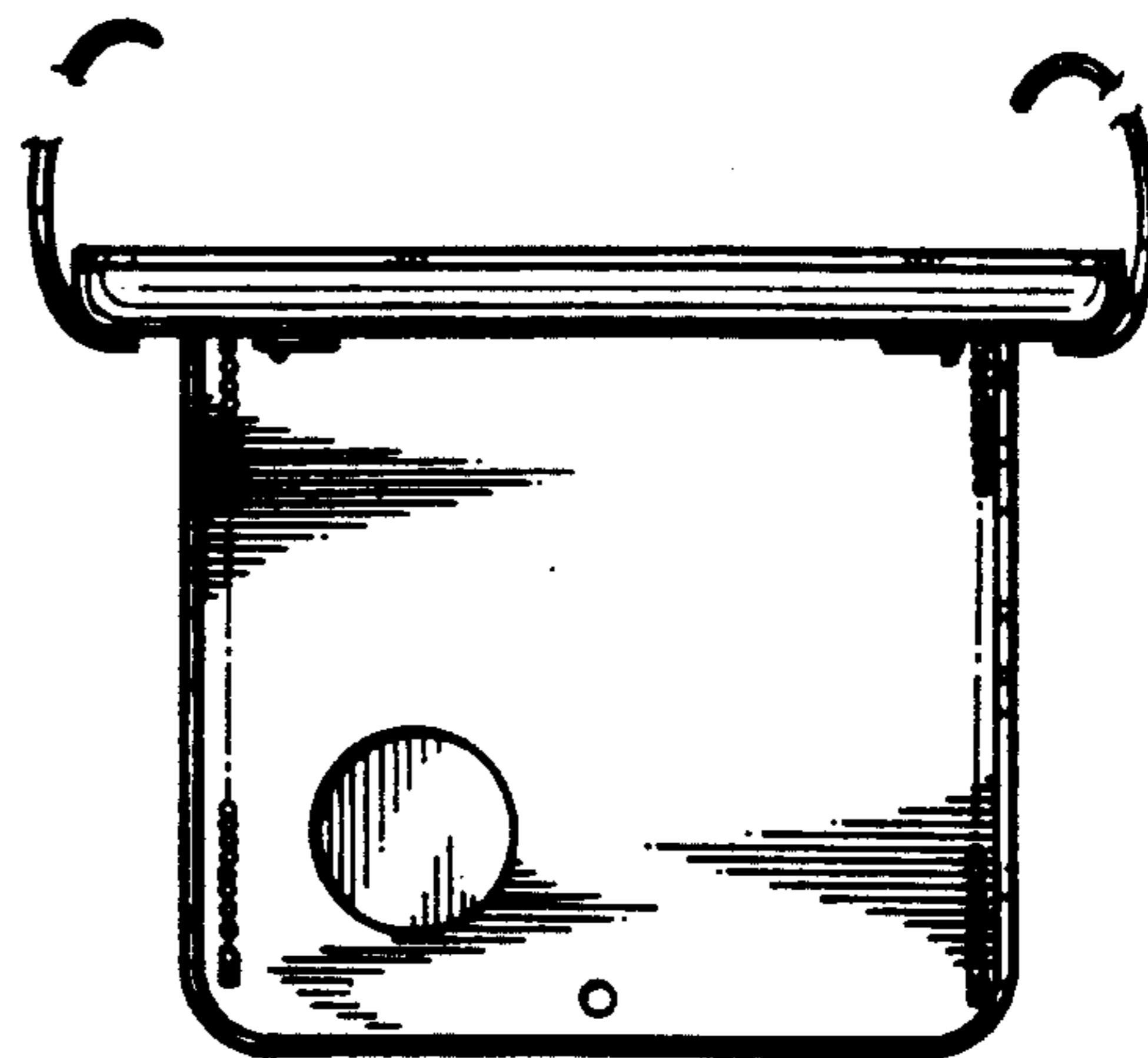

FIG. 4

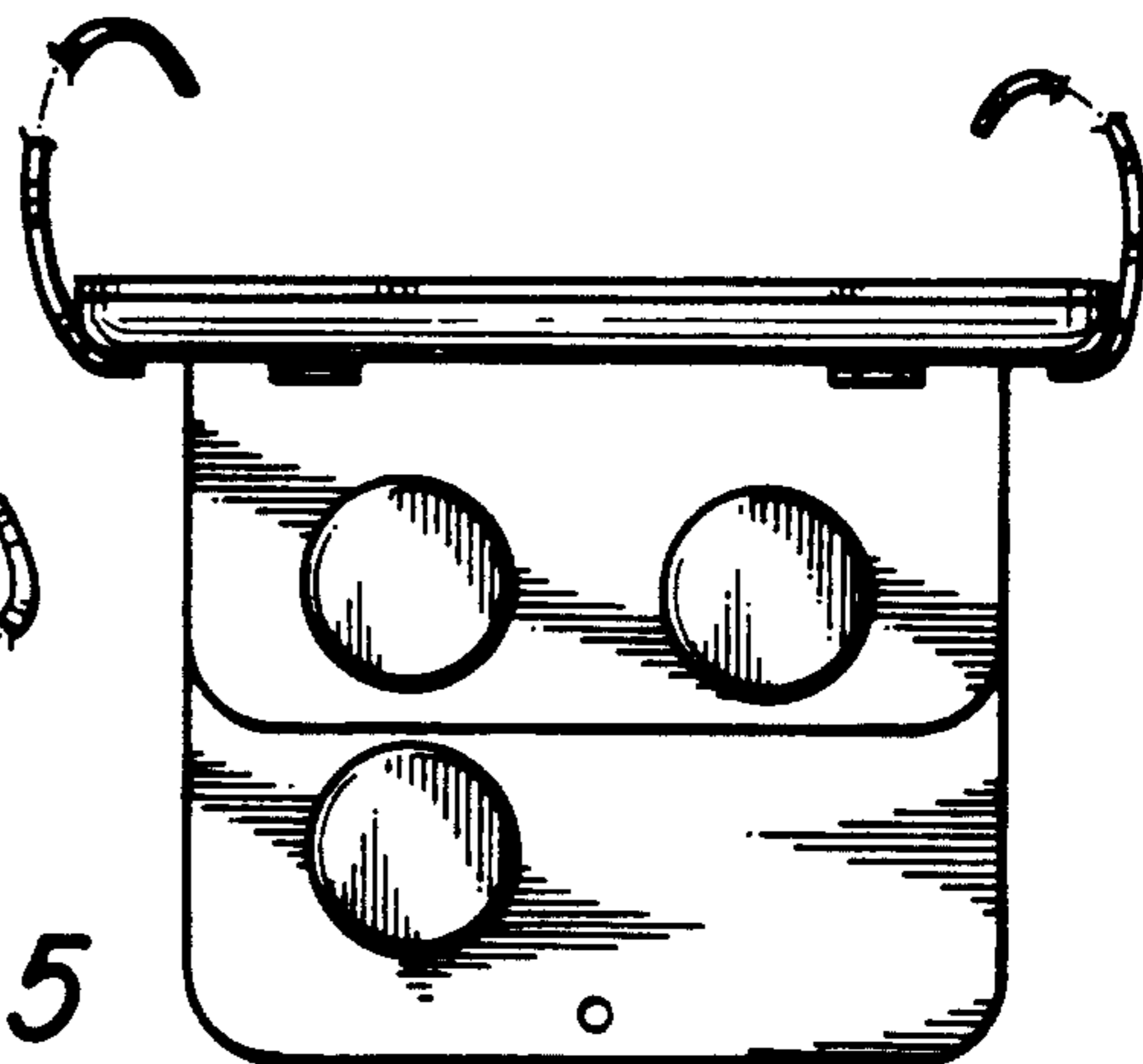

FIG. 5

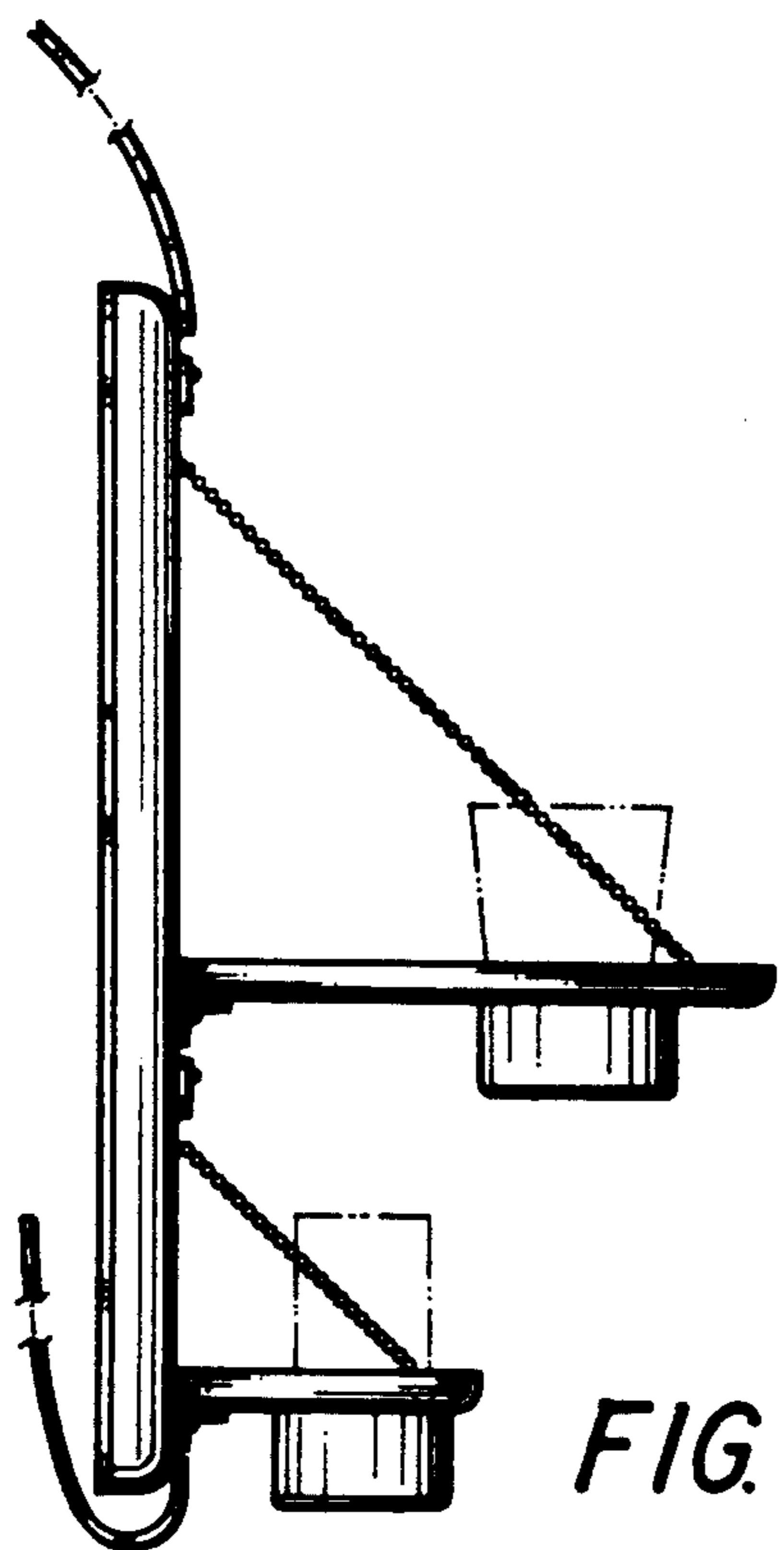

FIG. 6



FIG. 7