



US00D344592S

# United States Patent [19]

Zaccai et al.

[11] Patent Number: **Des. 344,592**

[45] Date of Patent: **\*\* Feb. 22, 1994**

[54] RAIL

2,914,284 11/1959 Tisdall ..... 125/38  
3,544,072 12/1970 Thom ..... 256/59

[75] Inventors: **Gianfranco Zaccai**, Boston; **Arthur S. Rousmaniere**, Andover; **Timothy C. Dearborn**, Wellesley; **Lynn Noble**, Lexington; **Thomas J. Misage**, Somerville, all of Mass.

*Primary Examiner*—A. Hugo Word  
*Assistant Examiner*—Doris Clark  
*Attorney, Agent, or Firm*—William Brinks Hofer Gilson & Lione

[73] Assignee: **Herman Miller, Inc.**, Zeeland, Mich.

[57] **CLAIM**

[\*\*] Term: **14 Years**

The ornamental design for a rail, as shown and described.

[21] Appl. No.: **847,255**

### DESCRIPTION

[22] Filed: **Mar. 6, 1992**

[52] U.S. Cl. .... **D25/38**

[58] Field of Search ..... 256/59, 66, 70, 72,  
256/61-65; D25/38, 43, 44

FIG. 1 is a perspective view of a rail showing our new design, the broken lines showing a wall are for illustrative purposes only and form no part of the claimed design;

[56] **References Cited**

### U.S. PATENT DOCUMENTS

D. 335,353 5/1993 Baker ..... D25/38

FIG. 2 is a side view of the rail shown in FIG. 1;  
FIG. 3 is a top view of the rail shown in FIG. 1;  
FIG. 4 is a front view of the rail shown in FIG. 1; and,  
FIG. 5 is a bottom view of the rail shown in FIG. 1.

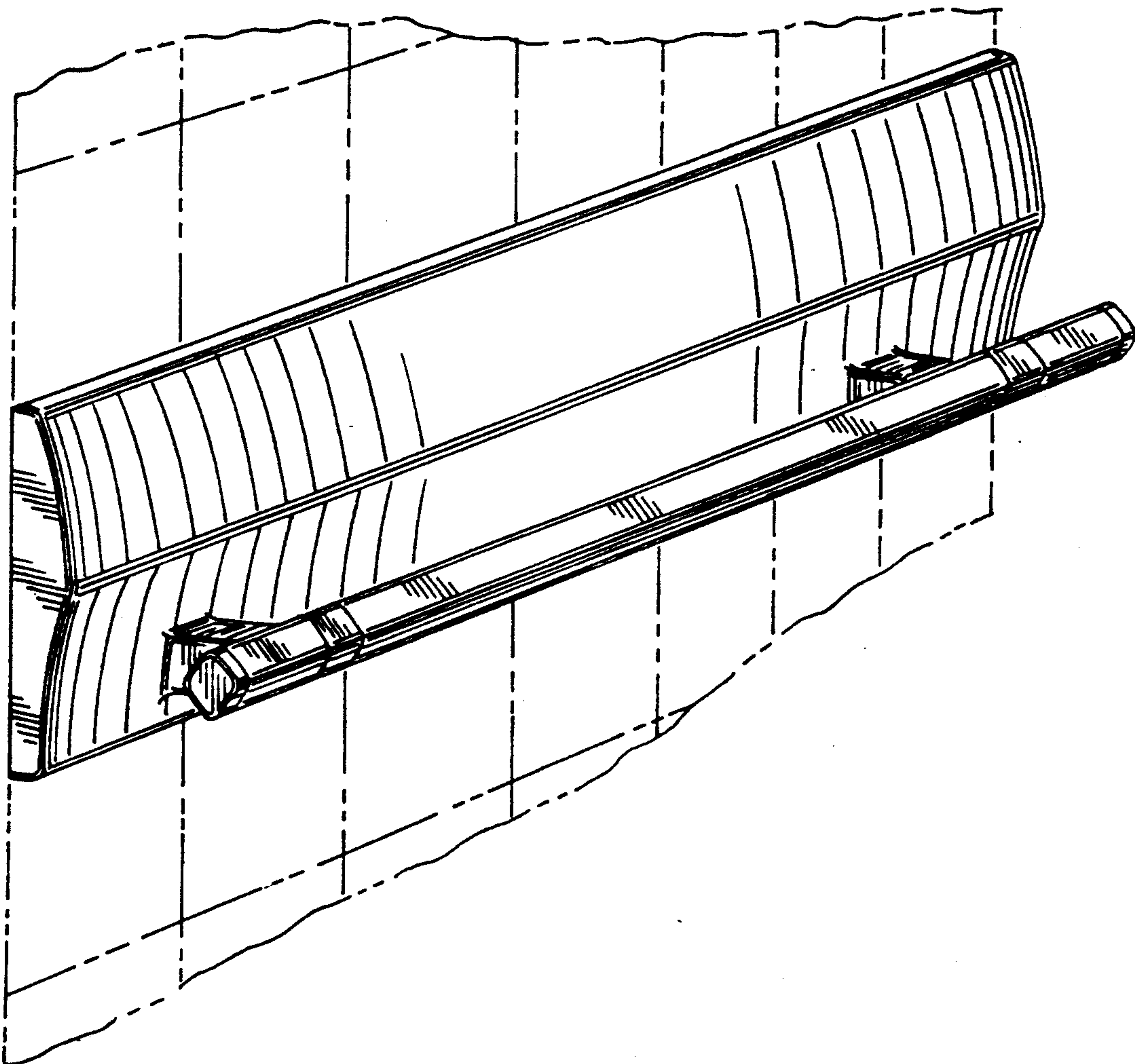

FIG. 1

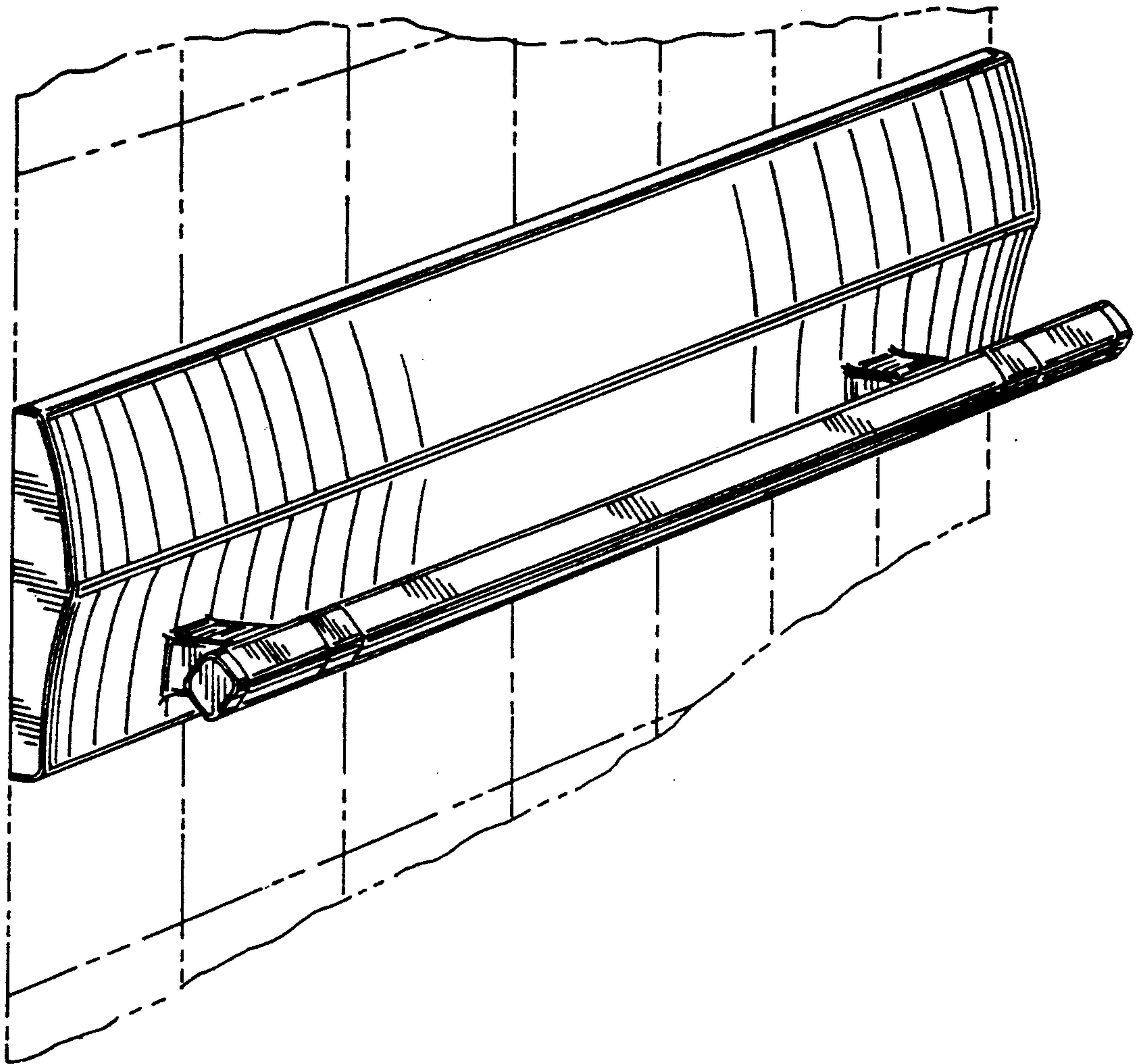

FIG. 2

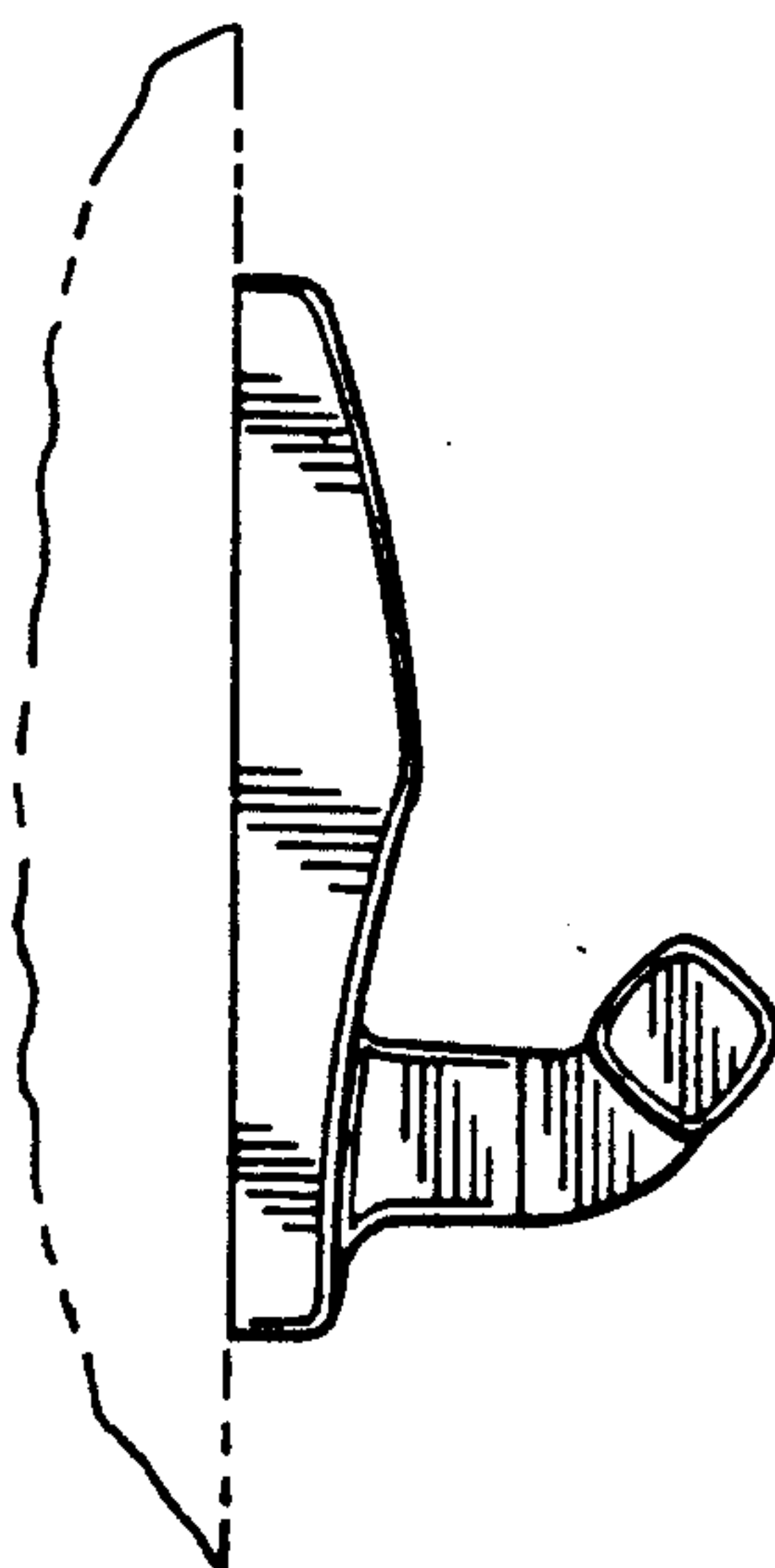

FIG. 3

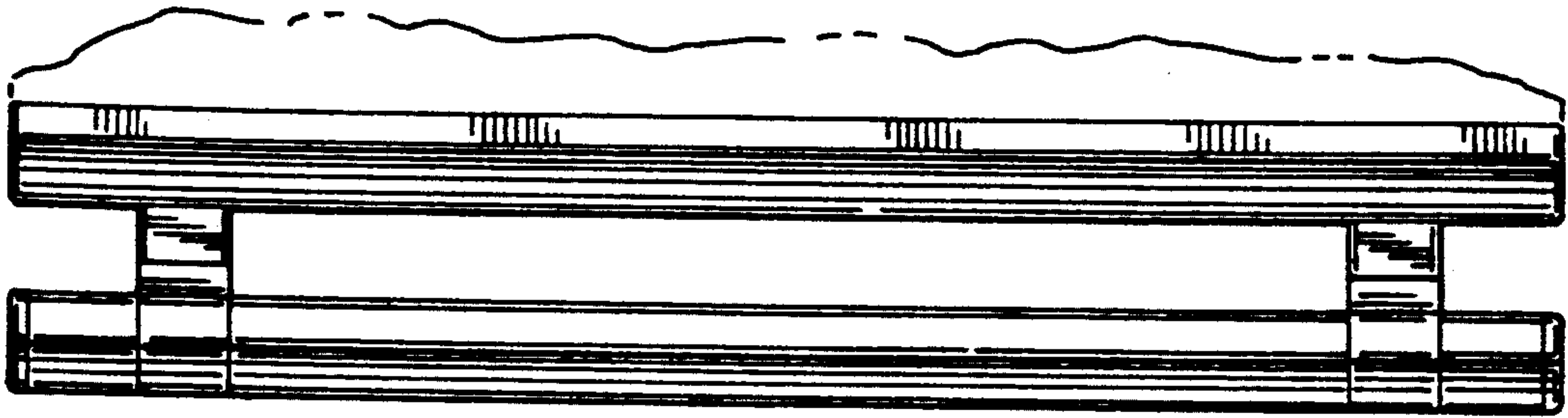

FIG. 4

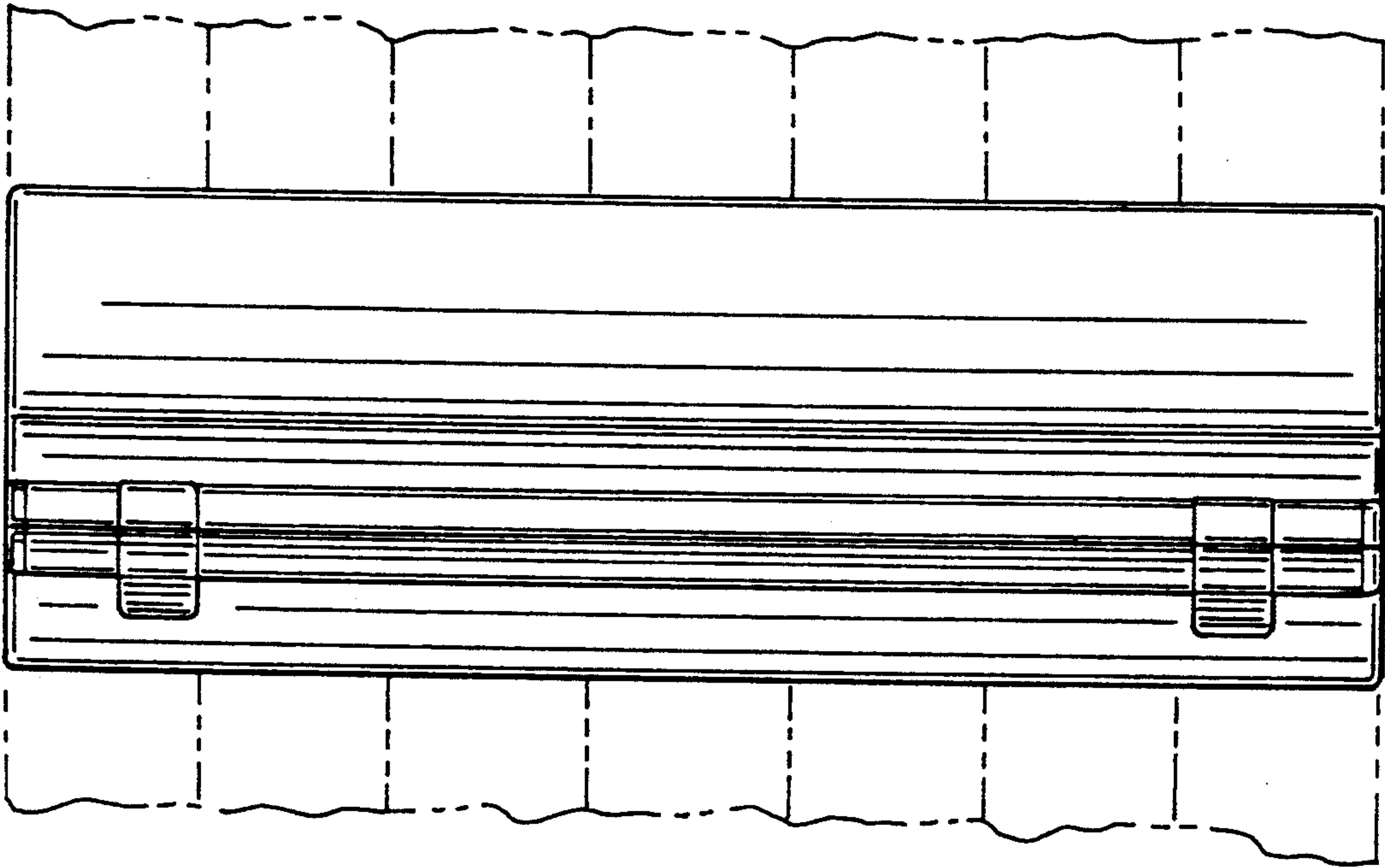

FIG. 5

