



US00D344504S

United States Patent [19]

Barr et al.

[11] Patent Number: **Des. 344,504**

[45] Date of Patent: **** Feb. 22, 1994**

[54] CARTRIDGE FOR VIDEO GAME MACHINE

[75] Inventors: **Lance Barr, Redmond, Wash.;**
Mitsuru Hitomi, Kyoto, Japan

[73] Assignee: **Nintendo Co., Ltd., Japan**

[**] Term: **14 Years**

[21] Appl. No.: **6,544**

[22] Filed: **May 10, 1993**

Related U.S. Application Data

[62] Division of Ser. No. 757,431, Sep. 10, 1991.

[30] Foreign Application Priority Data

Mar. 26, 1991 [JP] Japan 3-8433

[52] U.S. Cl. **D14/121**

[58] Field of Search 242/55.19 A, 197-200;
273/DIG. 28, 85.6; D14/114, 120-122, 299

[56] References Cited

U.S. PATENT DOCUMENTS

- D. 252,753 8/1979 Thompson et al. D14/114
- D. 260,515 9/1981 Welch et al. D14/121 X
- D. 260,881 9/1981 McKinsey et al. D14/114
- D. 277,189 1/1985 Shibata D14/114
- D. 285,307 8/1986 Clarke D14/121 X

Primary Examiner—Theodore M. Shooman
Attorney, Agent, or Firm—Nixon & Vanderhye

[57] CLAIM

The ornamental design for a cartridge for video game machine, as shown and described.

DESCRIPTION

FIG. 1 is a front, top and right side perspective view of a cartridge for video game machine showing my new design;

FIG. 2 is a rear, bottom and left side perspective view thereof;

FIG. 3 is a front, top and right side perspective view of a second embodiment of the cartridge disclosed in FIG. 1; and,

FIG. 4 is a rear, bottom and left side perspective view thereof.

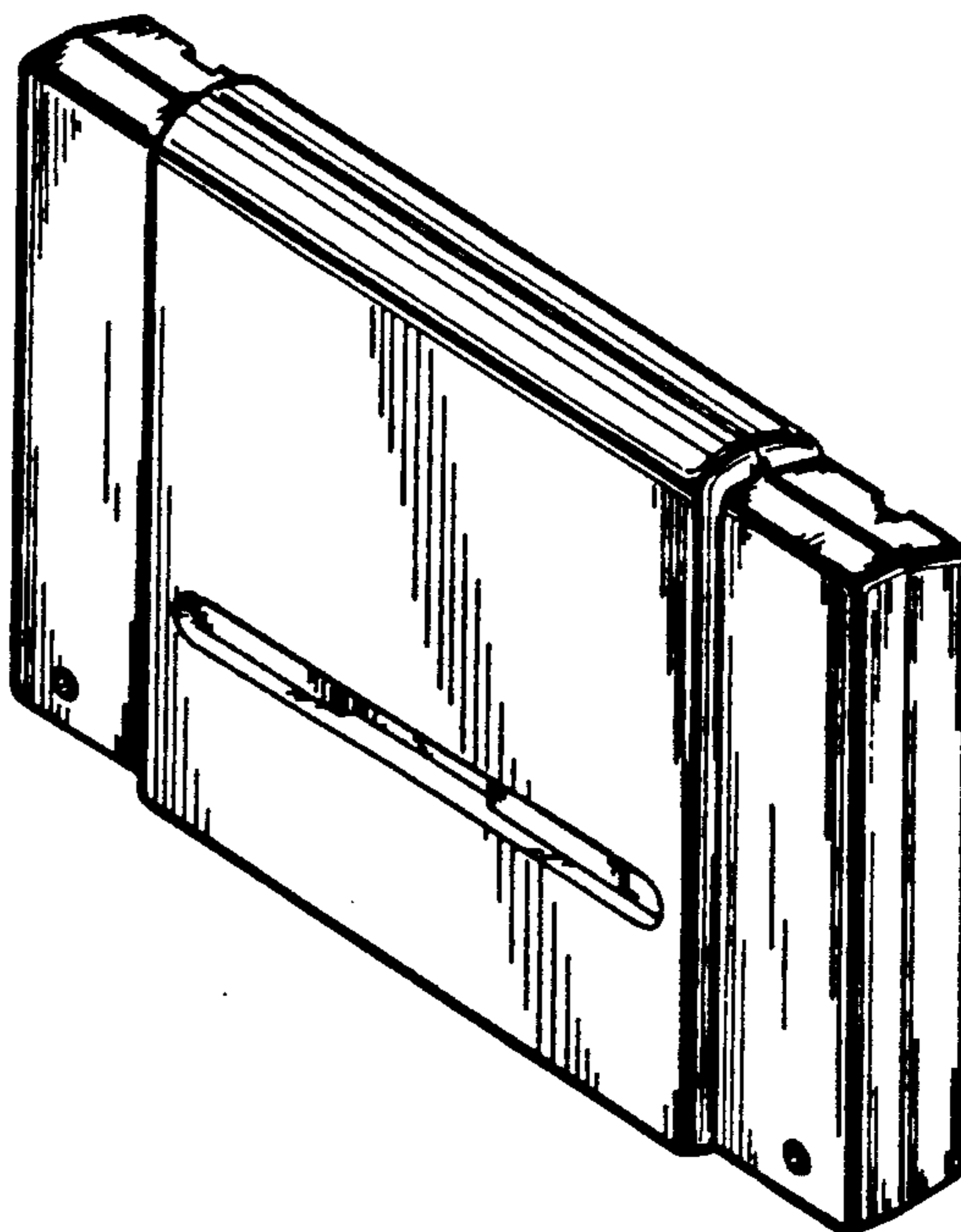
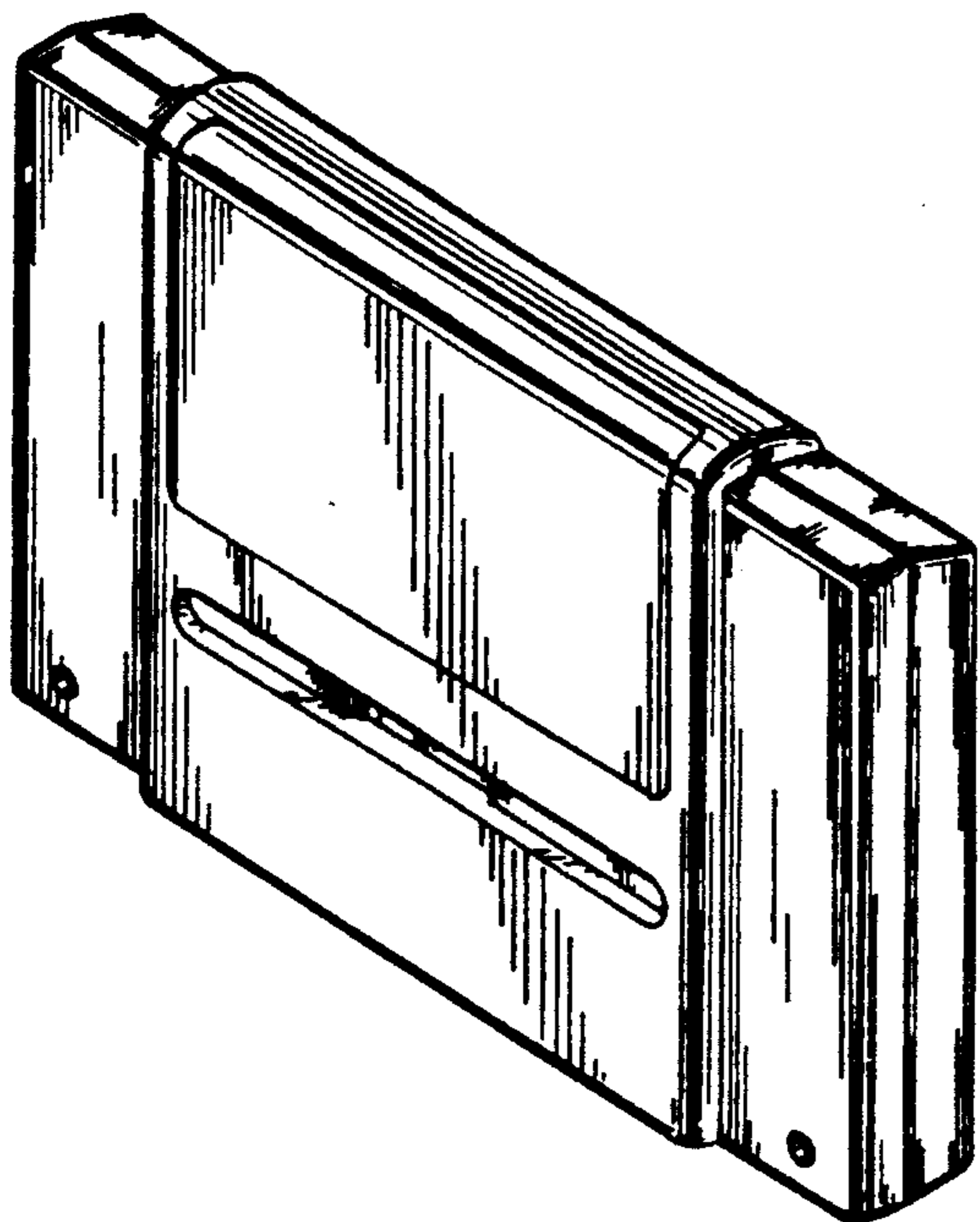

FIG. 1

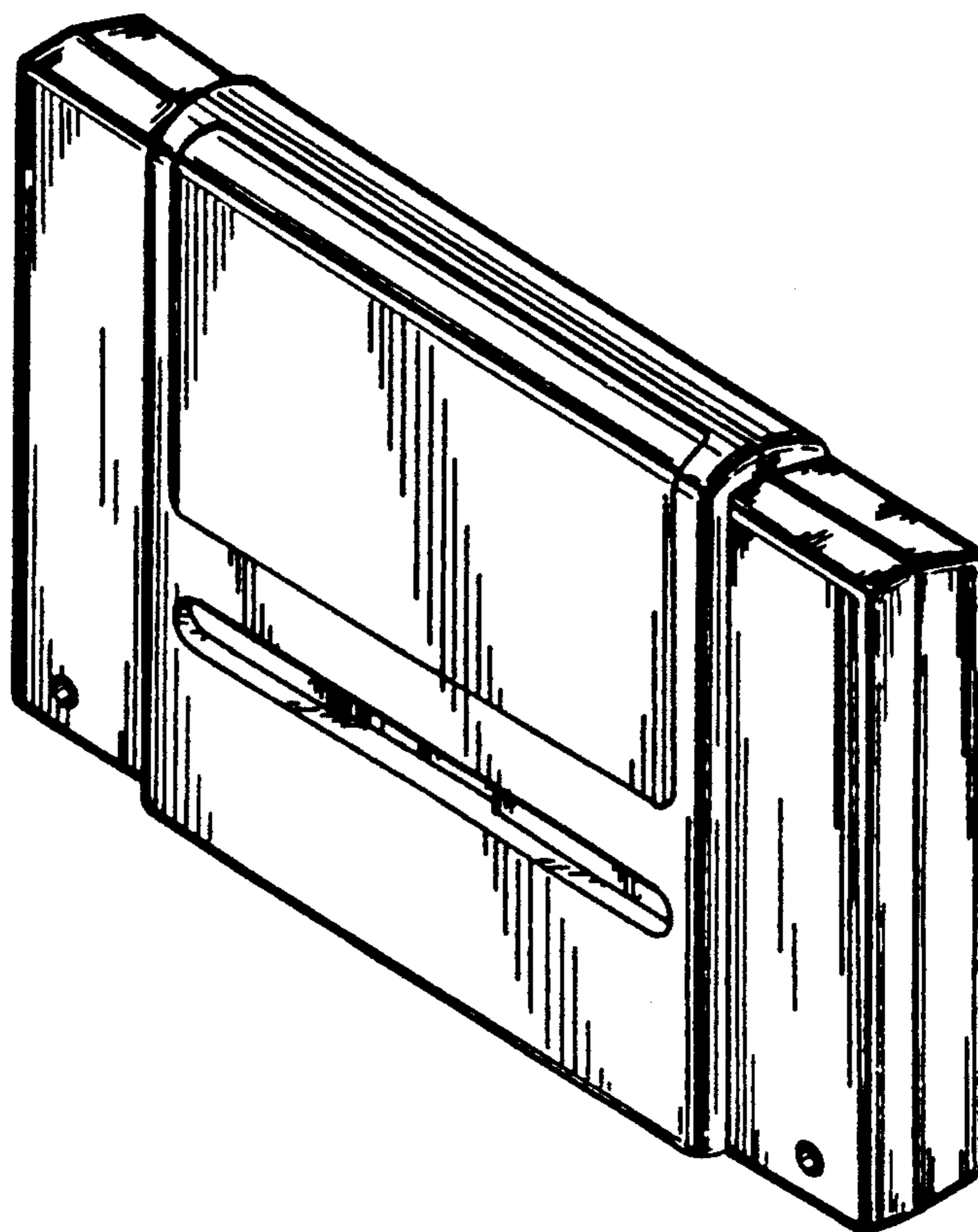

FIG. 2

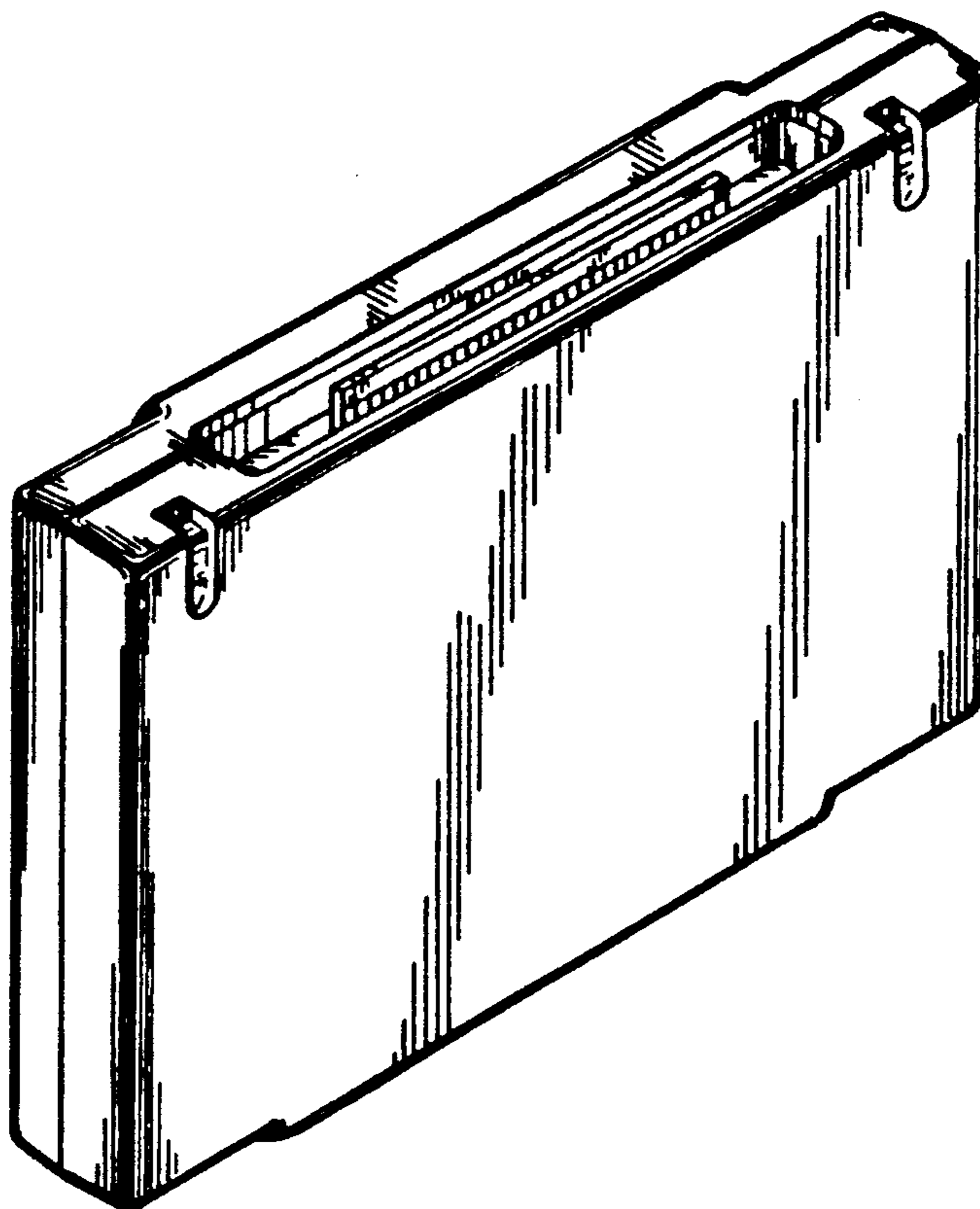

FIG. 3

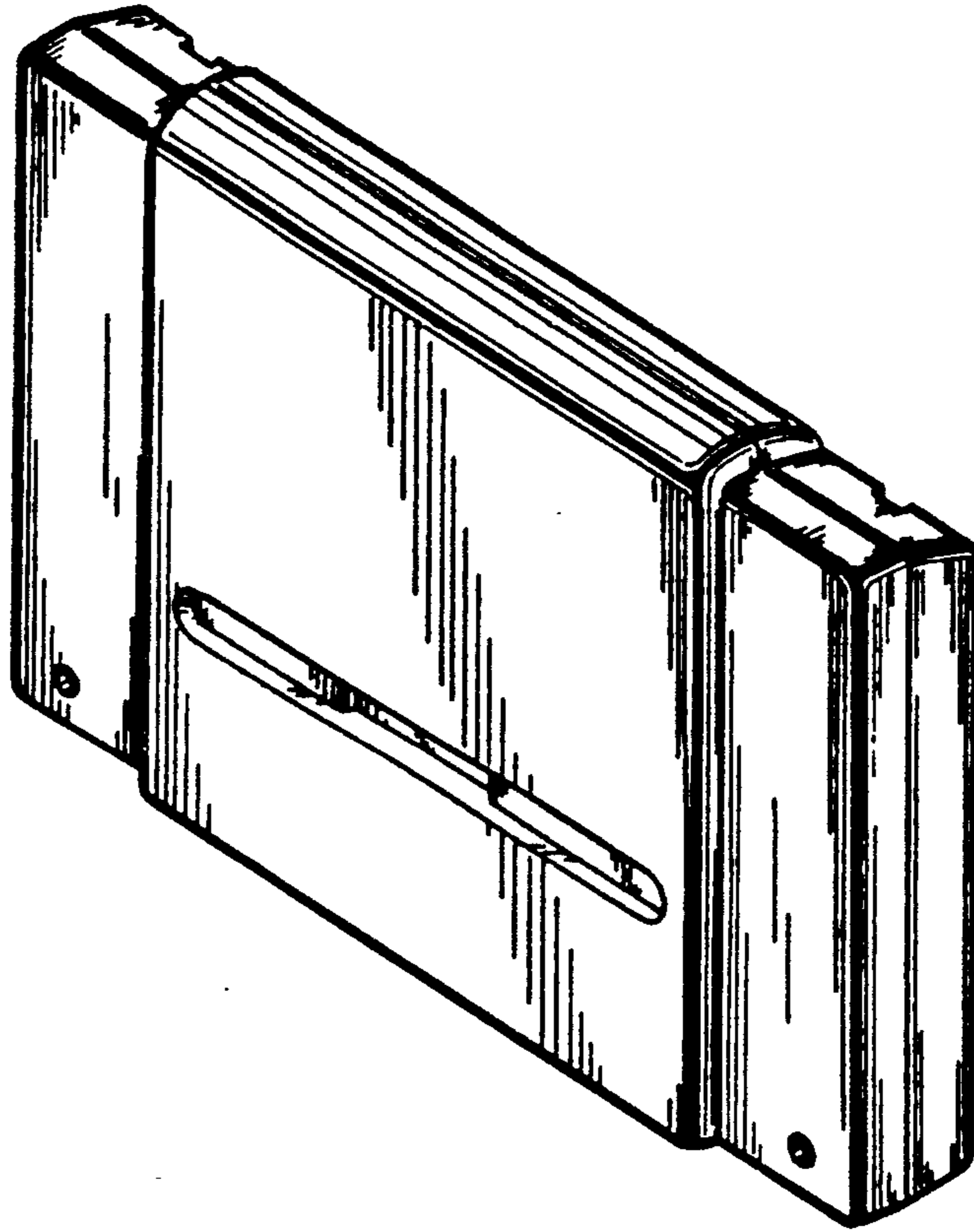

FIG. 4

