



US00D344481S

United States Patent [19]

[11] Patent Number: **Des. 344,481**

Ryan

[45] Date of Patent: **** Feb. 22, 1994**

[54] **TRUNK LINER**

[75] Inventor: **Patrick T. Ryan, Windsor Jct., Canada**

[73] Assignee: **NeoCon International Inc., Halifax, Canada**

[**] Term: **14 Years**

[21] Appl. No.: **1,955**

[22] Filed: **Nov. 27, 1992**

[52] U.S. Cl. **D12/221**

[58] Field of Search **296/24.1, 37.1, 37.16, 296/39.1; D12/155**

[56] **References Cited**

U.S. PATENT DOCUMENTS

D. 289,513	4/1987	Hankinson, Jr.	D12/155
D. 293,226	12/1987	Whitson	D12/155
D. 302,143	7/1989	Whitson	D12/155
D. 333,645	3/1993	Tyler	D12/155
3,473,680	10/1969	Downer	296/37.1
4,305,695	12/1981	Zachrich	296/37.1
4,944,544	7/1990	Dick	296/37.1
5,083,827	1/1992	Hollenbaugh, Sr.	296/37.16
5,167,433	12/1992	Ryan	296/24.1
5,205,602	4/1993	Hoare et al.	296/39.1

OTHER PUBLICATIONS

J. C. Whitney Catalog No. 540 p. 8, Custom-Fit Cargo Area Tray, Top Right Side of Page.

J. C. Whitney Catalog N. 540 p. 98, Portable Cargo Tray, Bottom Left Center of Page.

Primary Examiner—James M. Gandy

Attorney, Agent, or Firm—Armstrong, R. Craig

[57] **CLAIM**

The ornamental design for a trunk liner, as shown and described.

DESCRIPTION

FIG. 1 is a perspective view of the top, rear and right side of a trunk liner showing my new design;

FIG. 2 is a top plan view thereof;

FIG. 3 is a rear elevation view thereof;

FIG. 4 is a right side elevation view thereof;

FIG. 5 is a left side elevation view thereof;

FIG. 6 is a front elevation view thereof;

FIG. 7 is top plan view of a second embodiment thereof;

FIG. 8 is a top plan view of a third embodiment thereof; FIG. 9 is a top plan view of a fourth embodiment thereof;

FIG. 10 is a top plan view of a fifth embodiment thereof;

FIG. 11 is a perspective view of the top, rear and right side of a sixth embodiment thereof;

FIG. 12 is top plan view of the sixth embodiment thereof;

FIG. 13 is top plan view of a seventh embodiment thereof;

FIG. 14 is a perspective view of the top, rear and right side of an eighth embodiment which differs from the first embodiment only in the addition of dividers installed at the rear thereof;

FIG. 15 is a perspective view of the top, rear and right side of a ninth embodiment which differs from the sixth embodiment only in the addition of dividers installed at the front thereof;

FIG. 16 is a perspective view of the top, rear and right side of a tenth embodiment which differs from the sixth embodiment only in the addition of dividers installed at the front and rear thereof;

FIG. 17 is a perspective view of the top, rear and right side of an eleventh embodiment thereof;

FIG. 18 is top plan view of the eleventh embodiment thereof;

FIG. 19 is a perspective view of the top, rear and right side of a twelfth embodiment which differs from the eleventh embodiment only in the addition of dividers installed at the rear thereof; and,

FIG. 20 is a perspective view of the top, rear and right side of a thirteenth embodiment which differs from the eleventh embodiment only in the addition of dividers installed along one side thereof.

The front, rear and side walls of the second, third, fourth and fifth embodiments of the claimed design are substantially the same as the first embodiment as shown in FIGS. 3-6 of the drawing and differ only in their length, and the shape of the side walls with respect to the fourth and fifth embodiments, as defined in the top plan views of FIGS. 7-10 respectively. In addition, the

(Description continued on next page.)

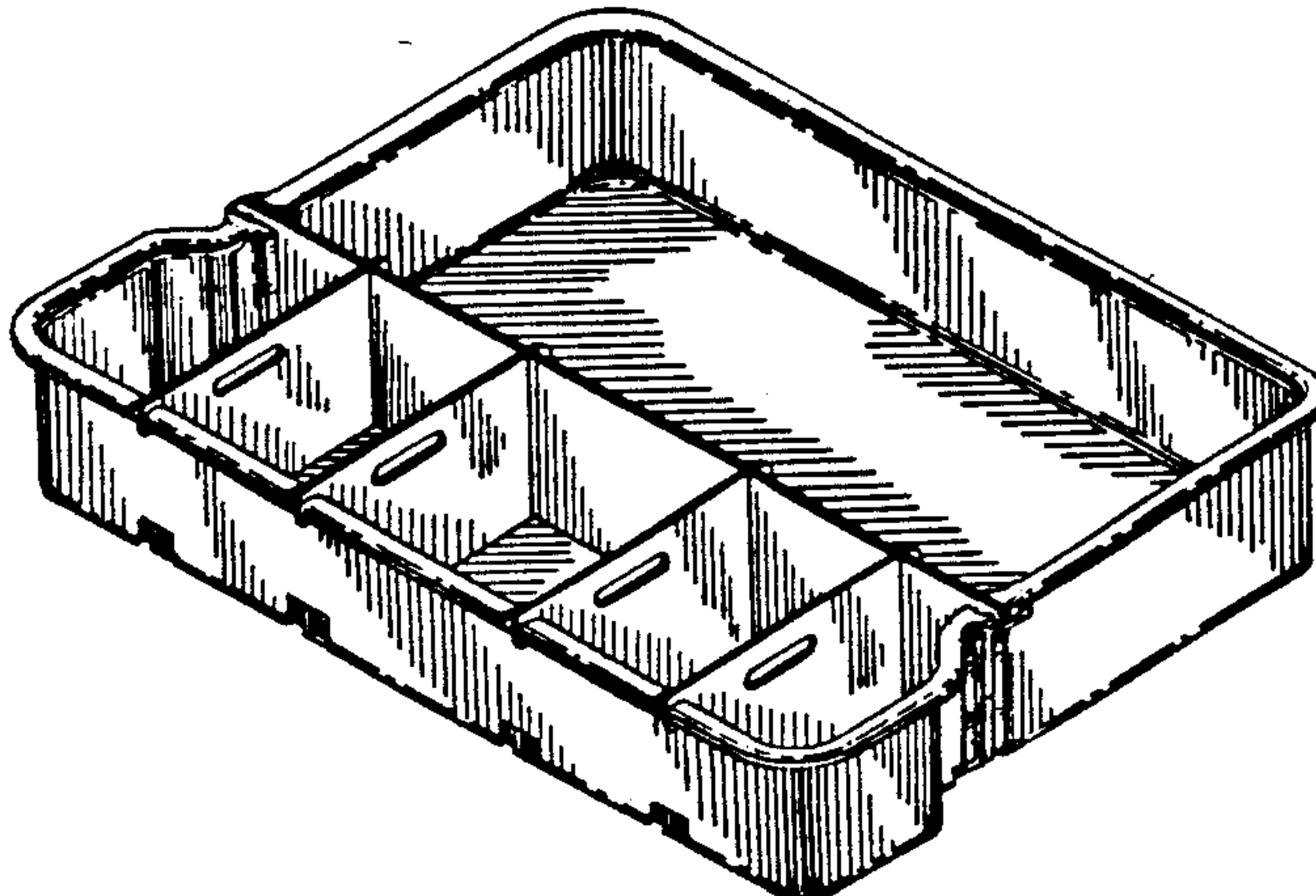

DESCRIPTION

front, rear and side walls of the sixth, seventh, ninth and tenth embodiments are also substantially the same as those of the first embodiment except in their length and specific shape as well as the inclusion of a second vertically elongated groove and pair of ribs in each of the side walls and the inclusion of two notches in the top of the front wall in combination with two short grooves and pairs of ribs at the bottom of the front wall which

correspond to those in the rear wall of the first embodiment shown in FIGS. 1, 2 and 3 of the drawing. Furthermore, the front and left side wall of the eleventh, twelfth and thirteenth embodiments differ from the first embodiment in their length and the inclusion of a vertically elongated groove and pair of ribs in the front wall and the addition of three notches in the top of the left side wall in combination with three short grooves and pairs of ribs at the bottom of the

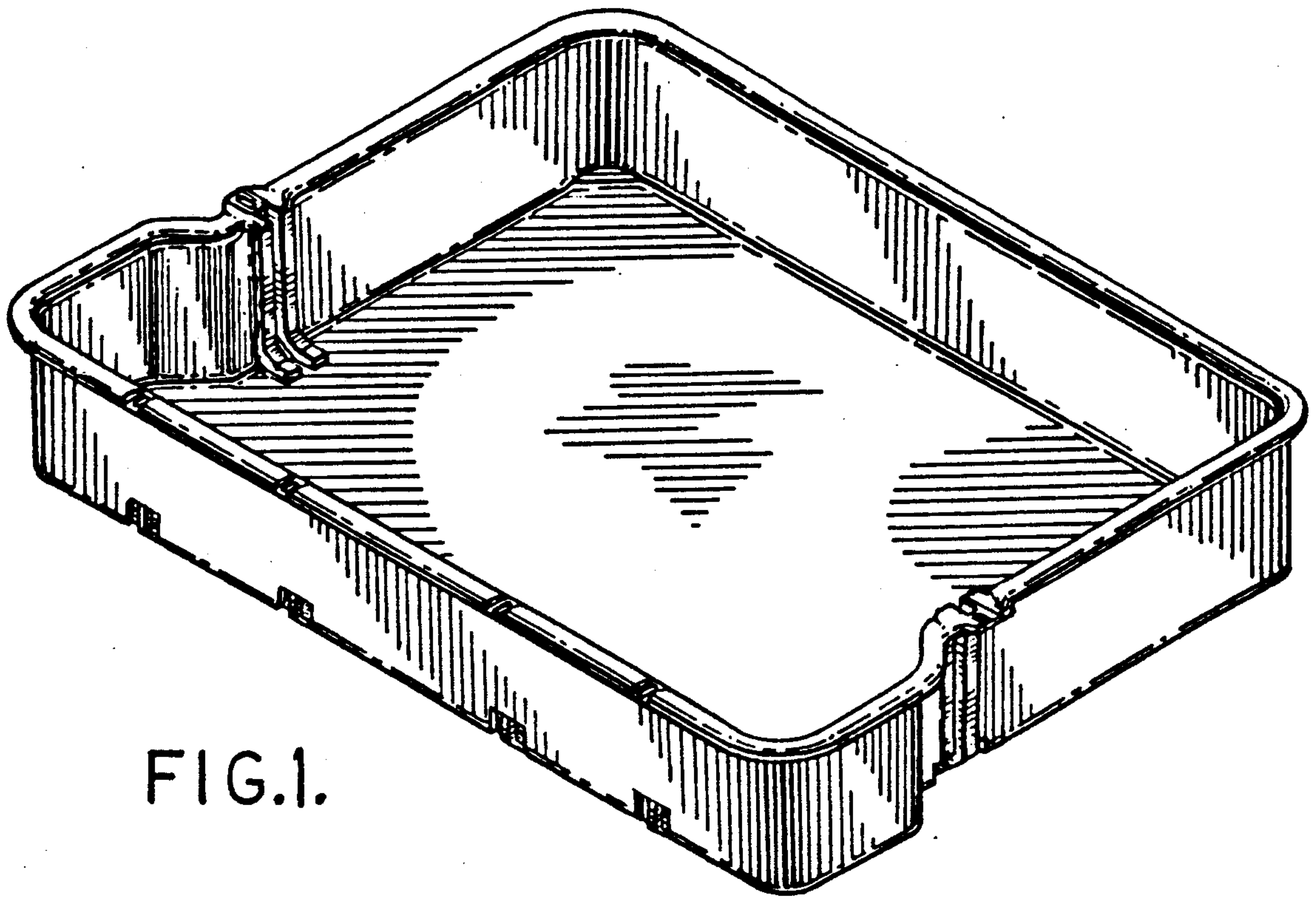

FIG.1.

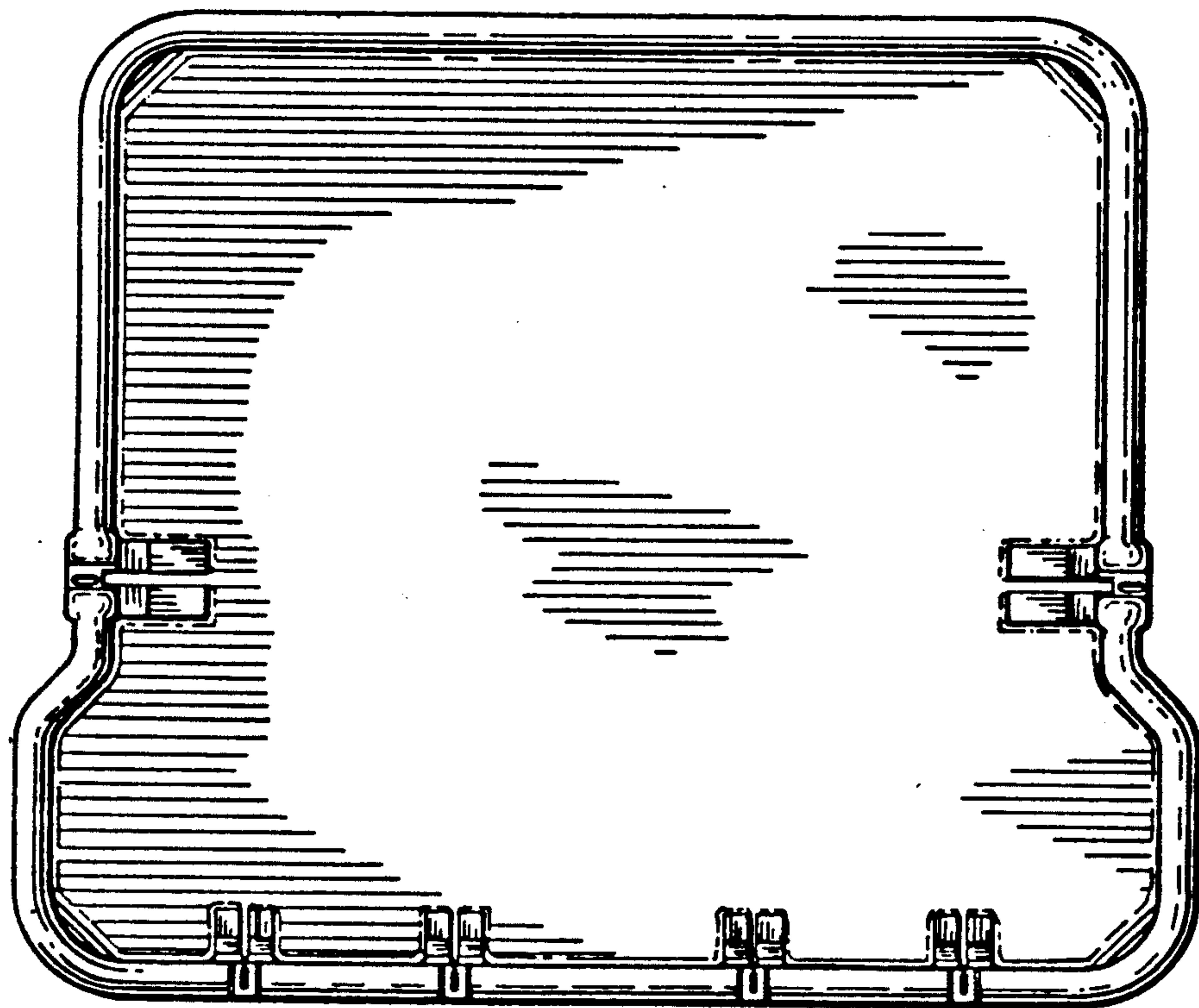

FIG.2.

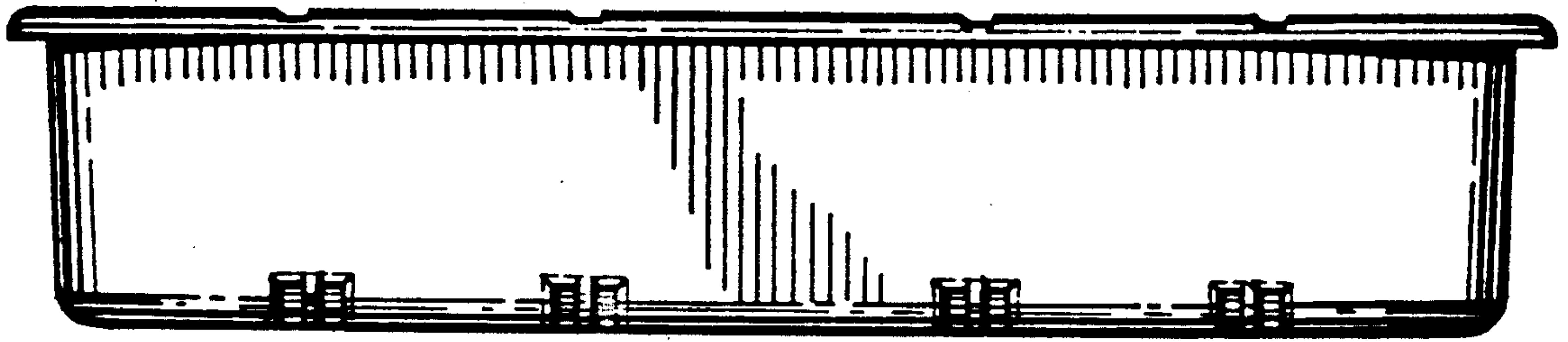

FIG. 3.

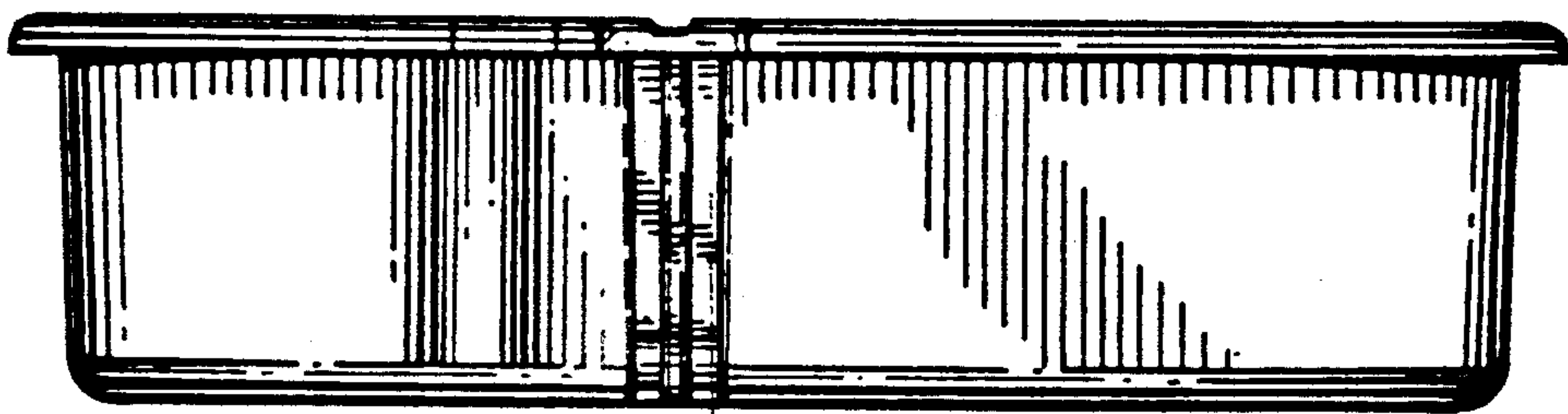

FIG. 4.

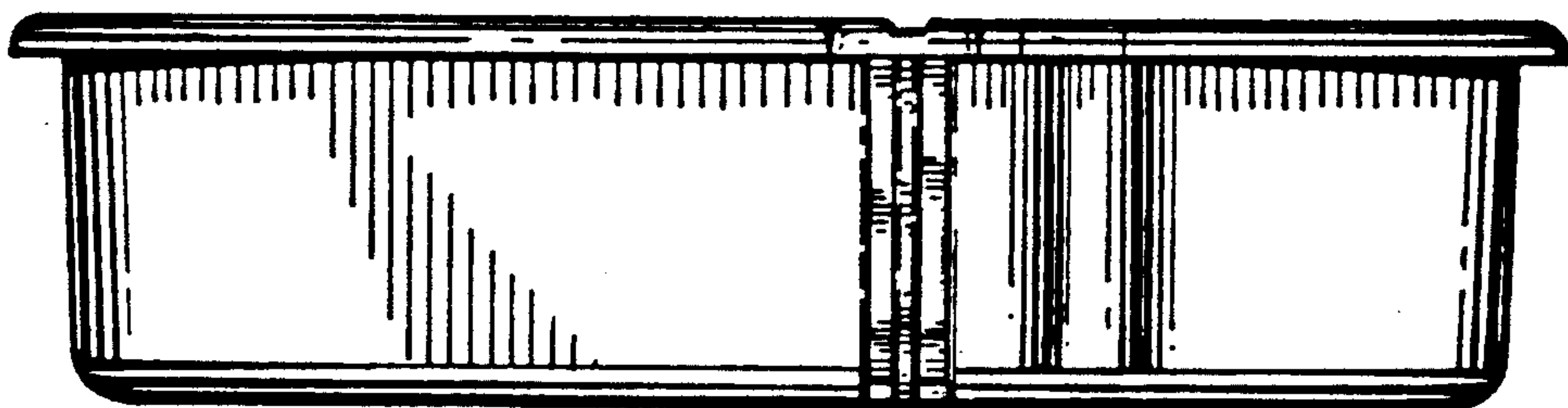

FIG. 5.

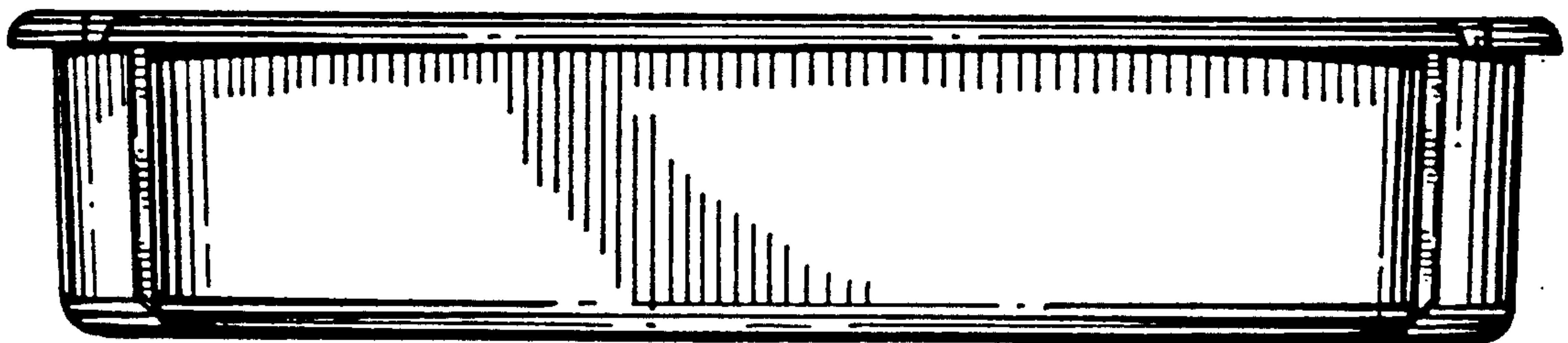

FIG. 6.

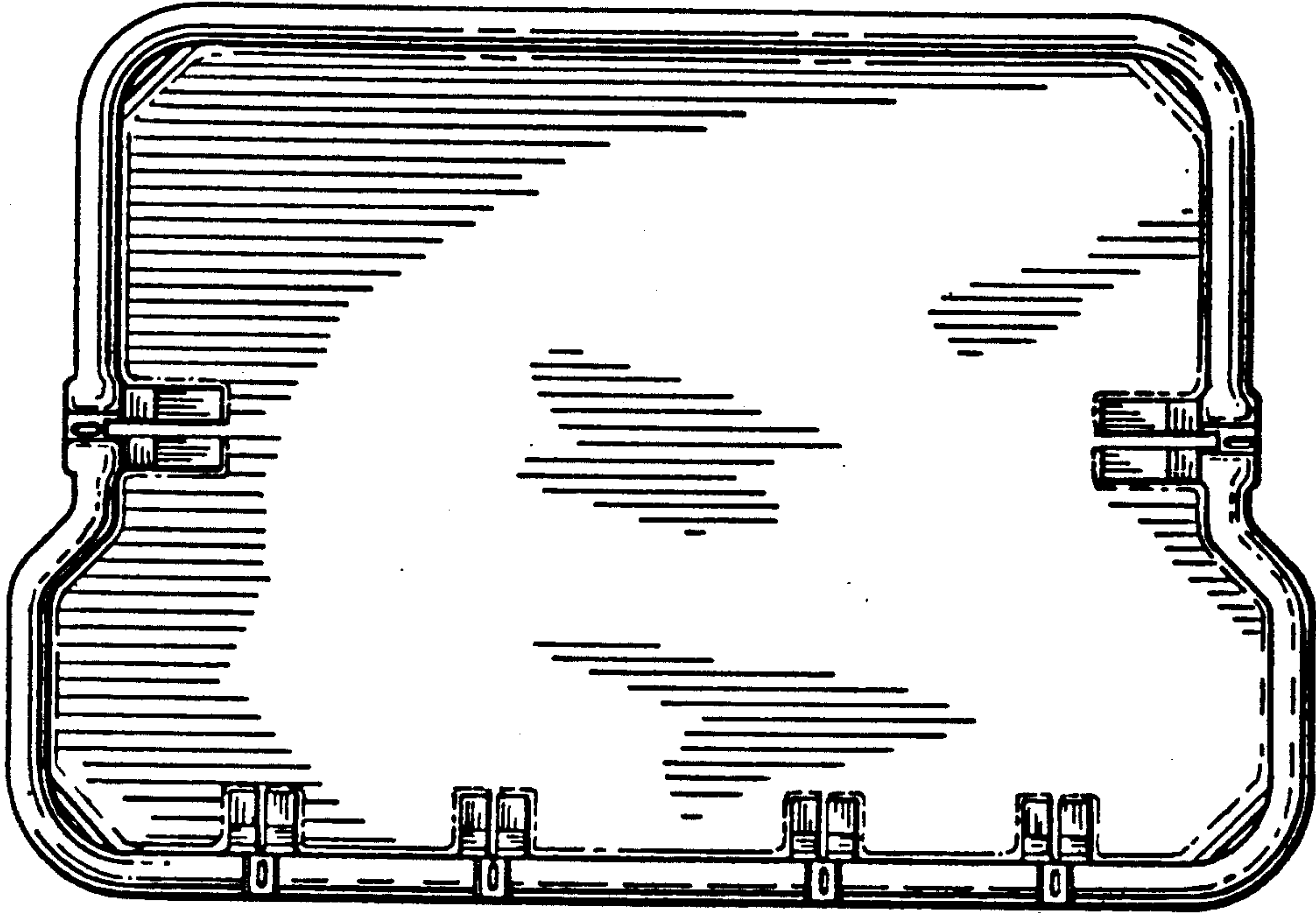

FIG. 7

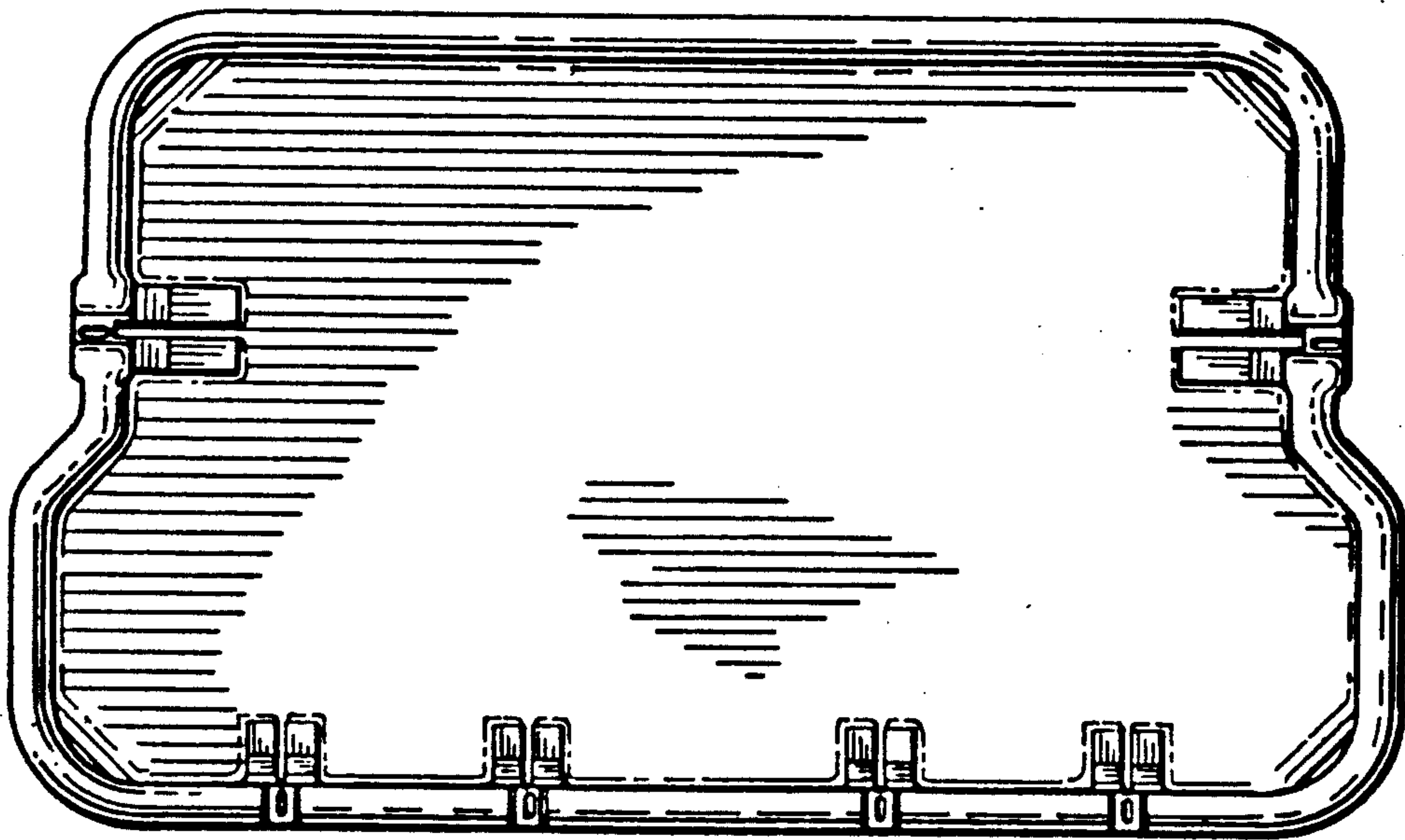

FIG. 8

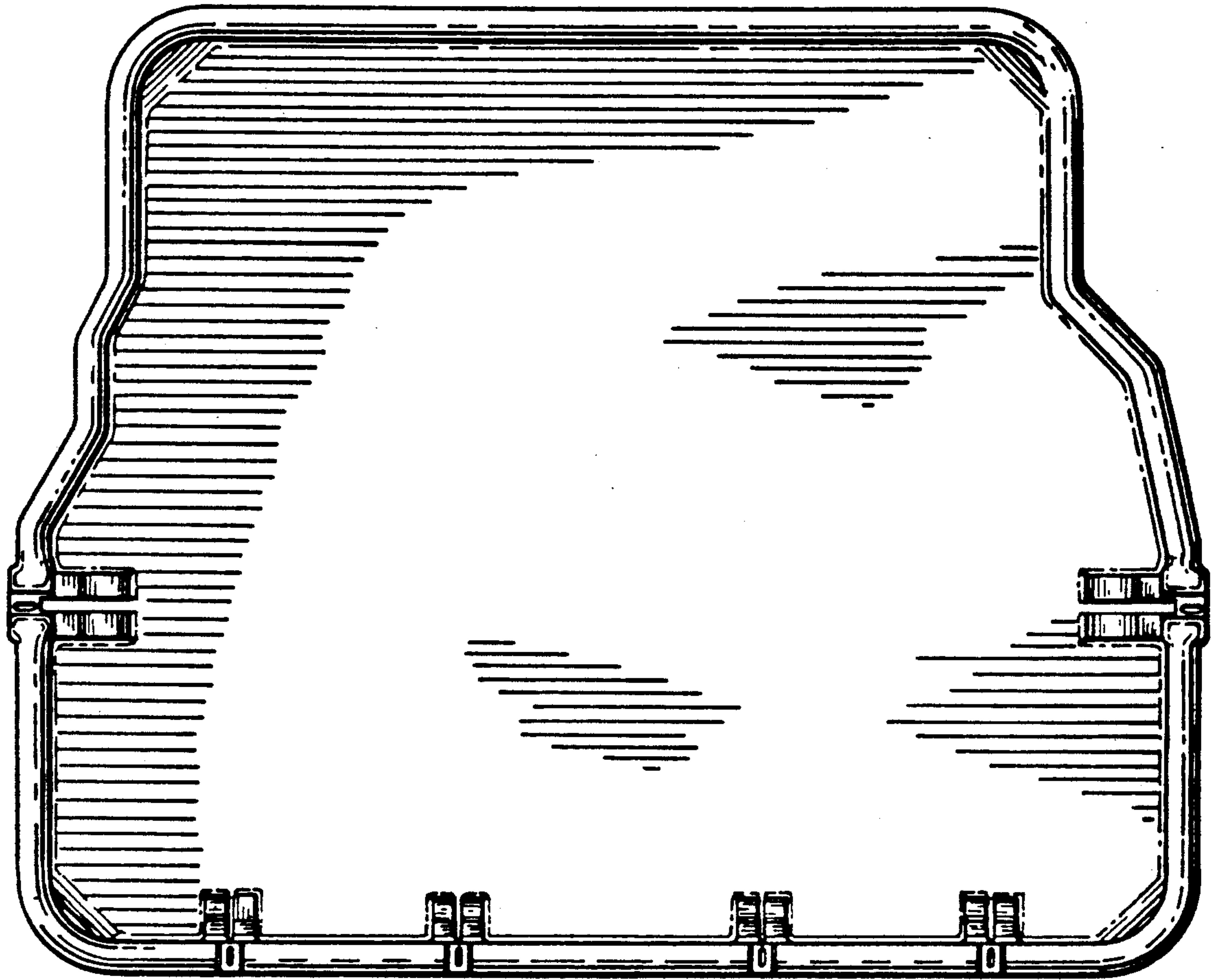

FIG. 9

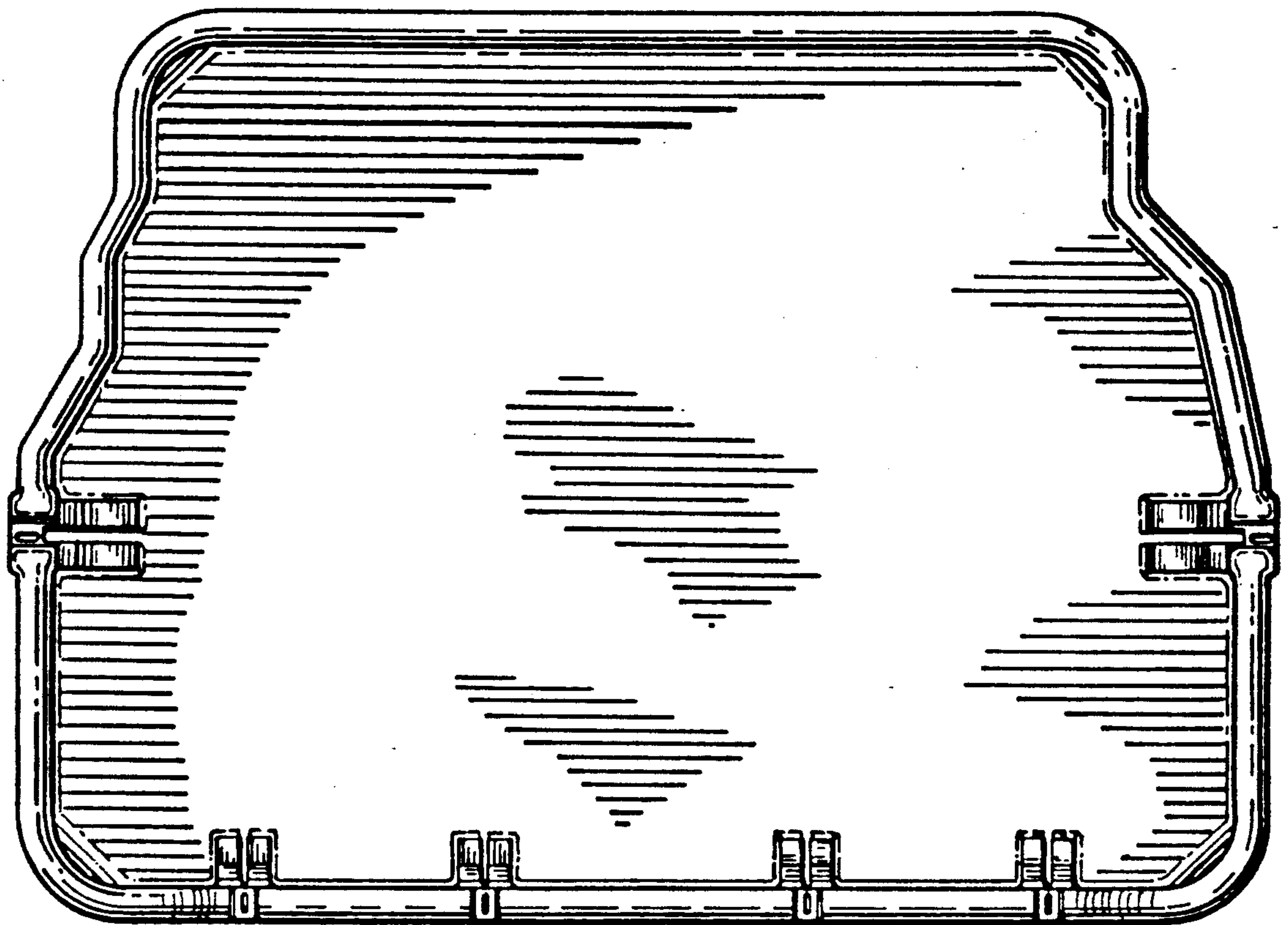

FIG. 10

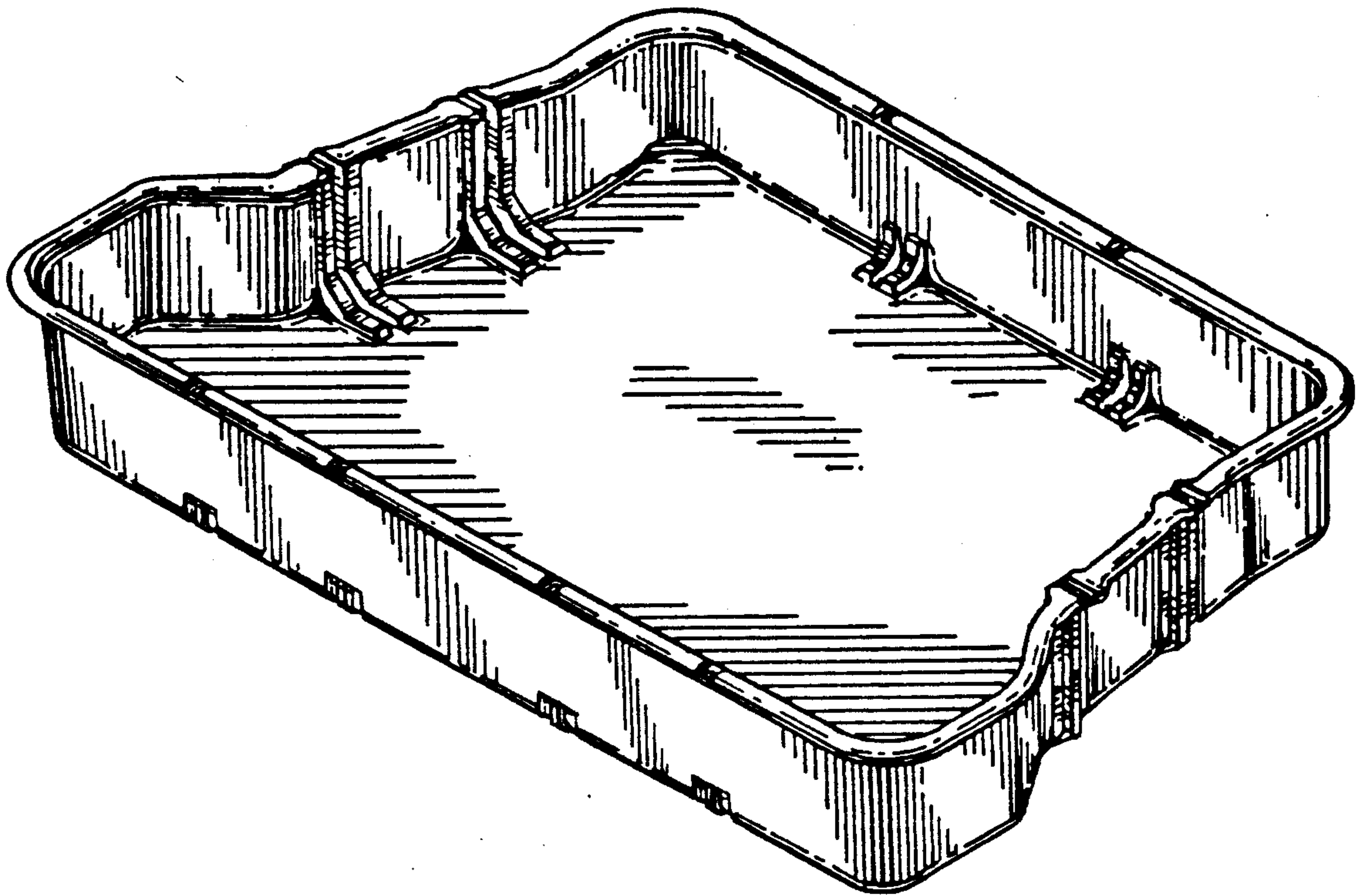

FIG. 11

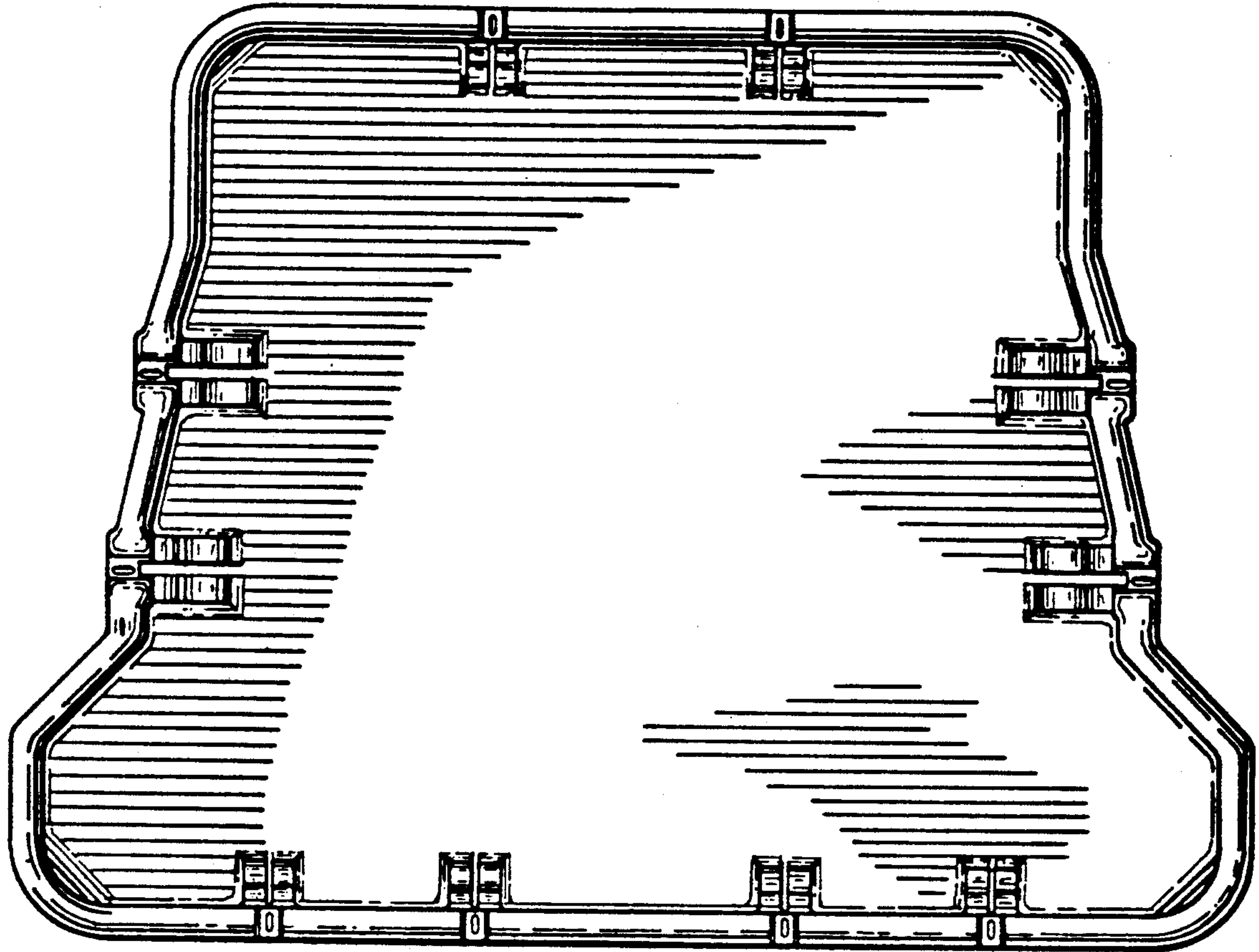

FIG. 12

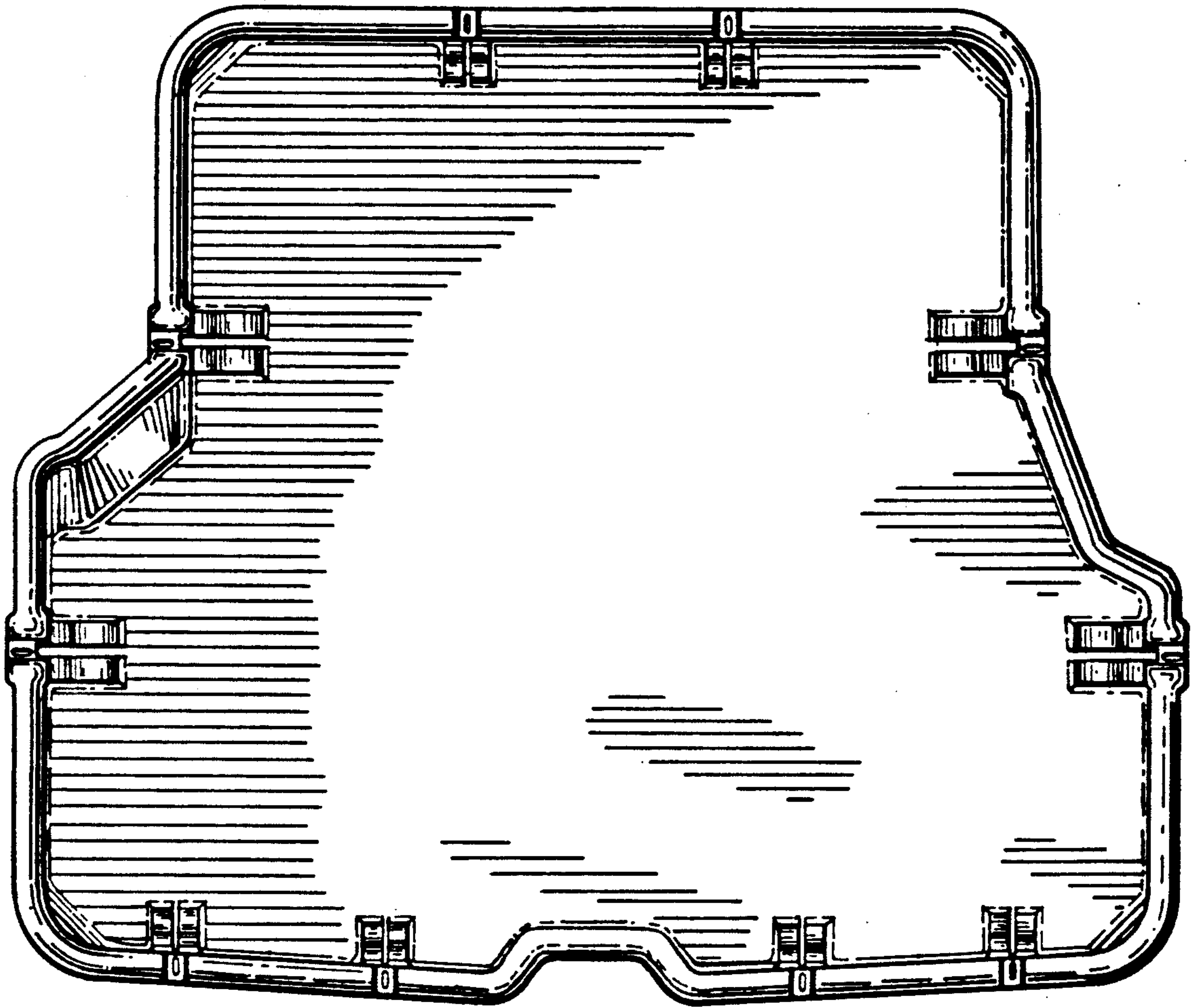

FIG. 13

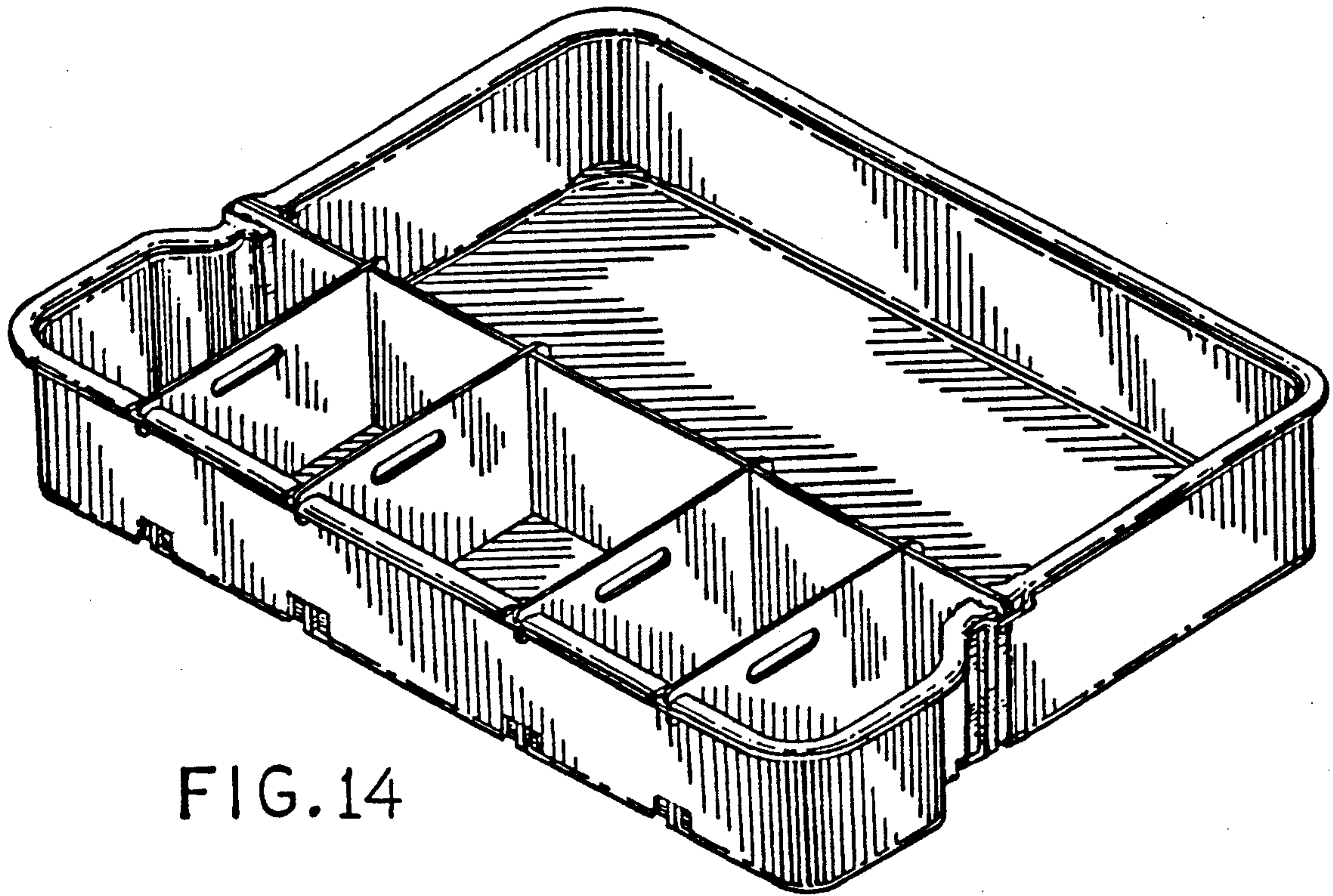

FIG. 14

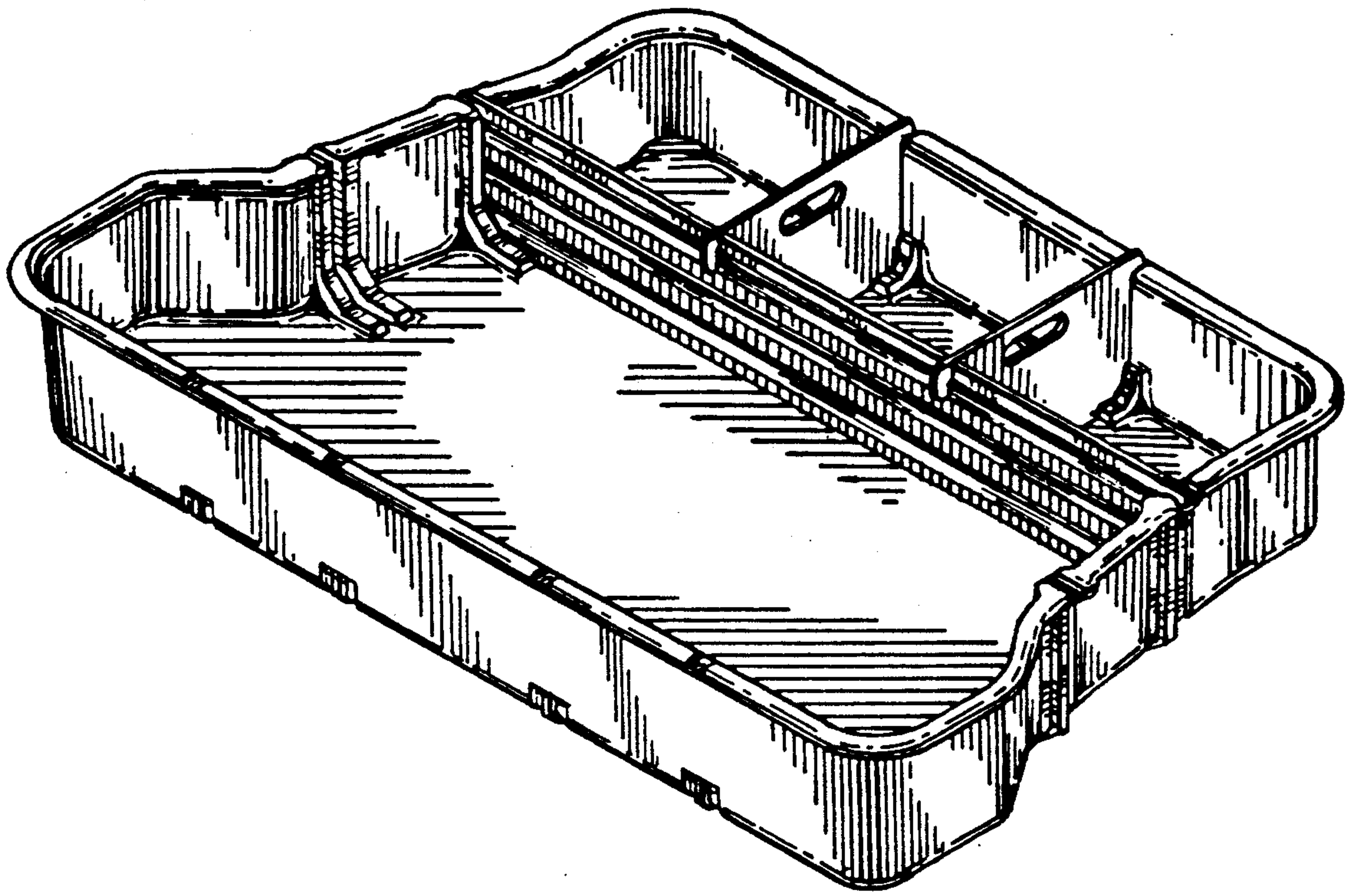

FIG. 15

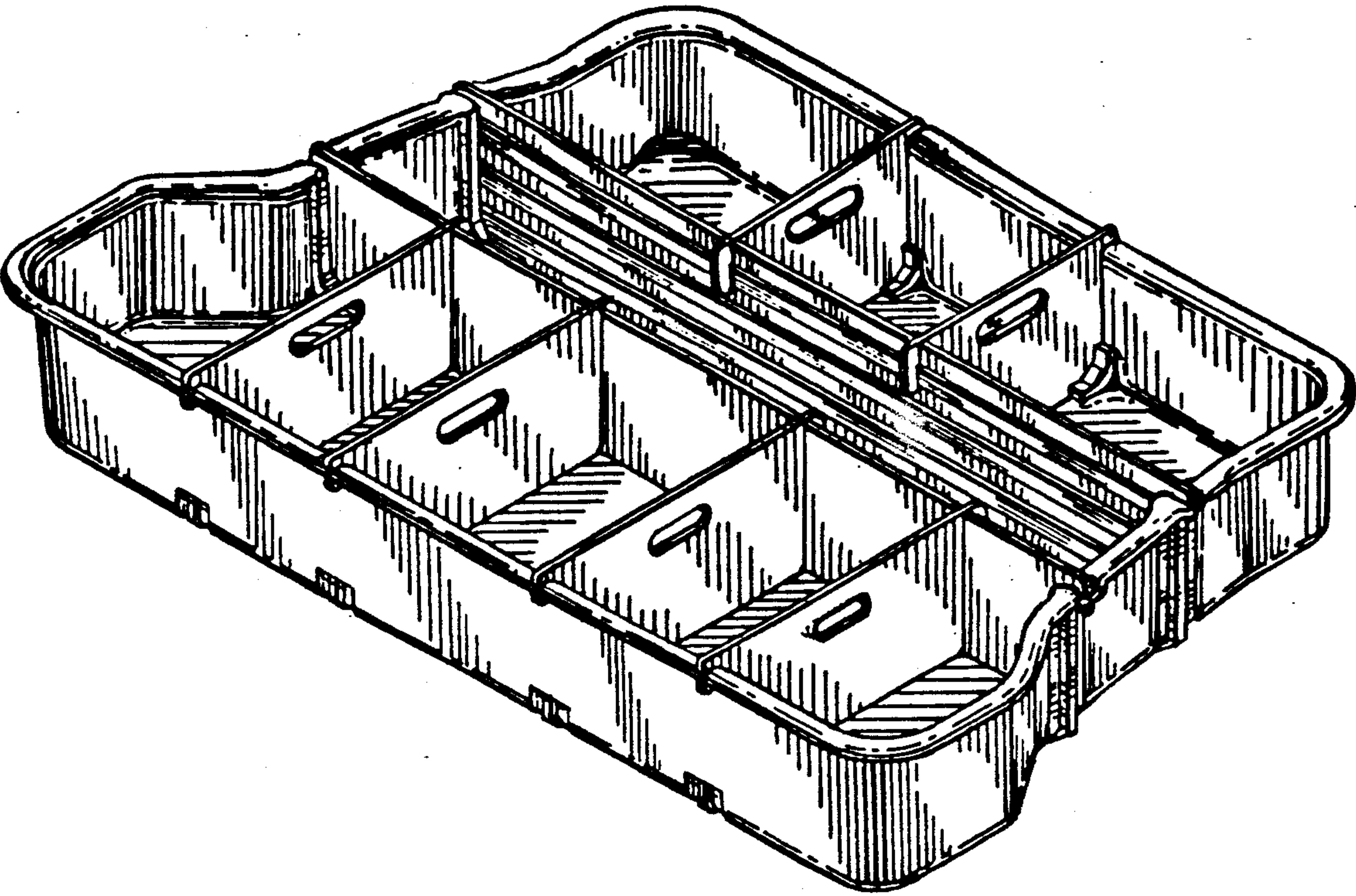

FIG. 16

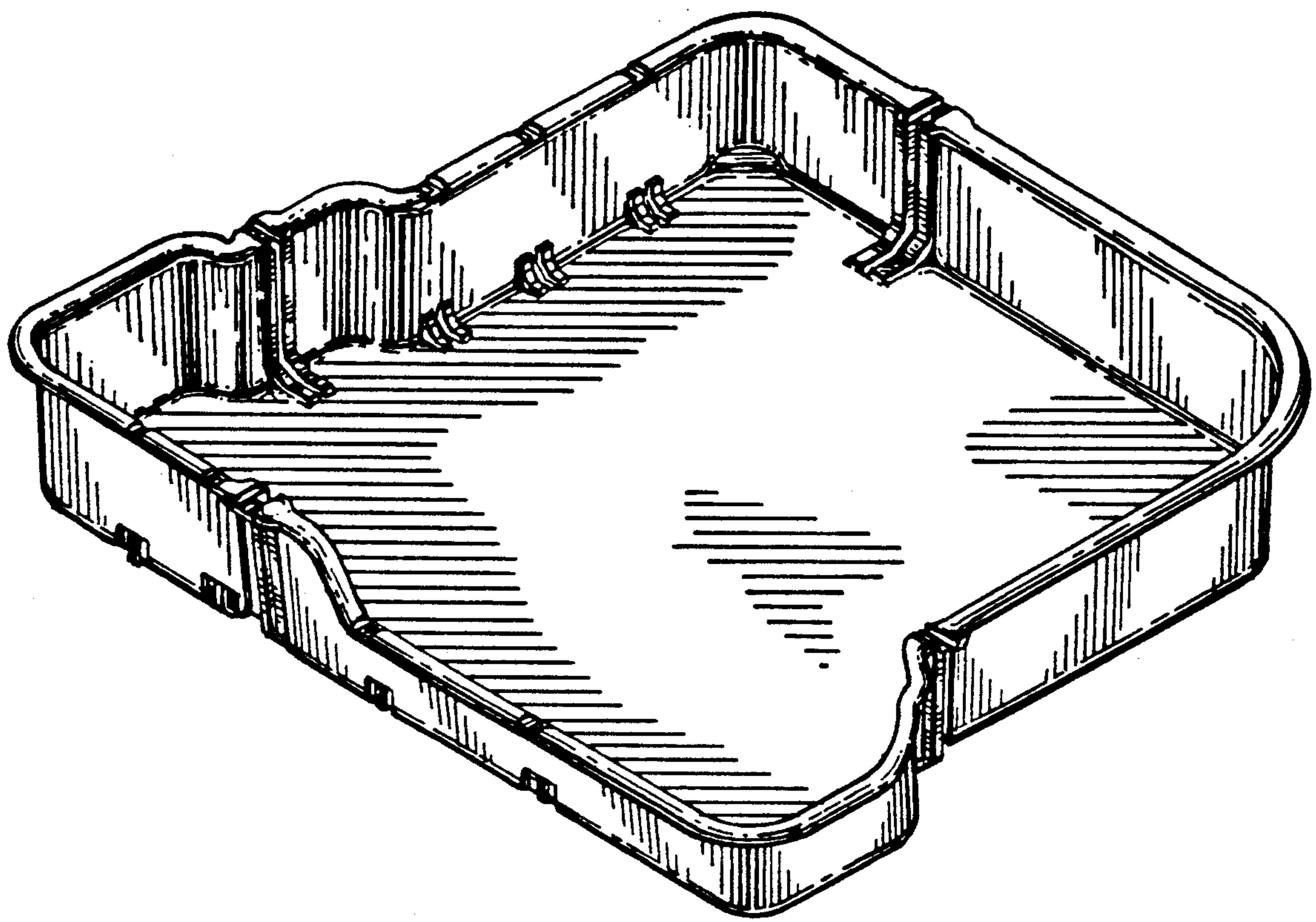

FIG. 17

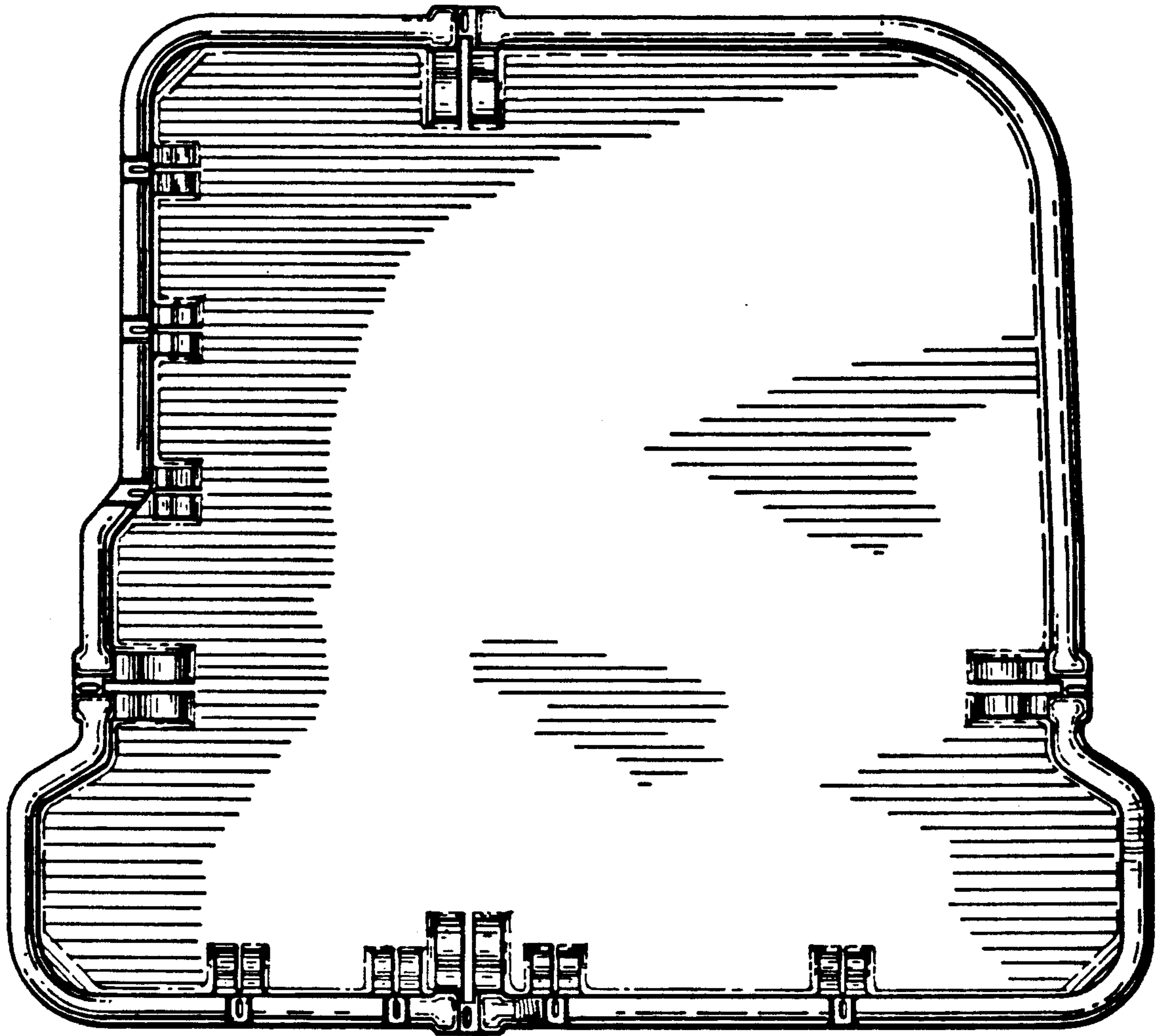

FIG. 18

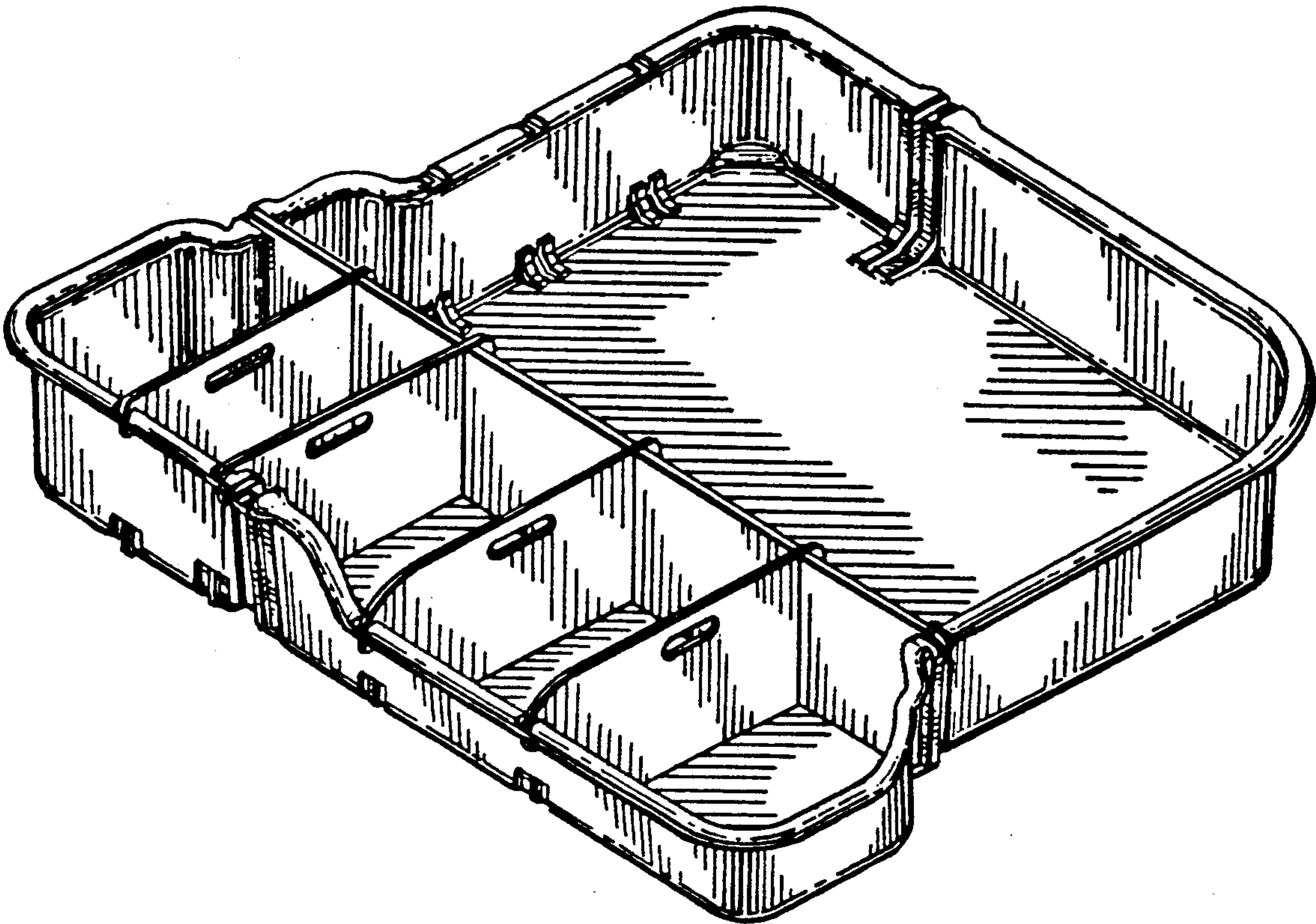

FIG.19

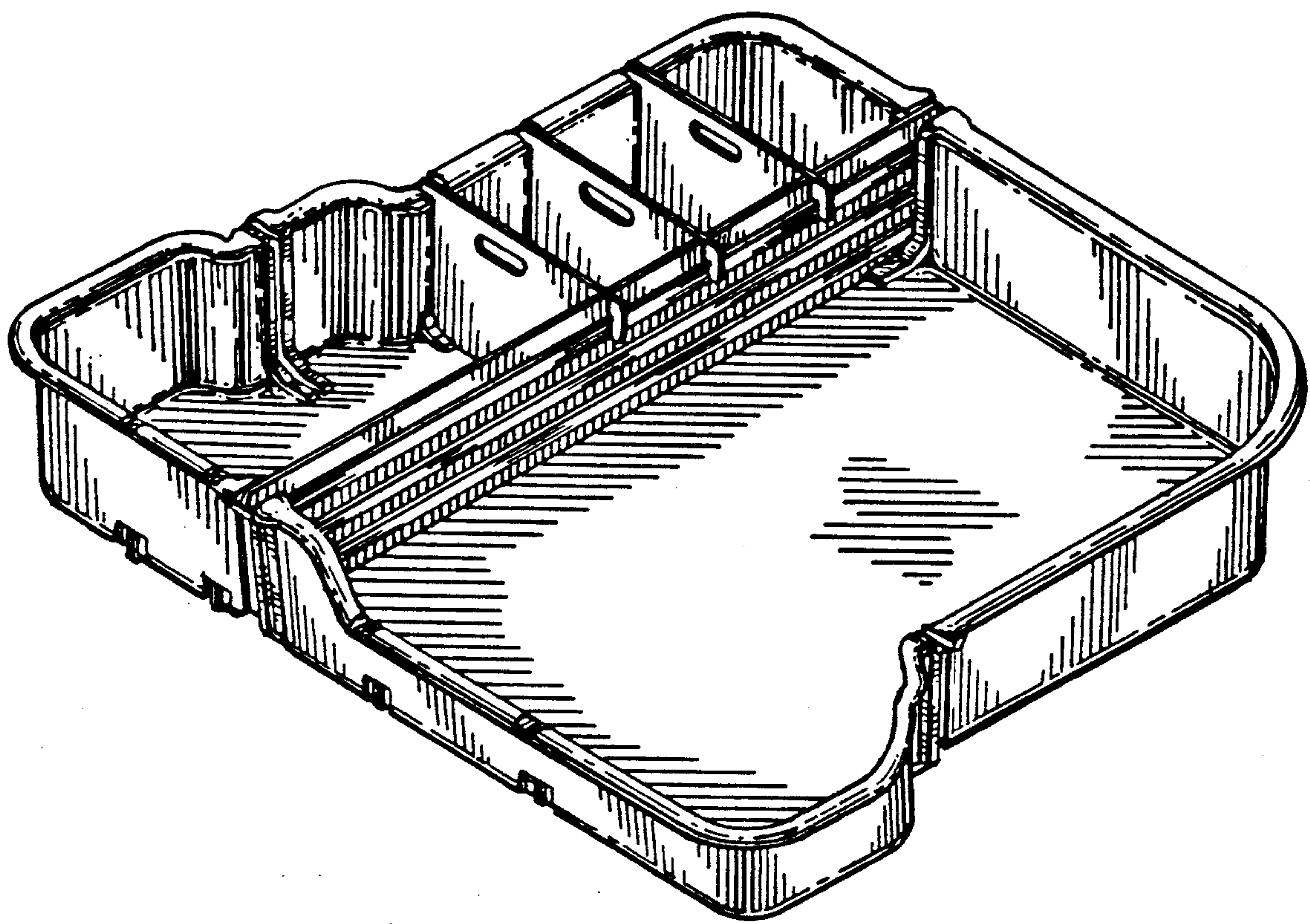

FIG. 20