



US00D344472S

United States Patent [19] Savio

[11] Patent Number: **Des. 344,472**

[45] Date of Patent: **** Feb. 22, 1994**

[54] **TRUCK**

[75] Inventor: **Piero Savio, Borgaretto, Italy**

[73] Assignee: **Iveco Fiat S.p.A., Turin, Italy**

[**] Term: **14 Years**

[21] Appl. No.: **747,792**

[22] Filed: **Aug. 19, 1991**

[30] **Foreign Application Priority Data**

Feb. 28, 1991 [IT] Italy T0910 000043

[52] U.S. Cl. **D12/96**

[58] Field of Search 296/181, 183, 190;
180/89.12, 89.19; D12/96, 98

[56] **References Cited**

U.S. PATENT DOCUMENTS

D. 323,134 1/1992 Lechner D12/96

OTHER PUBLICATIONS

Commercial Carrier Journal, Aug. 1989, p. 44, Mitsubishi Fuso Truck, top of page.

Commercial Carrier Journal, Feb. 1989, p. 75, UD Truck, top of page.

Commercial Carrier Journal, Mar. 1989, pp. 123 & 124, G. M. Truck, bottom of page.

Primary Examiner—James M. Gandy
Attorney, Agent, or Firm—Kane, Dalsimer, Sullivan, Kurucz, Levy, Eisele & Richard

[57] **CLAIM**

The ornamental design for a truck, as shown and described.

DESCRIPTION

FIG. 1 is a front elevational view of a truck showing my design;

FIG. 2 is a rear elevational view thereof;

FIG. 3 is a left side elevational view thereof;

FIG. 4 is a right side elevational view thereof;

FIG. 5 is a top plan view thereof;

FIG. 6 is a right front perspective view thereof;

FIG. 7 is a left front perspective view thereof;

FIG. 8 is front elevational view of a truck a second embodiment of my design;

FIG. 9 is a rear elevational view of FIG. 9;

FIG. 10 is a left side elevational view of FIG. 9;

FIG. 11 is a right side elevational view of FIG. 9;

FIG. 12 is a top plan view of FIG. 9; and,

FIG. 13 is a right front perspective view of FIG. 9.

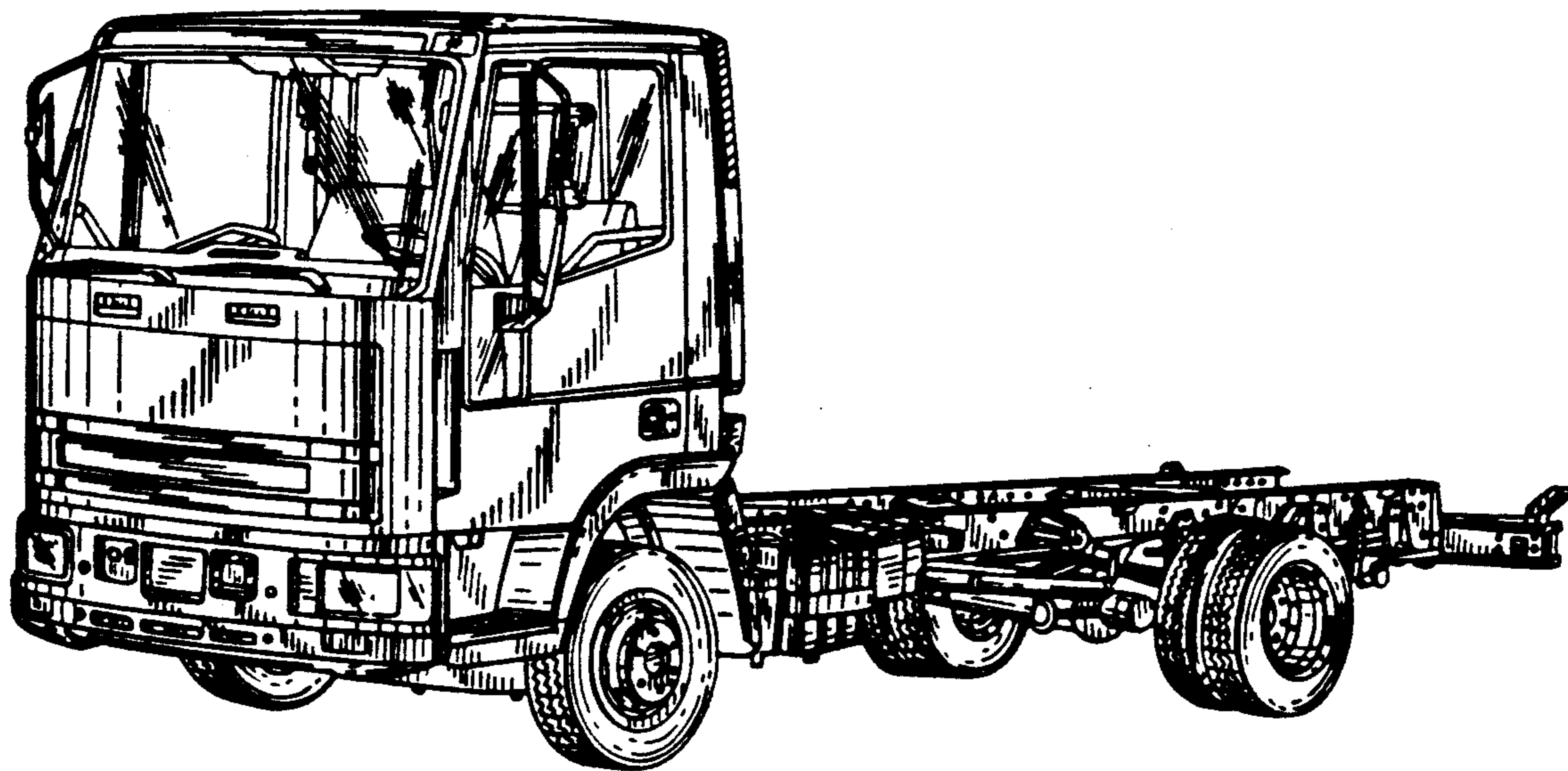

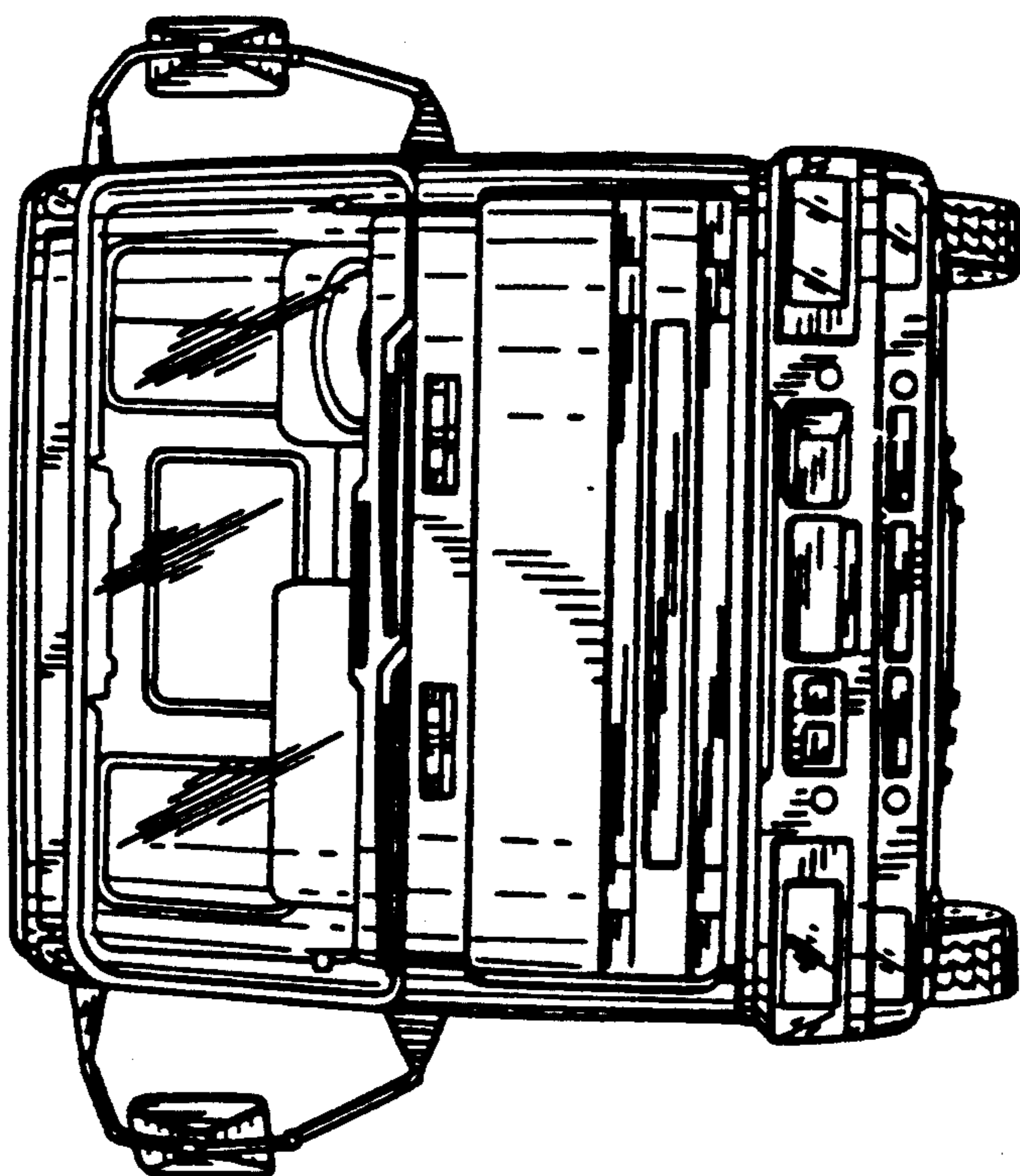

FIG. 1

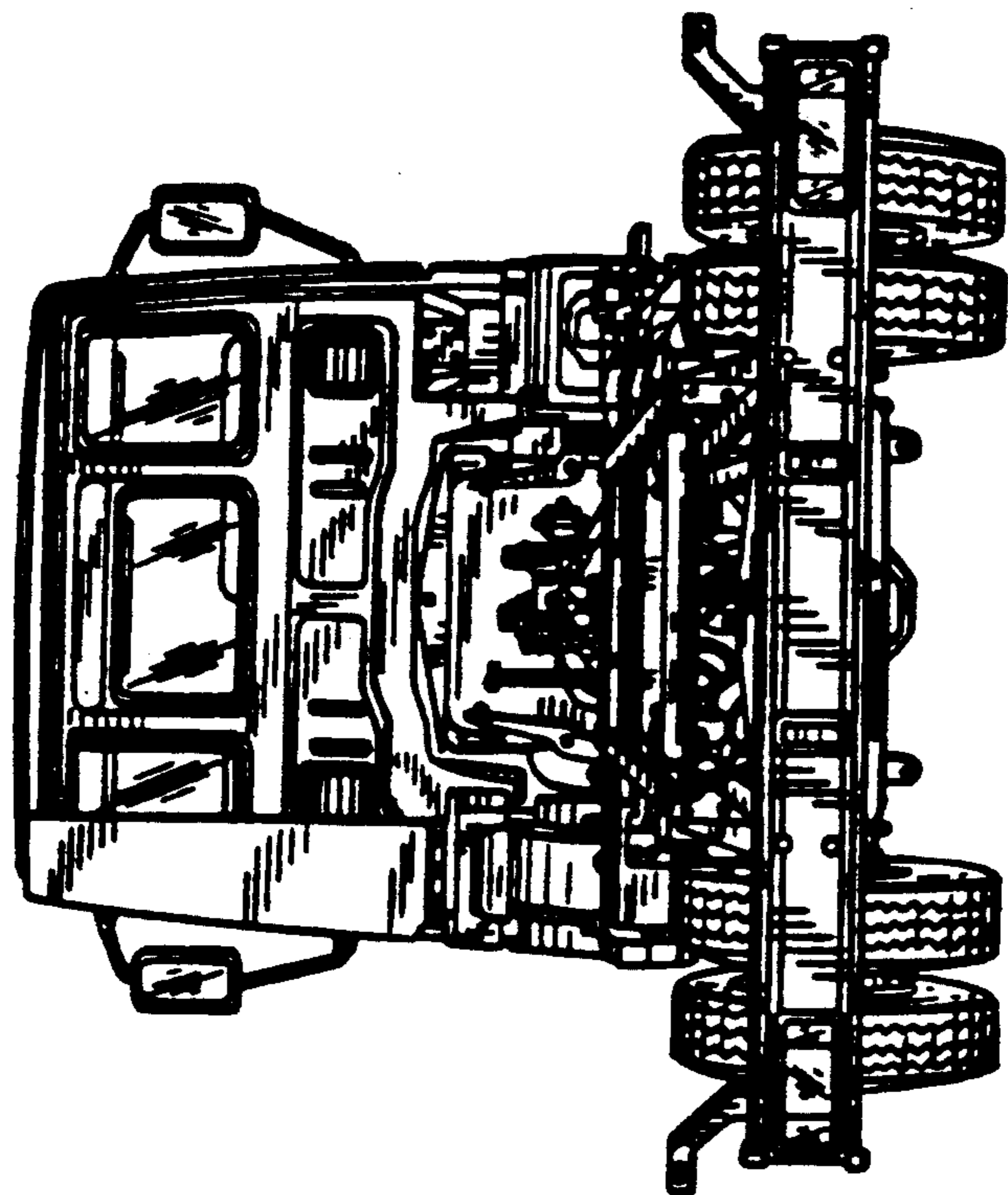

FIG. 2

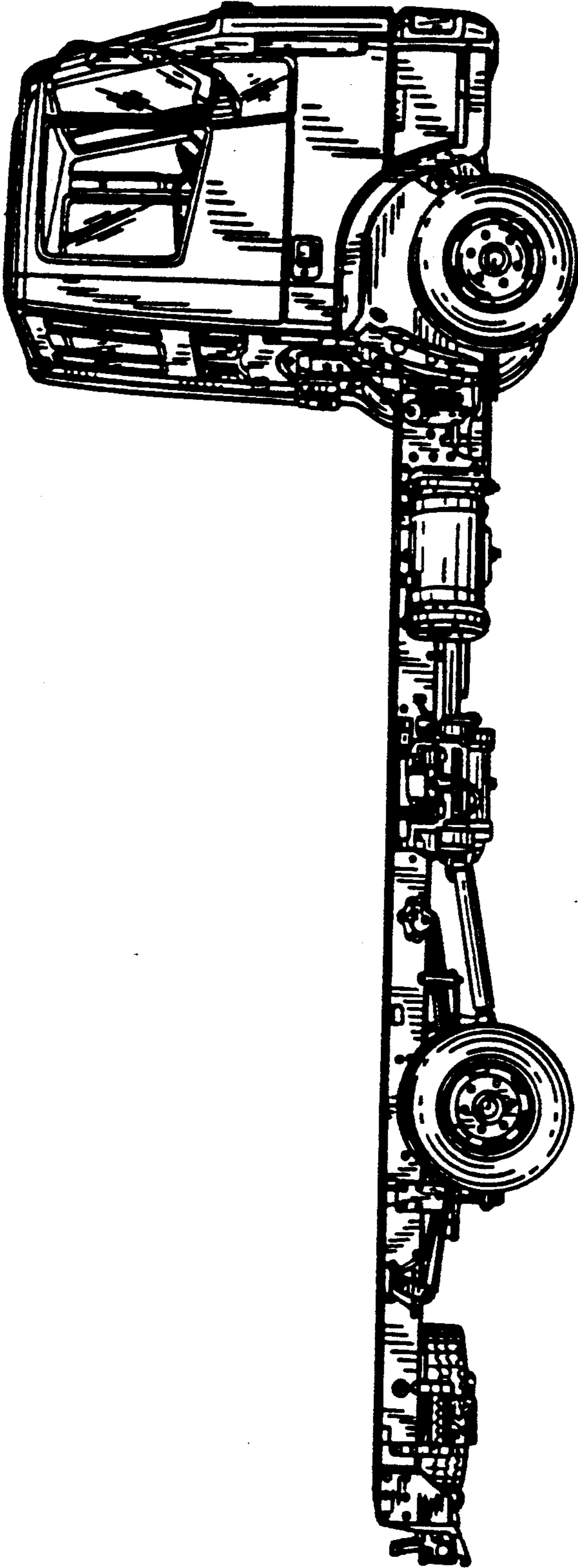

FIG. 3

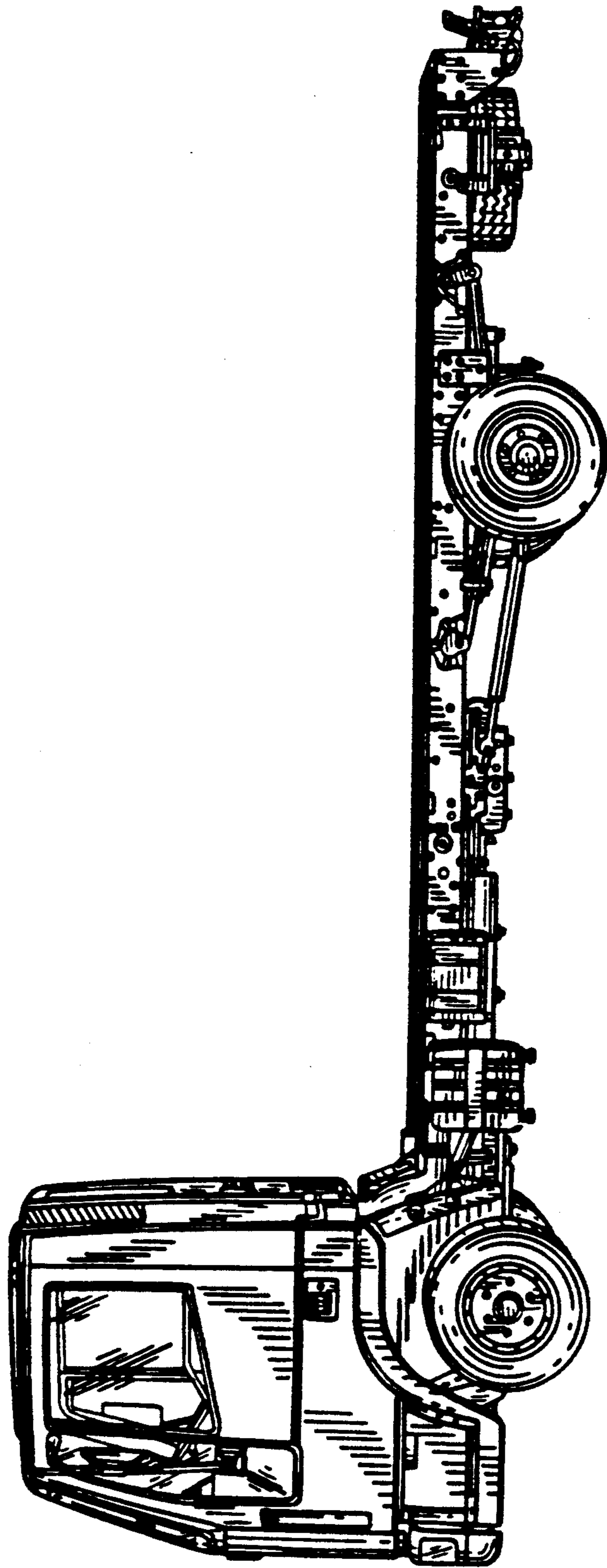

FIG. 4

FIG. 5

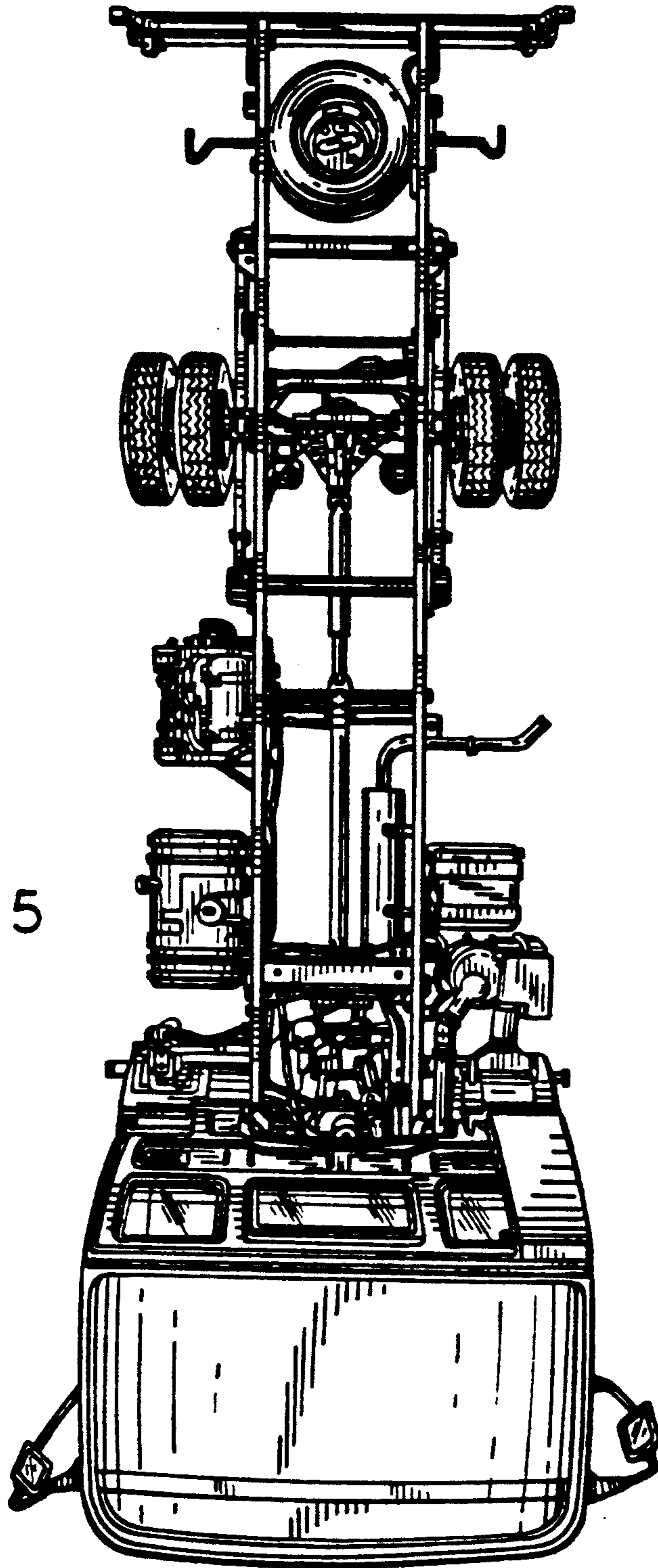
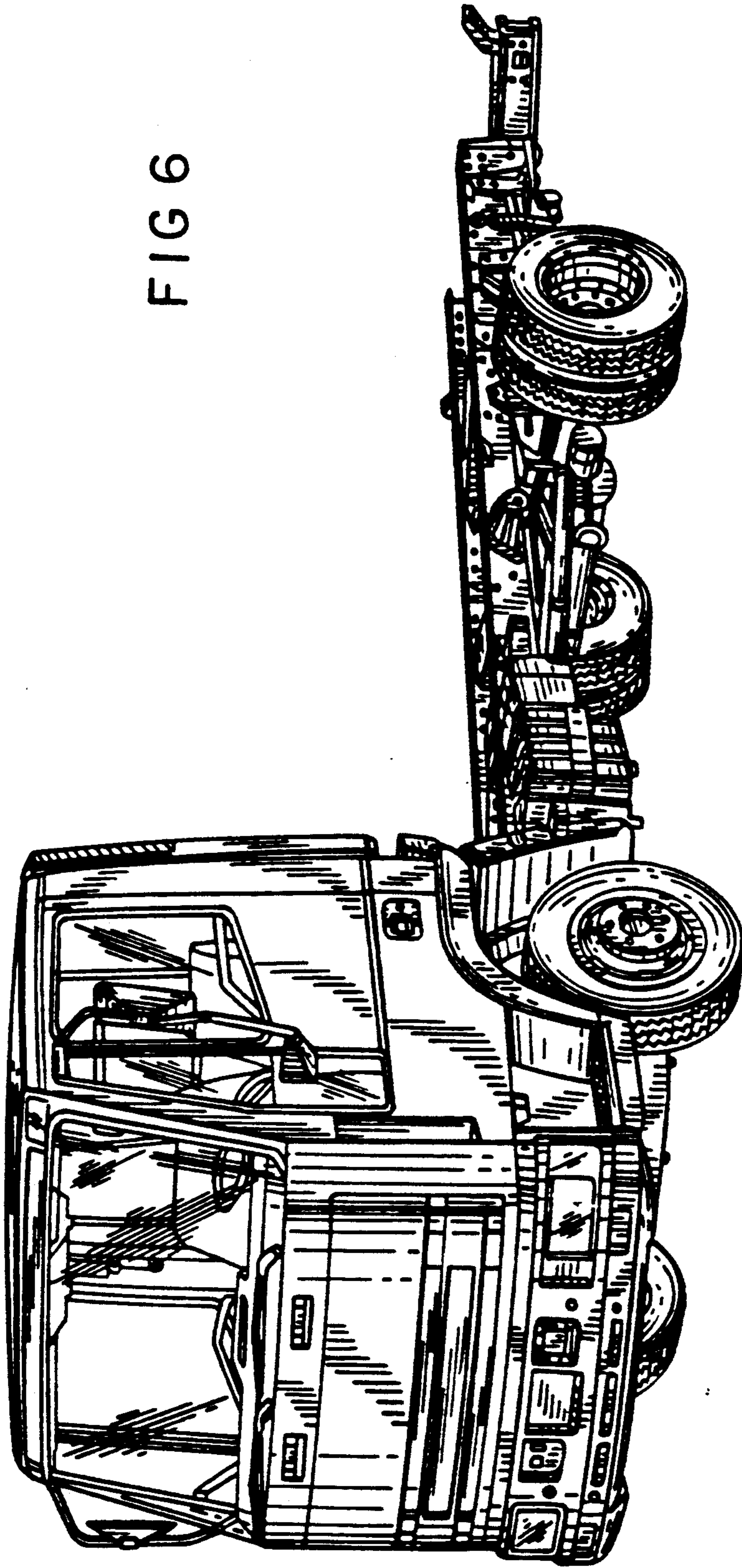

FIG 6



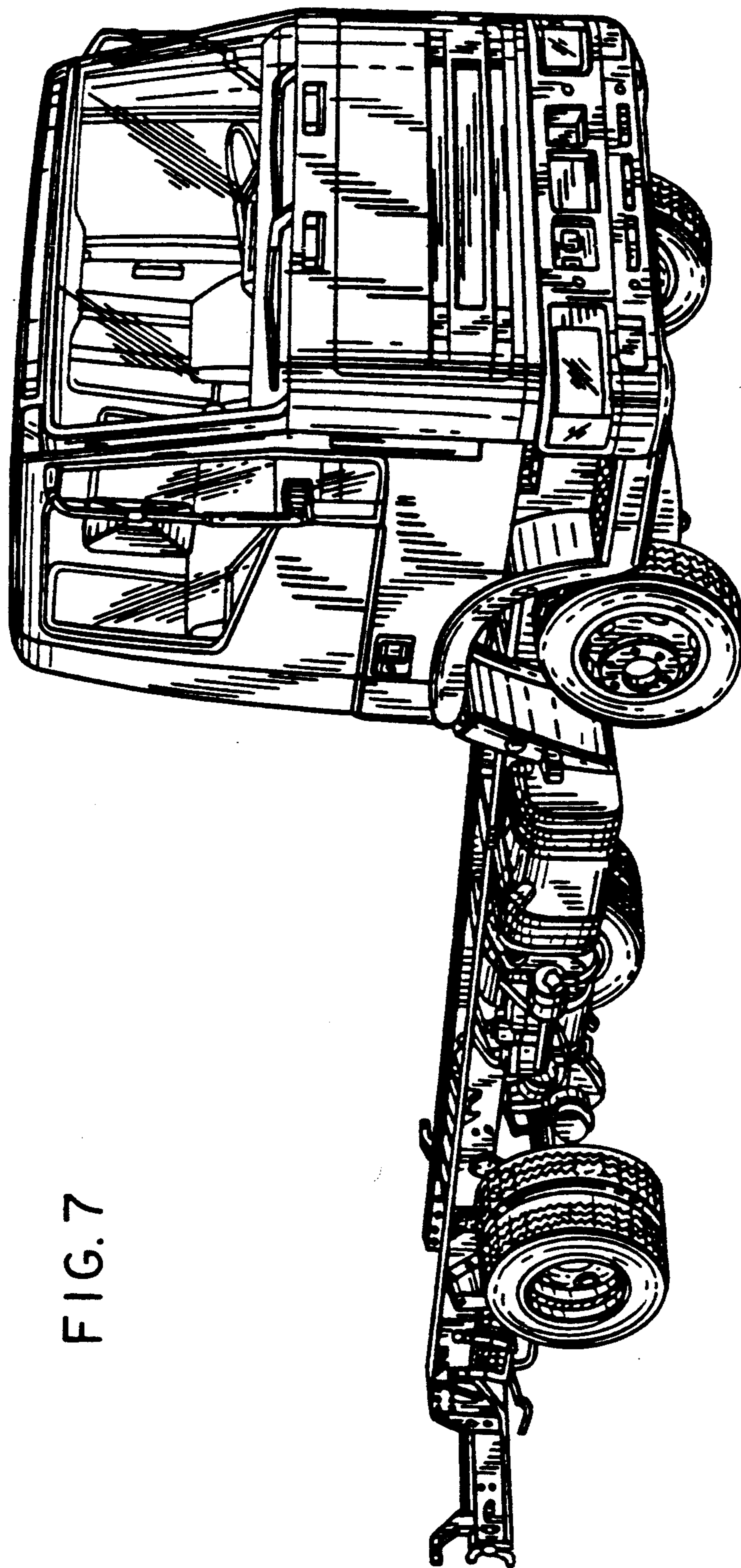

FIG. 7

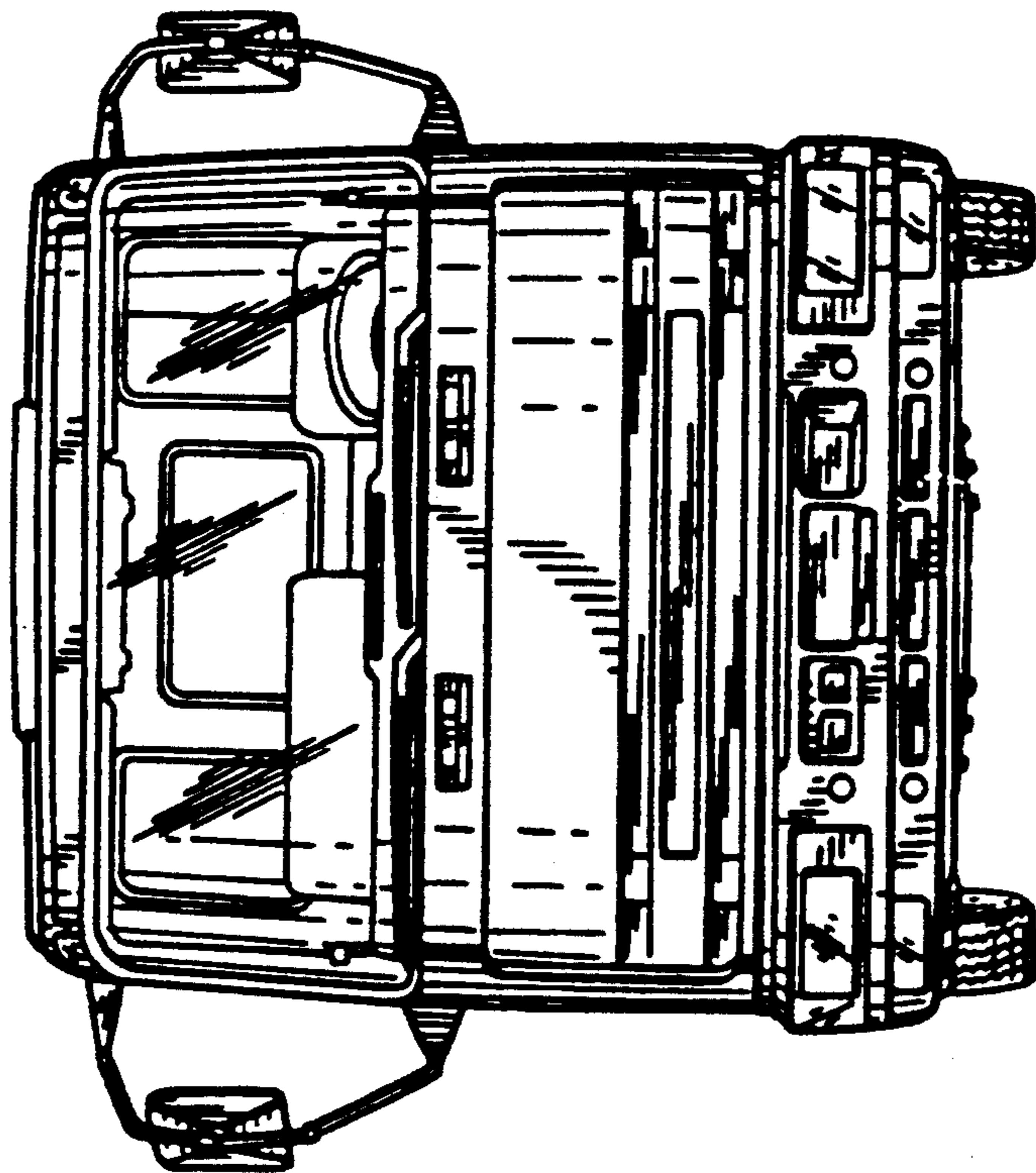

FIG. 8

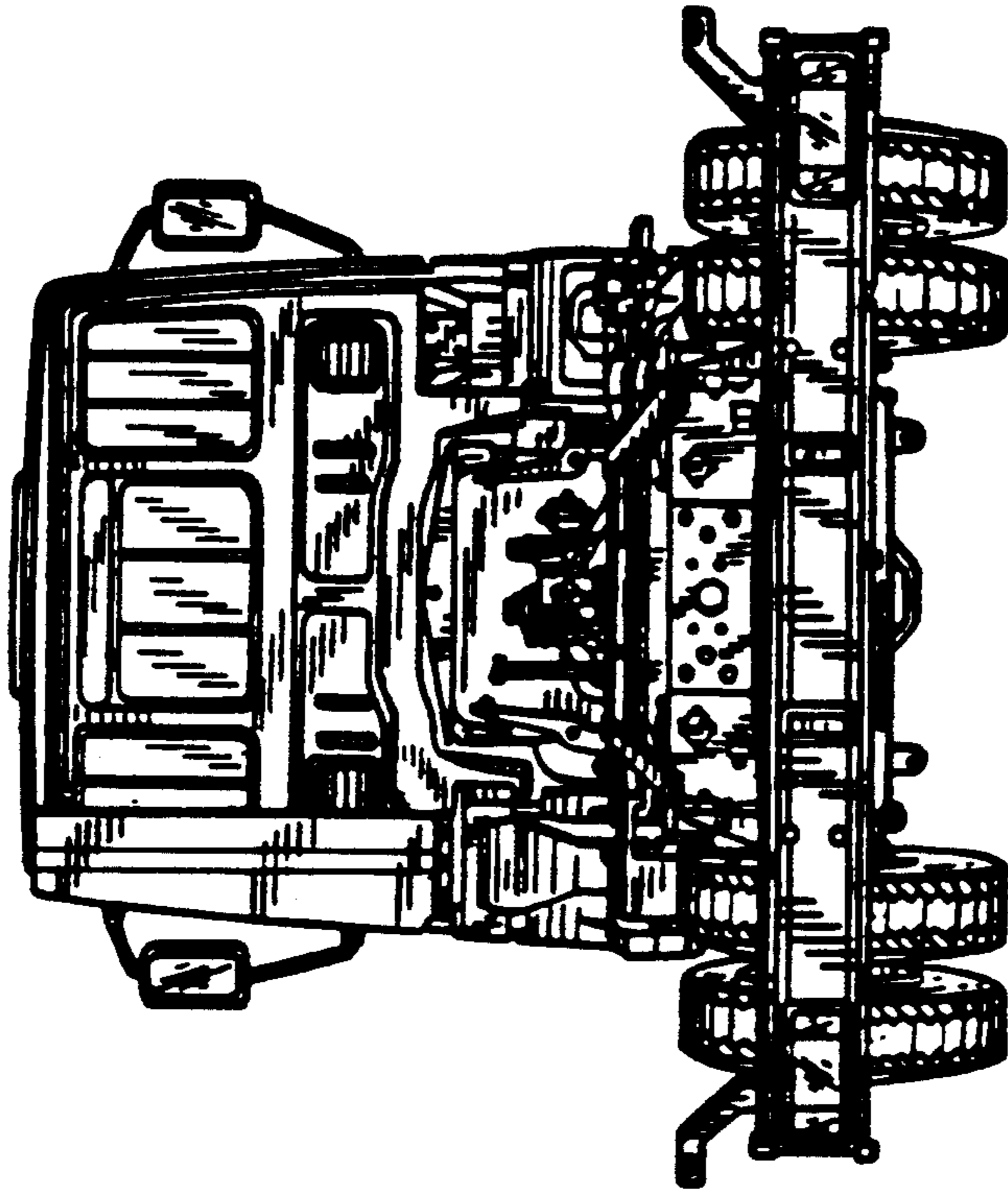

FIG. 9

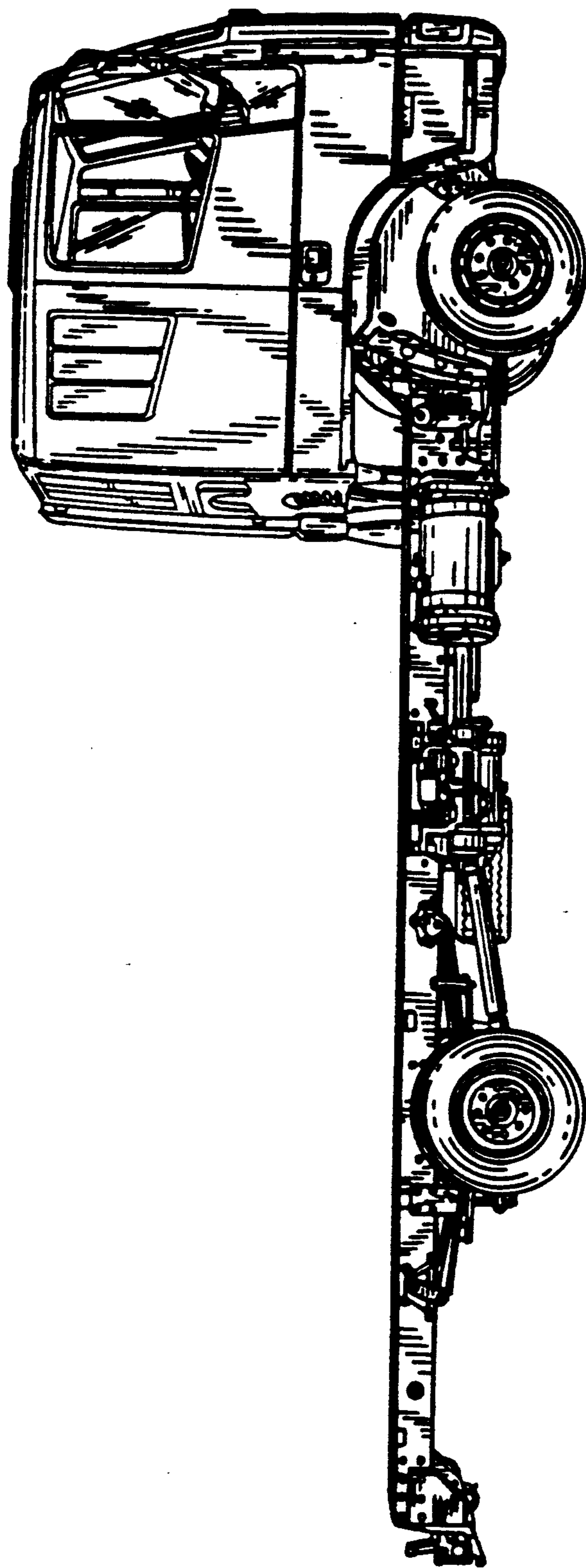

FIG. 10

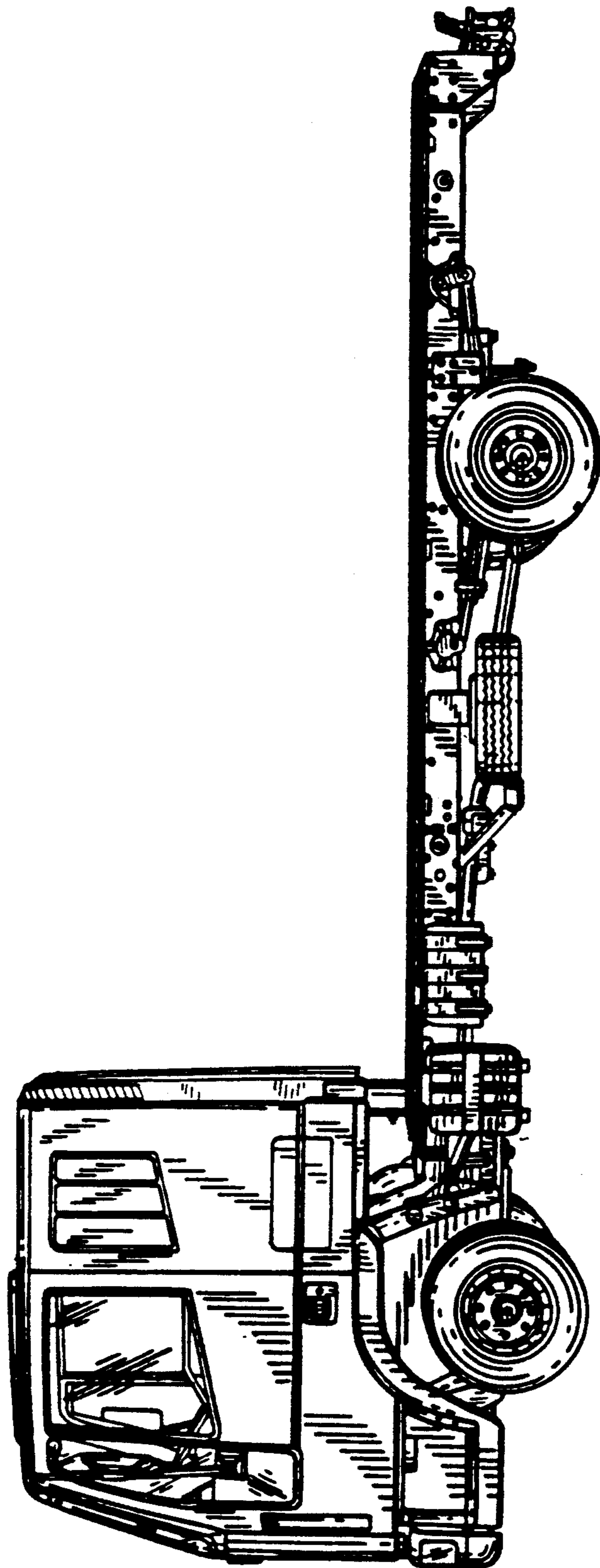

FIG. II

FIG. 12

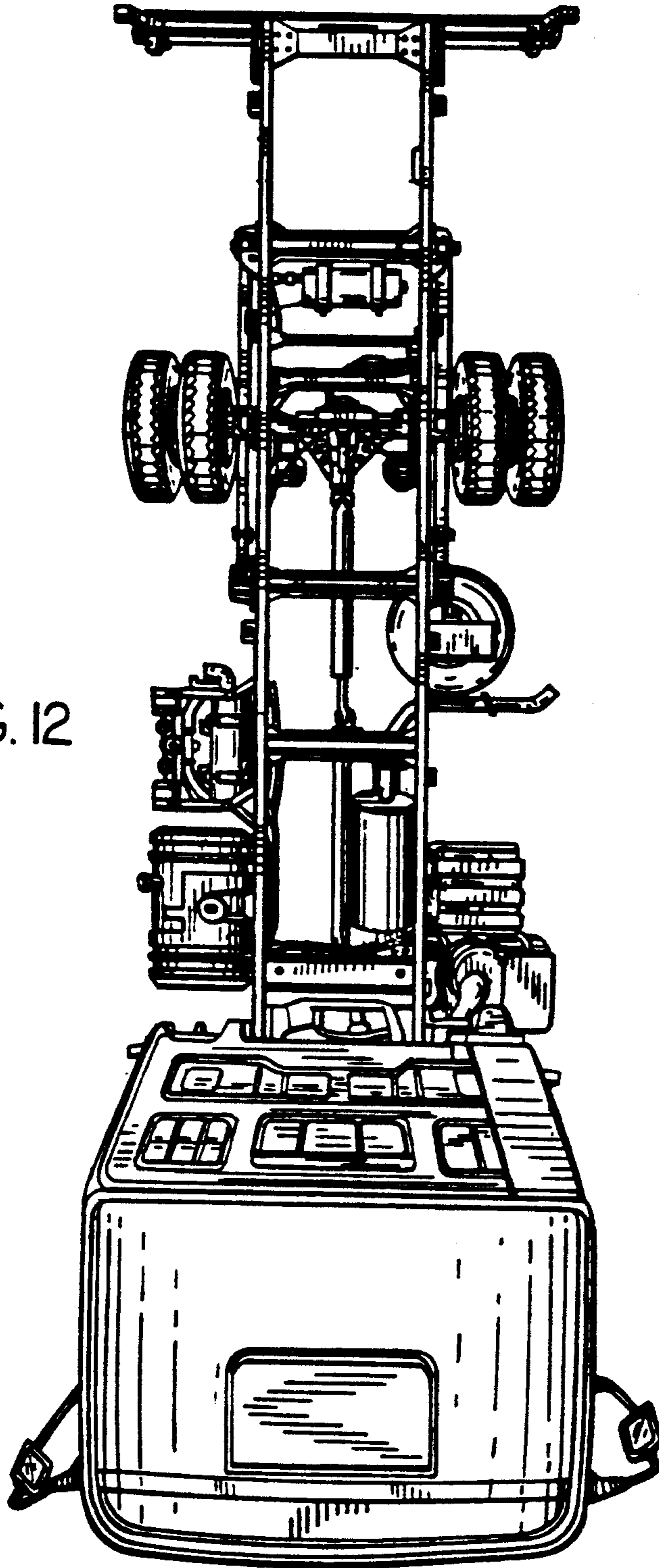

FIG. 13

