



US00D344424S

United States Patent [19] Pate

[11] Patent Number: Des. 344,424

[45] Date of Patent: ** Feb. 22, 1994

[54] SHELF

[76] Inventor: John S. Pate, 5339 Stonetrace,
Gainesville, Ga. 30501

[**] Term: 14 Years

[21] Appl. No.: 733,384

[22] Filed: Jul. 22, 1991

[52] U.S. CL D6/511; D25/119

[58] Field of Search D6/491, 509-511,
D6/475, 466, 462, 574, 555, 429, 566, 567, 572;
248/281.1; 211/88, 90, 126, 134, 135, 153;
108/137-139, 47, 49; D19/86, 92; D25/119

[56] References Cited

U.S. PATENT DOCUMENTS

- D. 51,509 11/1917 Plym D25/119
- D. 200,583 3/1965 Schaefer et al. .
- D. 201,808 8/1965 Yamasaki et al. .
- D. 239,231 3/1976 Cockcroft et al. .
- D. 239,232 3/1976 Cockcroft et al. .
- D. 244,499 5/1977 Parfitt .
- D. 245,273 8/1977 Pettersson D25/119
- D. 257,797 1/1981 Aprahamian .

- D. 299,194 1/1989 Pate .
- D. 306,670 3/1990 Pfleuger et al. .
- D. 311,657 10/1990 Pate D6/511 X
- D. 887,882 5/1908 Waugh .
- 2,915,193 12/1959 Bromberg .
- 3,135,388 6/1964 Lang .
- 3,863,575 2/1975 Kuns et al. .

Primary Examiner—Nelson C. Holtje
Assistant Examiner—J. E. Seeger
Attorney, Agent, or Firm—Jones & Askew

[57] CLAIM

The ornamental design for a shelf, as shown and described.

DESCRIPTION

FIG. 1 is a perspective view of a shelf, showing my new design, the broken lines are for environmental purposes only and form no part of the claimed design;
FIG. 2 is a top plan view thereof;
FIG. 3 is a front plan view thereof;
FIG. 4 is a lower plan view thereof;
FIG. 5 is a rear plan view thereof; and,
FIG. 6 is an end view thereof.

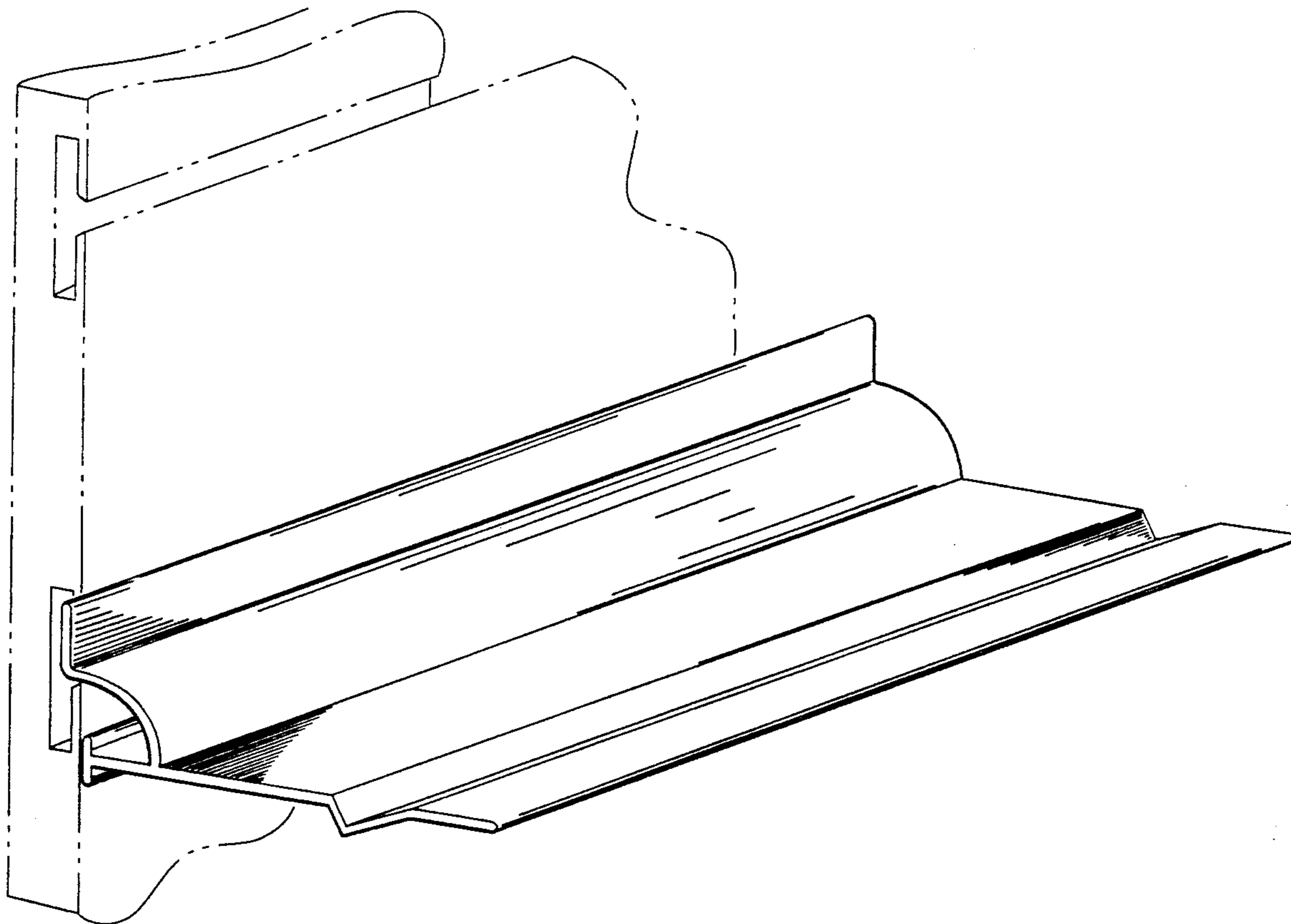

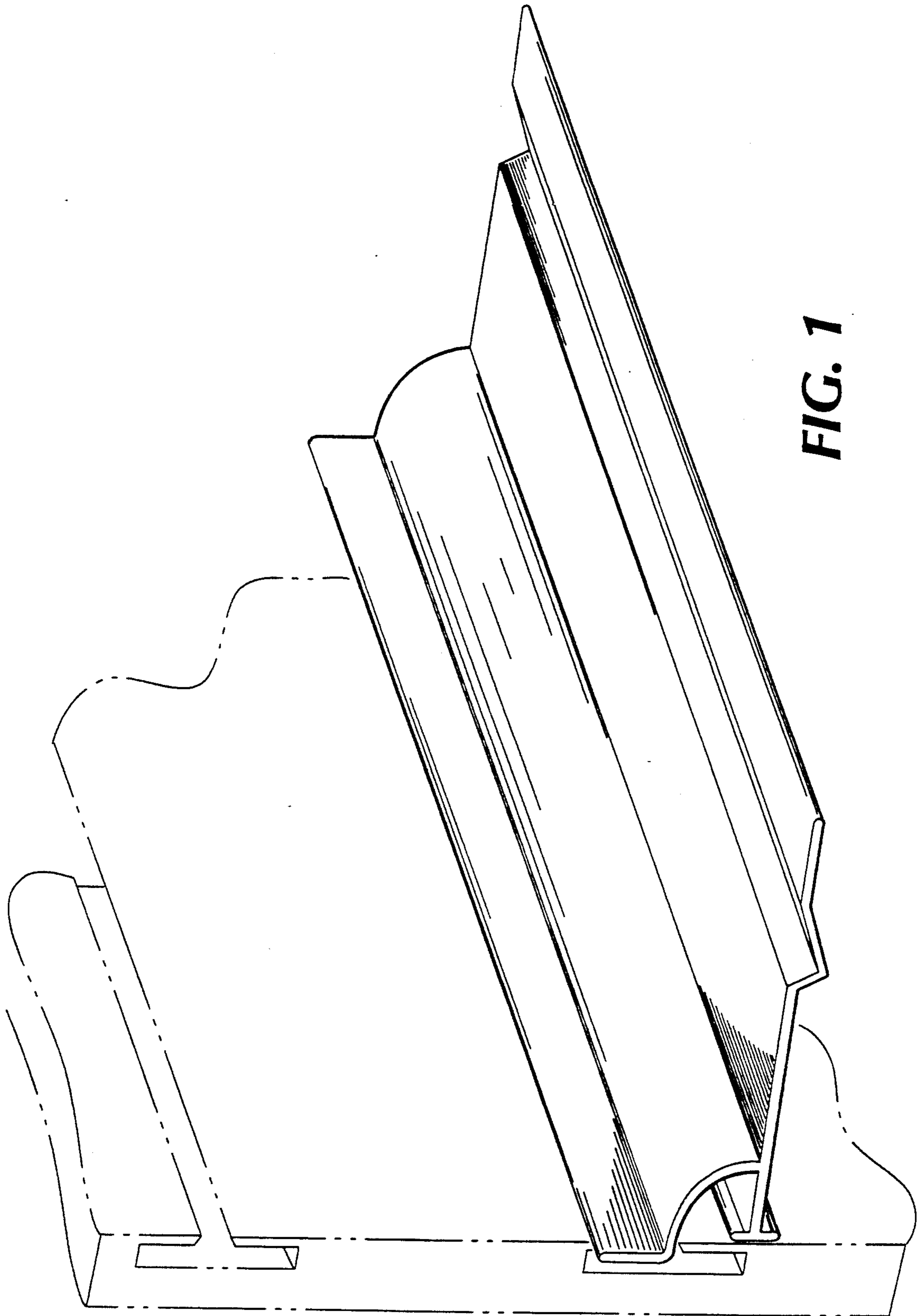

FIG. 1

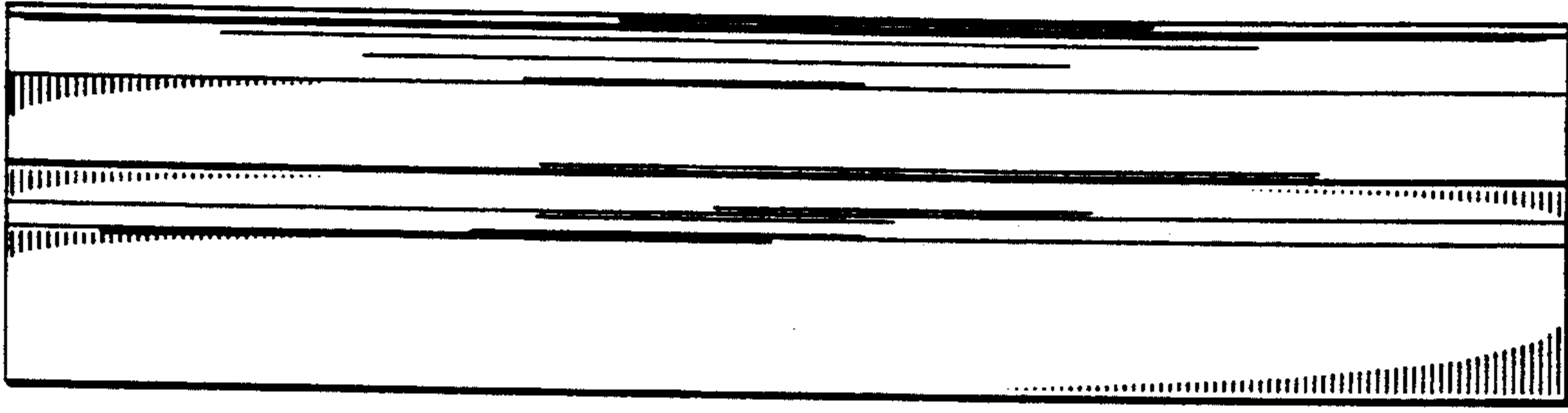

FIG. 2

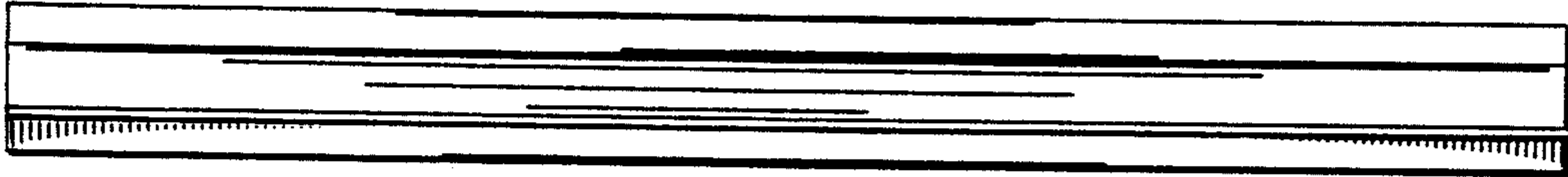

FIG. 3

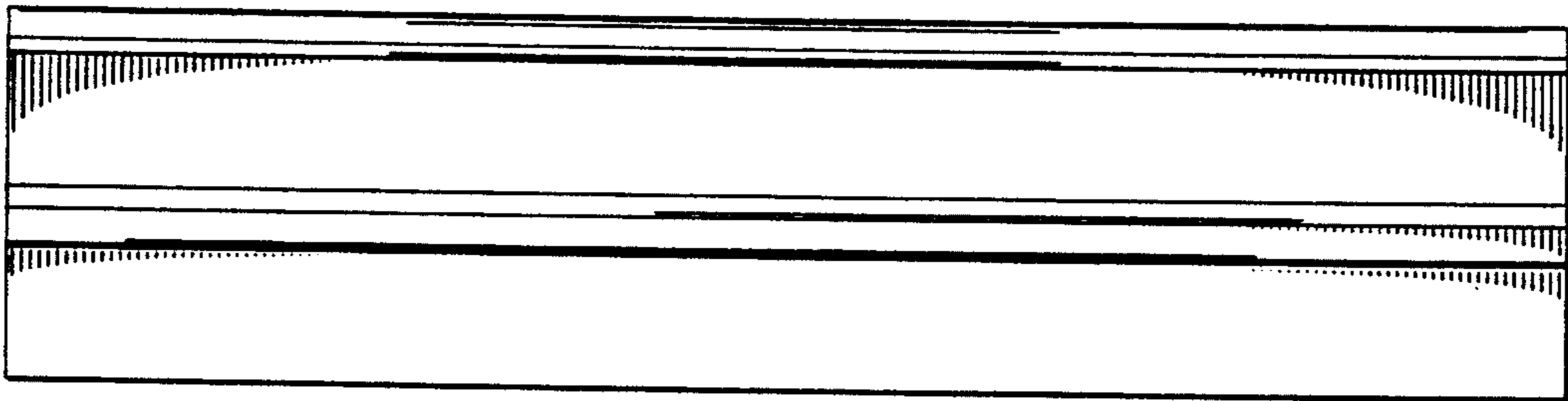

FIG. 4

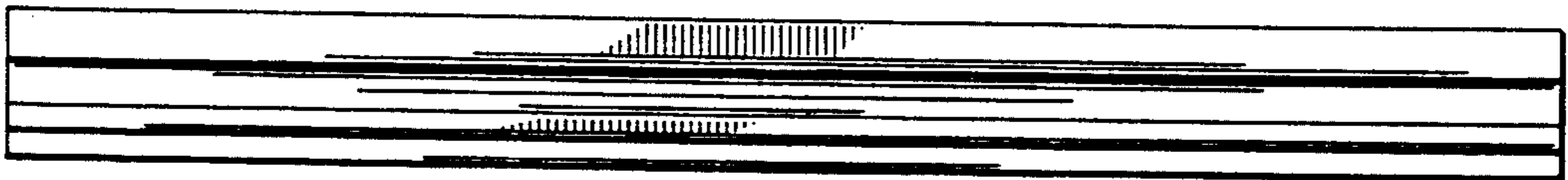

FIG. 5

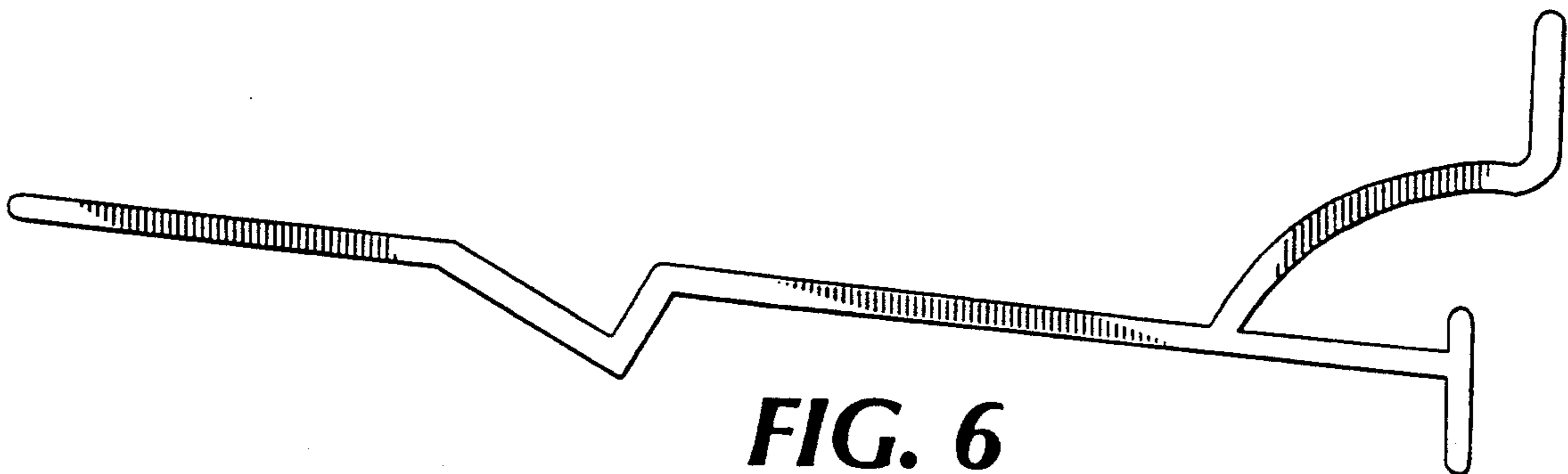

FIG. 6