



US00D344034S

United States Patent [19]
Gottlieb

[11] **Patent Number: Des. 344,034**

[45] **Date of Patent: ** Feb. 8, 1994**

[54] **BACK-UP WARNING SIGNAL FOR VEHICLES**

[75] **Inventor: Mark Gottlieb, Annandale, Va.**

[73] **Assignee: Design Tech International, Inc., Springfield, Va.**

[**] **Term: 14 Years**

[21] **Appl. No.: 4,742**

[22] **Filed: Feb. 12, 1993**

[52] **U.S. Cl. D10/116**

[58] **Field of Search 340/438, 457, 457.2, 340/457.3, 459, 460, 463, 464, 471, 472, 473, 474; D10/104, 106, 116, 121**

[56] **References Cited**

U.S. PATENT DOCUMENTS

D. 238,258	12/1975	Duris	D10/116
2,754,384	7/1956	Atkinson	340/463
2,840,688	6/1958	Scott	340/463
4,903,007	2/1990	Gottlieb	340/463
5,047,747	9/1991	Gottlieb	340/463

Primary Examiner—Wallace R. Burke

Assistant Examiner—Marcus Jackson

[57] **CLAIM**

The ornamental design for a back-up warning signal for vehicles, as shown and described.

DESCRIPTION

FIG. 1 is an orthogonal view of the invention;
FIG. 2 is a front view of the invention;
FIG. 3 is a rear view of the invention;
FIG. 4 is a left view of the invention;
FIG. 5 is a top view of the invention; and,
FIG. 6 is a bottom view of the invention.

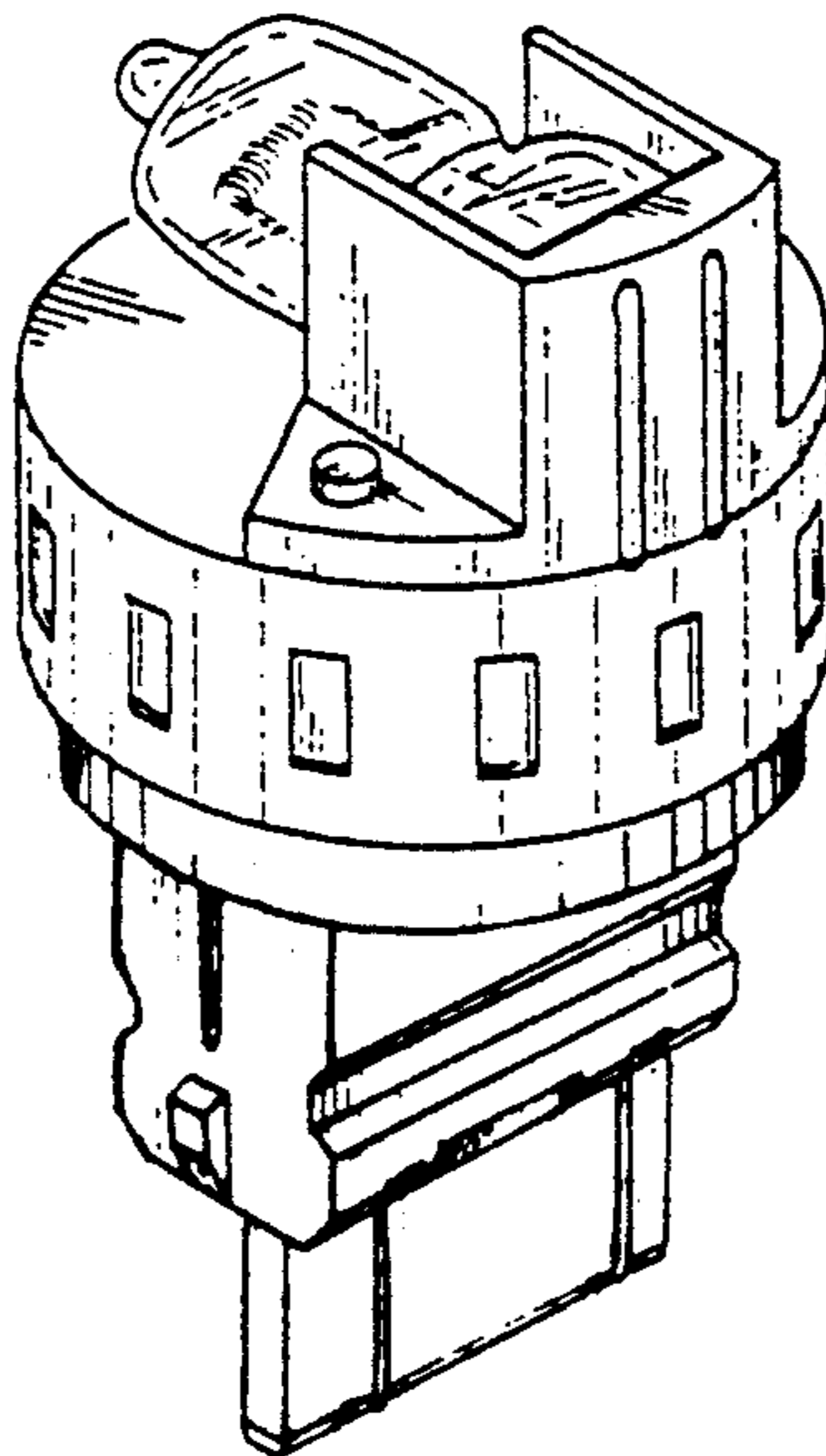

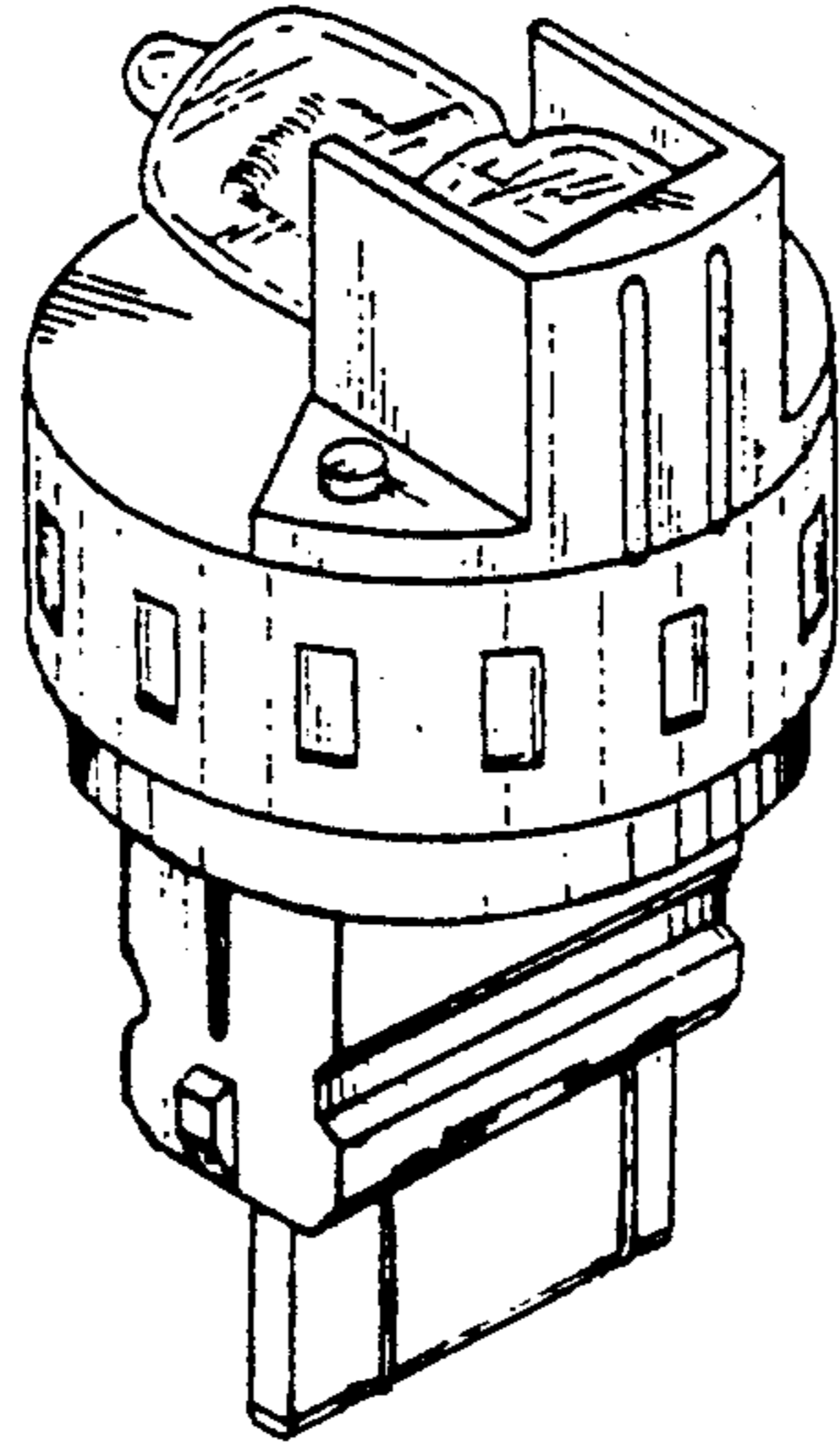

FIG. 1

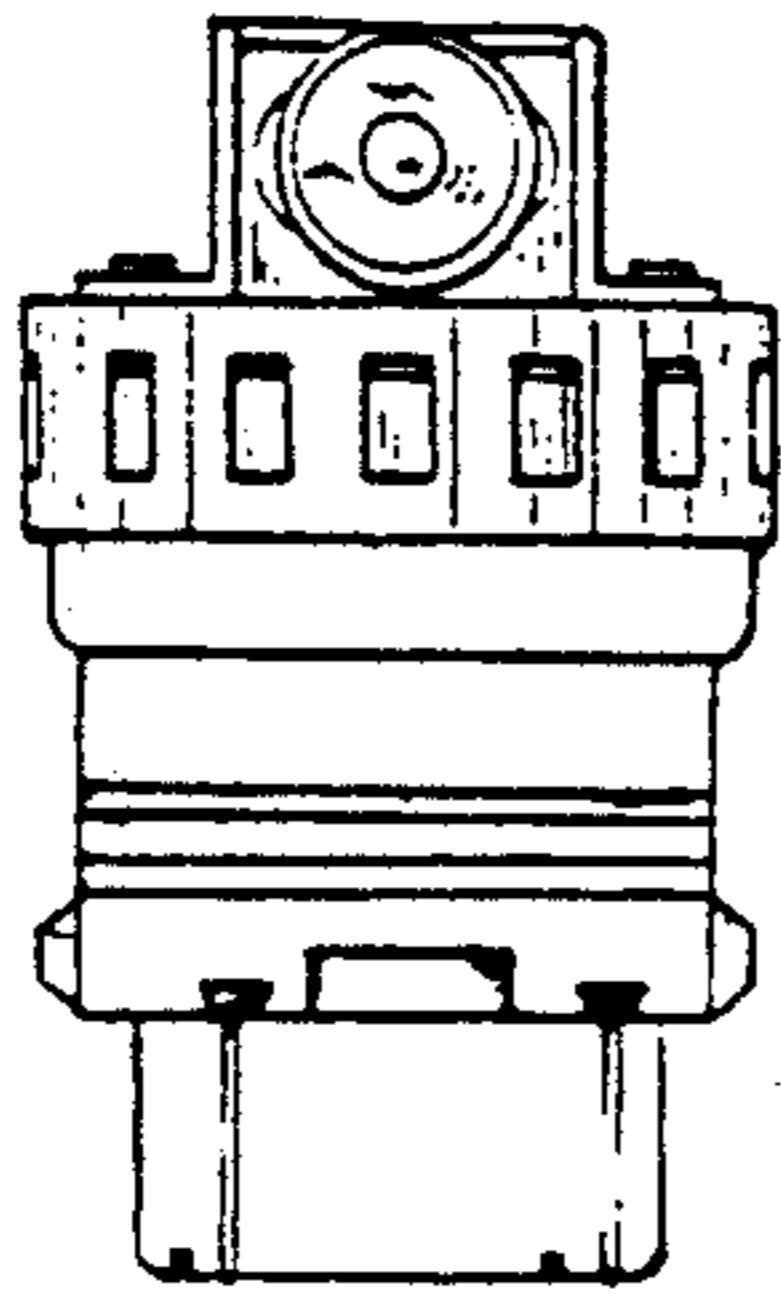

FIG. 2

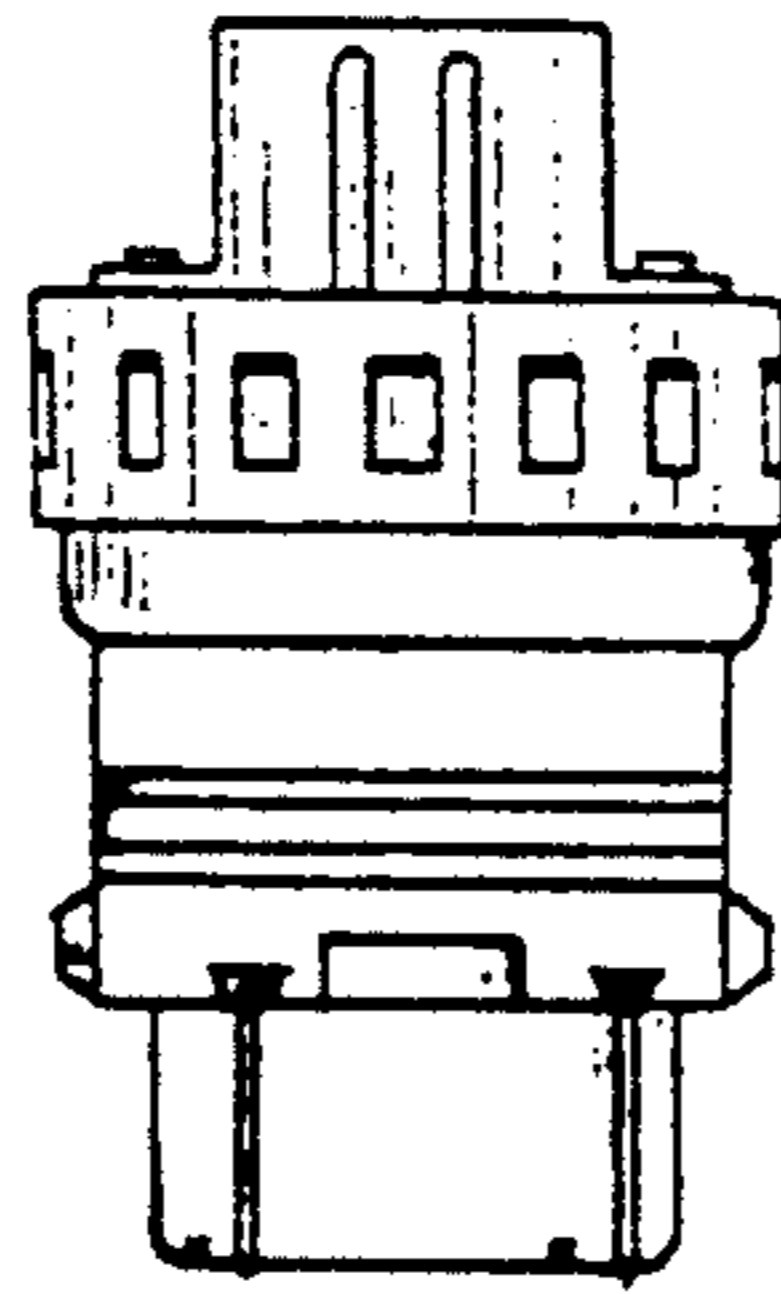

FIG. 3

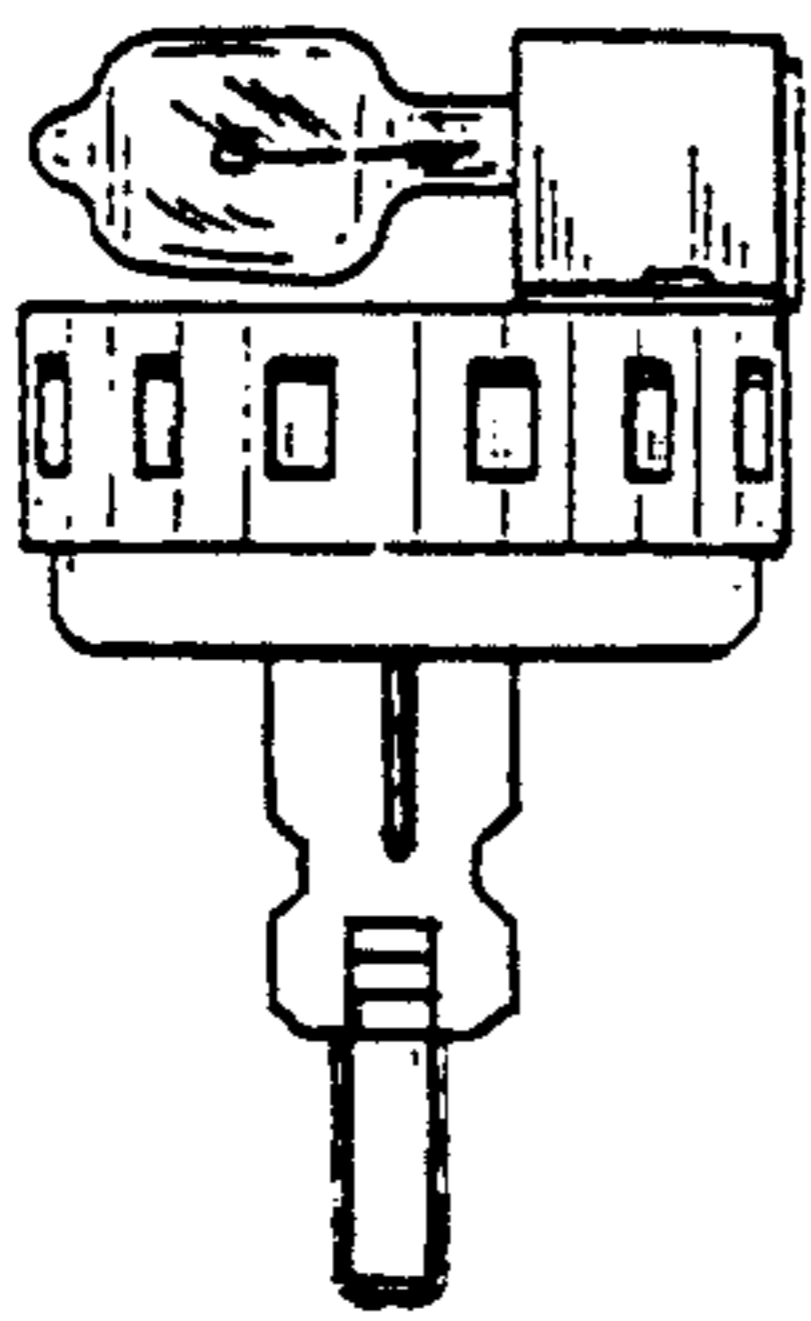

FIG. 4

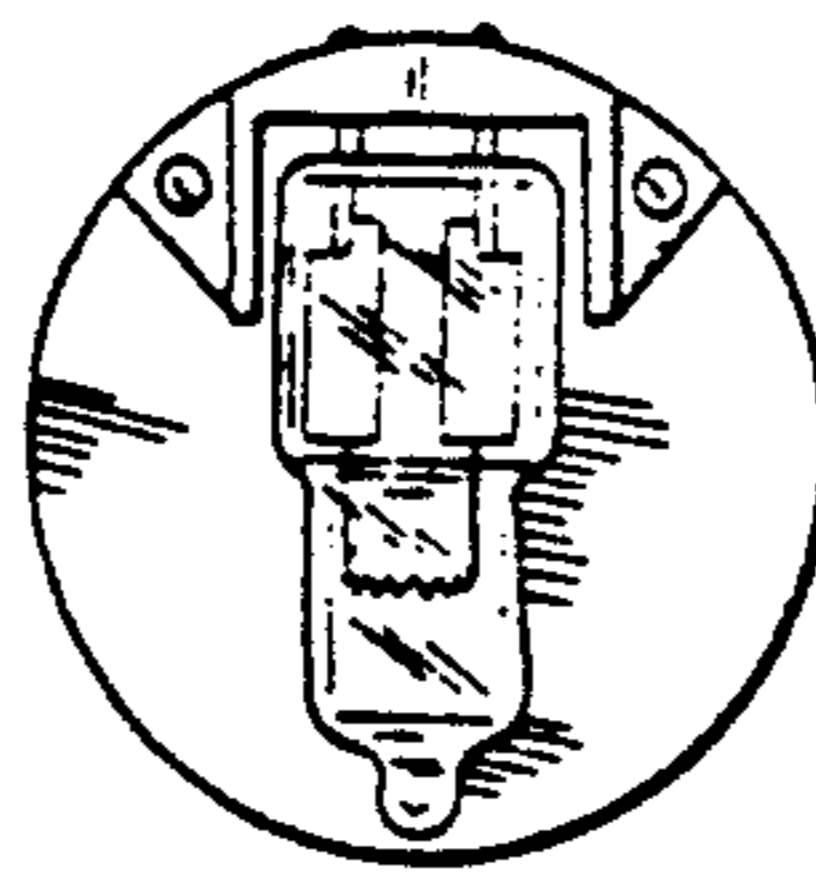

FIG. 5

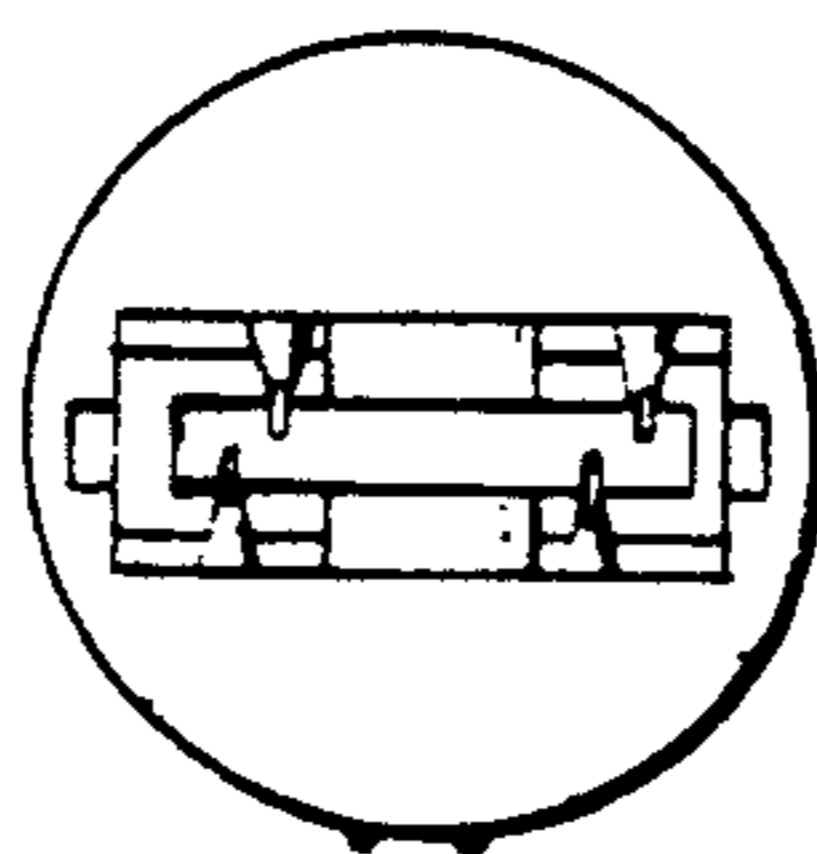

FIG. 6