



US00D344000S

United States Patent [19]

Shibata et al.

[11] Patent Number: **Des. 344,000**

[45] Date of Patent: **** Feb. 8, 1994**

[54] **ELECTRIC SCREWDRIVER**

D. 330,152 10/1992 Ogawa et al. D8/68

[75] Inventors: **Yoshinori Shibata, Anjo; Masaki Kondo, Hazu, both of Japan**

[73] Assignee: **Makita Corporation, Anjo, Japan**

[**] Term: **14 Years**

[21] Appl. No.: **4,328**

[22] Filed: **Feb. 2, 1993**

[30] **Foreign Application Priority Data**

Sep. 29, 1992 [JP] Japan 4-28567

[52] U.S. Cl. **D8/68**

[58] **Field of Search** D8/61, 68; 81/54, 57, 81/57.11, 57.13, 57.14; 173/170; 408/124, 125

[56] **References Cited**

U.S. PATENT DOCUMENTS

D. 302,786 8/1989 Fushiya et al. D8/68

D. 304,287 10/1989 Zurwelle D8/68

D. 319,763 9/1991 Reiferscheid D8/68

OTHER PUBLICATIONS

Makita Corp. Catalog (1991) "Industrial Quality Power Tools" pp. 47 #'s, 6404, 6510LVR, 6402, 6000LR and p. 51 #'s 6800DBV, 6801DBV, 6820V, 6802BV, 6805BV.

Primary Examiner—Alan P. Douglas

Assistant Examiner—J. H. Musgrove

Attorney, Agent, or Firm—Lahive & Cockfield

[57] CLAIM

The ornamental design for a electric screwdriver, as shown and described.

DESCRIPTION

FIG. 1 is a perspective view from the front of a electric screwdriver showing my new design; FIG. 2 is a front elevational view thereof; FIG. 3 is a rear elevational view thereof; FIG. 4 is a left hand elevational view thereof; FIG. 5 is a right hand elevational view thereof; FIG. 6 is a top plan view thereof; and, FIG. 7 is a bottom plan view thereof.

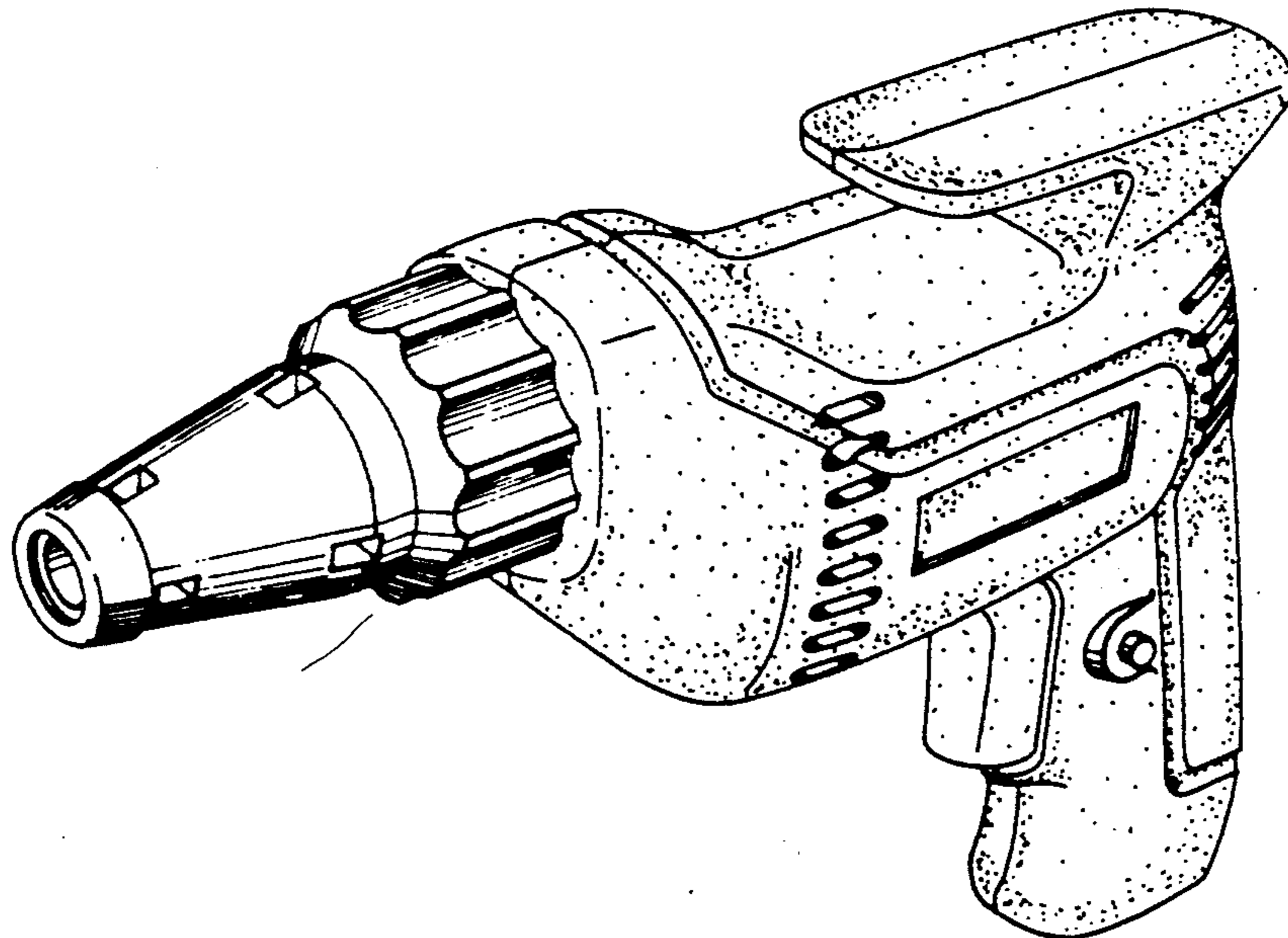

FIG. 1

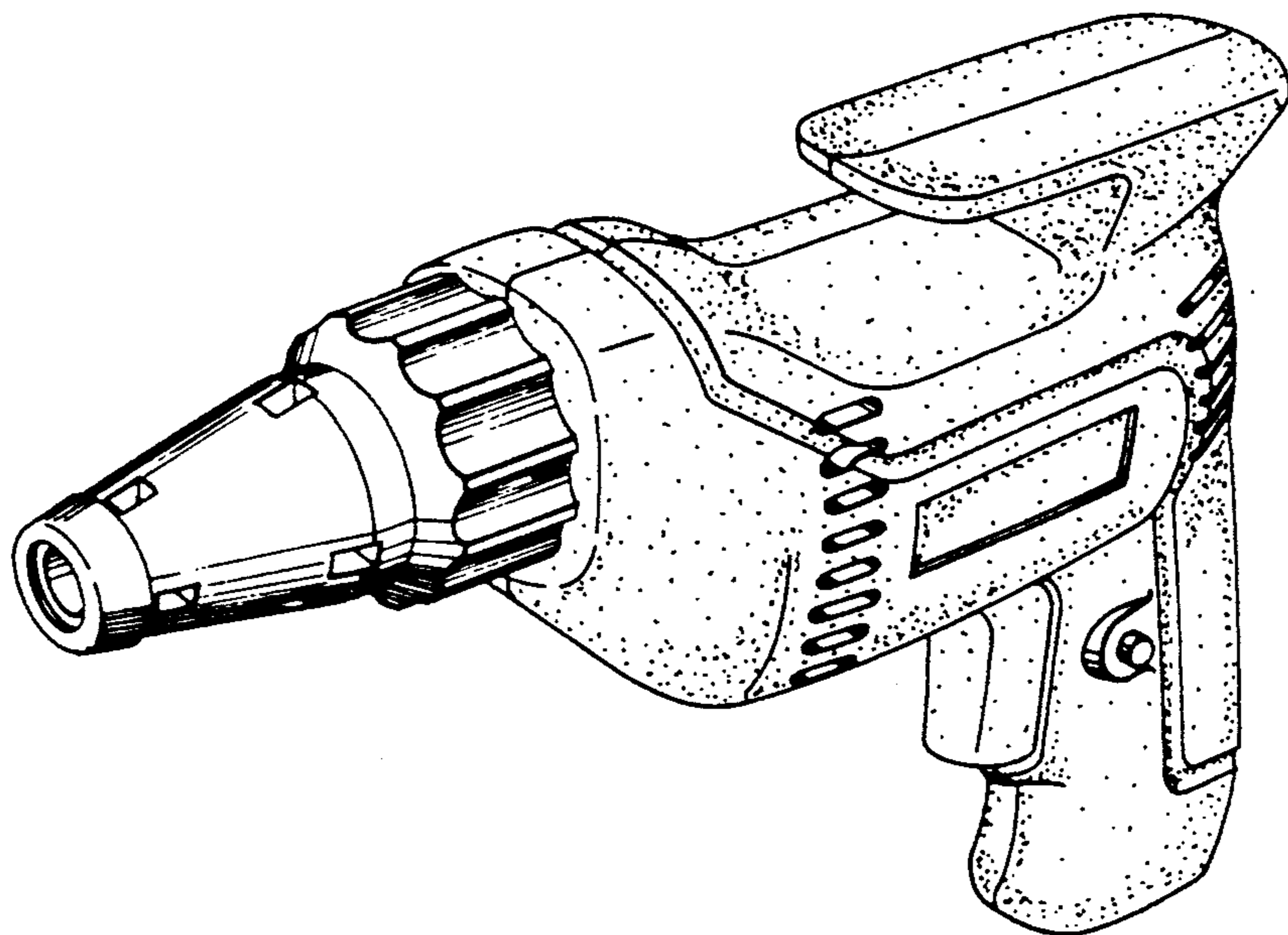

FIG. 2

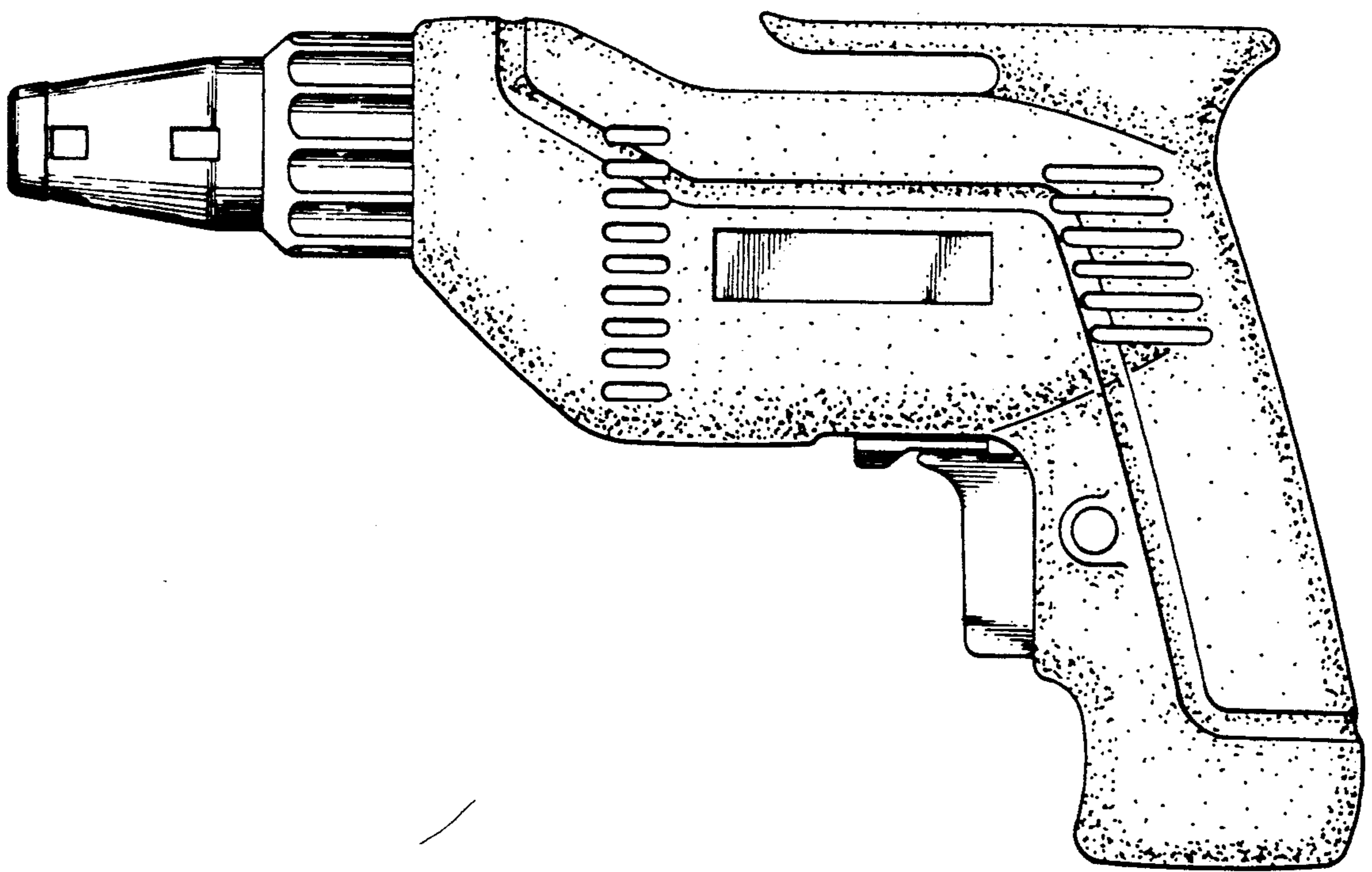

FIG. 3

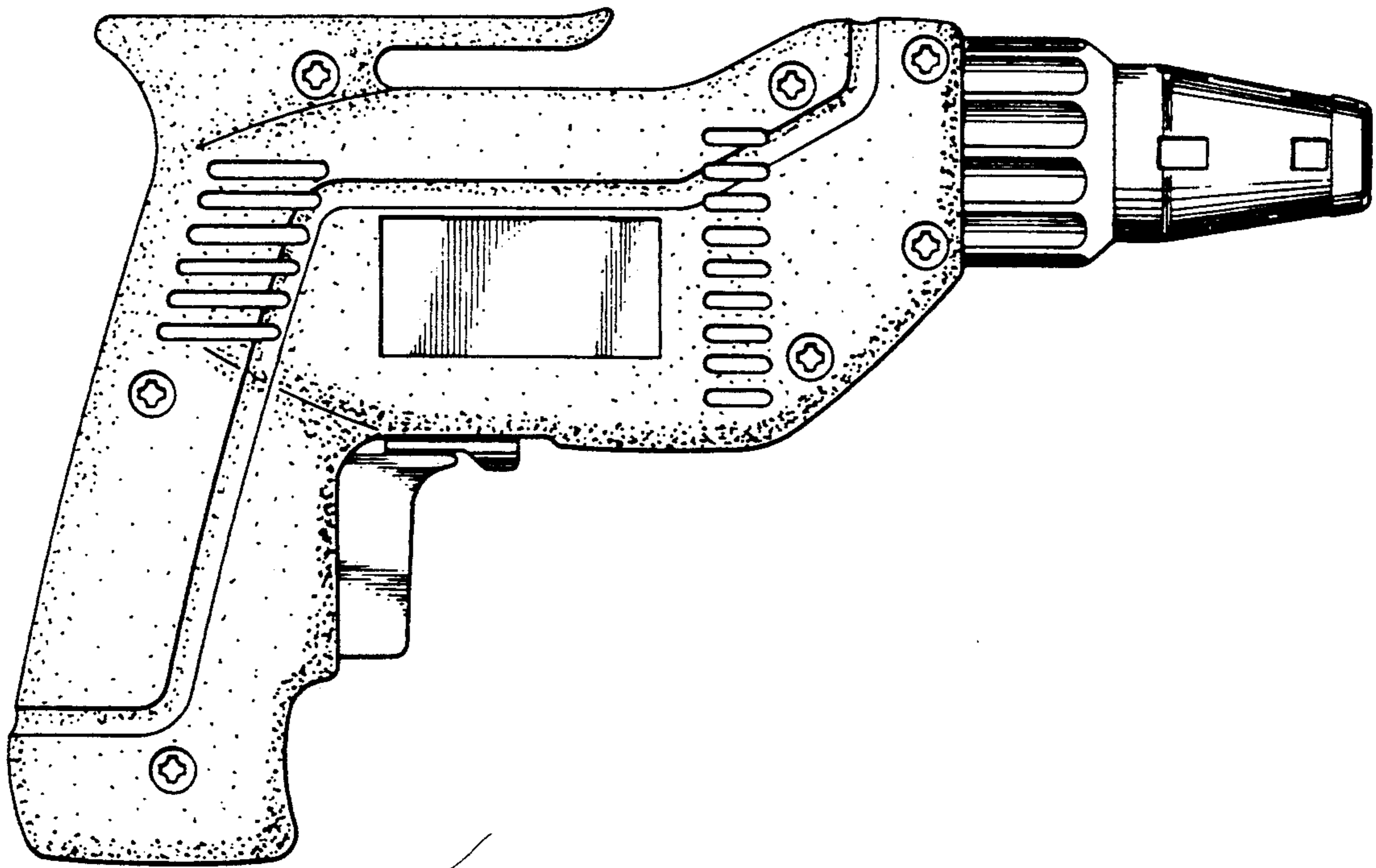

FIG. 4

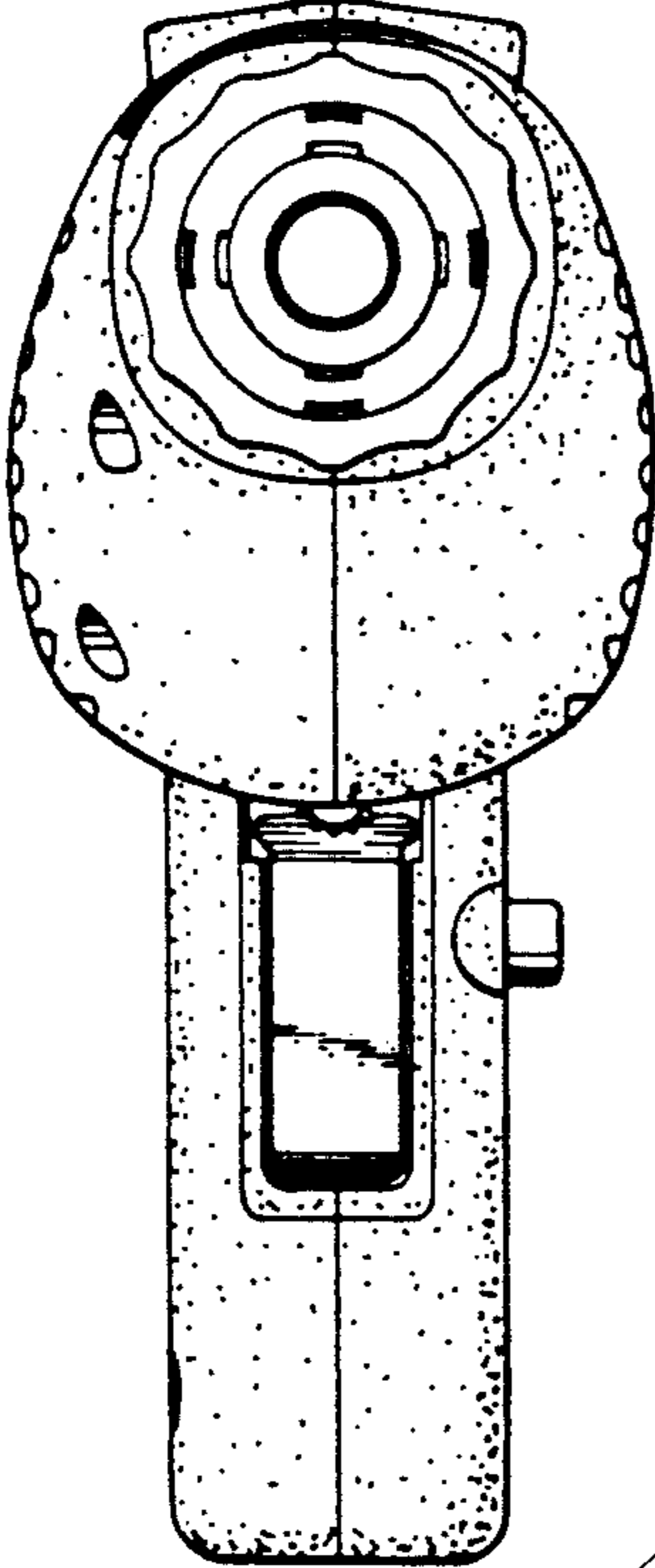

FIG. 5

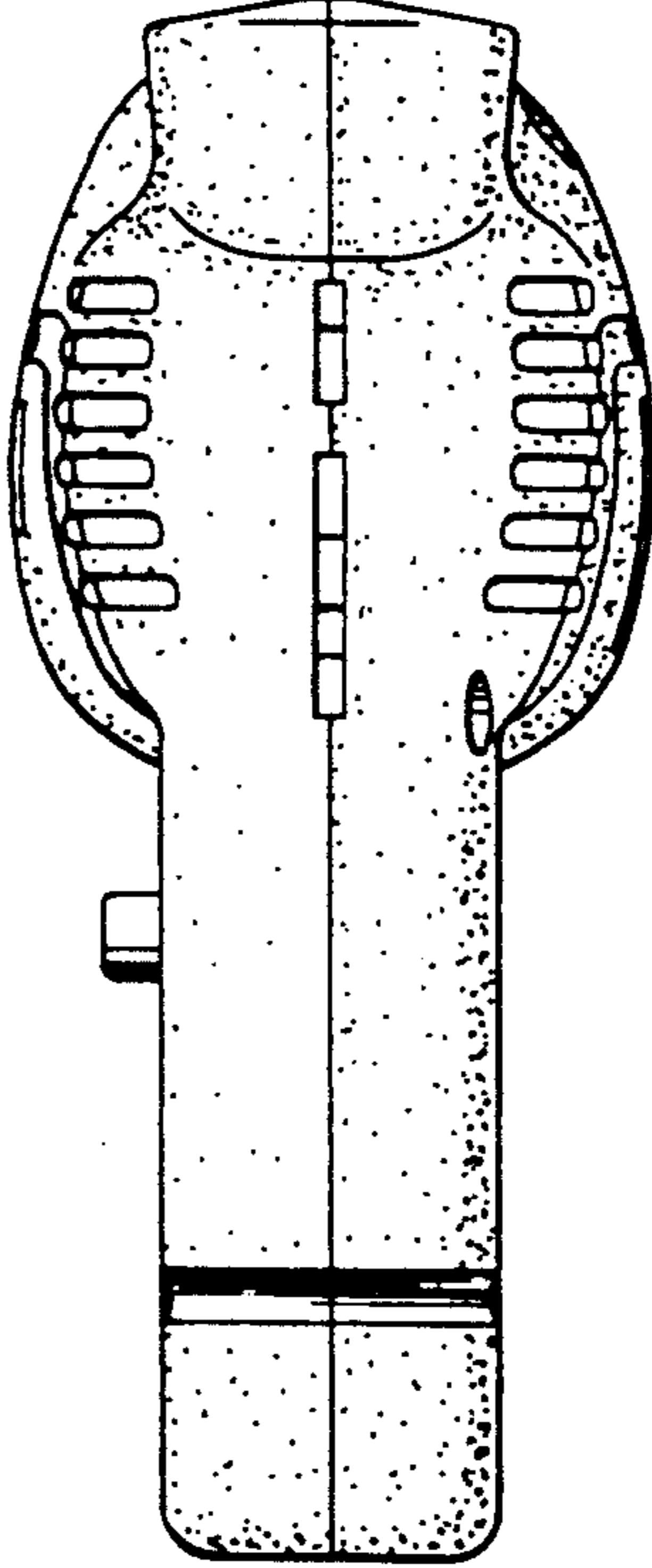

FIG. 6

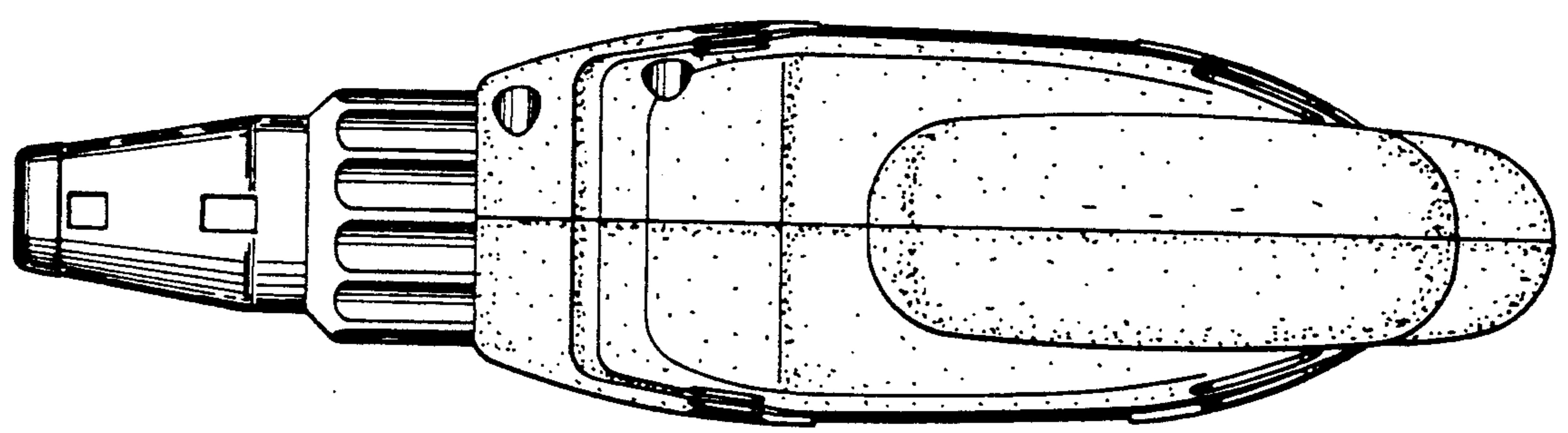

FIG. 7

