



US00D343833S

# United States Patent [19]

Barr et al.

[11] Patent Number: Des. 343,833

[45] Date of Patent: \*\* Feb. 1, 1994

[54] CARTRIDGE FOR VIDEO GAME MACHINE

[75] Inventors: Lance Barr, Redmond, Wash.; Mitsuru Hitomi, Kyoto, Japan

[73] Assignee: Nintendo Co., Ltd., Japan

[\*\*] Term: 14 Years

[21] Appl. No.: 757,431

[22] Filed: Sep. 10, 1991

[30] Foreign Application Priority Data

Mar. 26, 1991 [JP] Japan ..... 3-8433

[52] U.S. Cl. .... D14/121

[58] Field of Search ..... 242/55, 19 A, 197-200; 273/DIG. 28, 85 G; D14/114, 120-122, 299

[56] References Cited

### U.S. PATENT DOCUMENTS

- D. 252,753 8/1979 Thompson et al. .... D14/114
- D. 260,515 9/1981 Welch et al. .... D14/121 X
- D. 260,881 9/1981 McKinsey et al. .... D14/114
- D. 277,189 1/1985 Shibata ..... D14/114
- D. 285,307 8/1986 Clarke ..... D14/121 X
- D. 292,399 10/1987 Yukawa ..... D14/11
- D. 294,020 2/1988 Yukawa ..... D14/11
- D. 308,197 5/1990 Inoue ..... D14/114
- D. 312,081 11/1990 Yukawa ..... D14/121

- D. 317,913 7/1991 Tnoe ..... D14/114
- D. 320,203 9/1991 Ashida ..... D14/121
- D. 321,429 11/1991 Kojo ..... D3/35

Primary Examiner—Theodore M. Shooman  
Attorney, Agent, or Firm—Nixon & Vanderhye

### [57] CLAIM

The ornamental design for a cartridge for video game machine, as shown and described.

### DESCRIPTION

FIG. 1 is a front, top and right side perspective view of a cartridge for a video game machine showing our new design;

FIG. 2 is a rear, bottom and left perspective view thereof;

FIG. 3 is a front elevational view thereof;

FIG. 4 is a rear elevational view thereof;

FIG. 5 is a top plan view thereof;

FIG. 6 is a bottom plan view thereof;

FIG. 7 is a right side elevational view thereof, a left side being a mirror image;

FIG. 8 is a front, top and right side perspective view of a second embodiment of the cartridge for a video game machine illustrated in FIG. 1; and,

FIG. 9 is a rear, bottom and left side perspective view thereof.

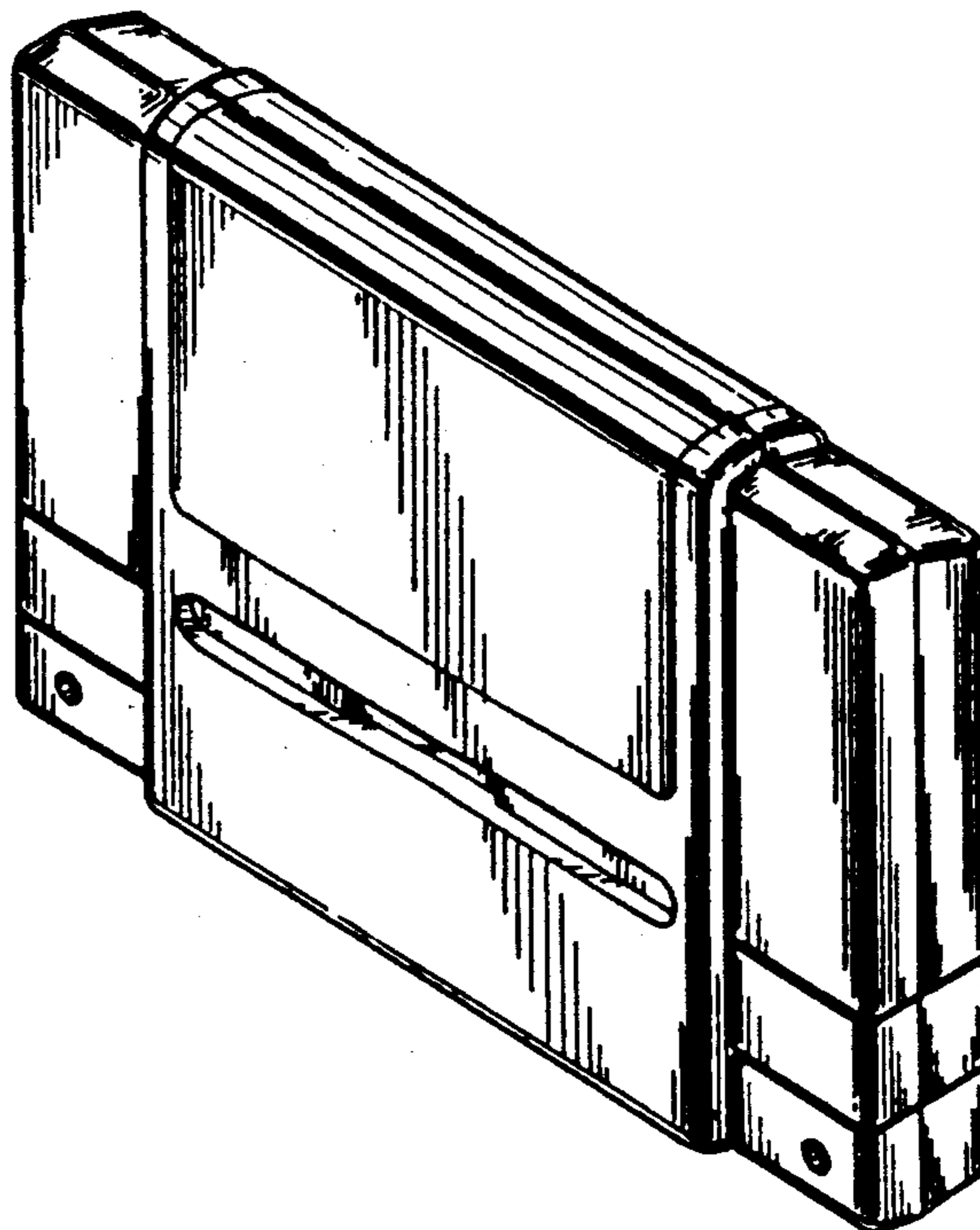
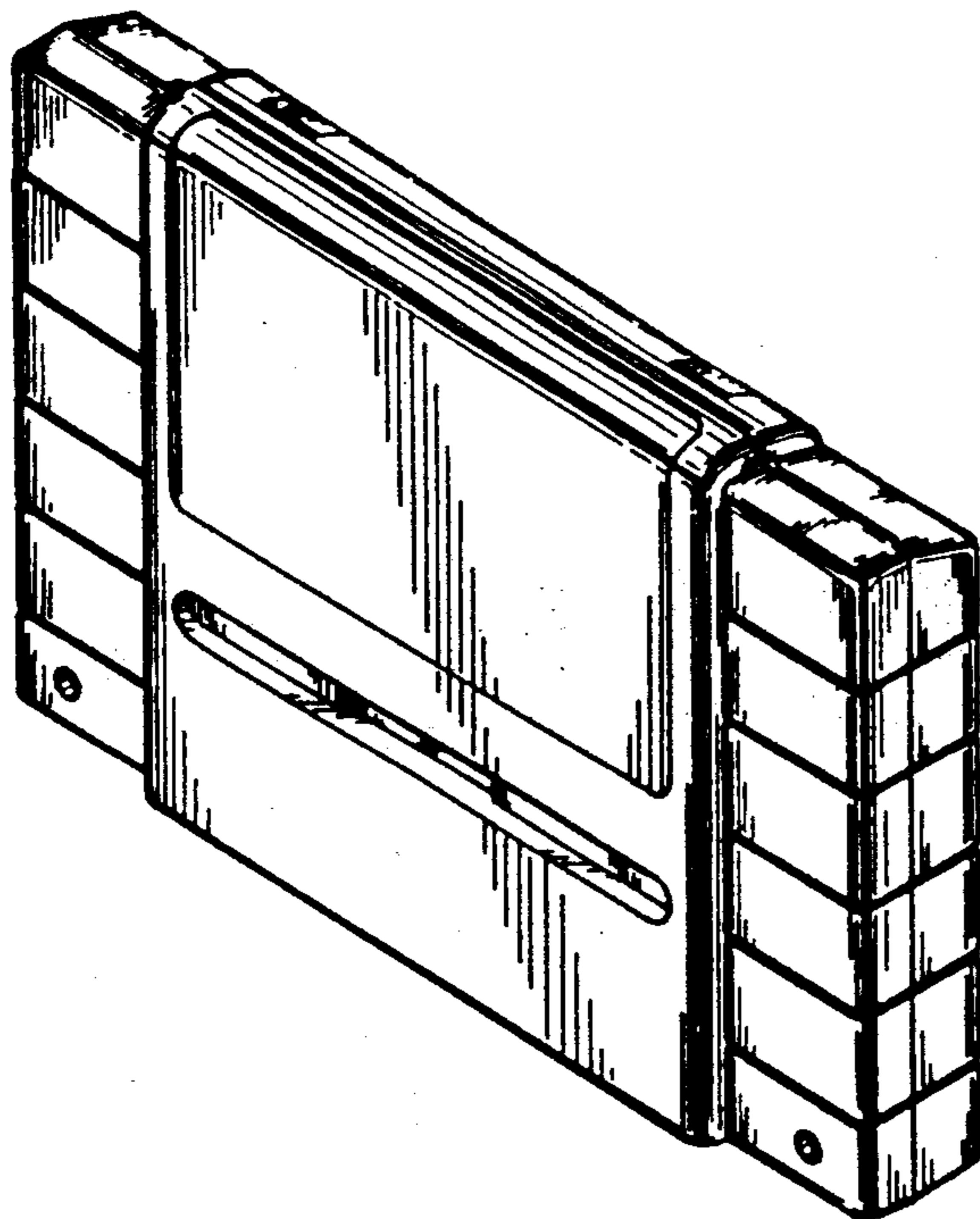

FIG. 1

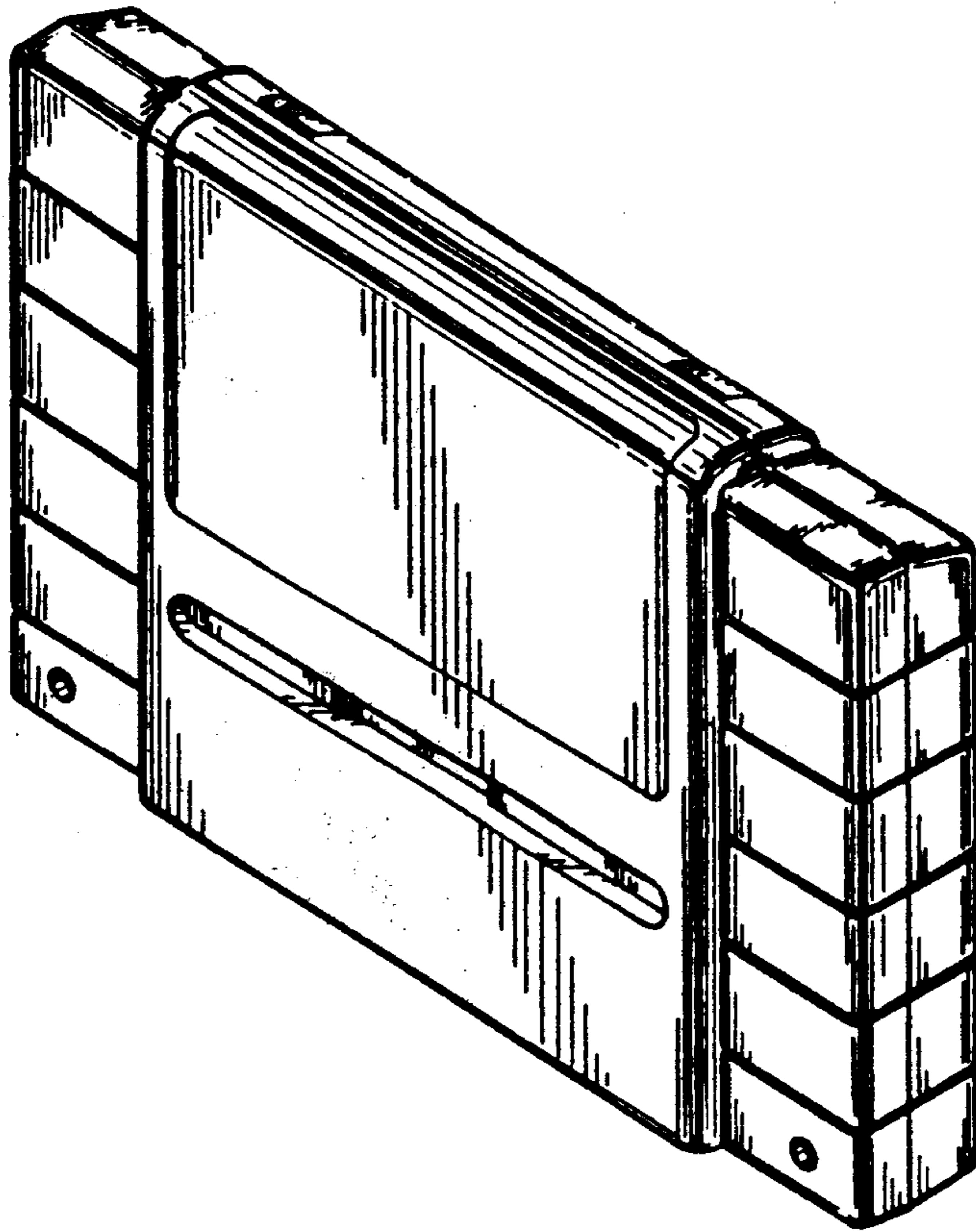

FIG. 2

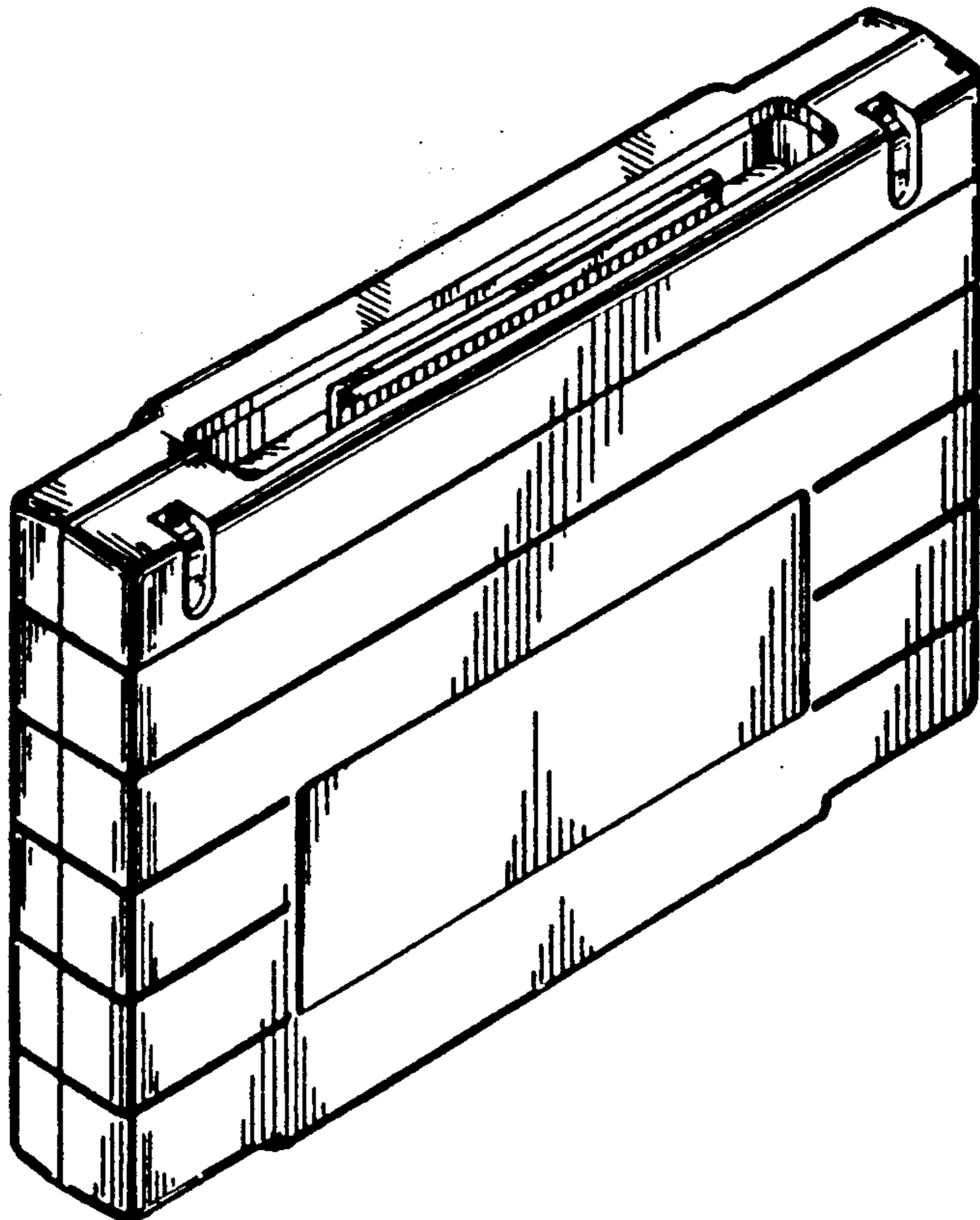

FIG. 3

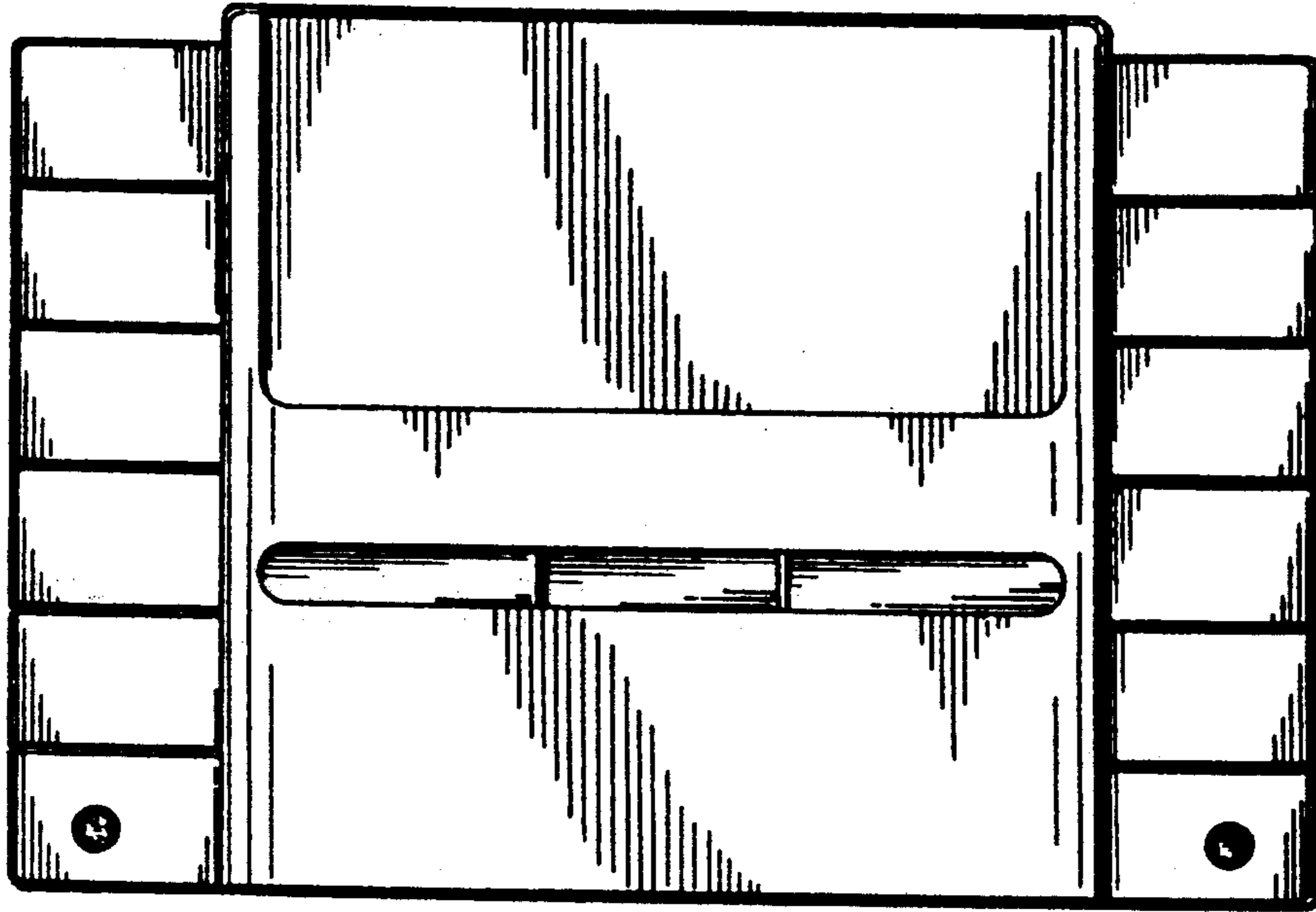

FIG. 4

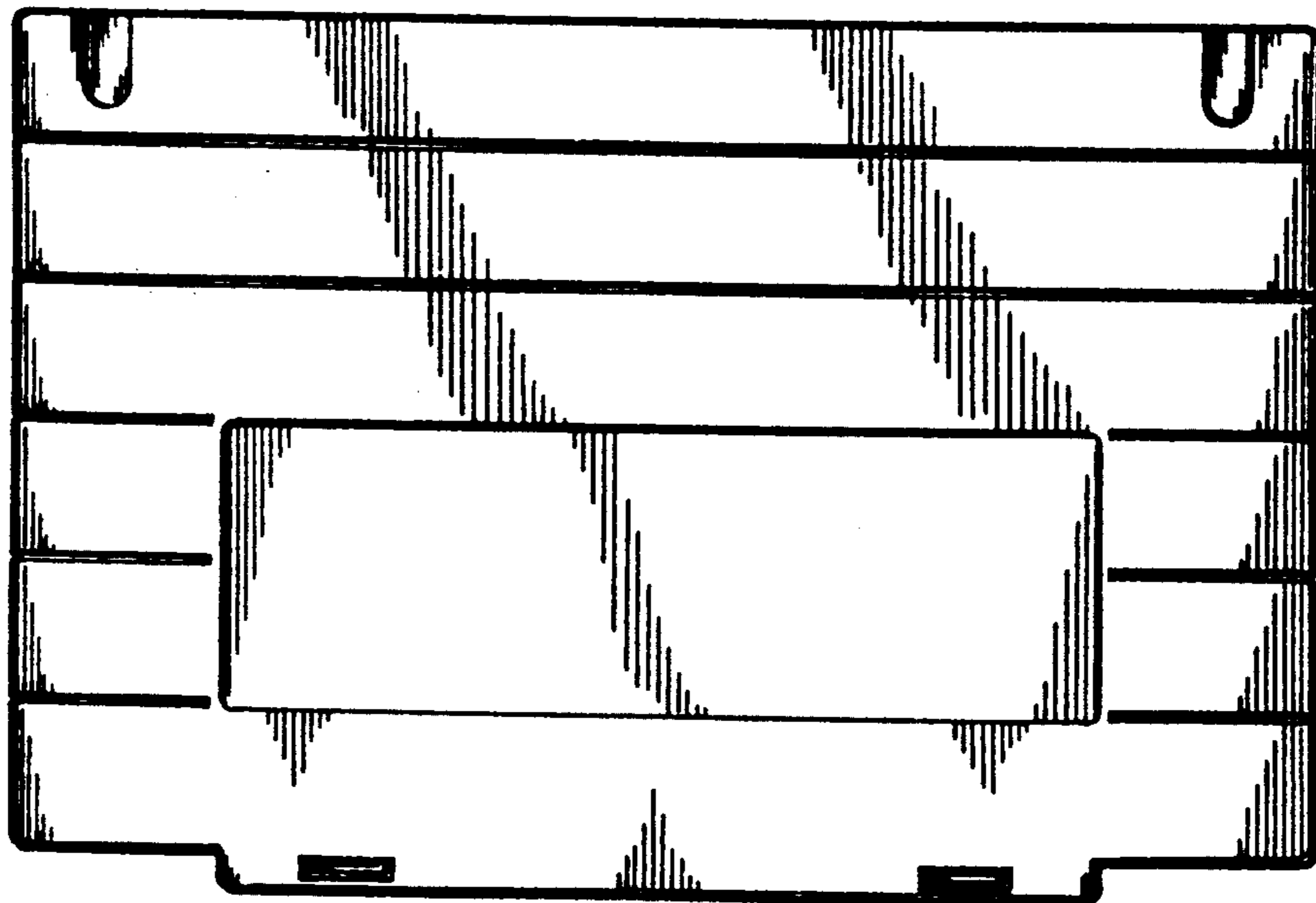

FIG. 5

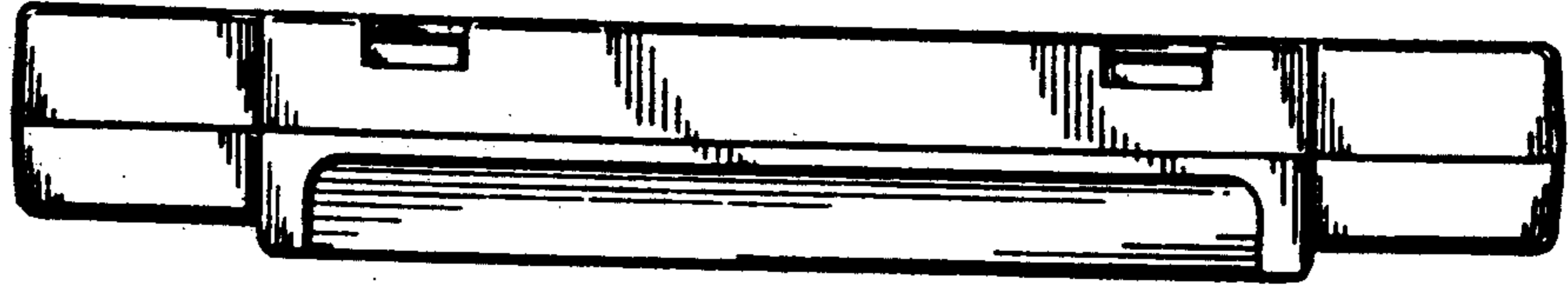

FIG. 6

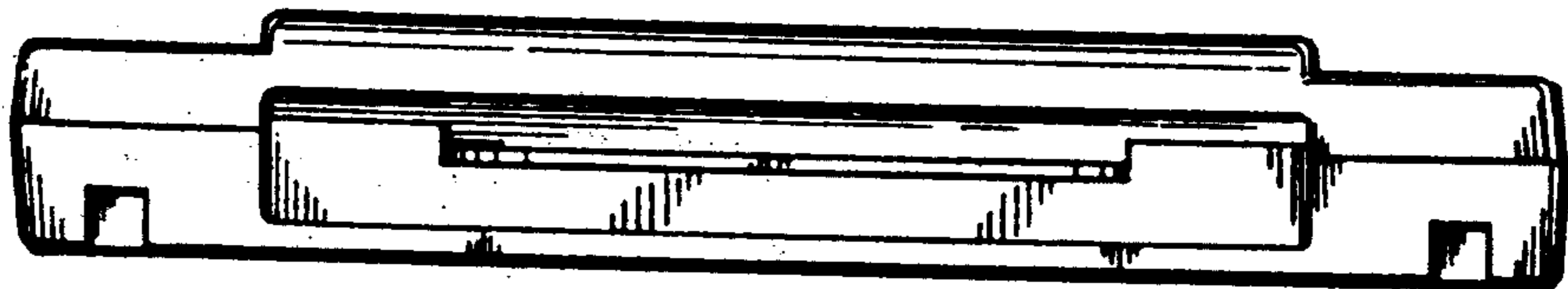

FIG. 7

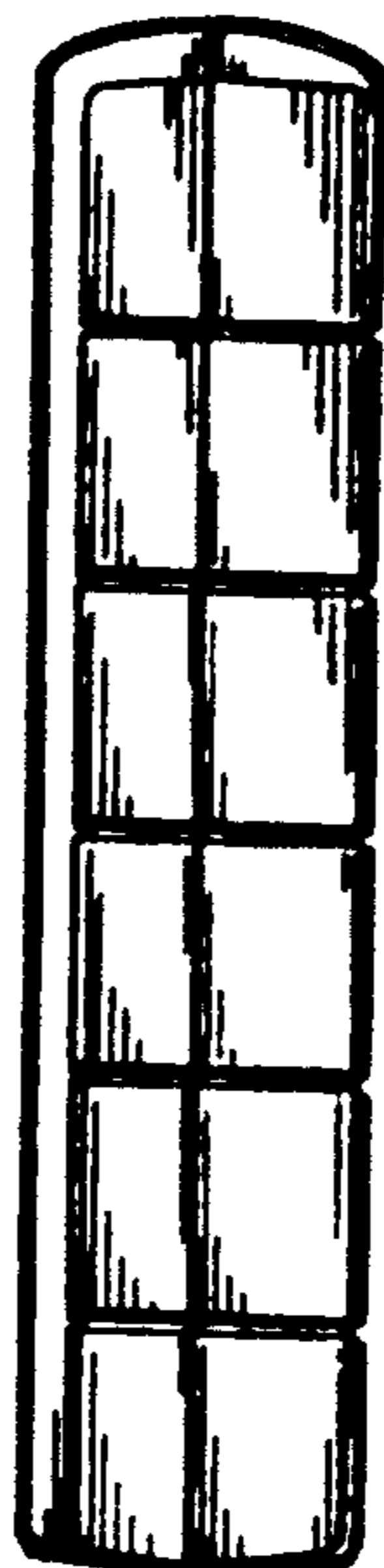



FIG. 8

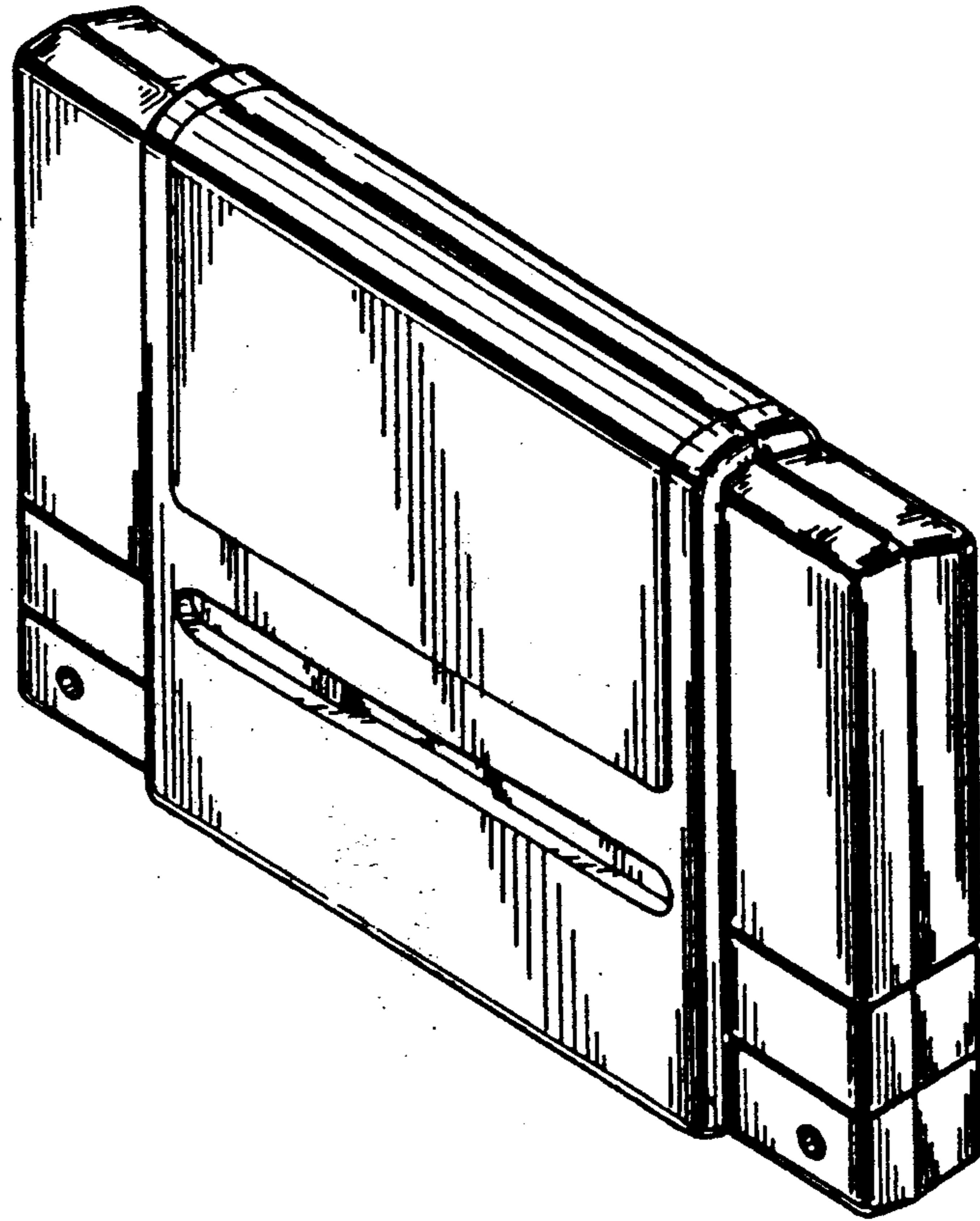

FIG. 9

