



US00D343816S

# United States Patent [19]

De Silva

[11] Patent Number: Des. 343,816

[45] Date of Patent: \*\* Feb. 1, 1994

[54] VARIABLE BICYCLE BALL CARRIER

[76] Inventor: Glenn De Silva, 10121 Tabor St., #12, Los Angeles, Calif. 90034

[\*\*] Term: 14 Years

[21] Appl. No.: 761

[22] Filed: Oct. 23, 1992

[52] U.S. Cl. .... D12/407; D12/411; D12/114

[58] Field of Search ..... 224/30 R, 30 A, 32 R, 224/32 A, 36; D12/158, 114

[56] **References Cited**

**U.S. PATENT DOCUMENTS**

3,837,545	9/1974	Rogers, Jr. ....	224/32 R
3,938,719	2/1976	Carlton .....	224/32 R
4,069,956	1/1978	Shearer, Sr. et al. ....	224/32 R
4,244,497	1/1981	Lee .....	224/36
4,284,217	8/1981	Johnston et al. ....	224/30 R
4,762,255	8/1988	Dunn .....	224/32 R

Primary Examiner—Wallace R. Burke

Assistant Examiner—Melody Brown

Attorney, Agent, or Firm—Cislo & Thomas

[57] **CLAIM**

The ornamental design for a variable bicycle ball carrier, as shown and described.

**DESCRIPTION**

FIG. 1 is a top perspective view of a variable bicycle ball carrier showing my new design;  
 FIG. 2 is a right side elevational view thereof with the left side elevational view being a mirror image, thereof;  
 FIG. 3 is a top plan view thereof;  
 FIG. 4 is a bottom plan view thereof;  
 FIG. 5 is a rear elevational view thereof;  
 FIG. 6 is a front elevational view thereof;  
 FIG. 7 is a top perspective view of a second embodiment of variable bicycle ball carrier showing my new design;  
 FIG. 8 is a right side elevational view of FIG. 7 with the left side elevational view being a mirror image thereof;  
 FIG. 9 is a top plan view of FIG. 7;  
 FIG. 10 is a bottom plan view of FIG. 7;  
 FIG. 11 is a rear elevational view of FIG. 7; and,  
 FIG. 12 is a front elevational view of FIG. 7.

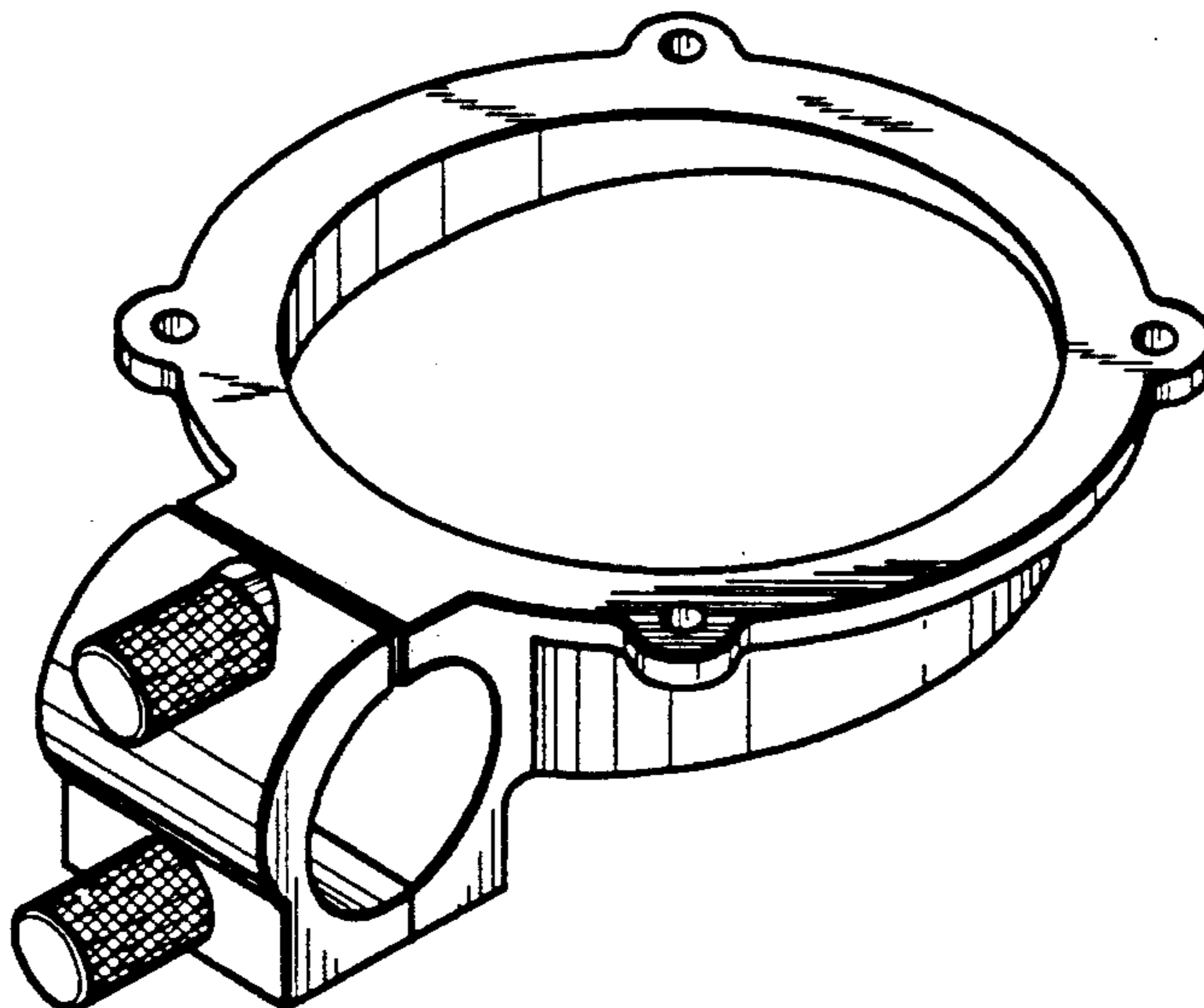

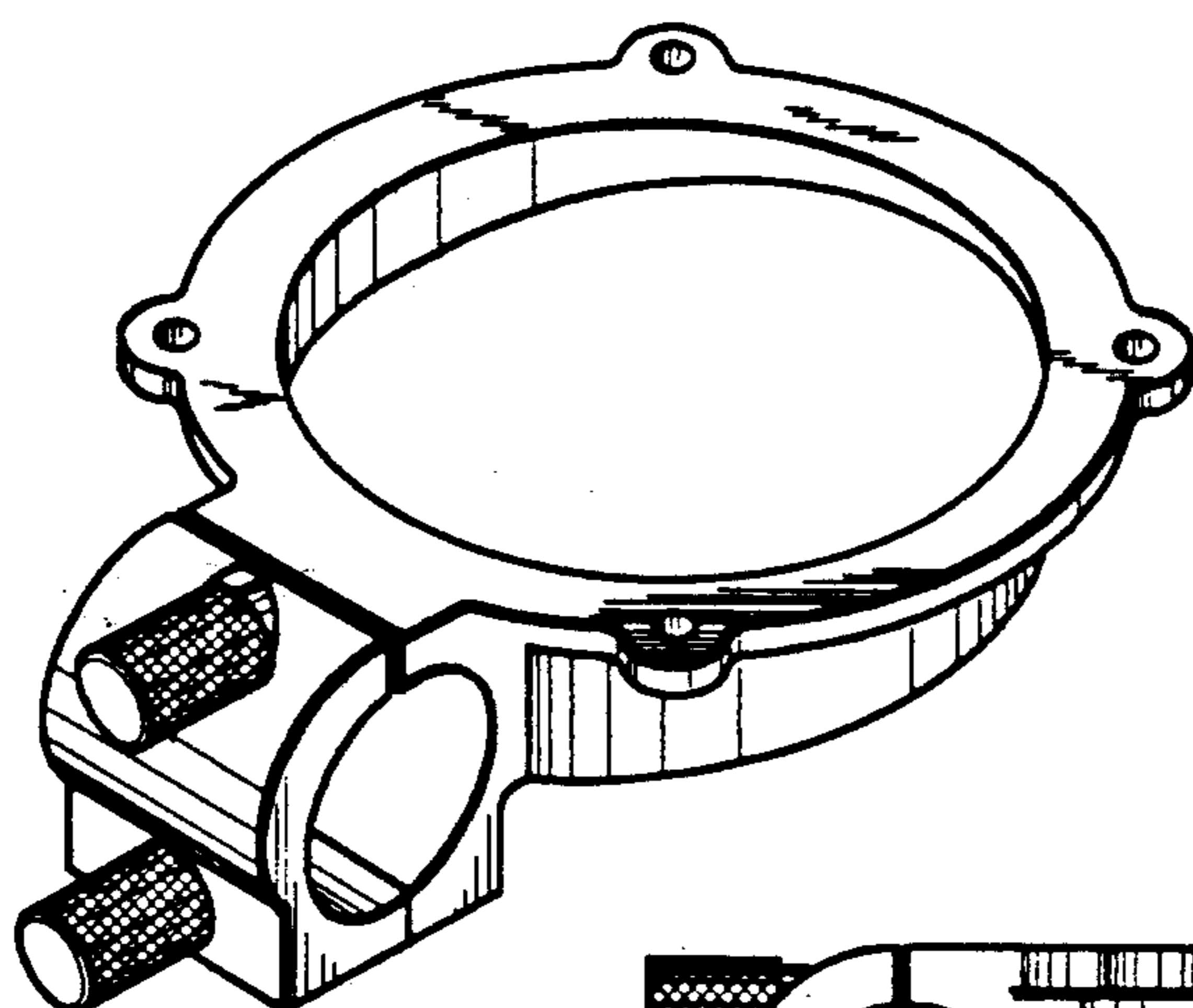

FIG. 1.

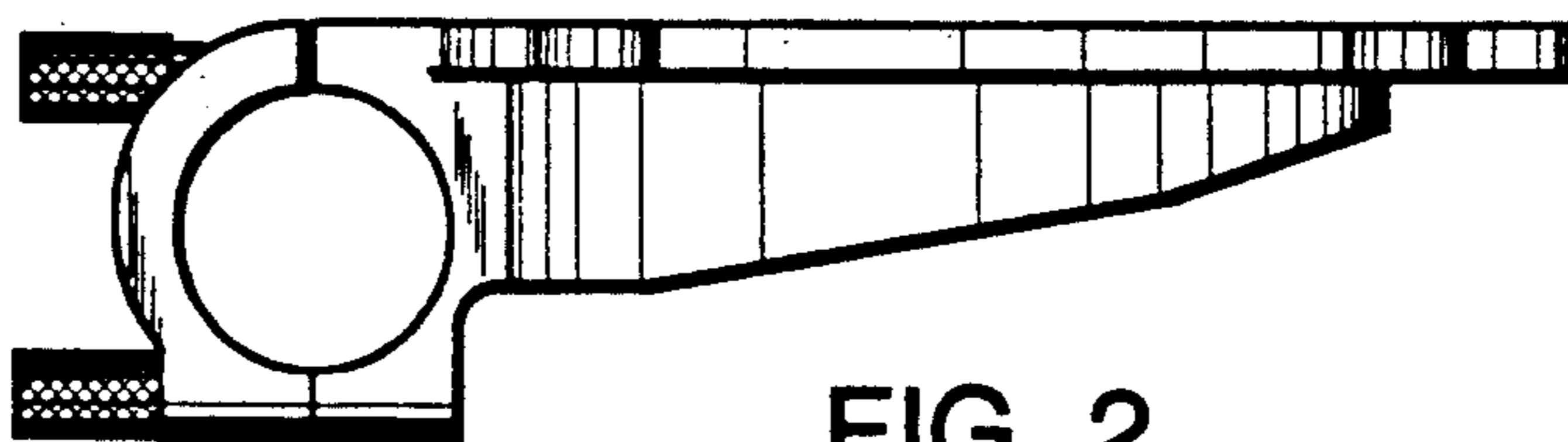

FIG. 2..

FIG. 3.

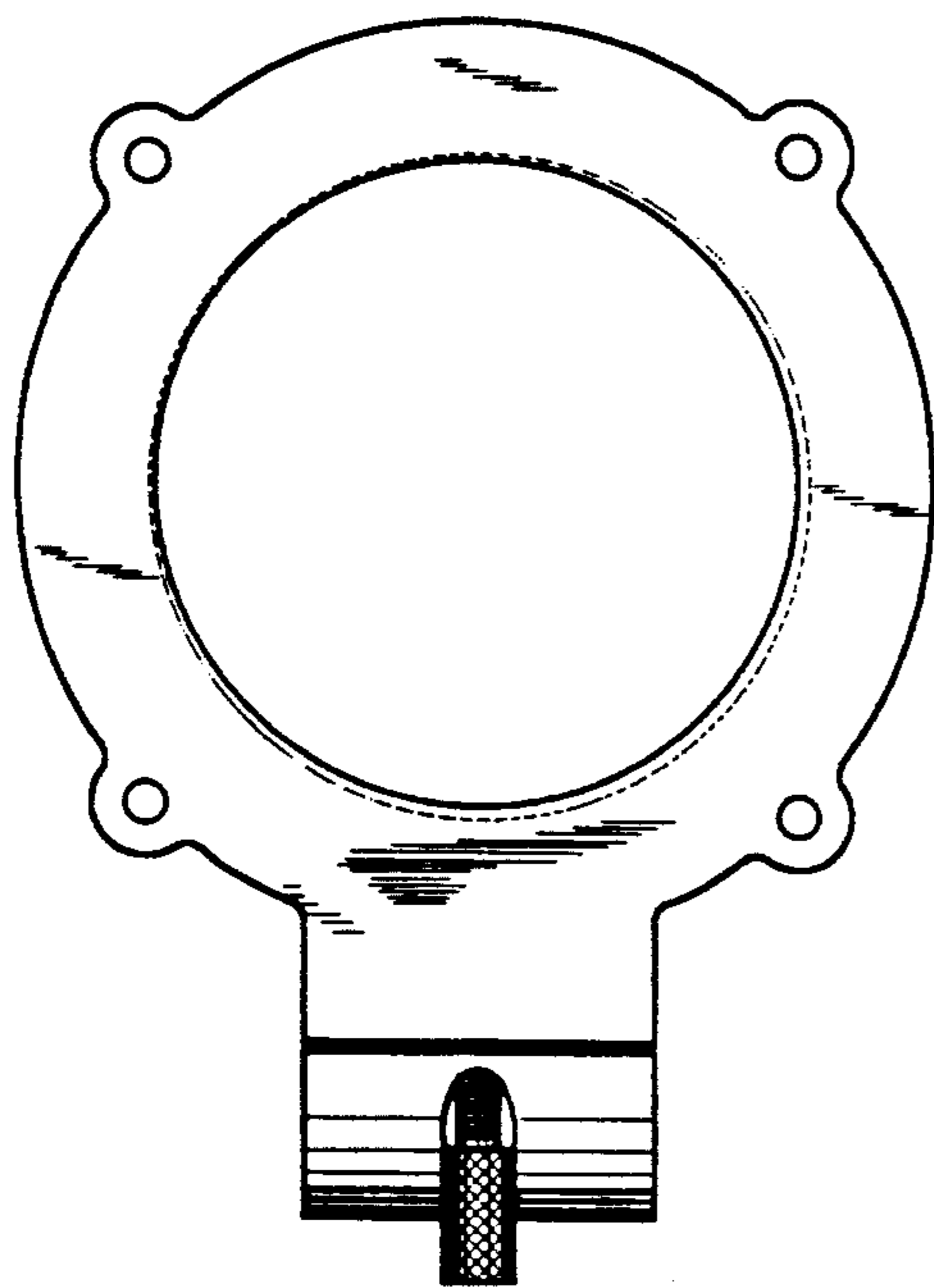

FIG. 5.

FIG. 4.

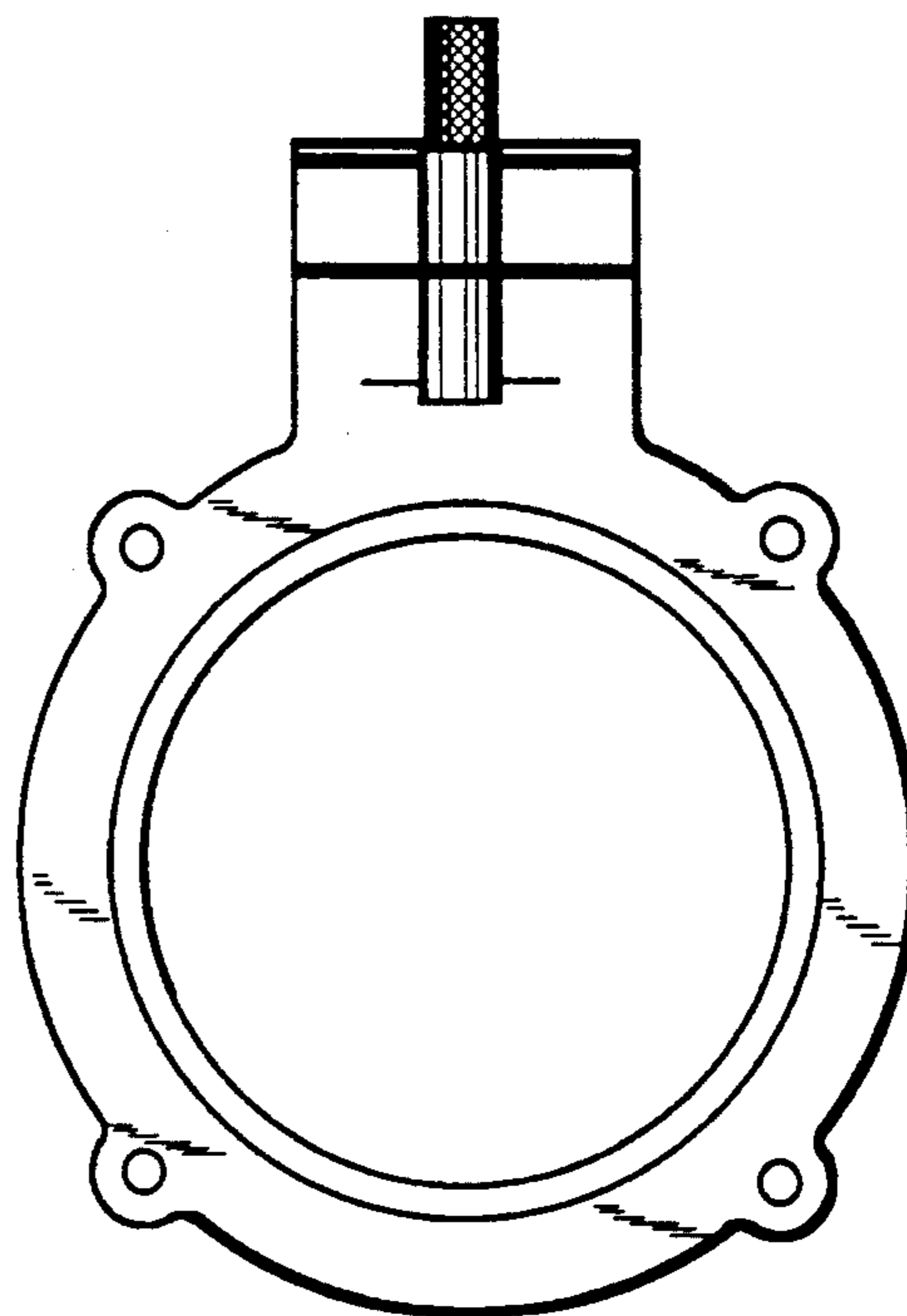
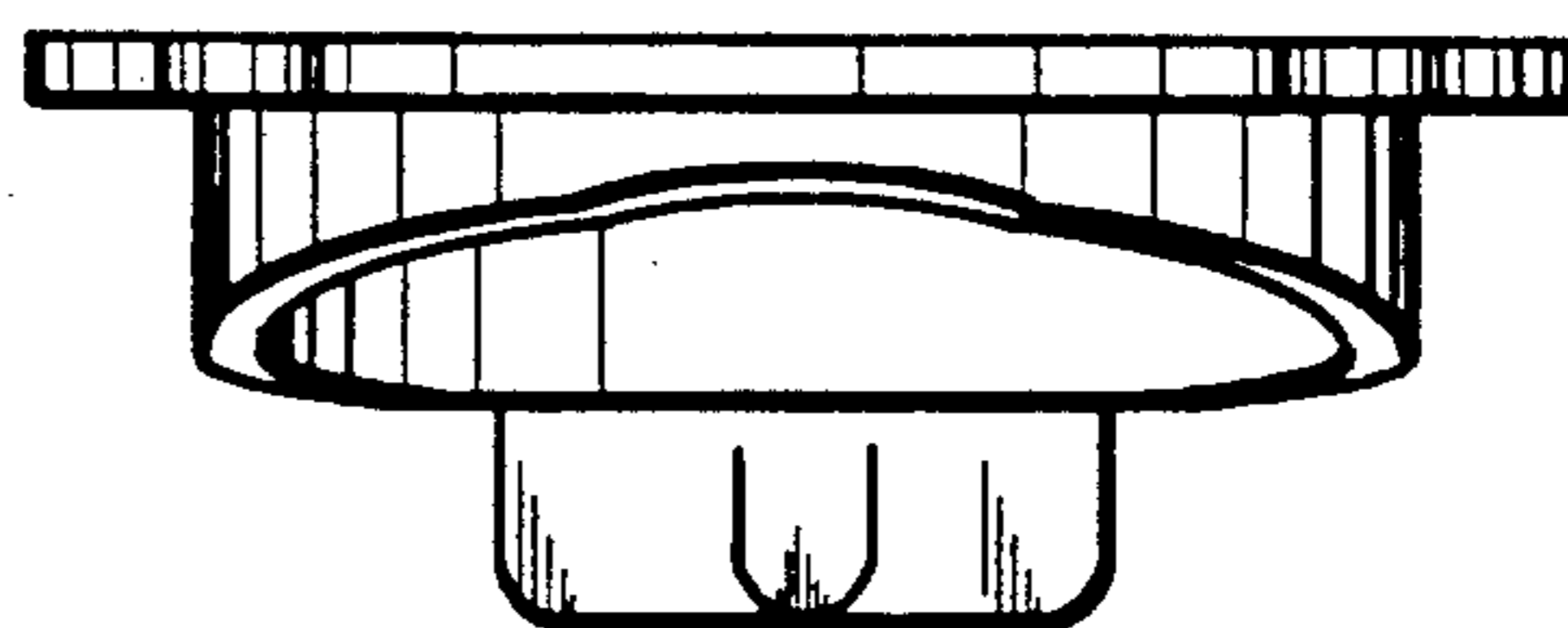
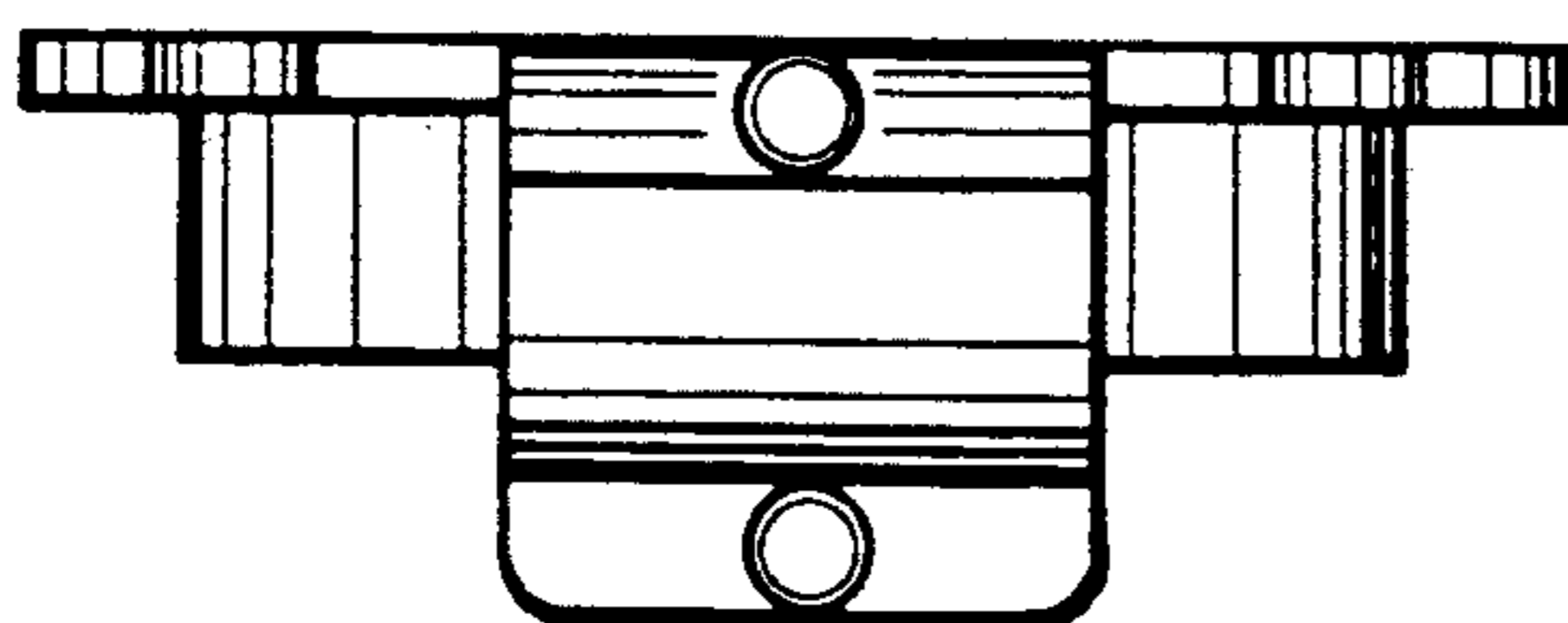

FIG. 6.



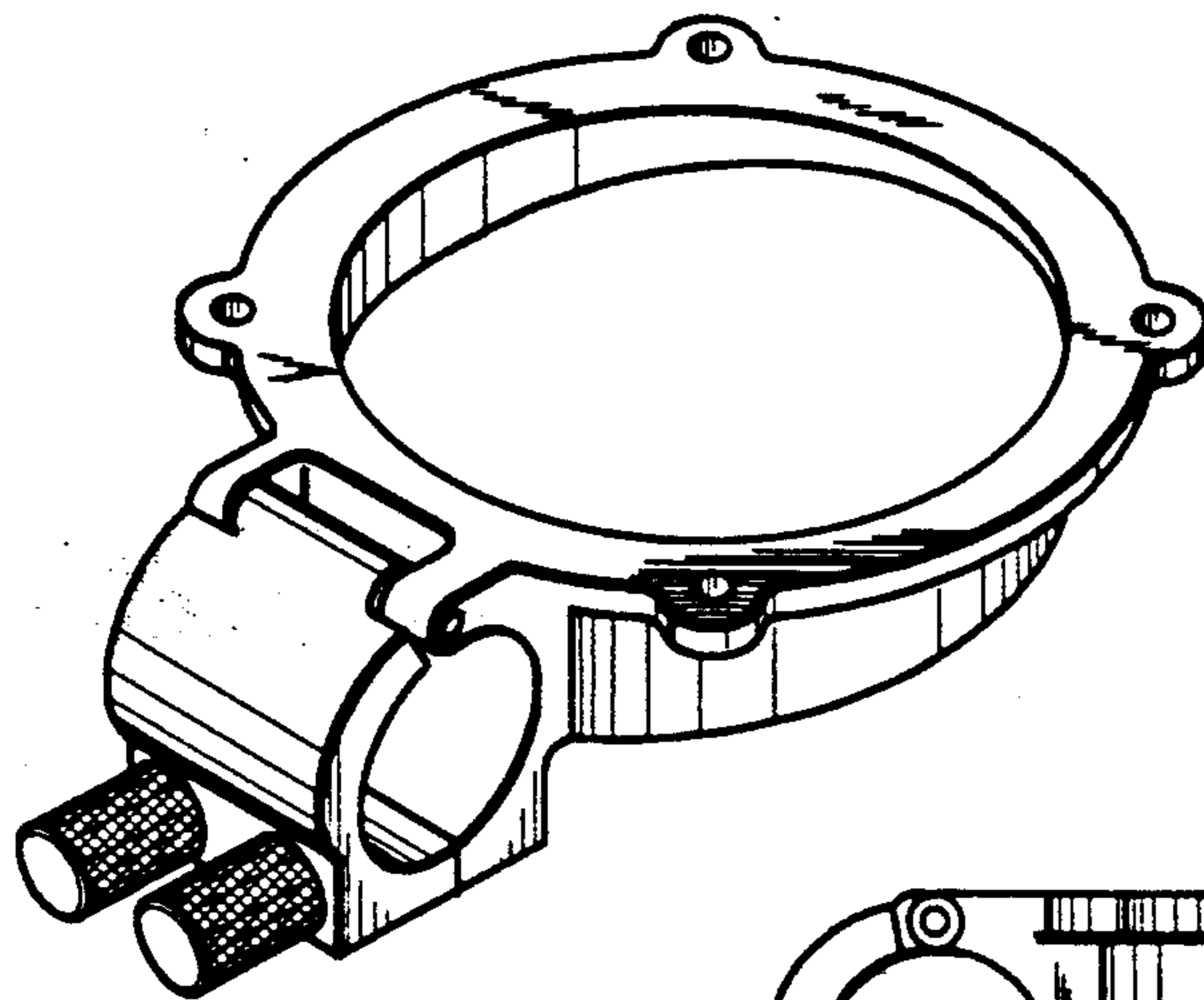

FIG. 7.

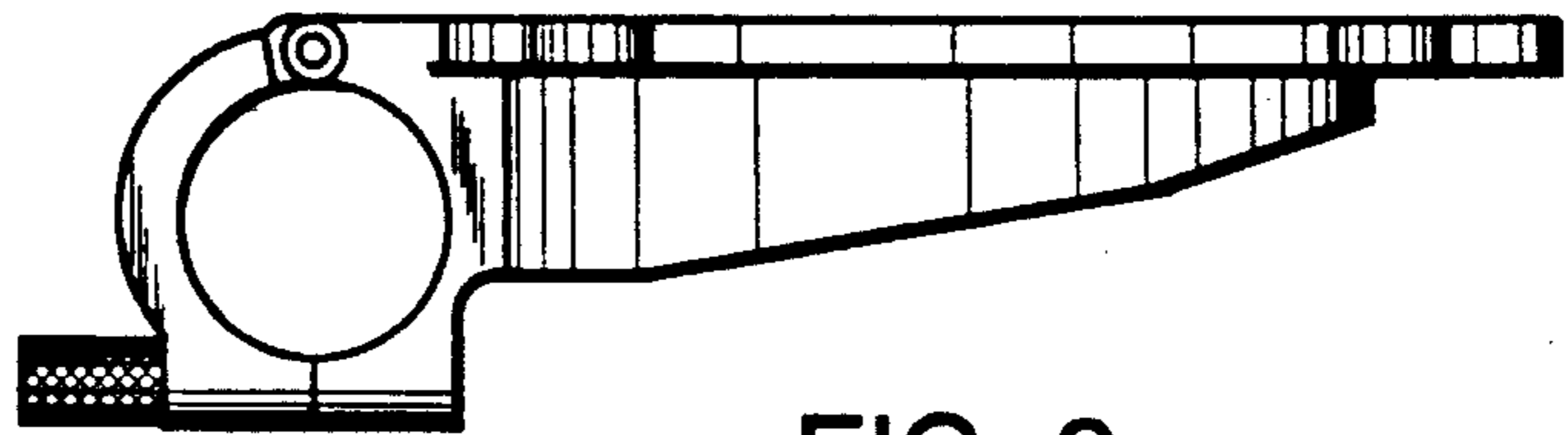

FIG. 8.

FIG. 9.

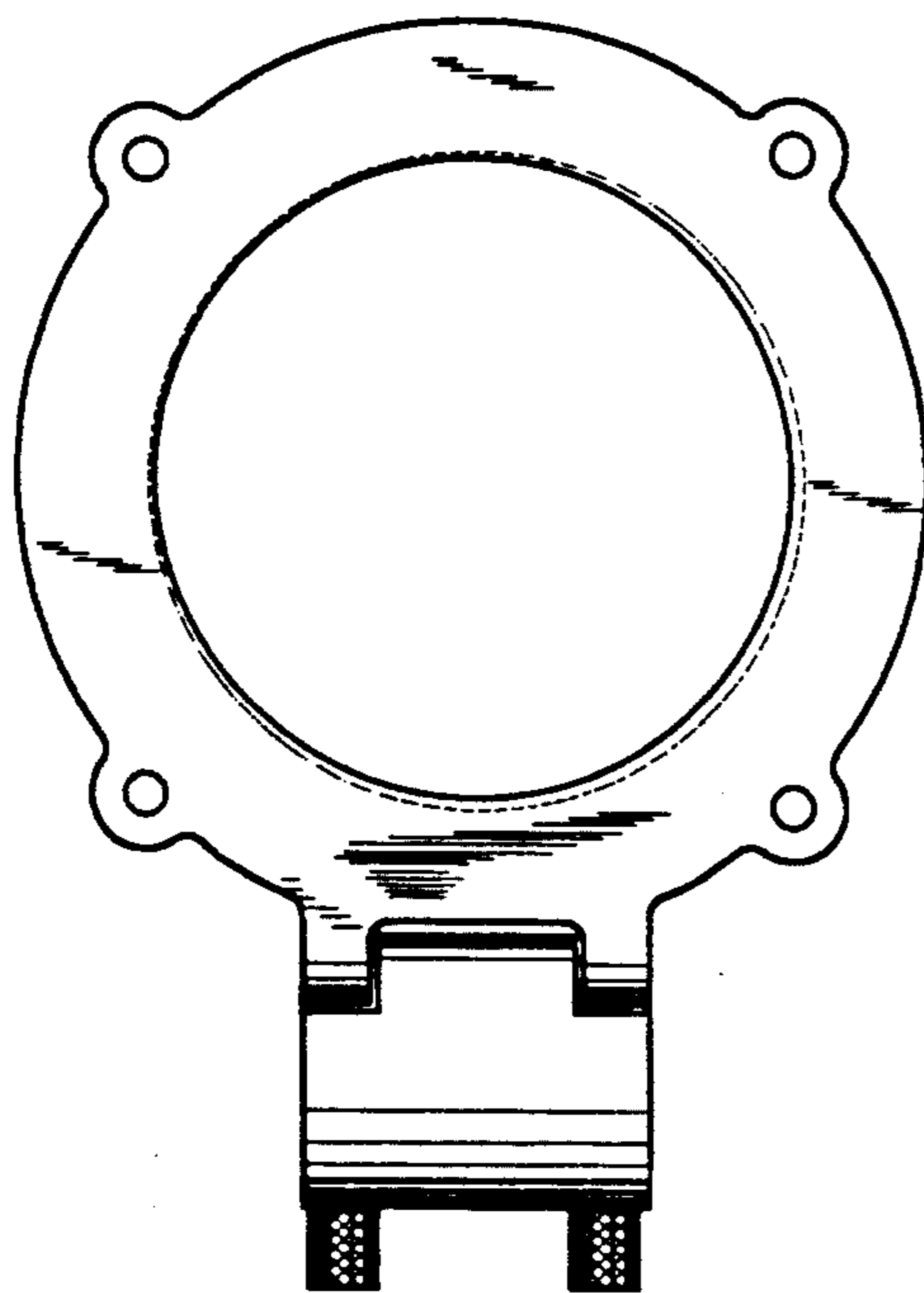

FIG. 11.

FIG. 10.

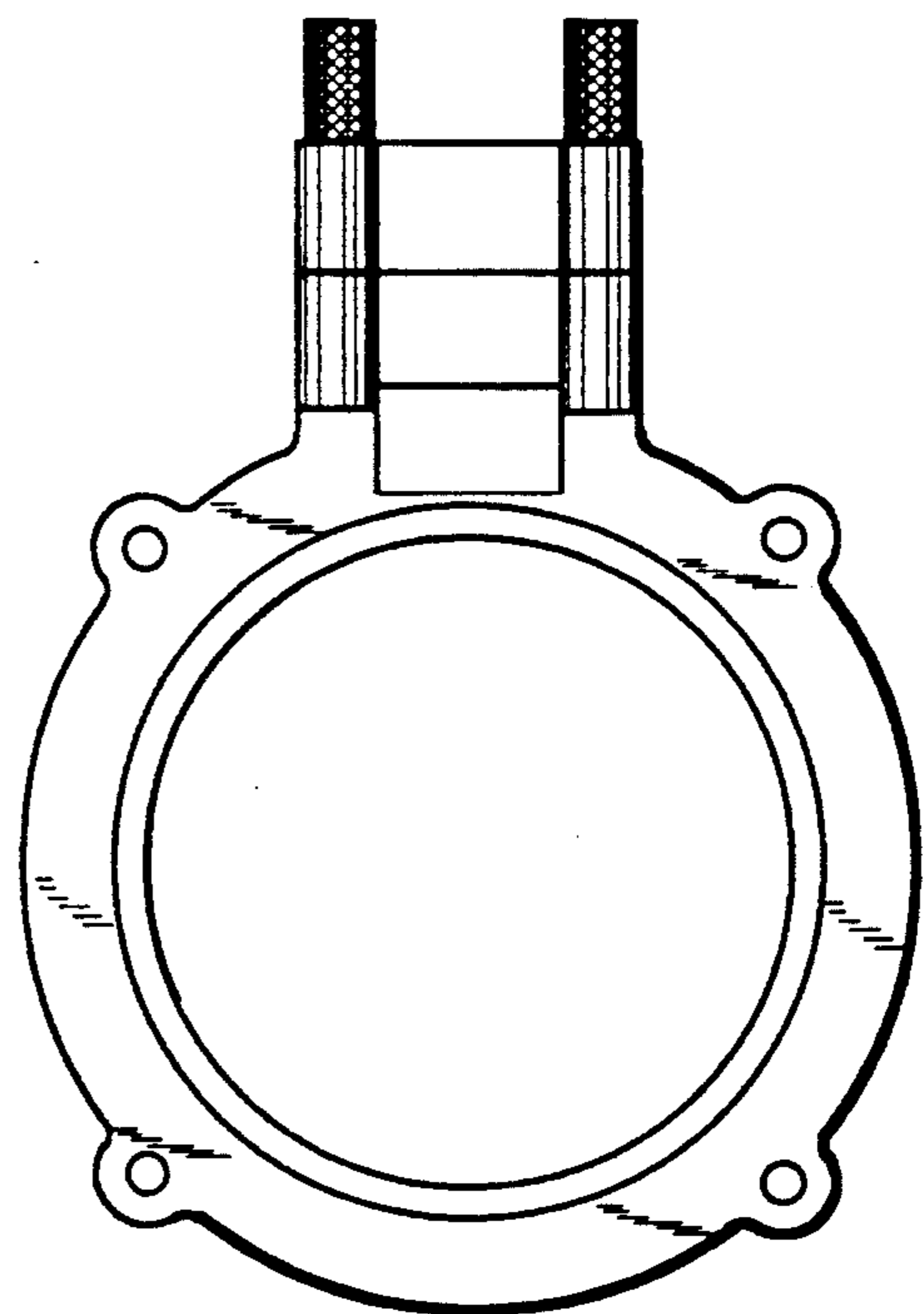

FIG. 12.

