



US00D343531S

United States Patent [19]

[11] Patent Number: **Des. 343,531**

Hagopian

[45] Date of Patent: **** Jan. 25, 1994**

[54] **FLOTATION THERAPY BED**

[75] Inventor: **Mark Hagopian**, Indian Rocks Beach, Fla.

[73] Assignee: **Biologics, Inc.**, St. Petersburg, Fla.

[**] Term: **14 Years**

[21] Appl. No.: **691,591**

[22] Filed: **Apr. 25, 1991**

[52] U.S. Cl. **D6/393; D6/382; D6/383**

[58] Field of Search **D6/382-385, D6/389-395, 397, 505-508; 5/600, 912, 917, 918; D24/183**

[56] **References Cited**

U.S. PATENT DOCUMENTS

D. 192,910 5/1962 Sundberg et al. D24/183 X

D. 288,874 3/1987 Yosimoto D6/382
4,650,171 3/1987 Haworth 5/600
4,835,802 6/1989 Purcey et al. 5/912 X

Primary Examiner—Nelson C. Holtje
Assistant Examiner—J. E. Seeger
Attorney, Agent, or Firm—Joseph C. Mason, Jr.; Ronald E. Smith

[57] **CLAIM**

The ornamental design for flotation therapy bed, as shown.

DESCRIPTION

FIG. 1 is a side elevational view of a flotation therapy bed, showing my new design;
FIG. 2 is a top plan view thereof;
FIG. 3 is a front end elevational view thereof;
FIG. 4 is a rear end elevational view thereof;
FIG. 5 is a bottom plan view thereof; and,
FIG. 6 is a perspective view thereof.

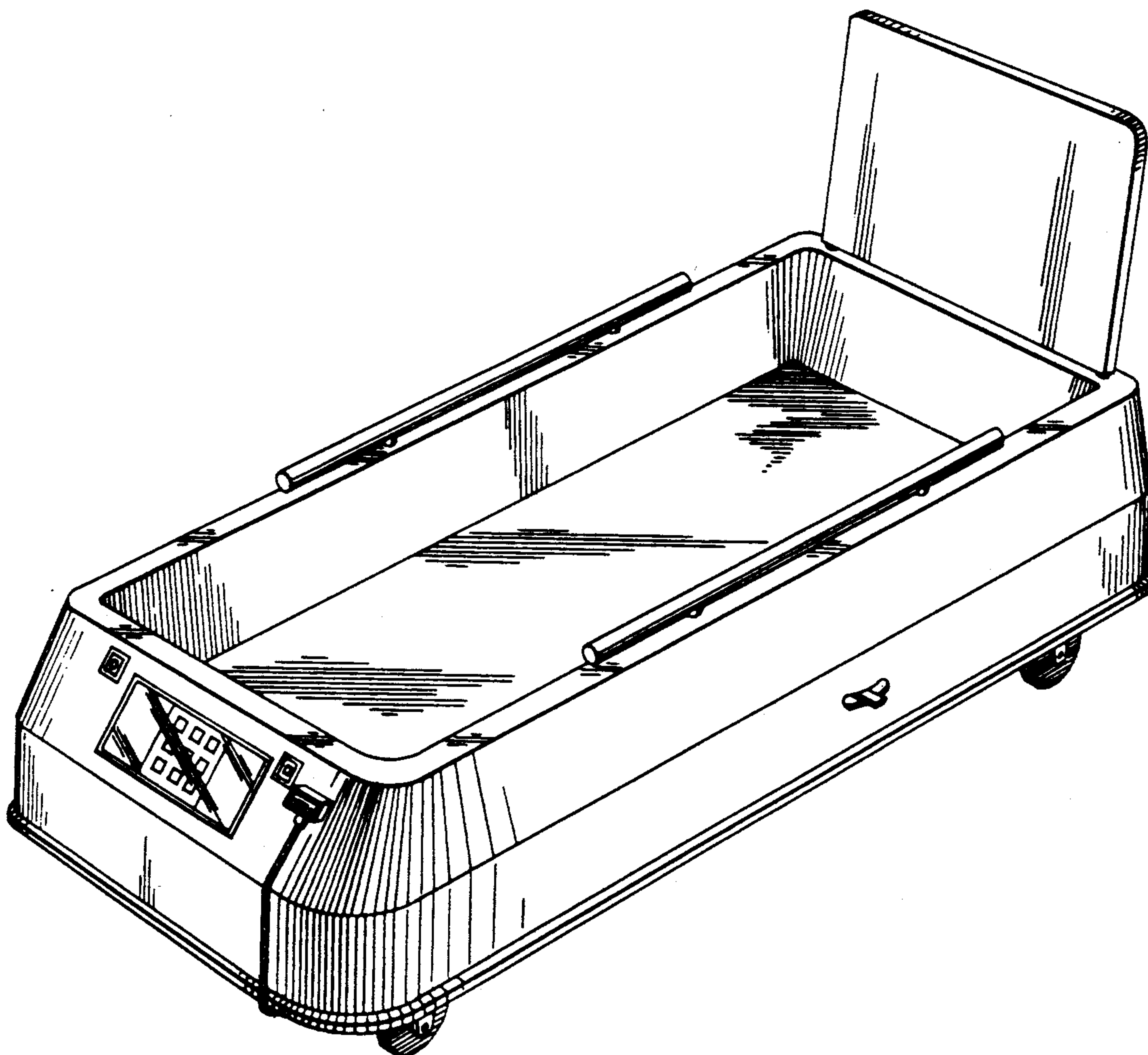

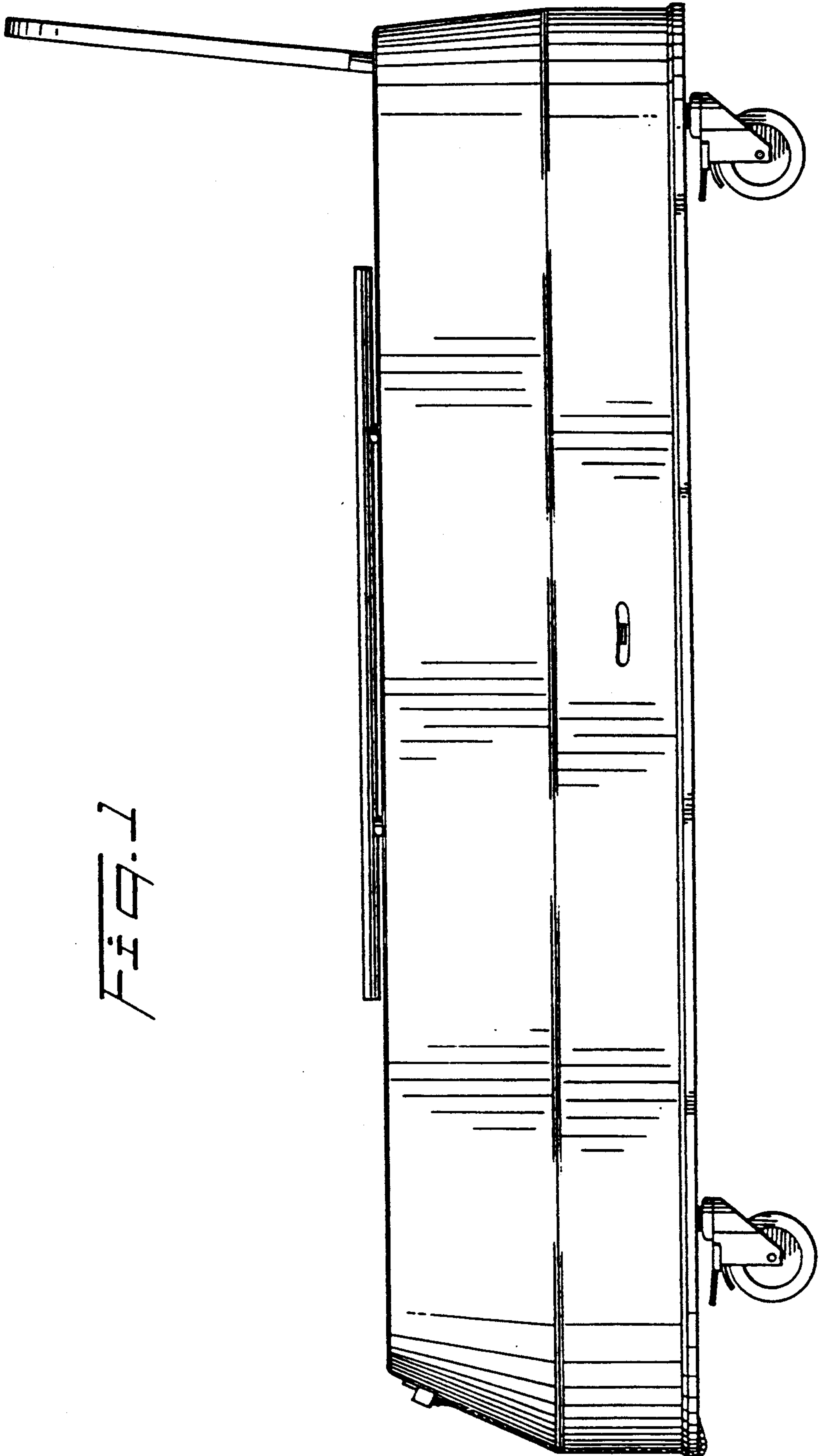
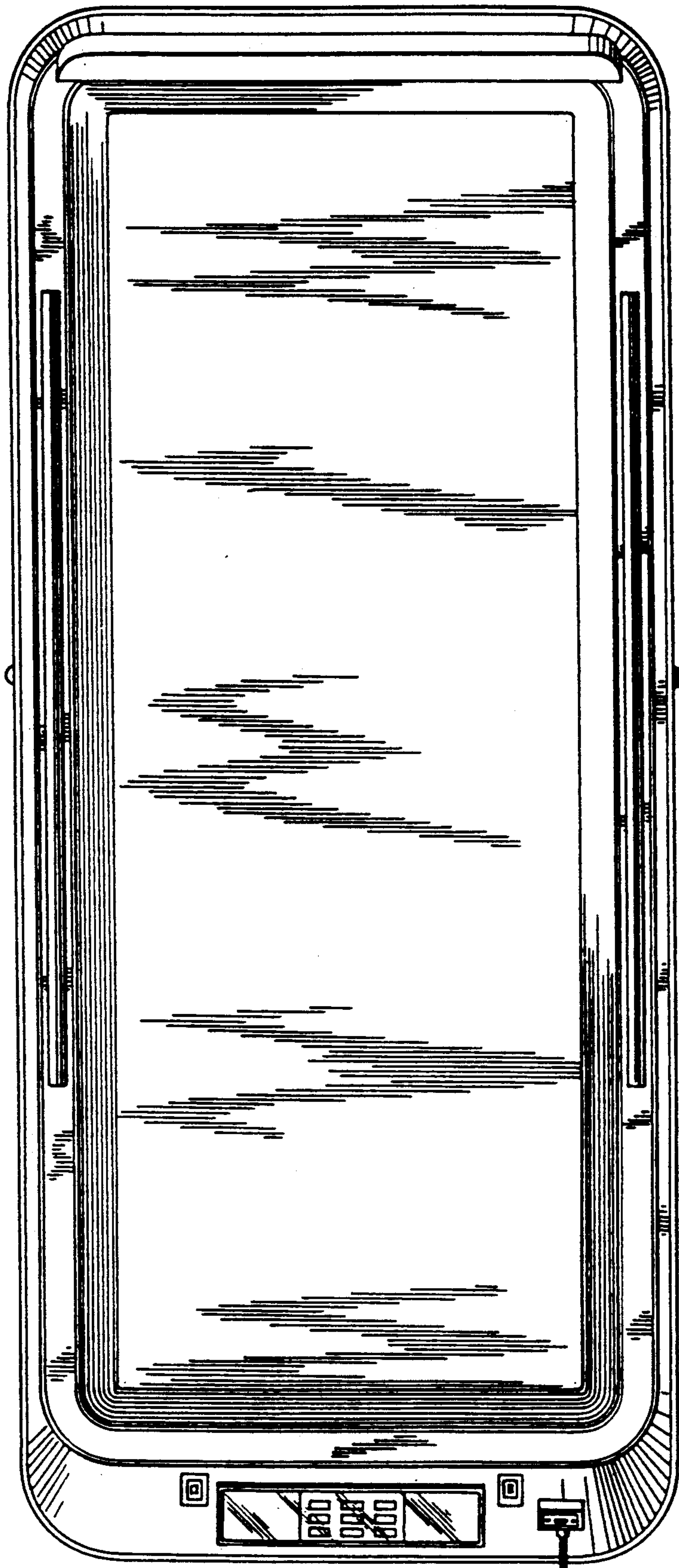

FIG. 1

FIG. 2



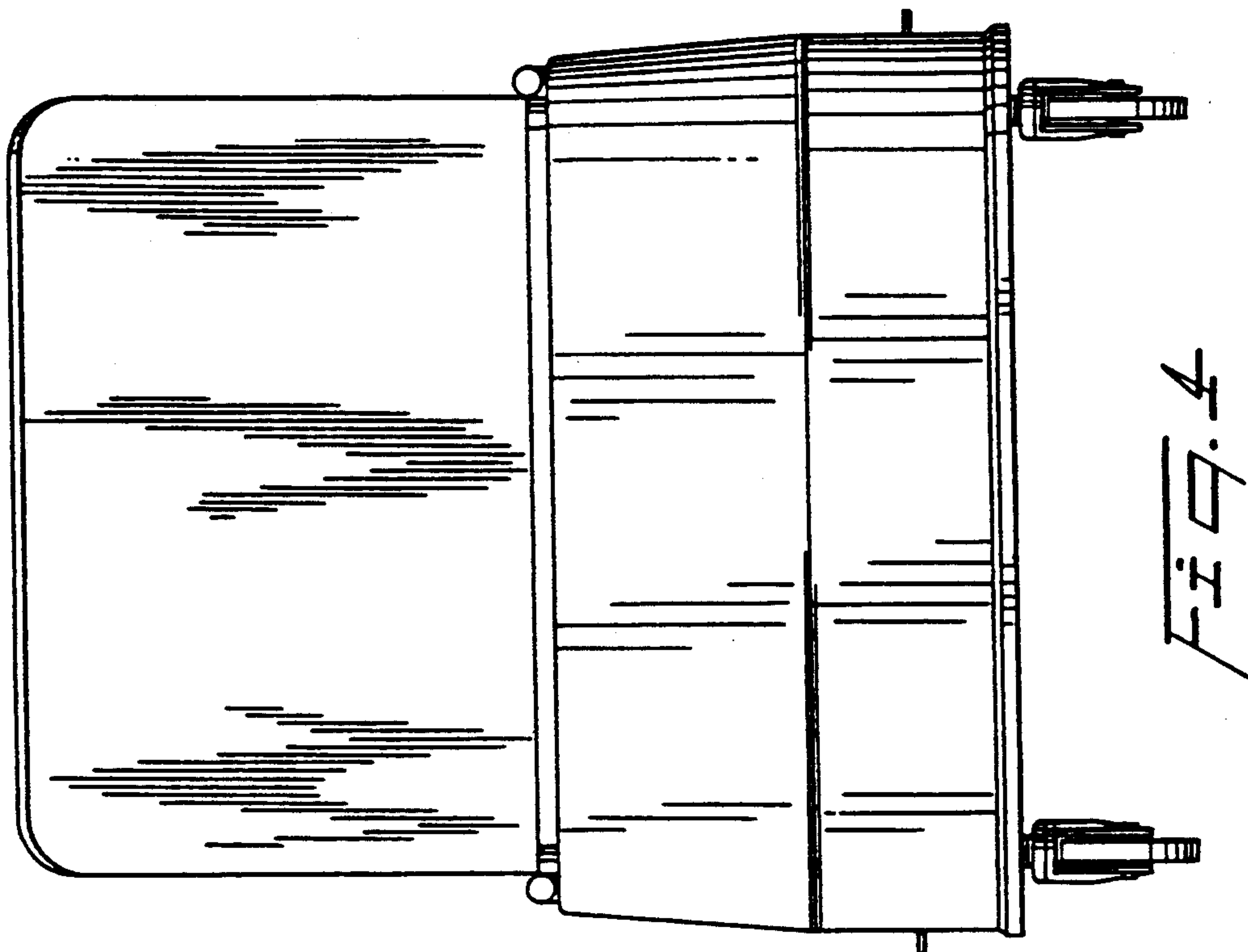

FIG. 3

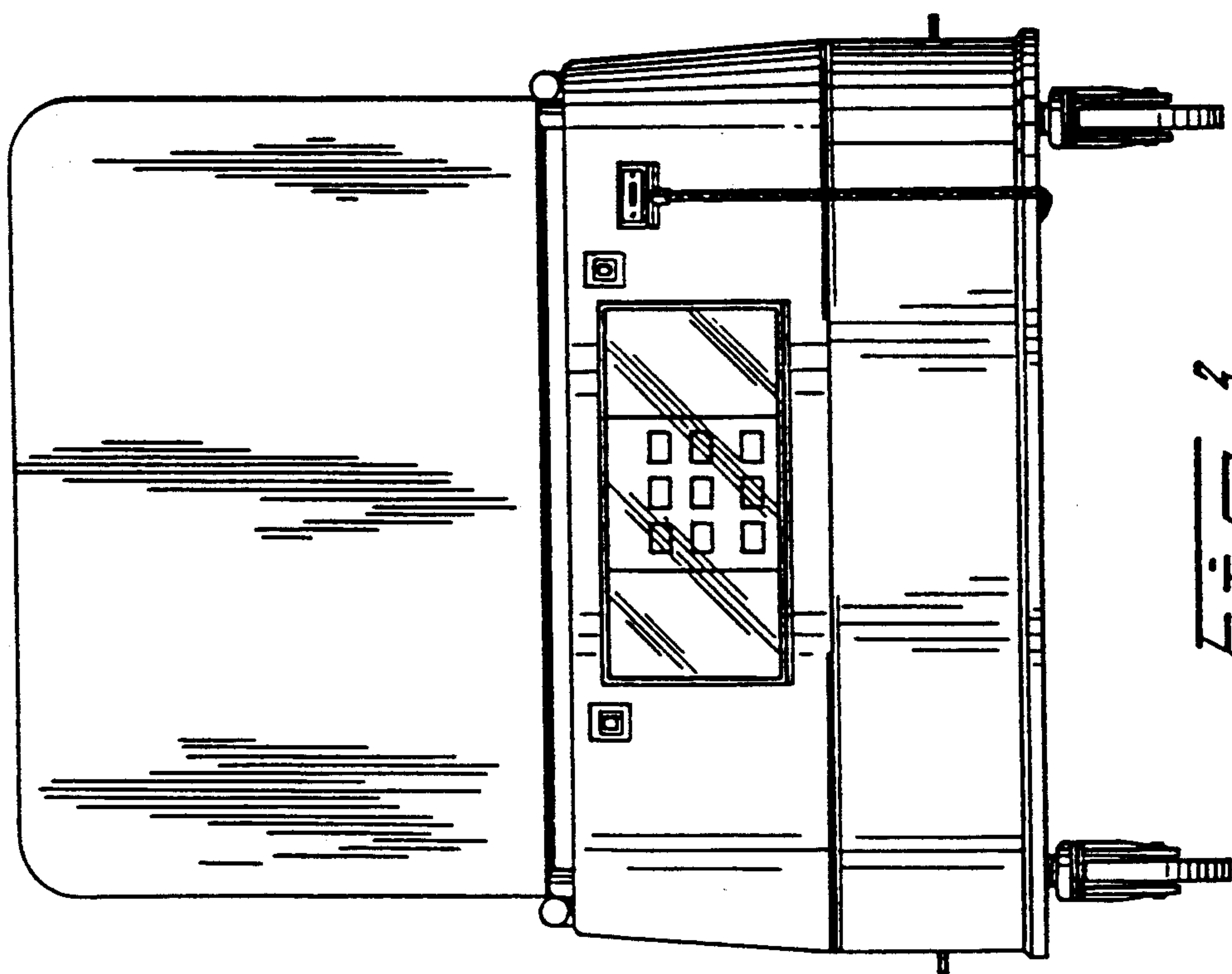

FIG. 4

FIG. 5

