



US00D343369S

United States Patent [19] Sprague

[11] Patent Number: **Des. 343,369**

[45] Date of Patent: **** Jan. 18, 1994**

[54] **HIGHWAY BARRIER**

[76] Inventor: **R. Paul Sprague**, 350 Indian Rock Rd., New Canaan, Conn. 06840

[**] Term: **14 Years**

[21] Appl. No.: **825,712**

[22] Filed: **Jan. 27, 1992**

[52] U.S. Cl. **D10/109**

[58] Field of Search 256/13.1; 116/63 R, 116/63 P, 63 C, 63 T; 404/6; D25/58, 44; D10/109, 113

3,678,815	7/1972	Yunker	256/13.1
3,917,232	11/1975	Lindner	D10/109
3,980,279	9/1976	Bolinger	256/13.1
4,312,600	1/1982	Schaag et al.	116/63 P
4,773,629	9/1988	Yodock	256/13.1
4,954,009	9/1990	Kellison	256/13.1

Primary Examiner—A. Hugo Word
Assistant Examiner—Doris Clark
Attorney, Agent, or Firm—Spencer E. Olson

[57] **CLAIM**

The ornamental design for a highway barrier, as shown.

DESCRIPTION

FIG. 1 is a perspective view of a highway barrier embodying my design;
FIG. 2 is a side elevational view thereof;
FIG. 3 is a top plan view thereof;
FIG. 4 is a bottom view; and,
FIG. 5 is an end elevational view thereof.

[56] **References Cited**

U.S. PATENT DOCUMENTS

D. 235,989	7/1975	Richardson	125/44
D. 276,142	10/1984	Dobrin	D10/106
D. 278,416	4/1985	Moran	D10/109

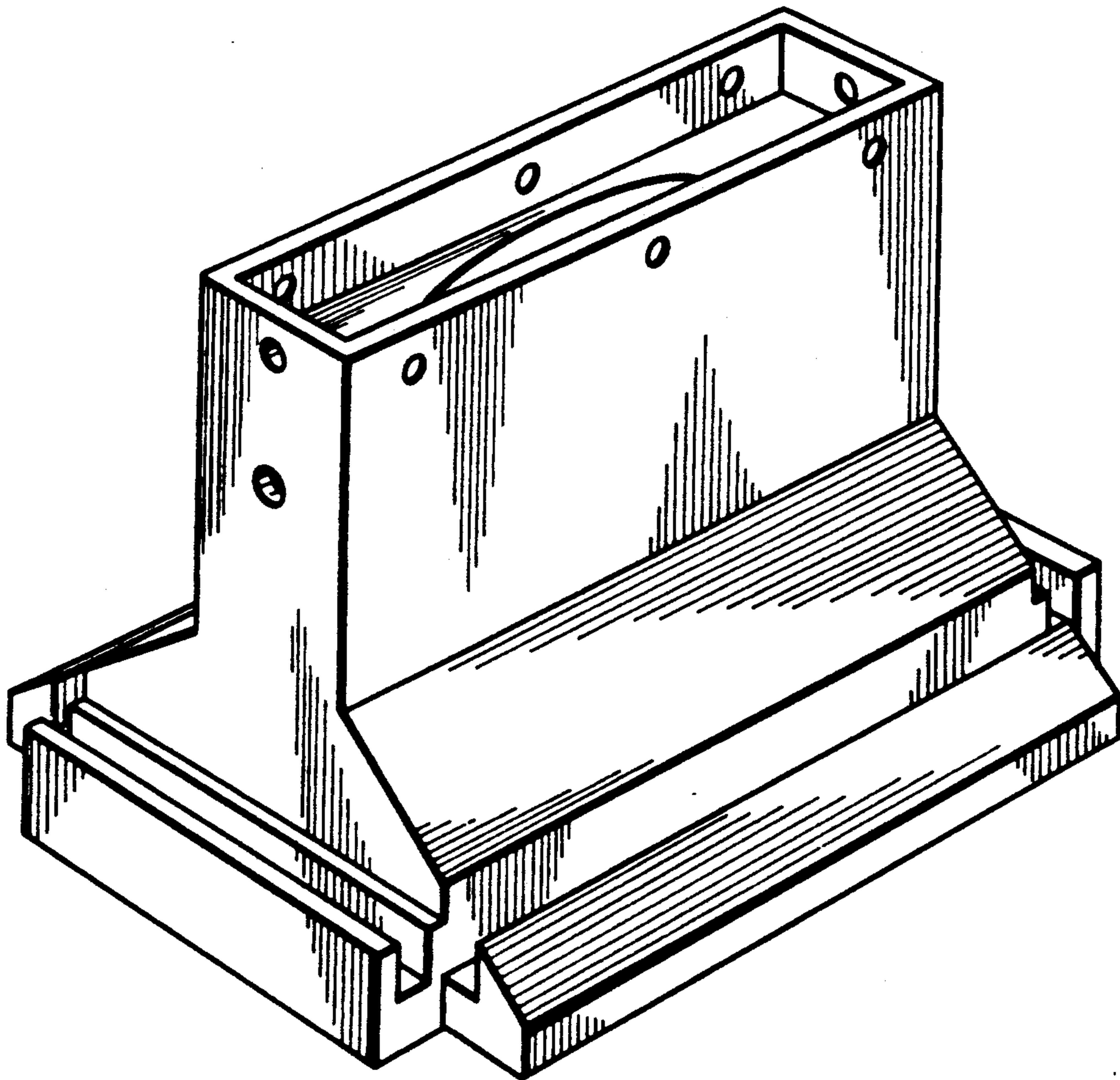

FIG. 1.

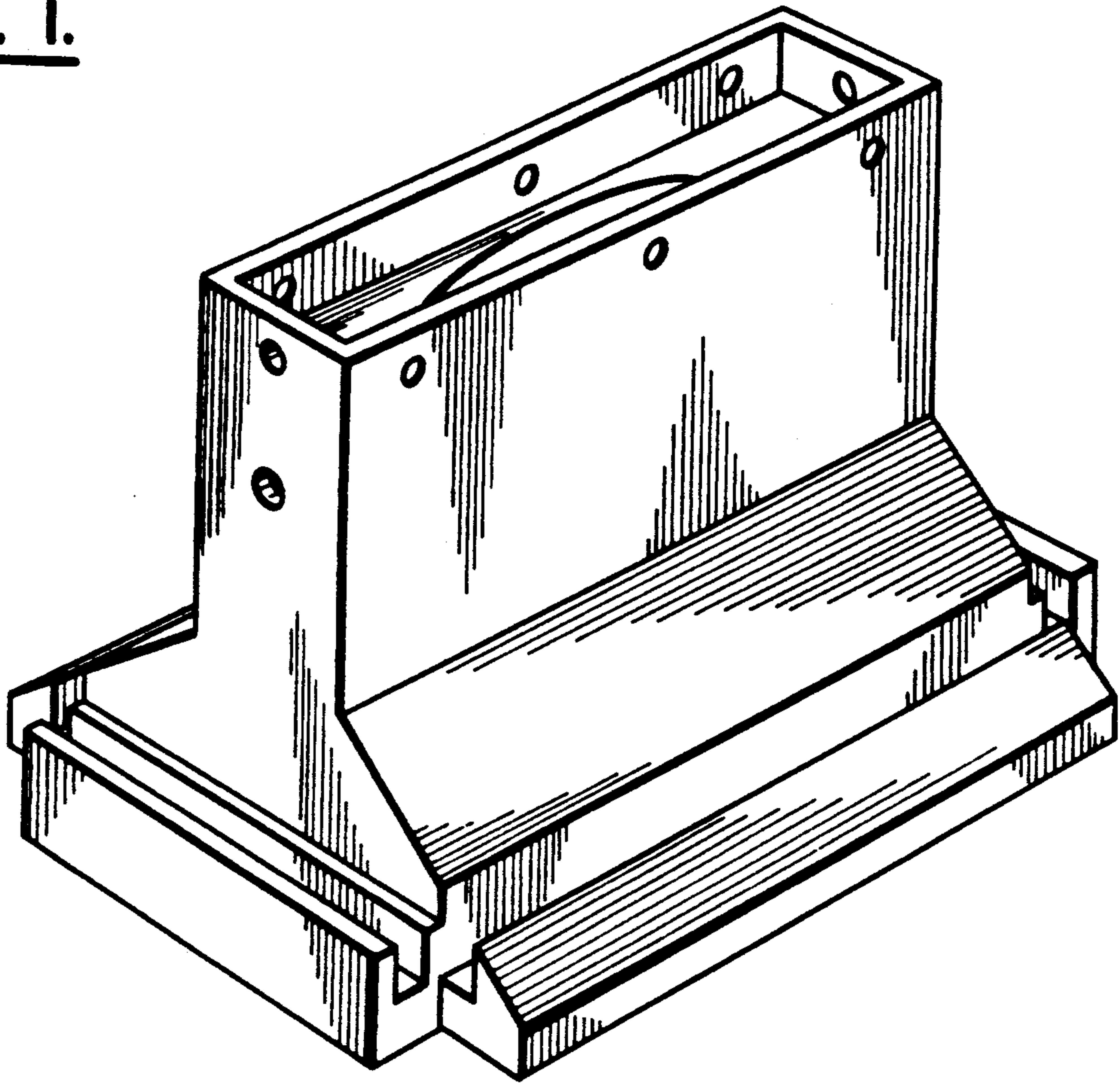

FIG. 2.

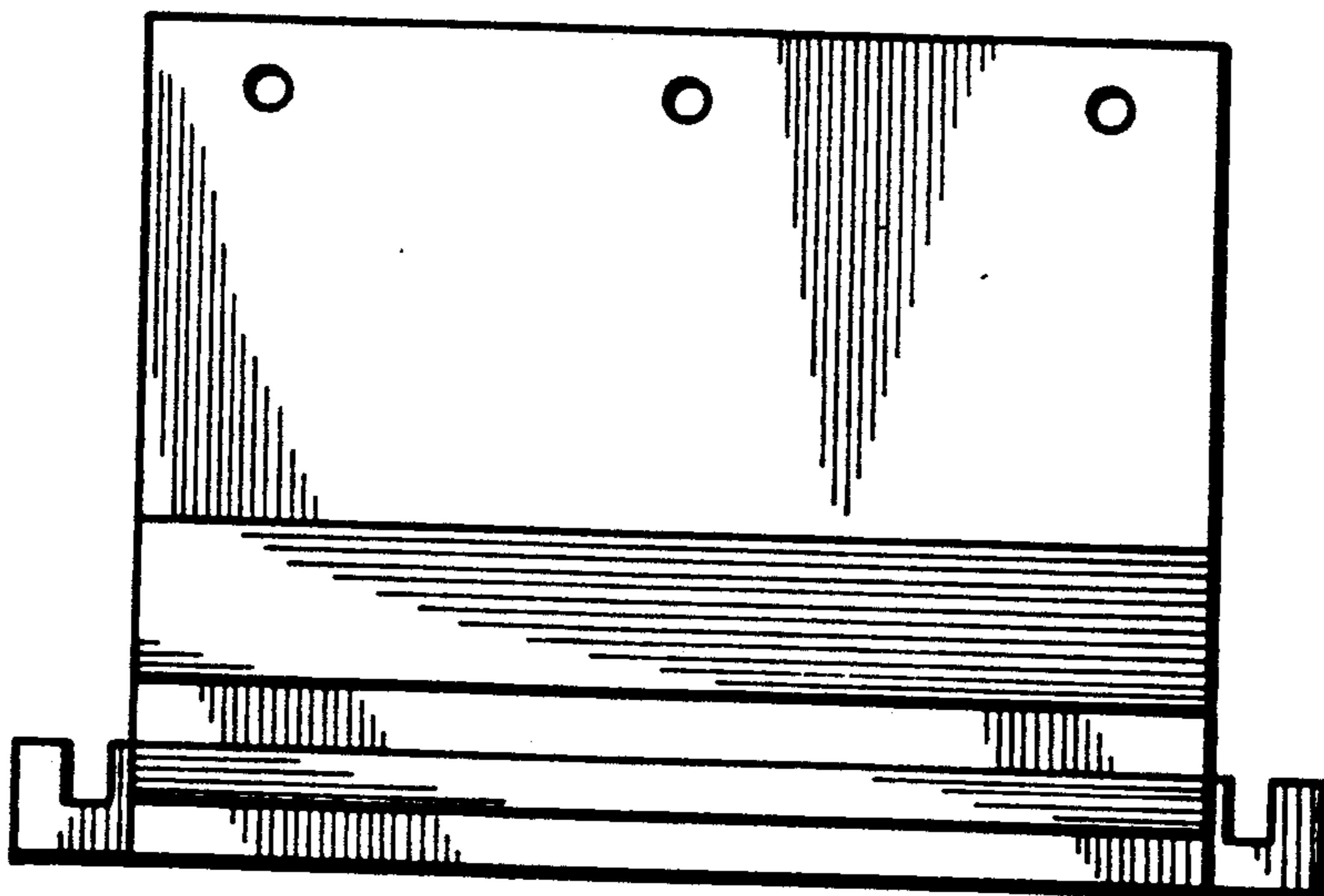

FIG. 3.

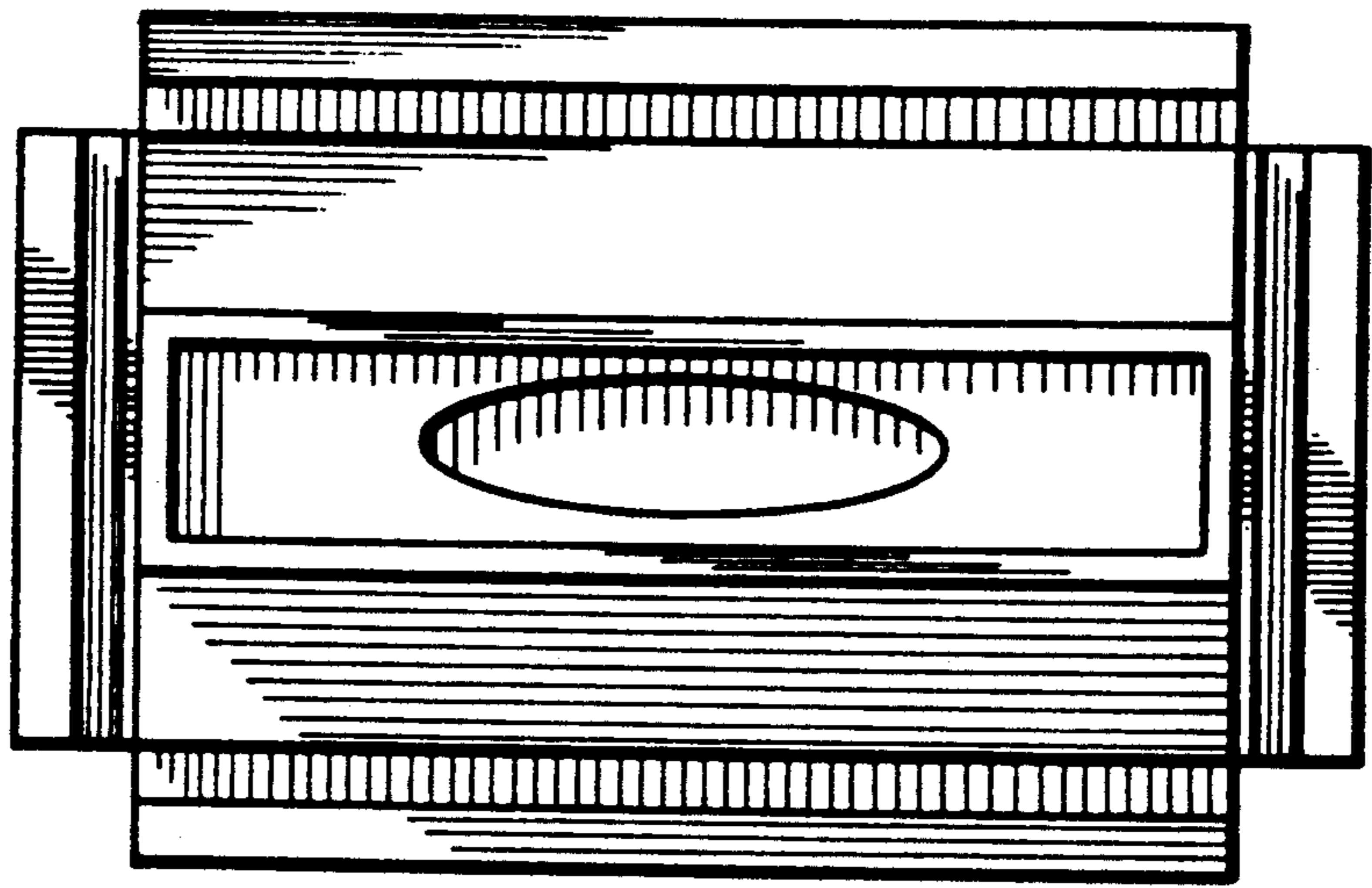

FIG. 4.

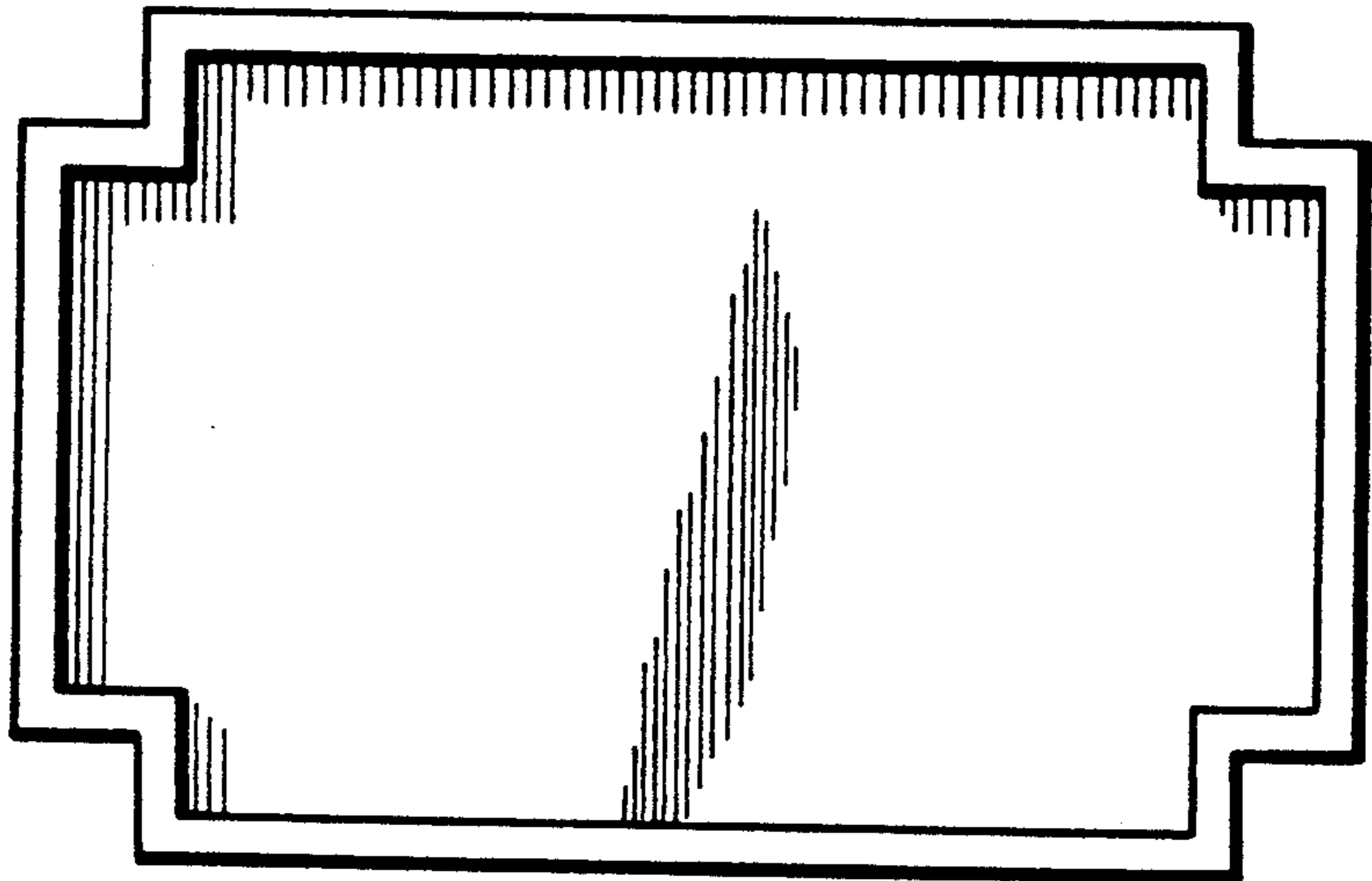

FIG. 5.

