



US00D343244S

United States Patent [19]

[11] Patent Number: **Des. 343,244**

Belisle

[45] Date of Patent: **** Jan. 11, 1994**

[54] **SUSPENDED LUMINAIRE**

[56] **References Cited**

U.S. PATENT DOCUMENTS

[75] Inventor: **William W. Belisle, Newark, Ohio**

D. 300,469	3/1989	Ewing et al.	D26/24
4,449,168	5/1984	Ewing	362/147 X
4,837,669	6/1989	Tharp	362/147 X

[73] Assignee: **Holophane Company, Inc., Newark, Ohio**

Primary Examiner—Susan J. Lucas
Attorney, Agent, or Firm—Brooks & Kushman

[**] Term: **14 Years**

[57] **CLAIM**

The ornamental design for a suspended luminaire, as shown.

[21] Appl. No.: **857,300**

DESCRIPTION

[22] Filed: **Mar. 25, 1992**

FIG. 1 is a perspective view of my new design;

[52] U.S. Cl. **D26/85**

FIG. 2 is a front elevational view;

[58] Field of Search 362/147, 404-408;

FIG. 3 is a right side elevational view;

D26/24, 72, 80-92

FIG. 4 is a top plan view;

FIG. 5 is a bottom plan view; and,

FIG. 6 is a rear elevational view.

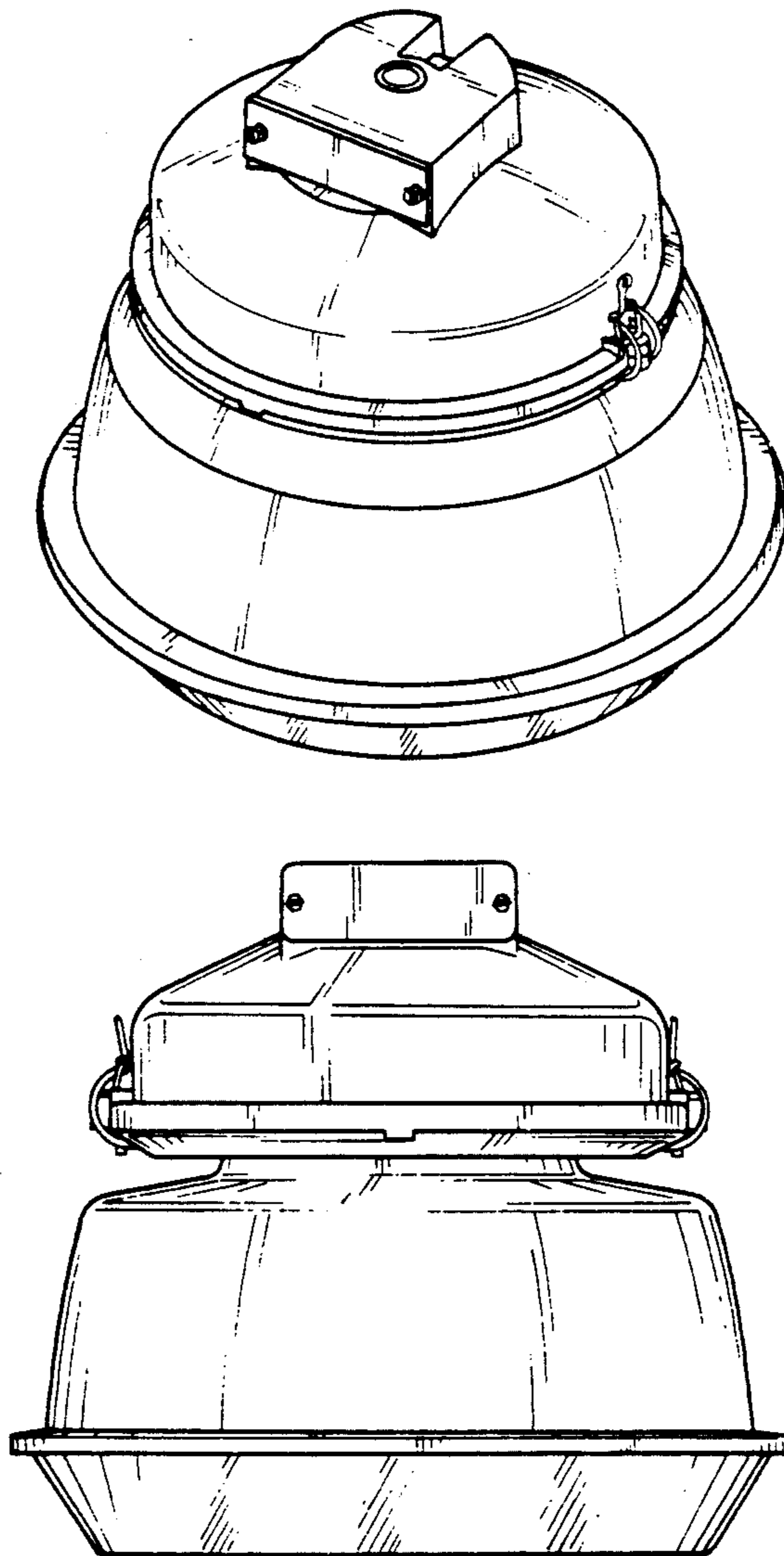

Fig-1

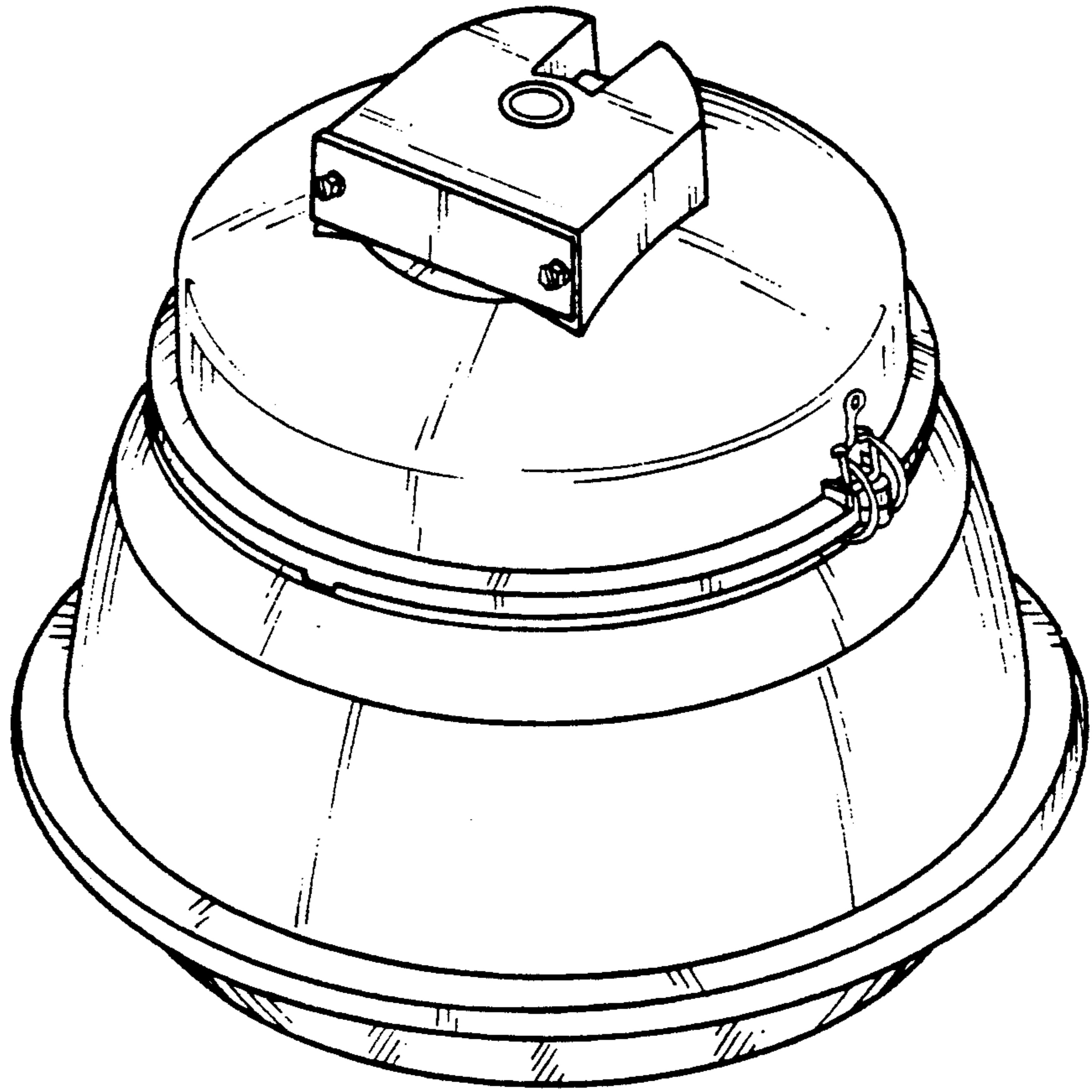
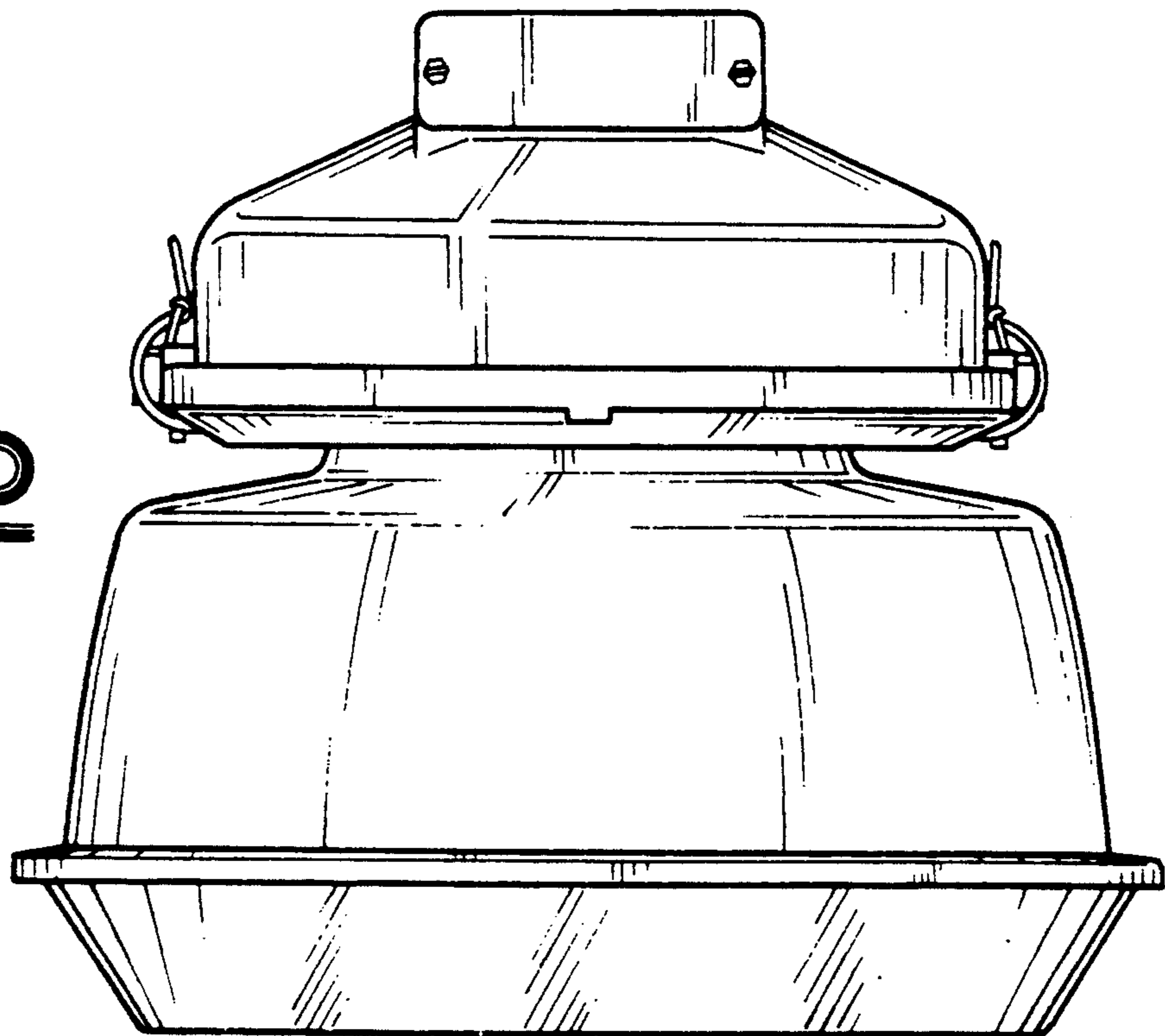

Fig-2



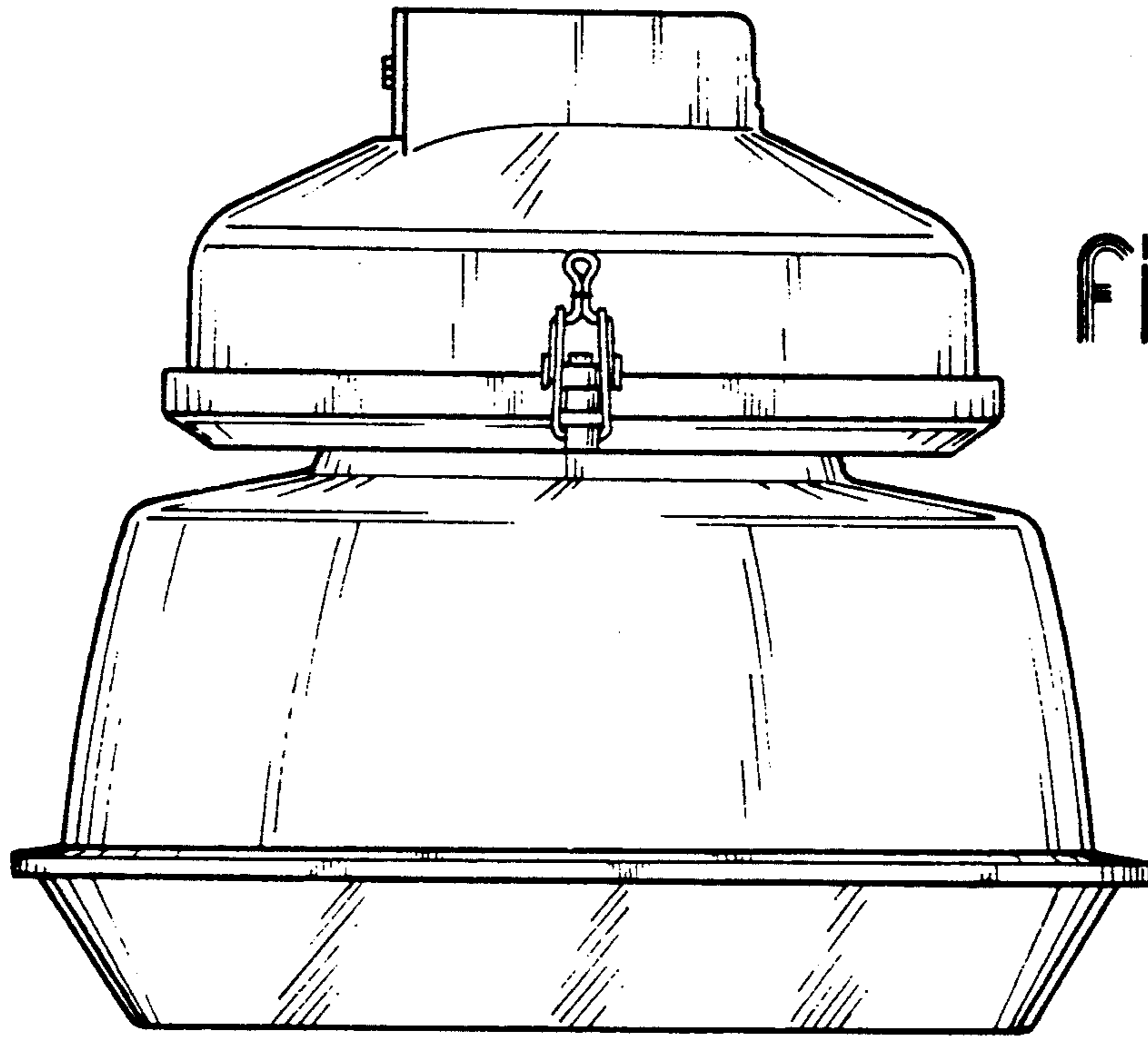

fig-3

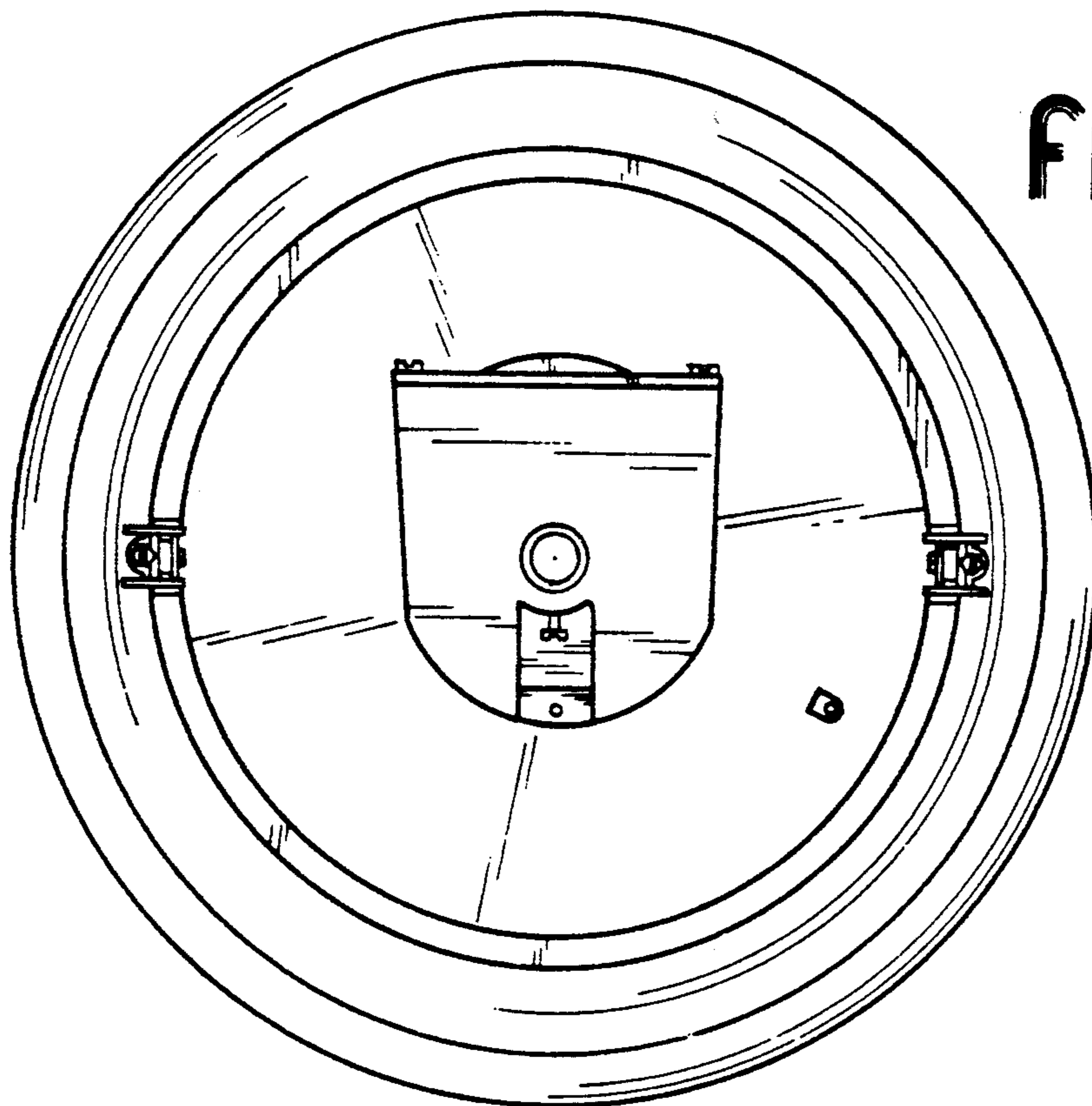

fig-4

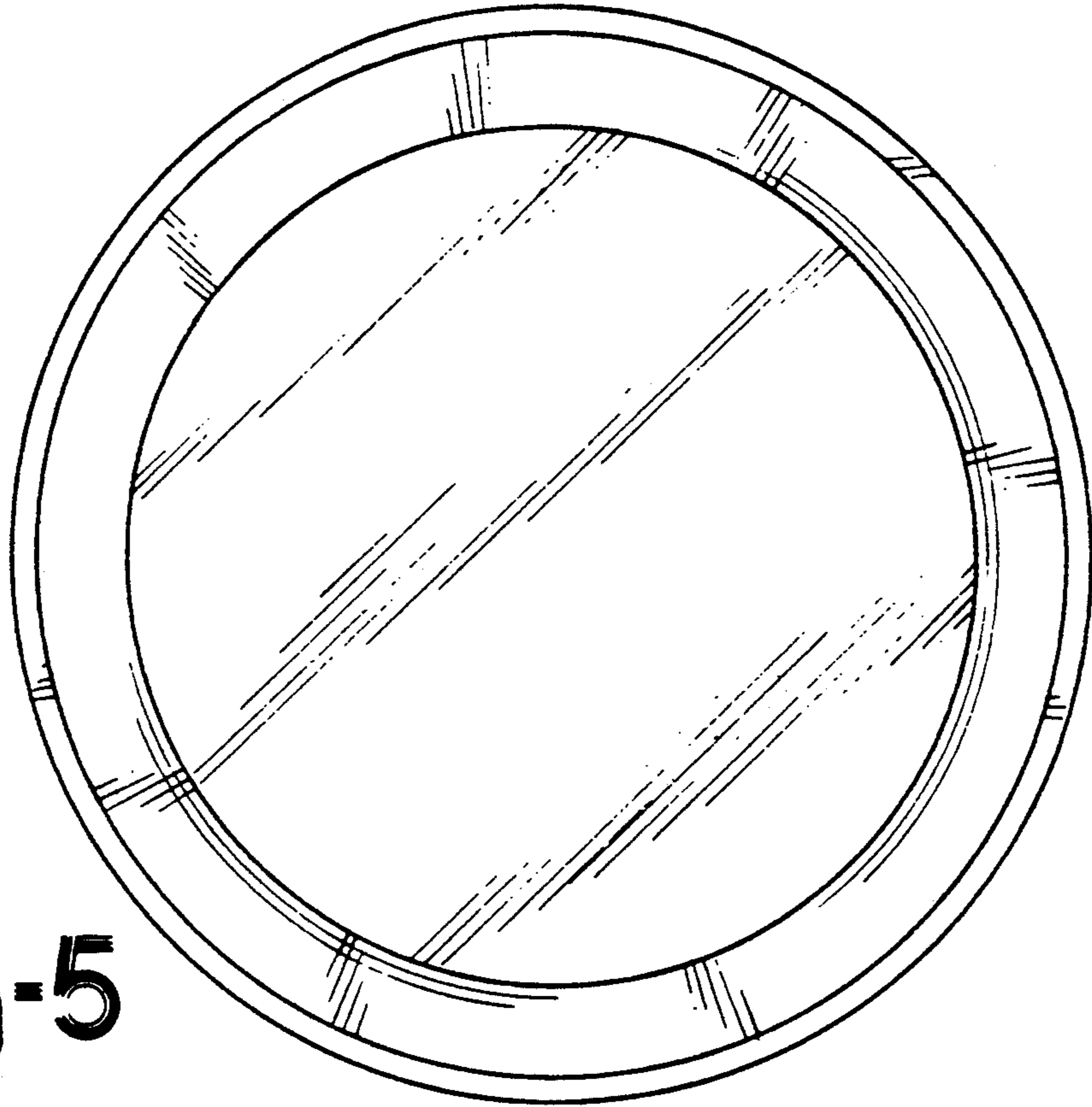

fig-5

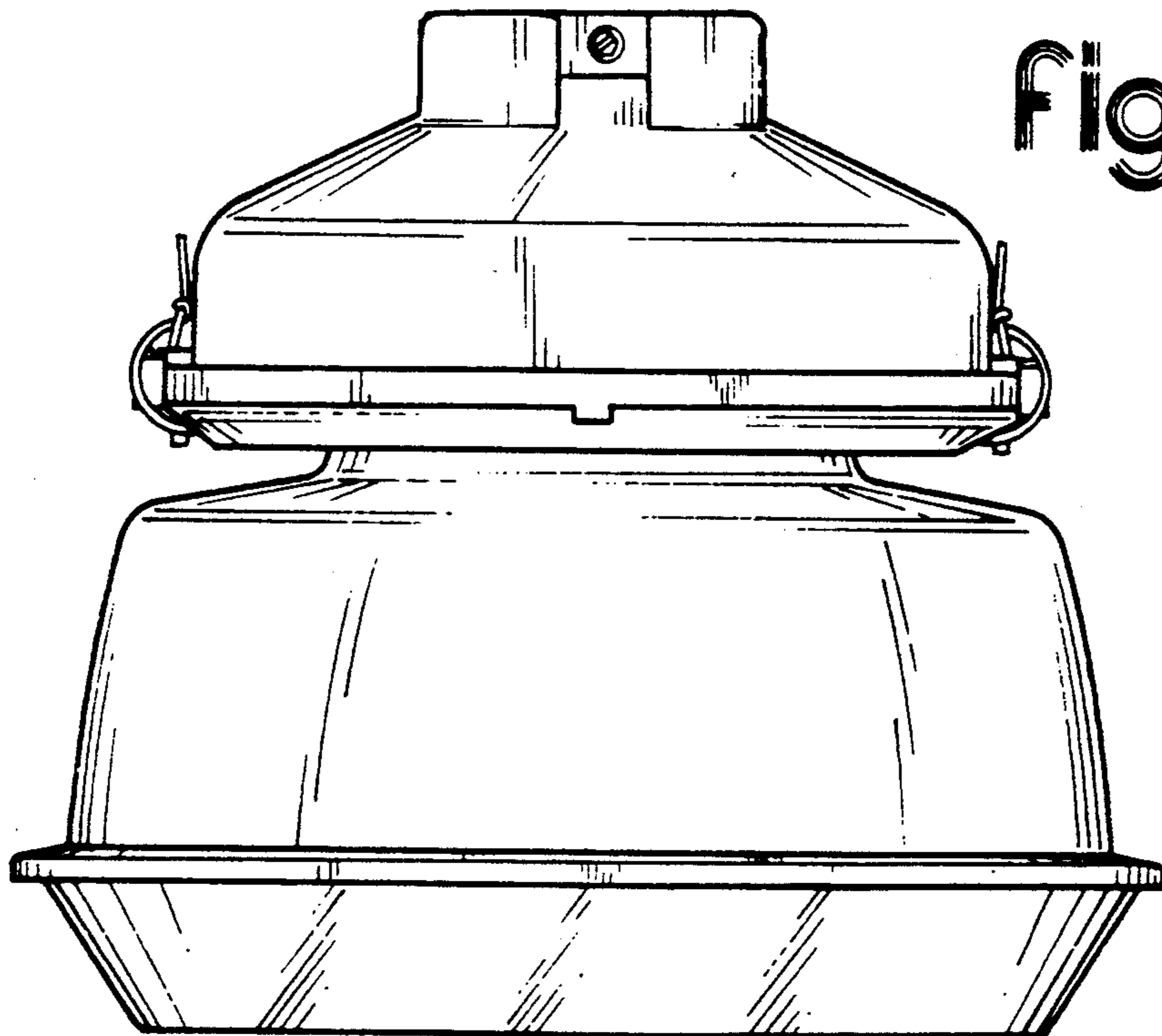

fig-6