



US00D343158S

# United States Patent [19]

[11] Patent Number: **Des. 343,158**

Thomas, Jr. et al.

[45] Date of Patent: **\*\* Jan. 11, 1994**

## [54] SUNVISOR

[75] Inventors: **Paul Thomas, Jr.; Kirk Thomas**, both of Daleville, Ala.; **Carl M. Davis, II**, Atlanta, Ga.

[73] Assignee: **VMC Fiberglass Products, Inc.**, Daleville, Ala.

[\*\*] Term: **14 Years**

[21] Appl. No.: **922,102**

[22] Filed: **Jul. 29, 1992**

[52] U.S. Cl. .... **D12/191**

[58] Field of Search ..... 296/95.1; 160/370.2, 160/DIG.3; D12/191

## [56] References Cited

### U.S. PATENT DOCUMENTS

D. 239,705	4/1976	Lund	.....	D12/191
D. 273,672	5/1984	Lund	.....	D12/191
D. 286,143	10/1986	Lund	.....	D12/181
D. 288,309	2/1987	Lund	.....	D12/191
D. 288,310	2/1987	Lund	.....	D12/191
D. 291,295	8/1987	Lund	.....	D12/191
D. 303,239	7/1987	Gempel et al.	.....	D12/191
D. 319,209	8/1991	Miller et al.	.....	D12/191
D. 330,359	10/1992	Addeo et al.	.....	D12/191
D. 330,533	10/1992	Orth, Sr. et al.	.....	D12/191
D. 330,534	10/1992	Fink	.....	D12/191

Primary Examiner—James M. Gandy

Attorney, Agent, or Firm—Kennedy & Kennedy

## [57] CLAIM

The ornamental design for a sunvisor, as shown and described.

## DESCRIPTION

FIG. 1 is an upper and right perspective view of a sunvisor showing our new design, attached to a pickup truck shown in broken lines to illustrate the environment thereof;

FIG. 2 is a right side elevational view thereof, the left side being a mirror image of the right side shown;

FIG. 3 is a front elevational view thereof;

FIG. 4 is a back elevational view thereof;

FIG. 5 is a top plan view thereof;

FIG. 6 is a bottom plan view thereof;

FIG. 7 is an upper and right perspective view of a second embodiment of our sunvisor attached to a pickup truck shown in broken lines to illustrate the environment thereof;

FIG. 8 is a right side elevational view thereof, the left side being a mirror image of the right side shown;

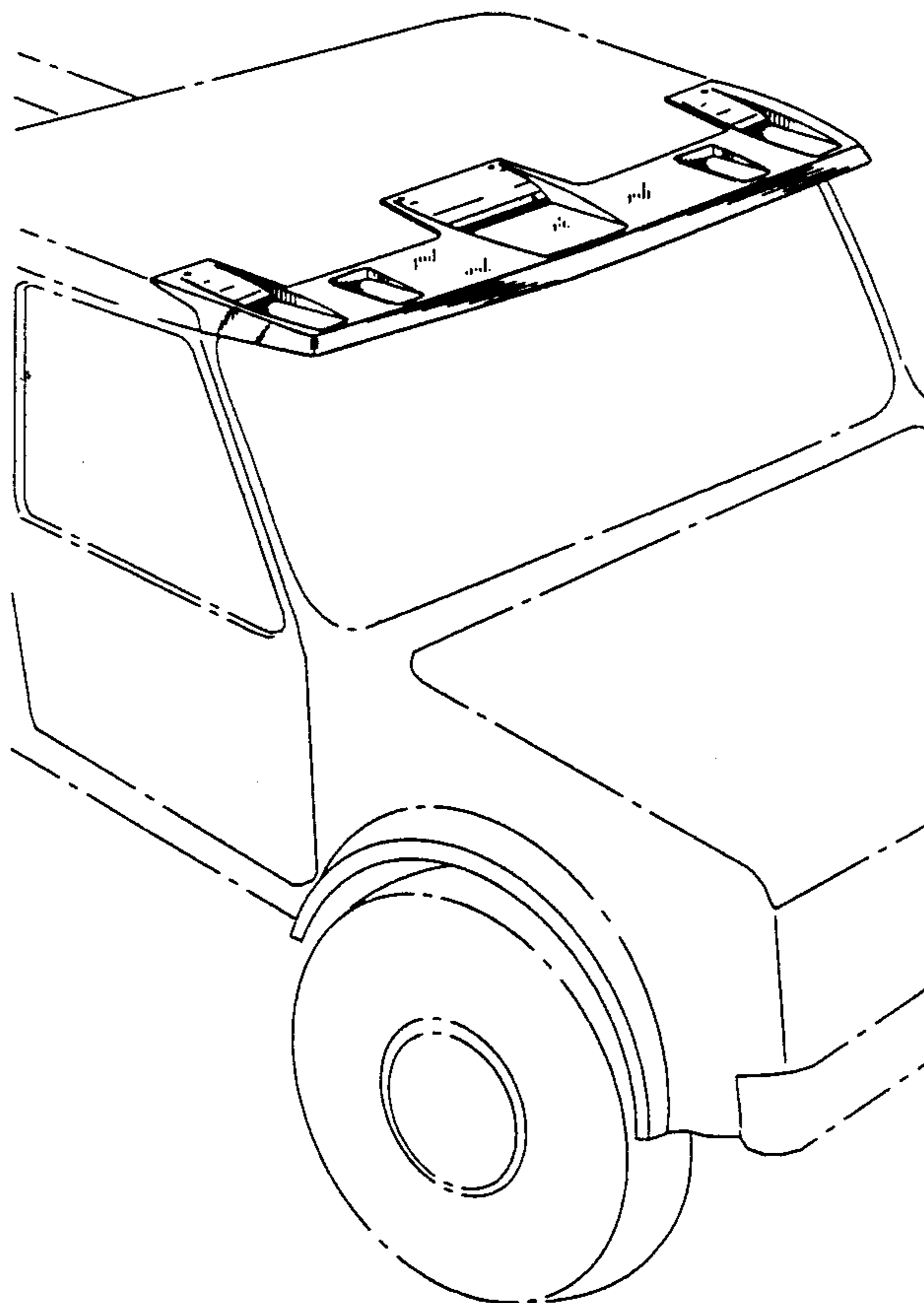
FIG. 9 is a front elevational view thereof;

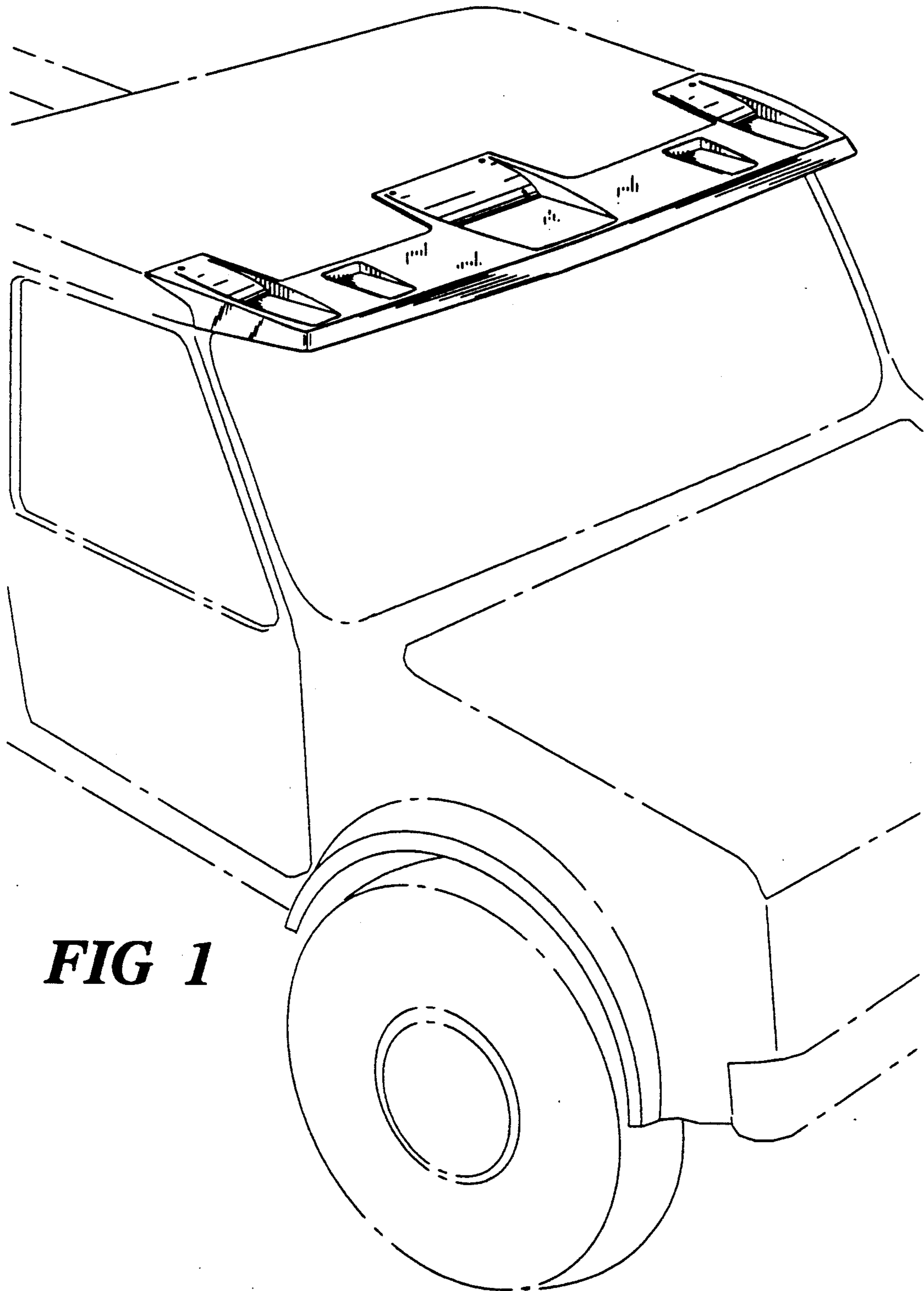
FIG. 10 is a back elevational view thereof;

FIG. 11 is a top plan view thereof; and,

FIG. 12 is a bottom plan view thereof.

The broken line representation of a pickup truck on FIGS. 1, and 7 of the drawing is for illustrative purposes only and forms no part of the claimed design.

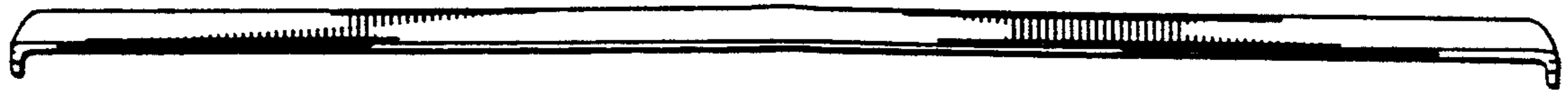




**FIG 1**



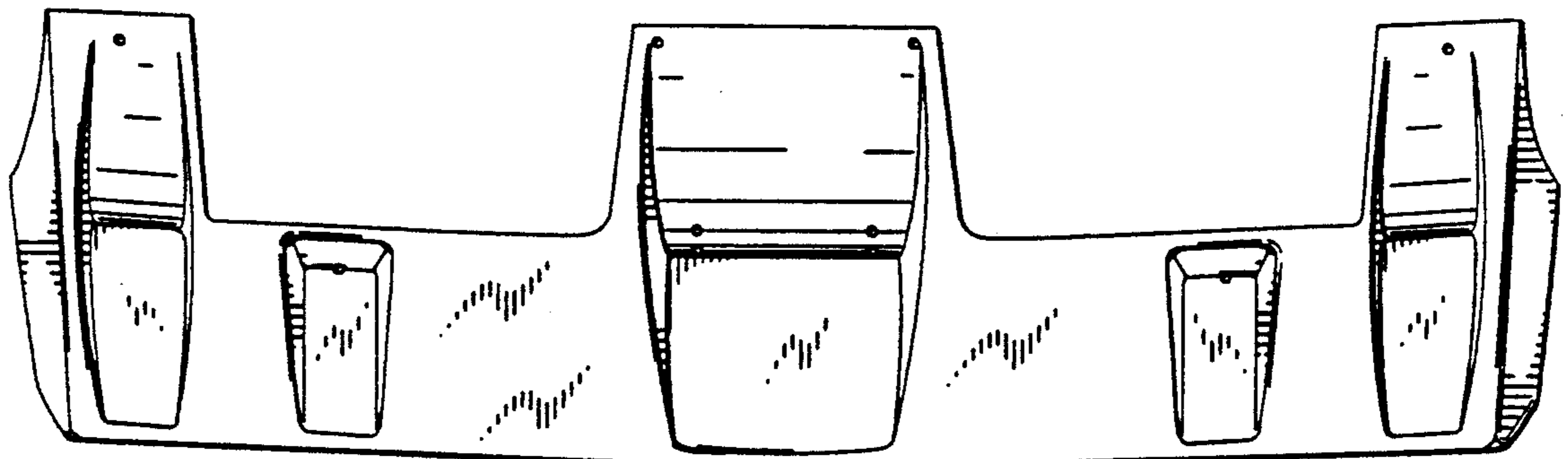
**FIG 2**



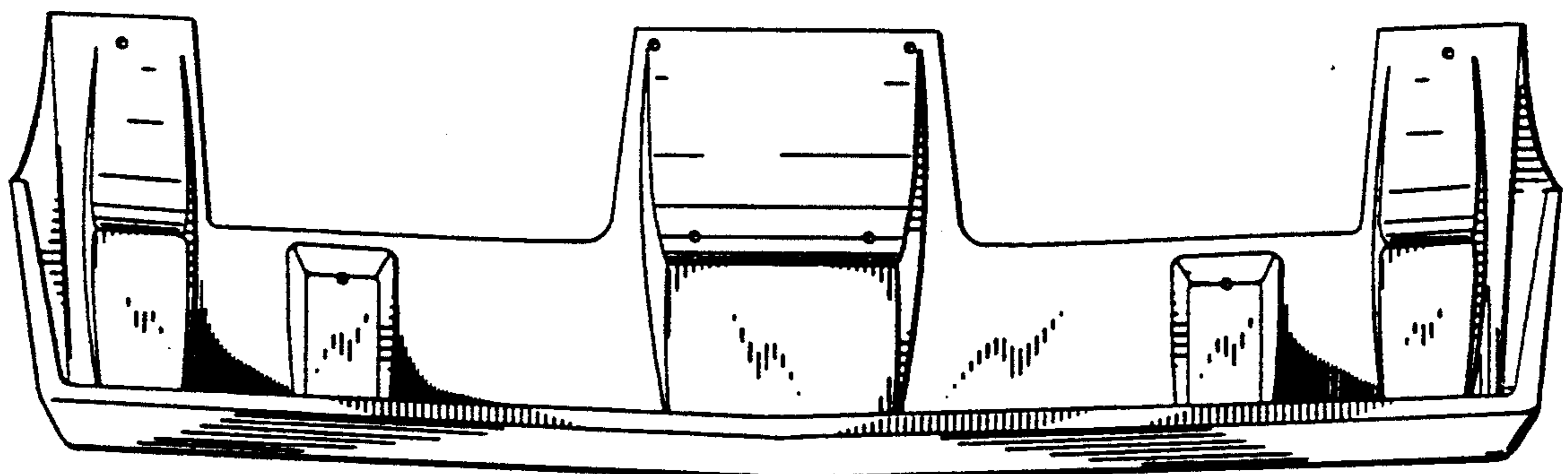
**FIG 3**



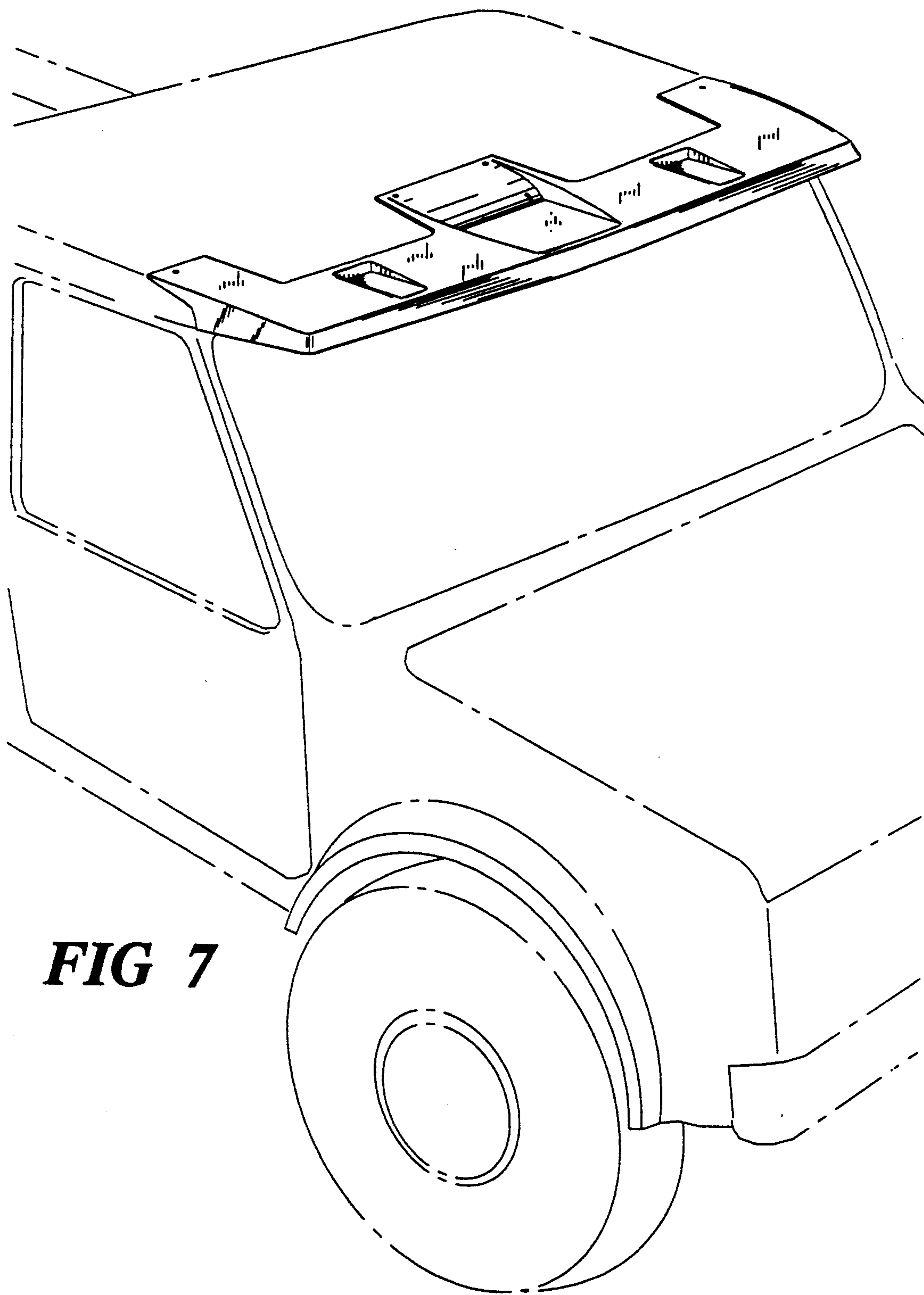
**FIG 4**



**FIG 5**



**FIG 6**



**FIG 7**



**FIG 8**

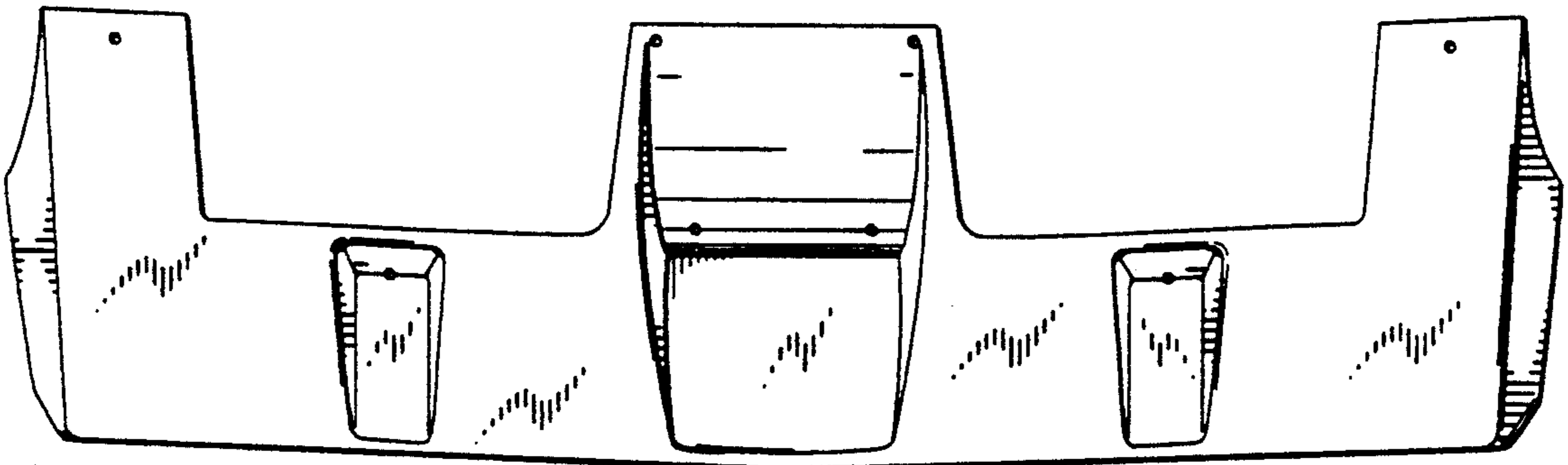




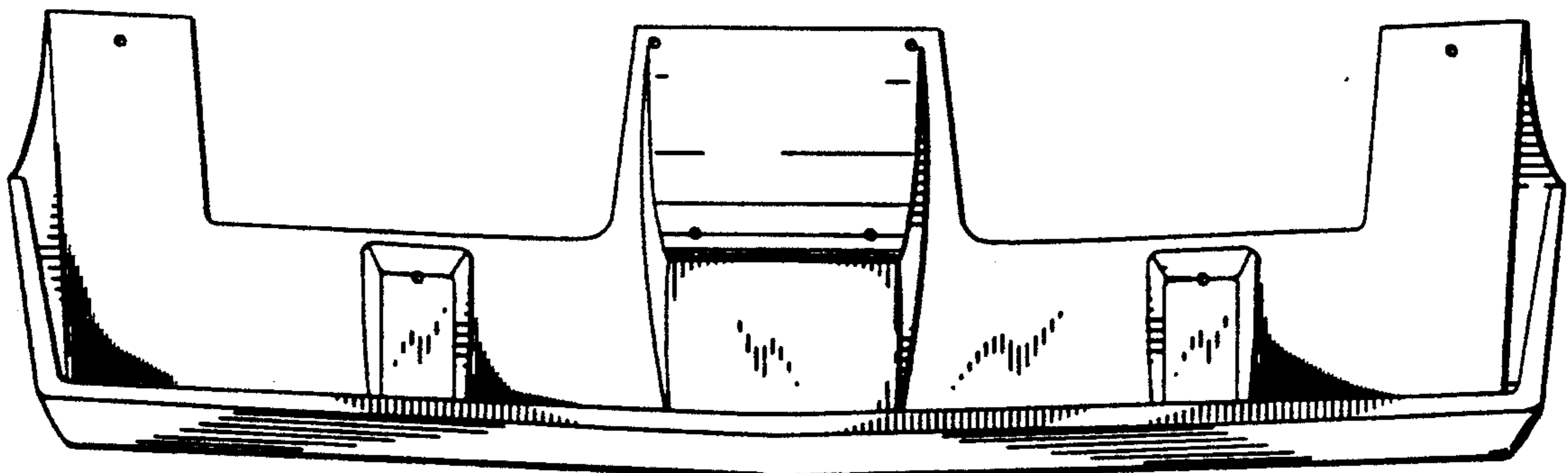
**FIG 9**



**FIG 10**



**FIG 11**



**FIG 12**