



US00D343145S

United States Patent [19]
Harbury

[11] **Patent Number: Des. 343,145**

[45] **Date of Patent: ** Jan. 11, 1994**

[54] **AUTOMOBILE**

[75] **Inventor: Peter Harbury, Gothenburg, Sweden**

[73] **Assignee: Aktiebolaget Volvo, Gothenburg, Sweden**

[**] **Term: 14 Years**

[21] **Appl. No.: 3,316**

[22] **Filed: Dec. 16, 1992**

[30] **Foreign Application Priority Data**

Sep. 25, 1992 [SE] Sweden 921961

[52] **U.S. Cl. D12/92**

[58] **Field of Search 296/185; D12/91, 92**

[56] **References Cited**

U.S. PATENT DOCUMENTS

D. 317,888 7/1991 Koch D12/92

D. 327,239 6/1992 Ui et al. D12/92
D. 334,907 4/1993 Boyer D12/92

OTHER PUBLICATIONS

1992 Buick Brochure, ©1991, p. 22, Buick LeSabre.

Primary Examiner—James M. Gandy
Attorney, Agent, or Firm—Young & Thompson

[57] **CLAIM**

The ornamental design for an automobile, as shown and described.

DESCRIPTION

FIG. 1 is a front elevational view of an automobile, showing my new design;
FIG. 2 is a side and front perspective view thereof;
FIG. 3 is a side elevational view thereof, the opposite side thereof is identical thereto;
FIG. 4 is a top plan view thereof; and,
FIG. 5 is a rear elevational view thereof.

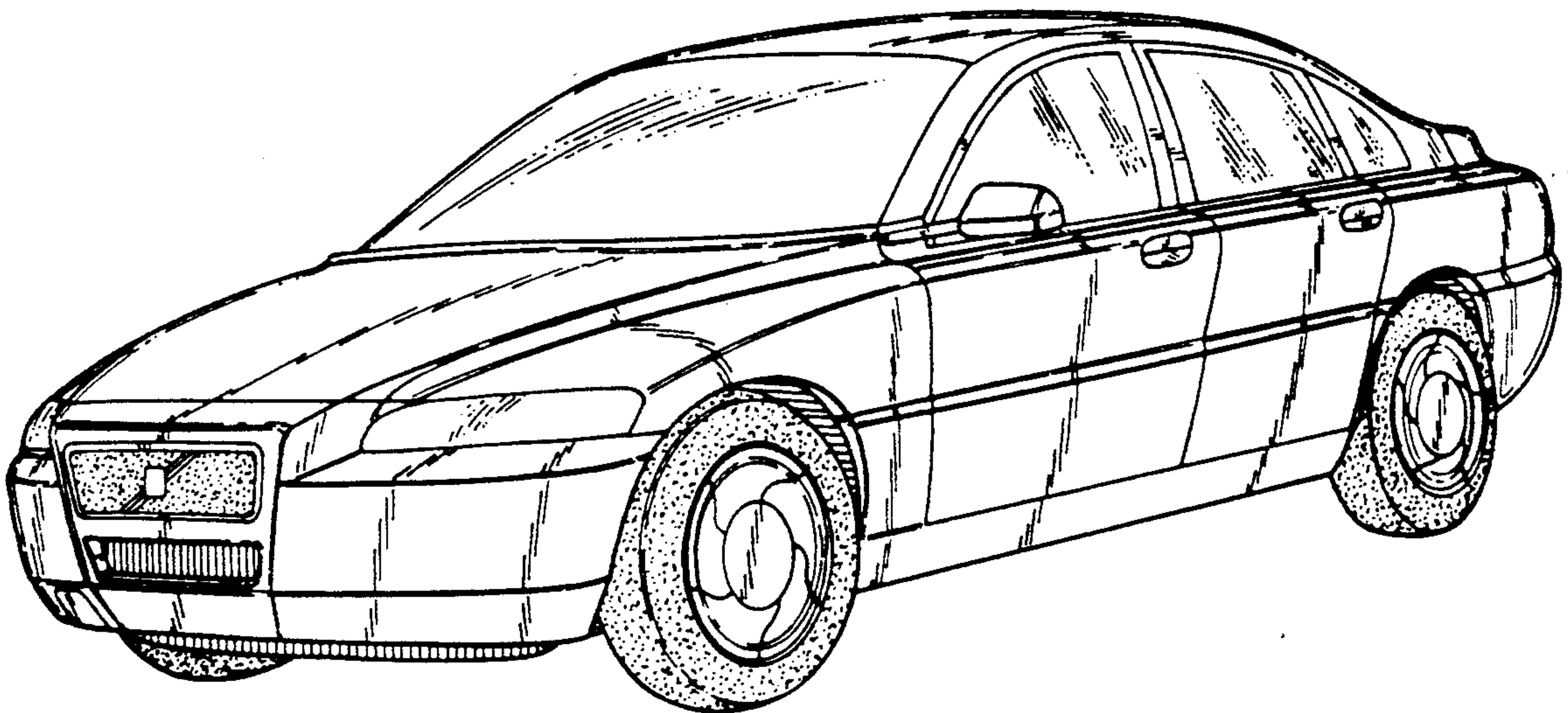

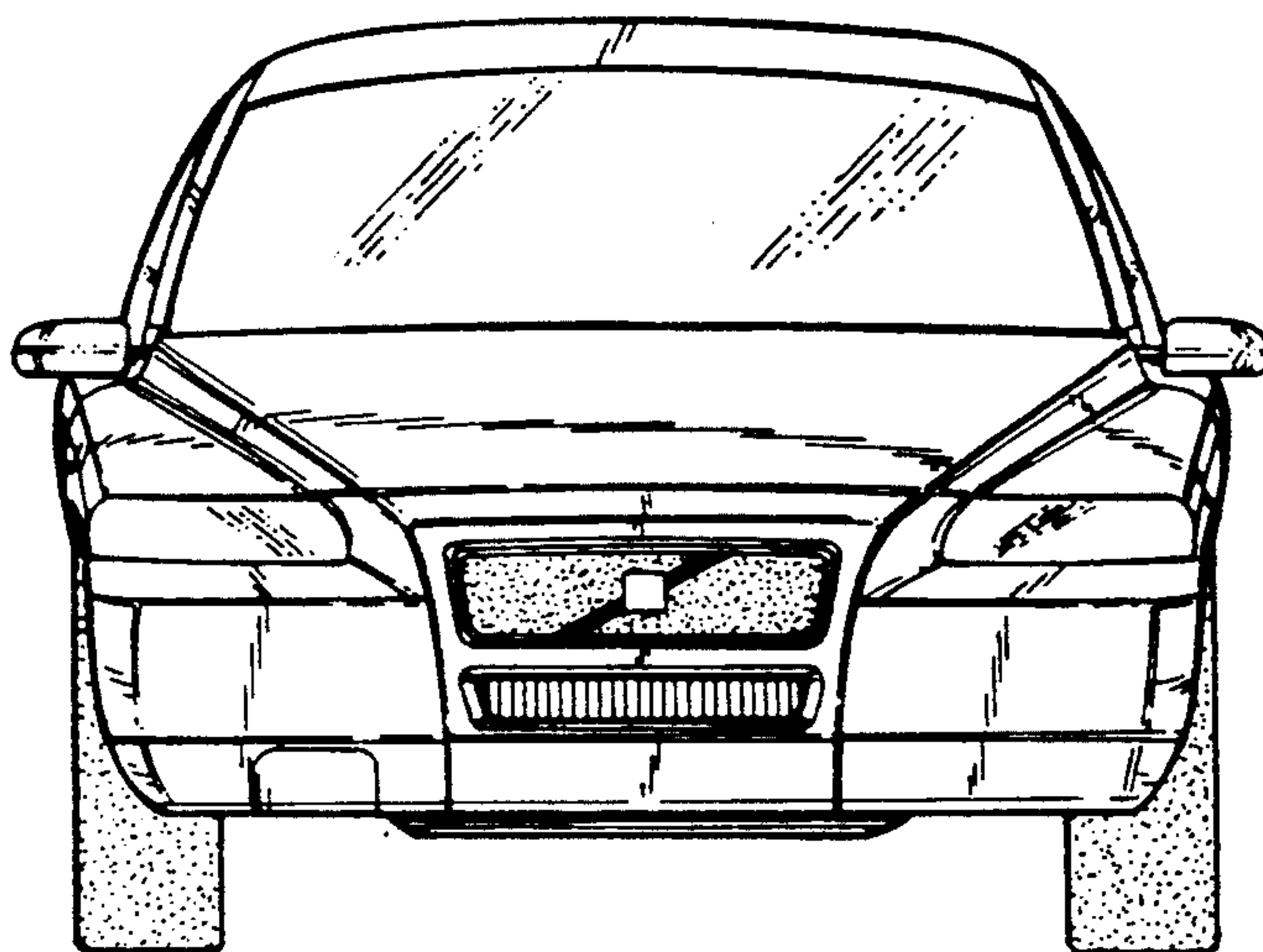

FIG. 1

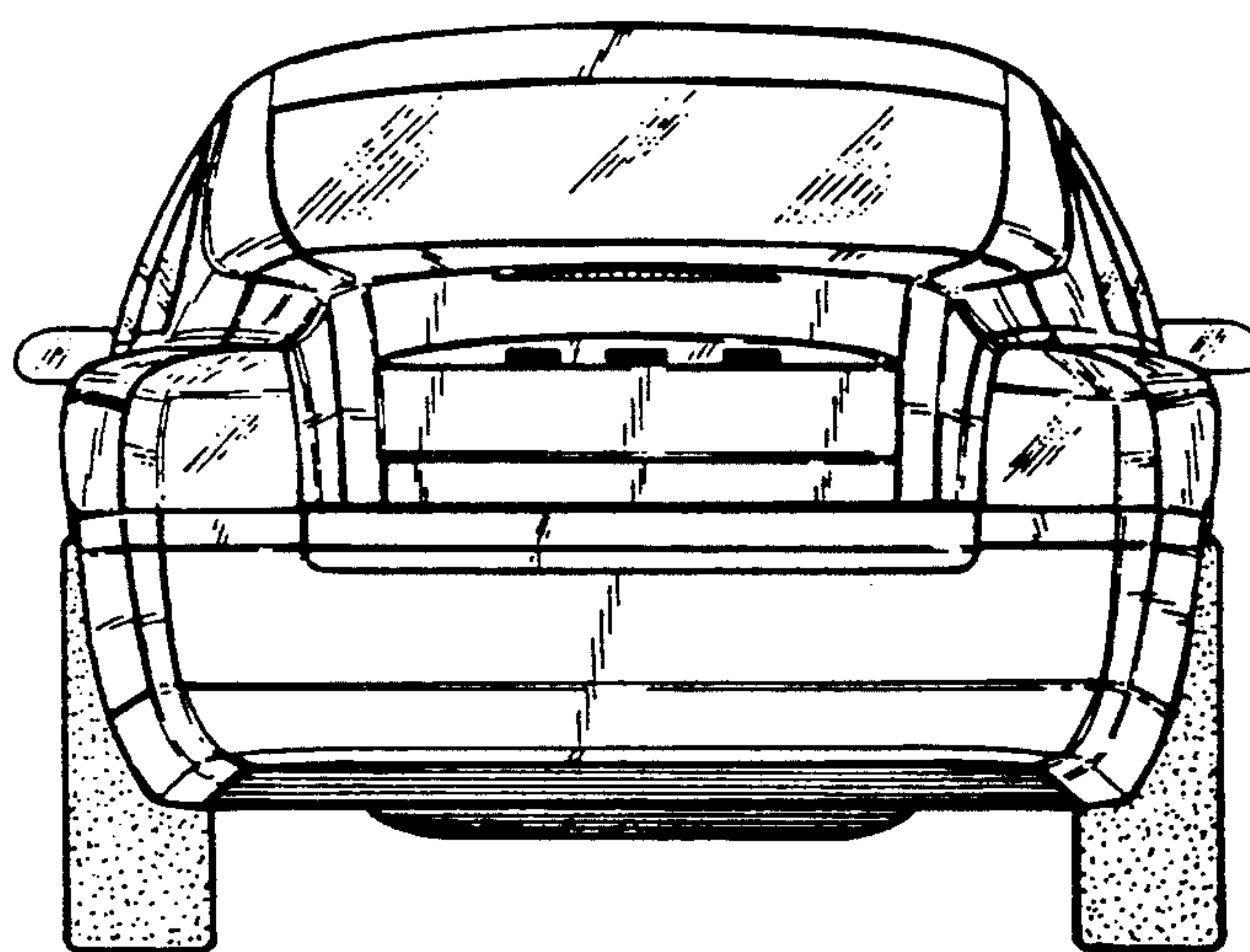

FIG. 5

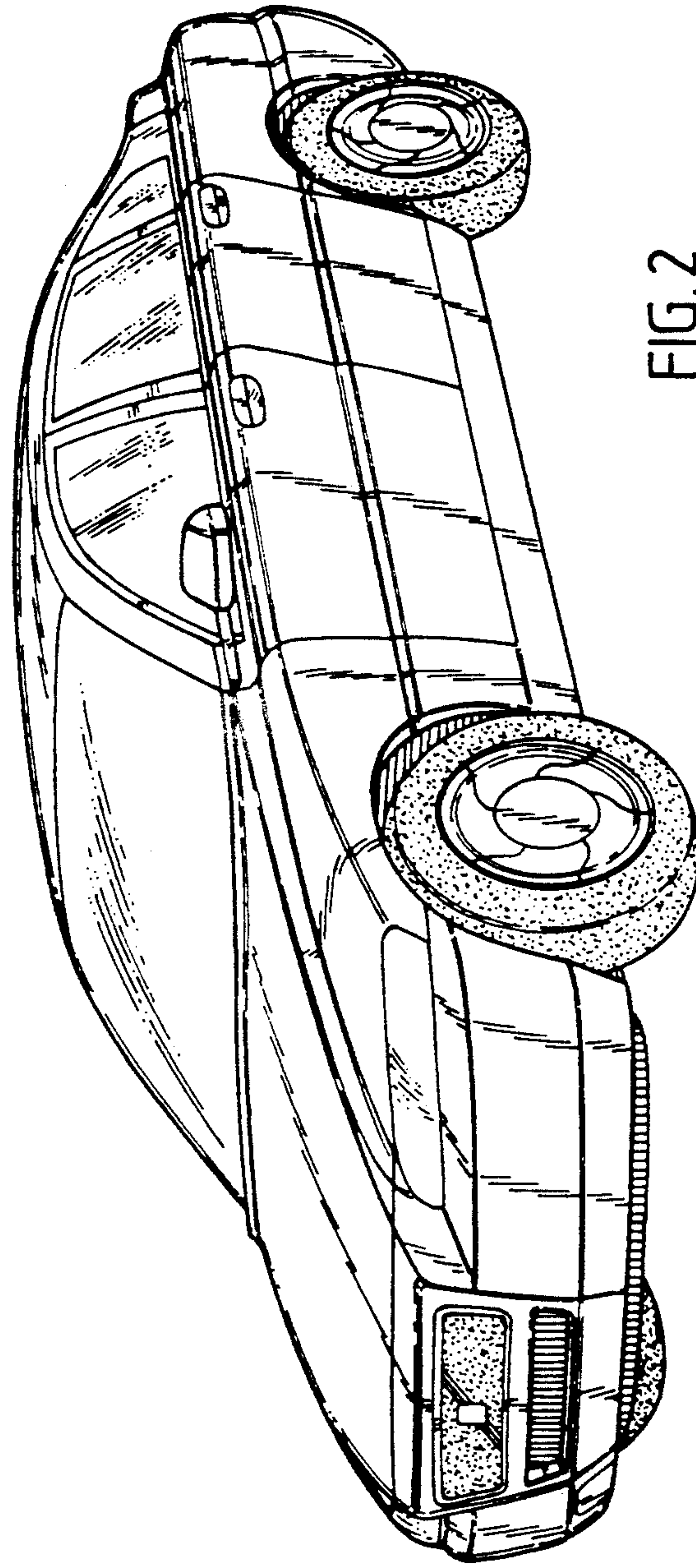

FIG. 2

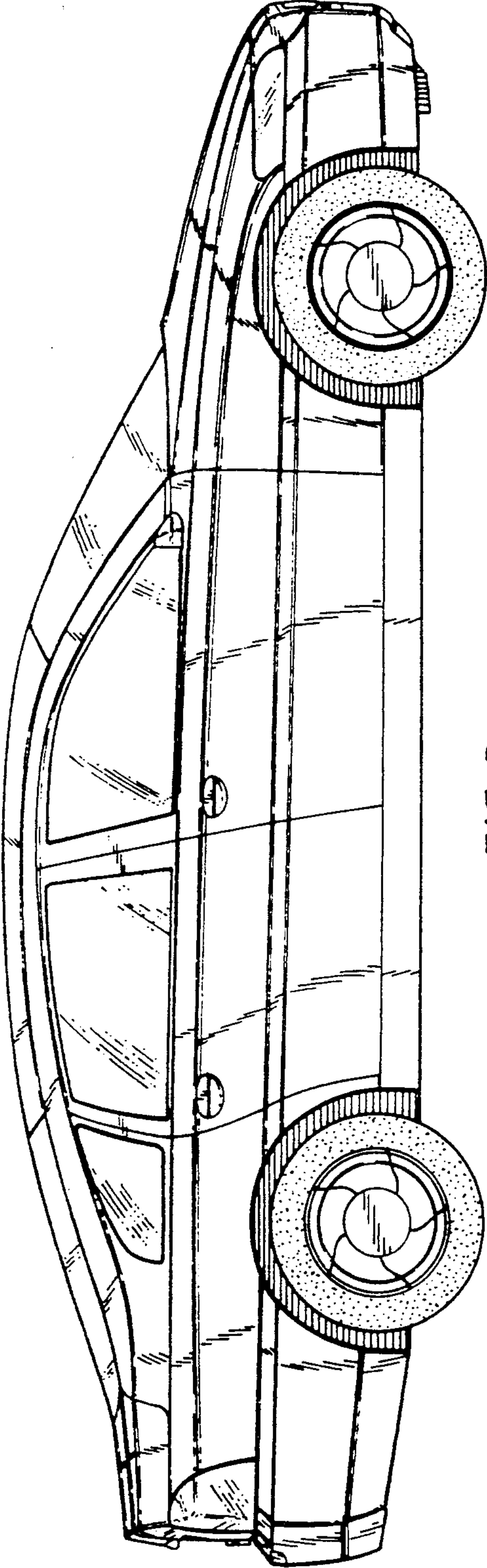

FIG. 3

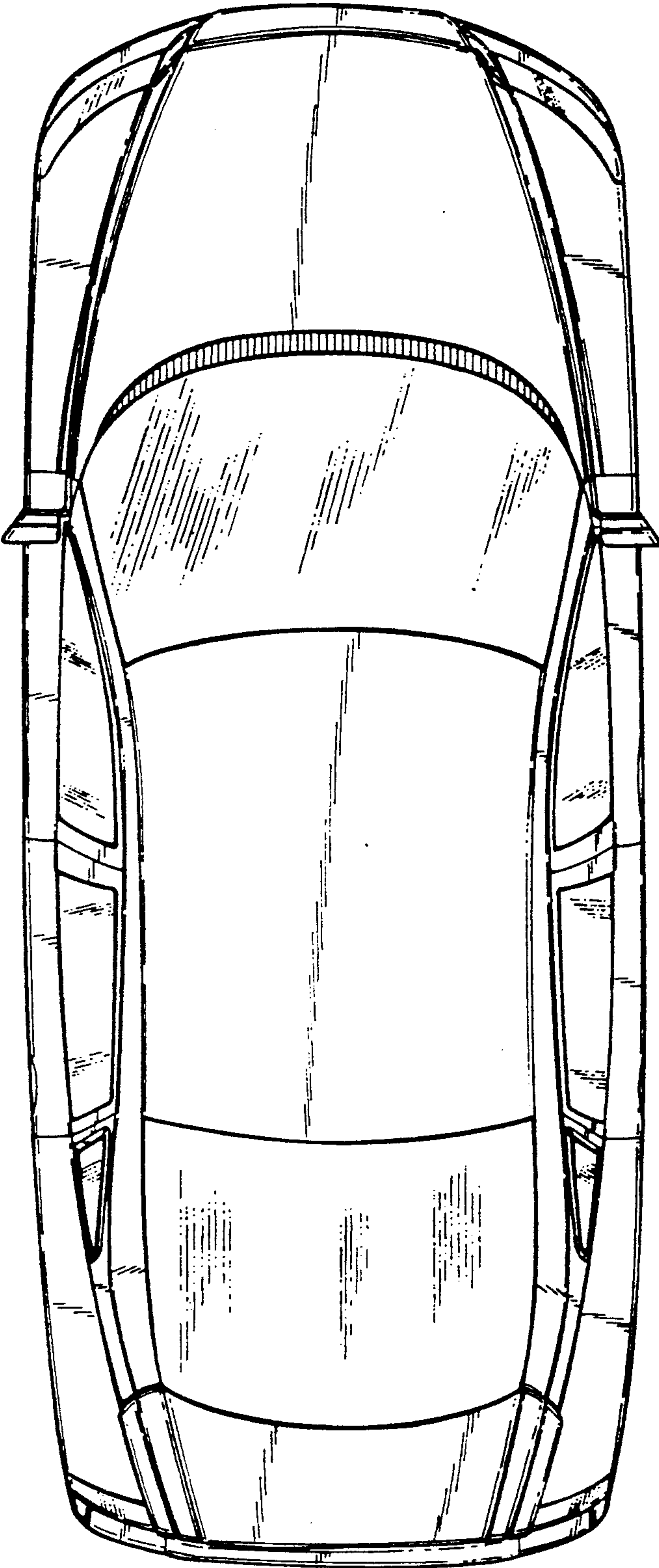

FIG. 4