



US00D343032S

United States Patent [19]

[11] Patent Number: **Des. 343,032**

Carrero

[45] Date of Patent: **** Jan. 4, 1994**

[54] **DOG TRANSPORT SAFETY RIG FOR PICKUP TRUCKS**

2326831 4/1977 France 119/109
1395255 5/1975 United Kingdom 119/96
2039705 8/1980 United Kingdom 119/109

[76] Inventor: **Alfred V. Carrero, P.O. Box 165, Lacochee, Fla. 33537**

Primary Examiner—A. Hugo Word
Assistant Examiner—Cathy Anne MacCormac
Attorney, Agent, or Firm—Leon Gilden

[**] Term: **14 Years**

[21] Appl. No.: **596,972**

[57] **CLAIM**

[22] Filed: **Oct. 12, 1990**

The ornamental design for a dog transport safety rig for pickup trucks, as shown and described.

[52] U.S. Cl. **D30/151**

[58] Field of Search 119/120, 109, 96;
D30/151-153

DESCRIPTION

[56] **References Cited**

U.S. PATENT DOCUMENTS

225,404 3/1980 Maxey 119/120
D. 244,869 6/1977 Manley et al. D30/153
3,491,726 1/1970 Partin 119/96
4,252,084 2/1981 Willow 119/96
4,791,886 12/1988 Anderson 119/120
4,827,876 5/1989 Kreckelberg 119/109
4,834,027 5/1989 Meyer 119/120
4,899,694 2/1990 Belluomini 119/109
4,947,801 8/1990 Glass 119/120
4,958,597 9/1990 Mildner 119/96

FIG. 1 is a right end elevational view of a dog transport safety rig for pickup trucks showing my new design; FIG. 2 is a left end elevational view thereof; FIG. 3 is a side elevational view thereof; FIG. 4 is another side elevational view thereof; FIG. 5 is a third side elevational view thereof; FIG. 6 is a fourth side elevational view thereof; FIG. 7 is an enlarged, fragmentary view thereof taken near the left side of FIG. 3; FIG. 8 is an enlarged fragmentary view thereof taken in the middle of FIG. 3; FIG. 9 is an enlarged, fragmentary view thereof taken at the right side of FIG. 3; and, FIG. 10 is a perspective view thereof, the broken lines are for purposes of illustration only and form no part of the claimed design.

FOREIGN PATENT DOCUMENTS

1121401 1/1962 Fed. Rep. of Germany 119/109

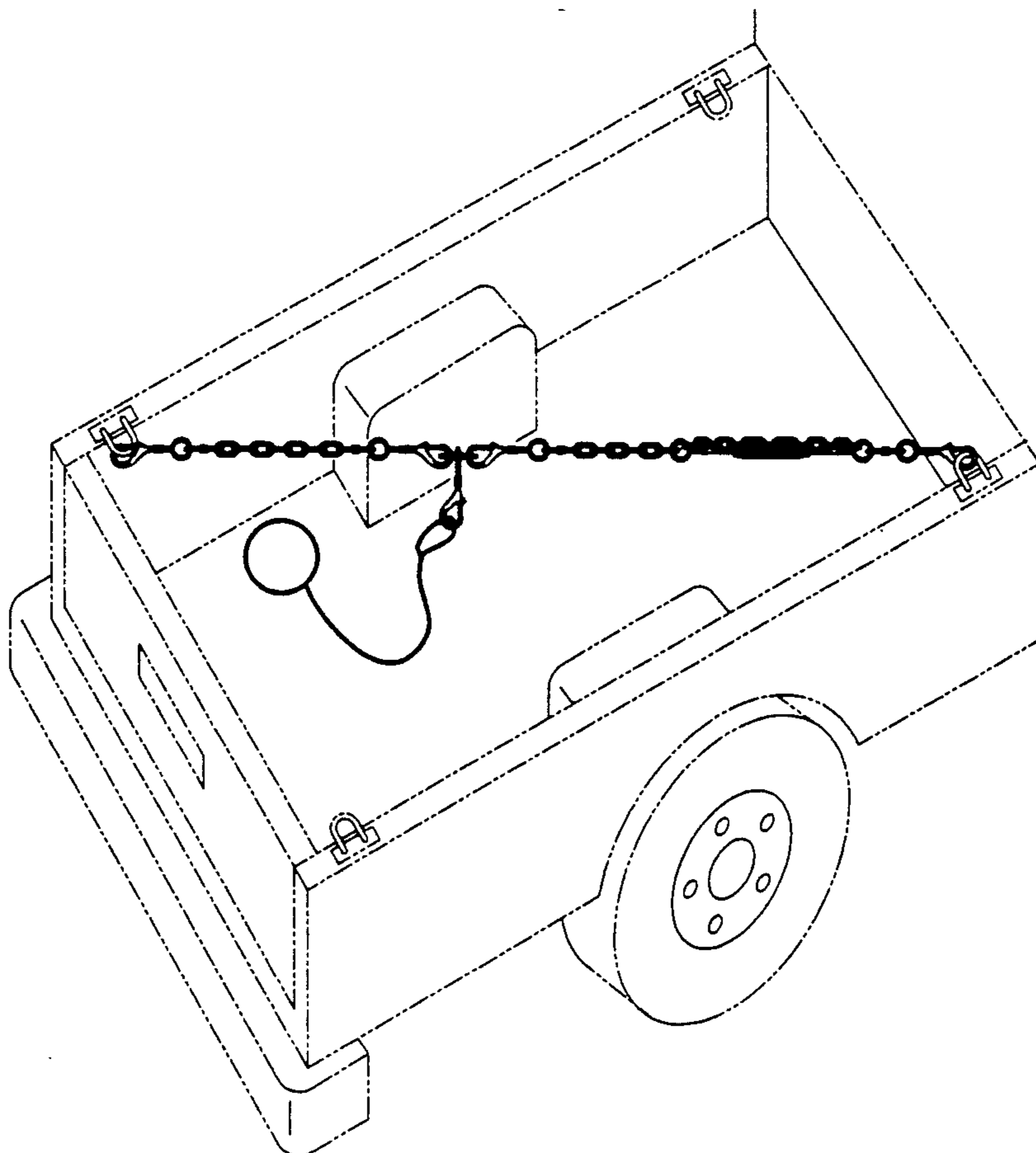

FIG. 1

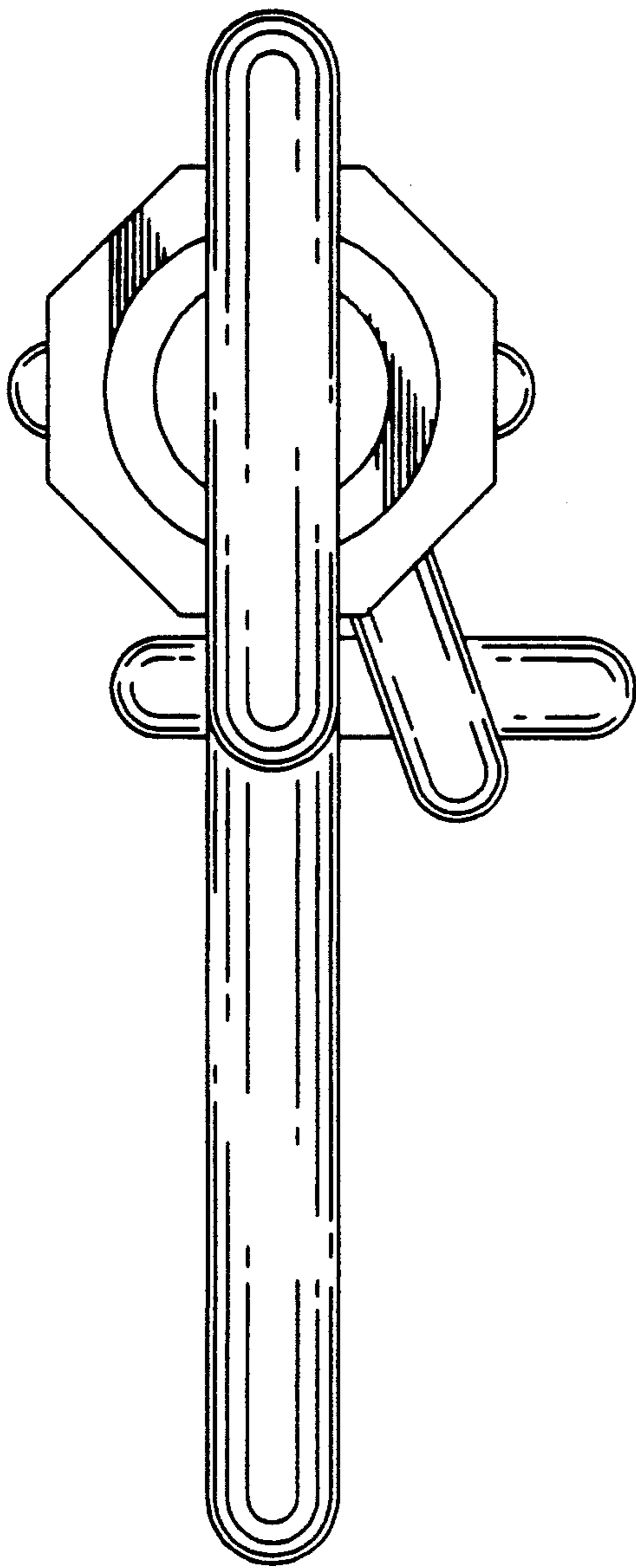
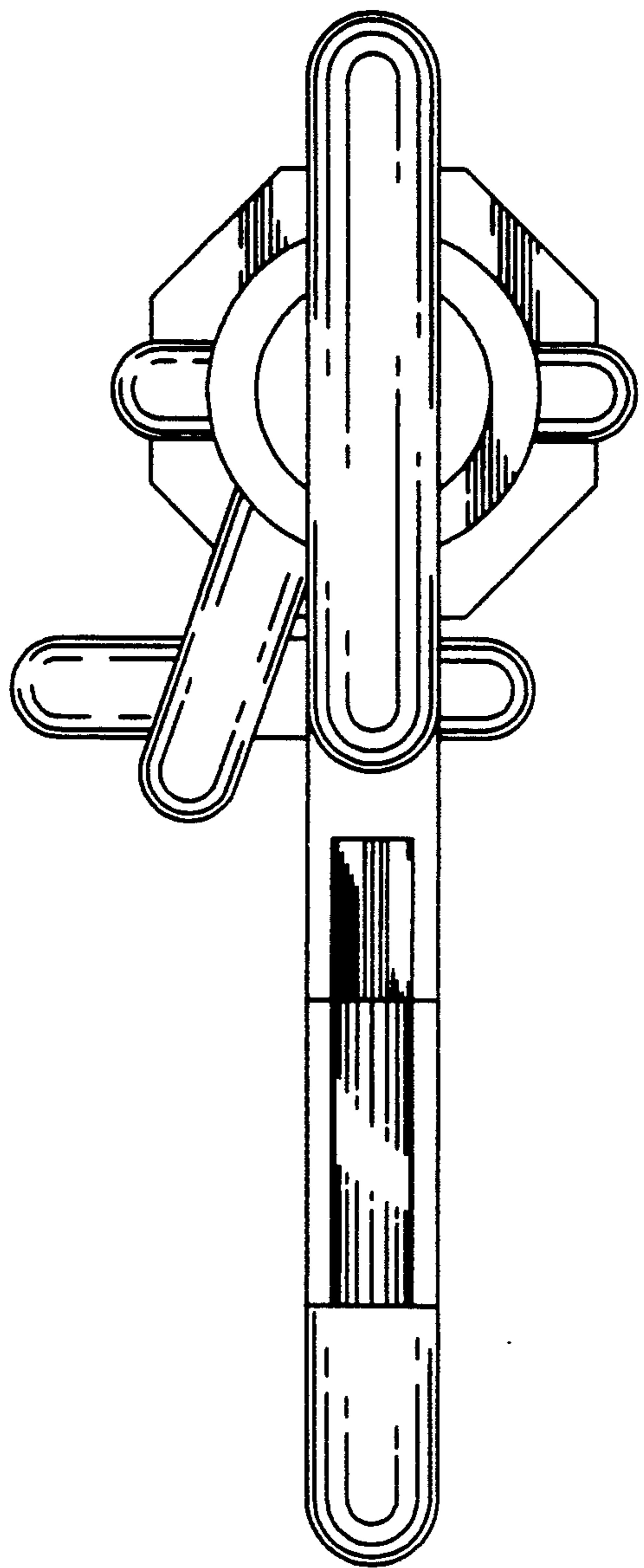

FIG. 2



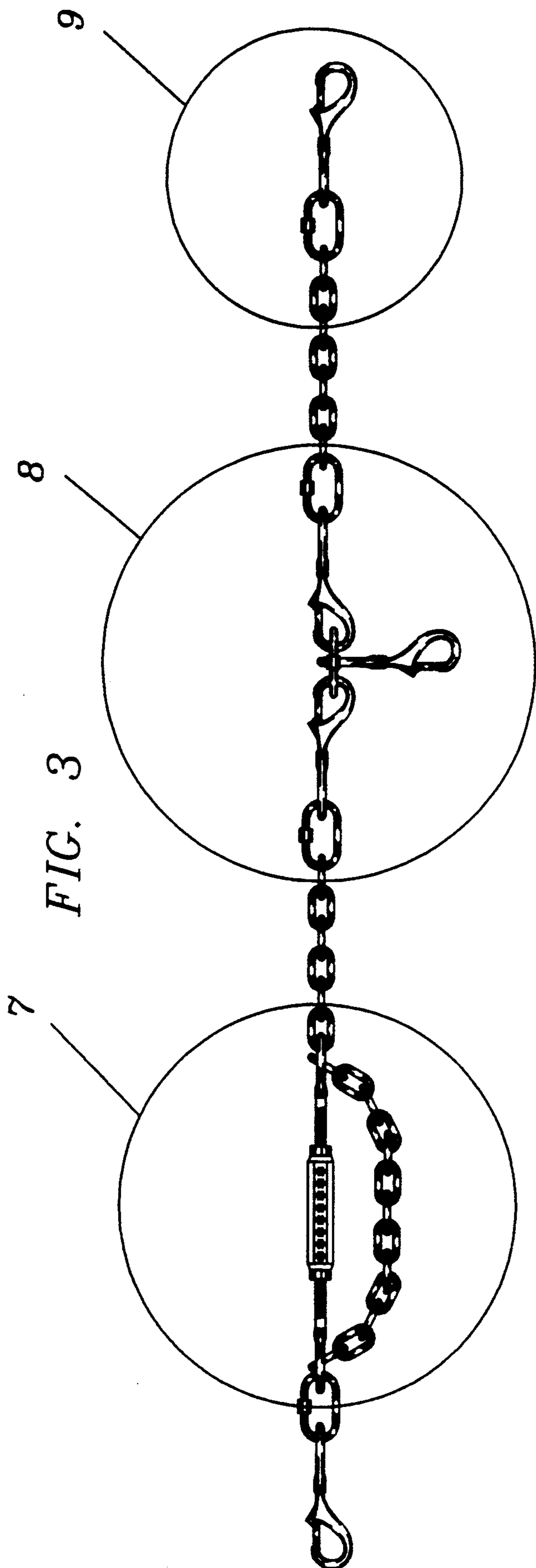

FIG. 4

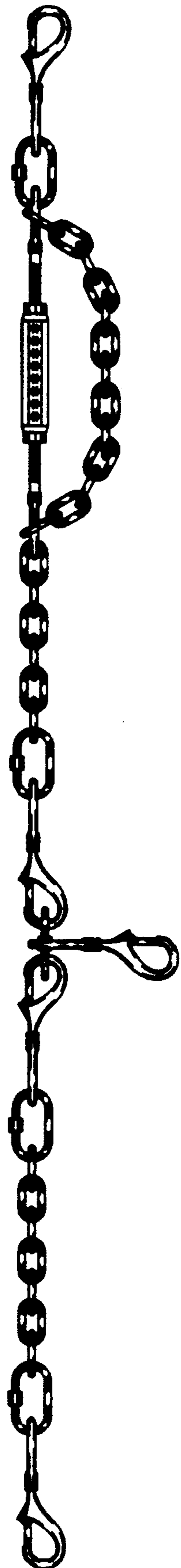

FIG. 5



FIG. 6



FIG. 7

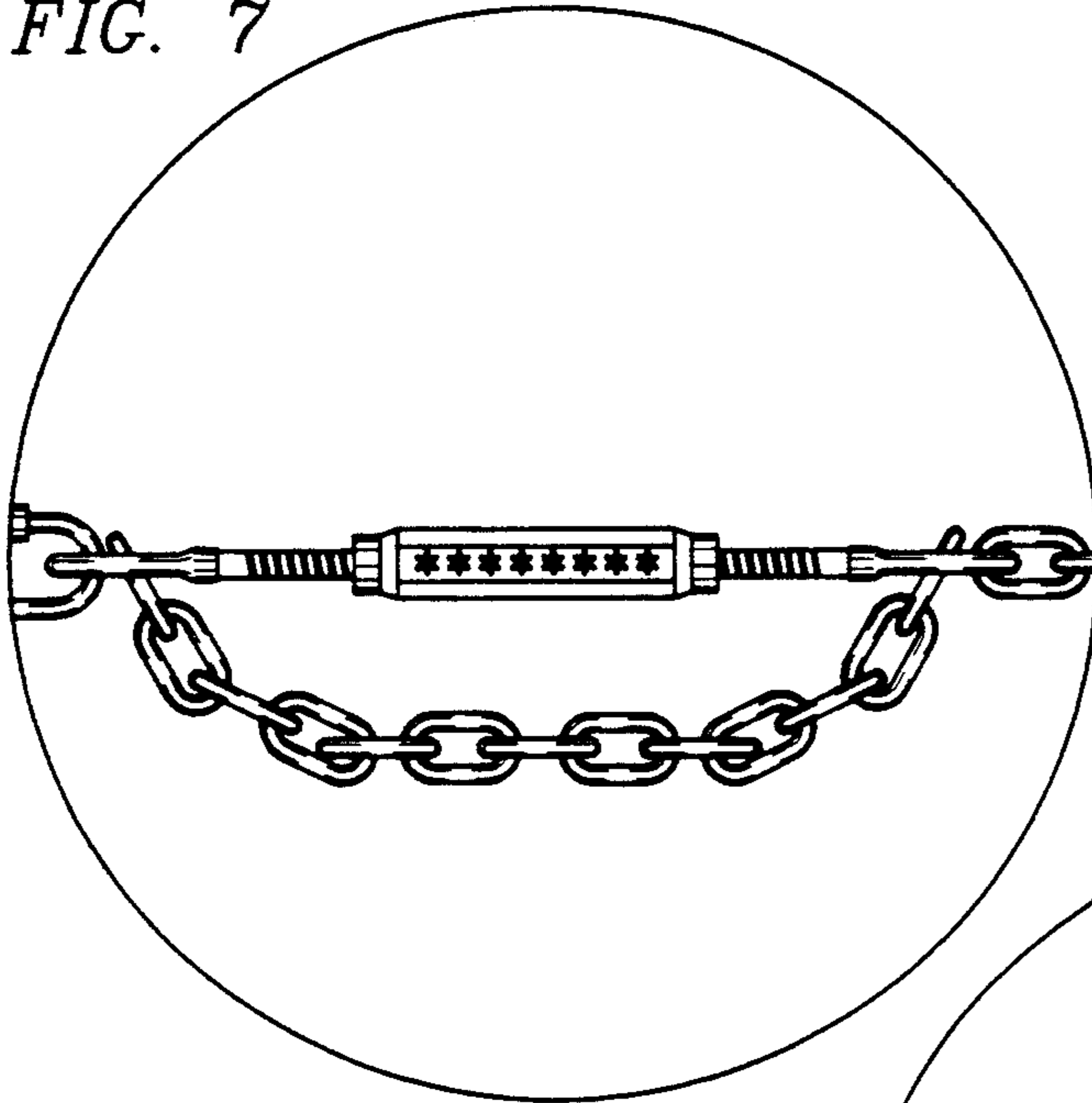

FIG. 8

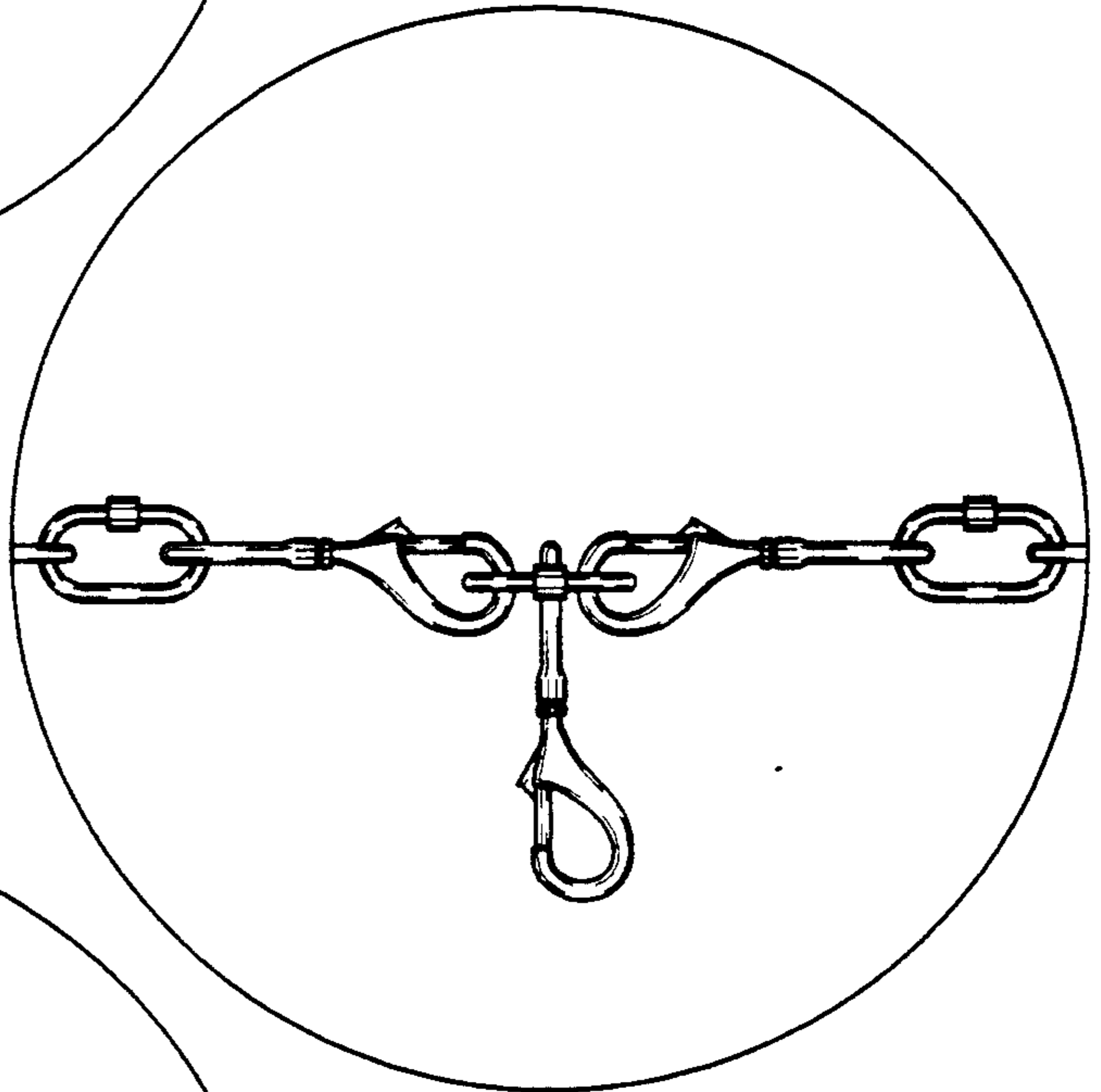

FIG. 9

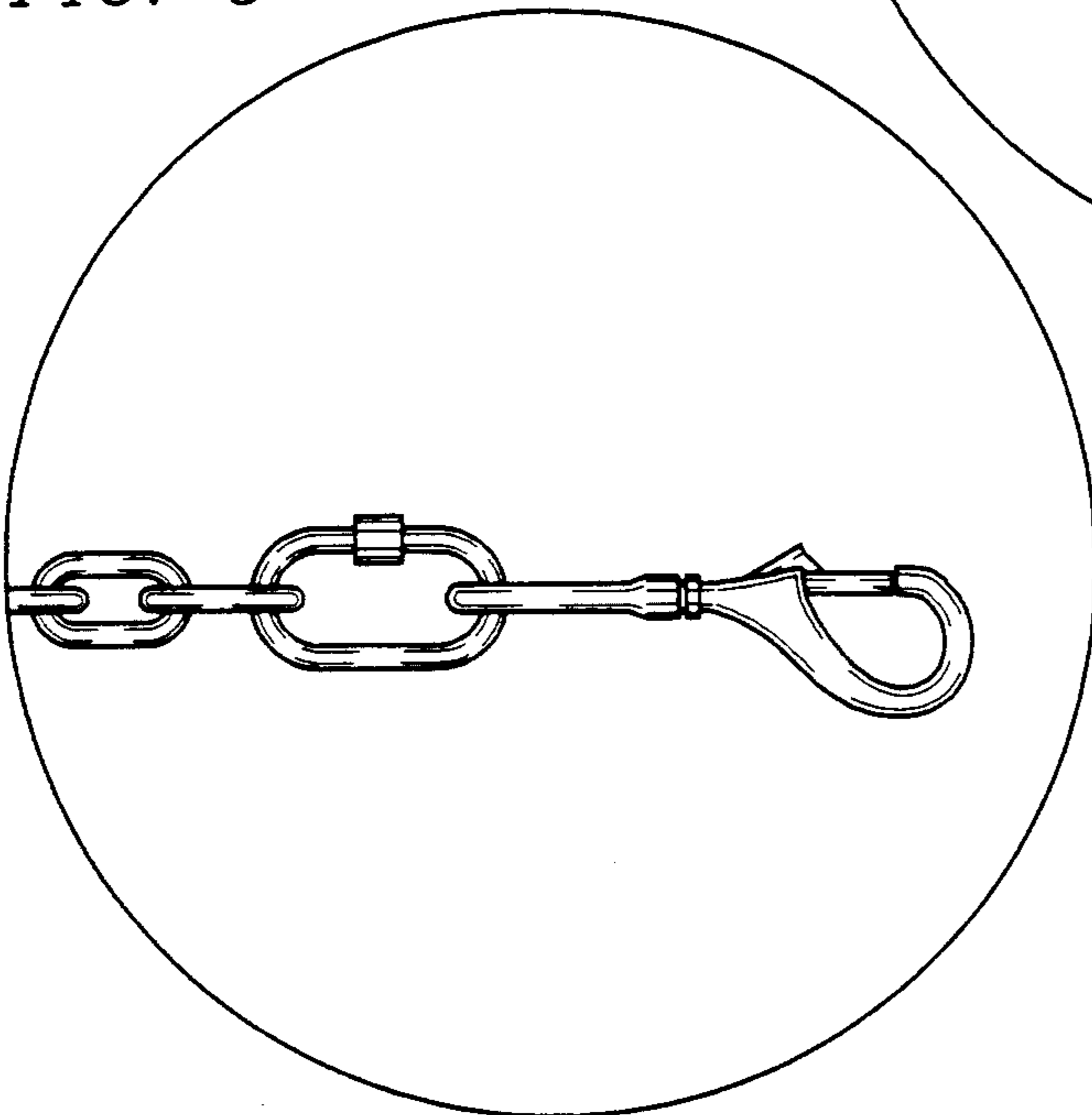

FIG. 10

