



US00D342933S

United States Patent [19]

[11] Patent Number: **Des. 342,933**

Hopper et al.

[45] Date of Patent: **** Jan. 4, 1994**

[54] **BOAT**

[75] Inventors: **Randy W. Hopper**, Flippin; **Dale H. Jensen**, Everton; **Kenneth P. Poley**, Yellville, all of Ark.

[73] Assignee: **Wood Manufacturing Co.**, Flippin, Ark.

[**] Term: **14 Years**

[21] Appl. No.: **897,550**

[22] Filed: **Jun. 12, 1992**

[52] U.S. Cl. **D12/314; D12/313**

[58] Field of Search 114/271, 56, 57, 290, 114/291; D12/300, 311, 310, 312, 313, 314, 315

[56] **References Cited**

U.S. PATENT DOCUMENTS

D. 252,507	7/1979	Wood	D12/311
D. 291,685	9/1987	Wood et al.	D12/314
D. 326,841	6/1992	Hopper et al.	D12/311

Primary Examiner—Kay H. Chin
Attorney, Agent, or Firm—Wayne B. Stone, Jr.

[57] **CLAIM**

The ornamental design for a boat, as shown and described.

DESCRIPTION

FIG. 1 is a perspective view of a boat showing a first form of our new design;
 FIG. 2 is a top plan view thereof;
 FIG. 3 is a front elevational view thereof;
 FIG. 4 is a rear elevational view thereof;
 FIG. 5 is a perspective view of a second form of our boat design;
 FIG. 6 is a top plan view of the boat of FIG. 5;
 FIG. 7 is a front elevational view of the boat of FIG. 5;
 FIG. 8 is a rear elevational view of the boat of FIG. 5;
 FIG. 9 is a side elevational view of the left side of the boats of FIGS. 1 and 5, the right sides being mirror images of the left sides; and,
 FIG. 10 is a bottom plan view of the boats of FIGS. 1 and 5.

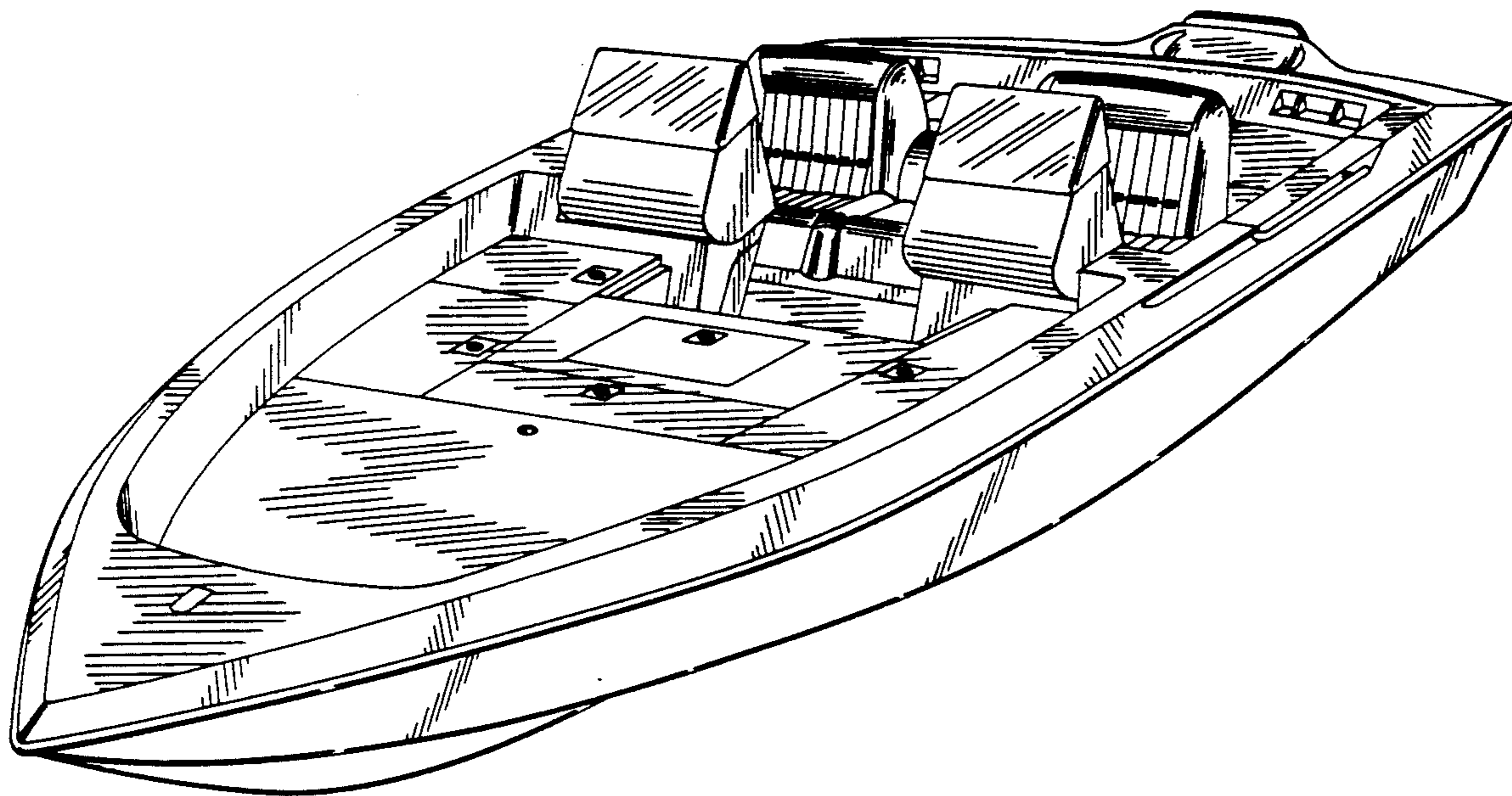

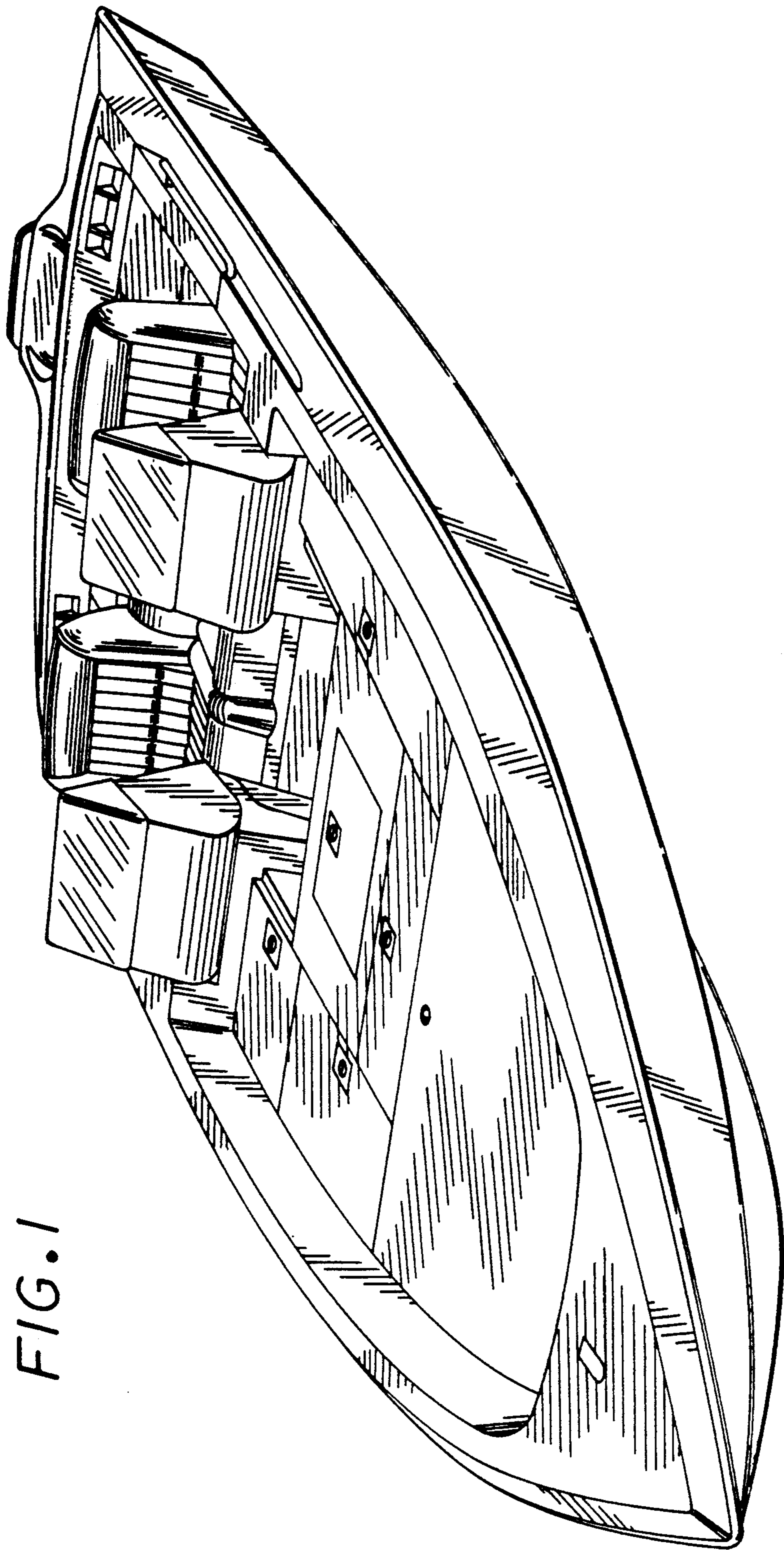

FIG. 1

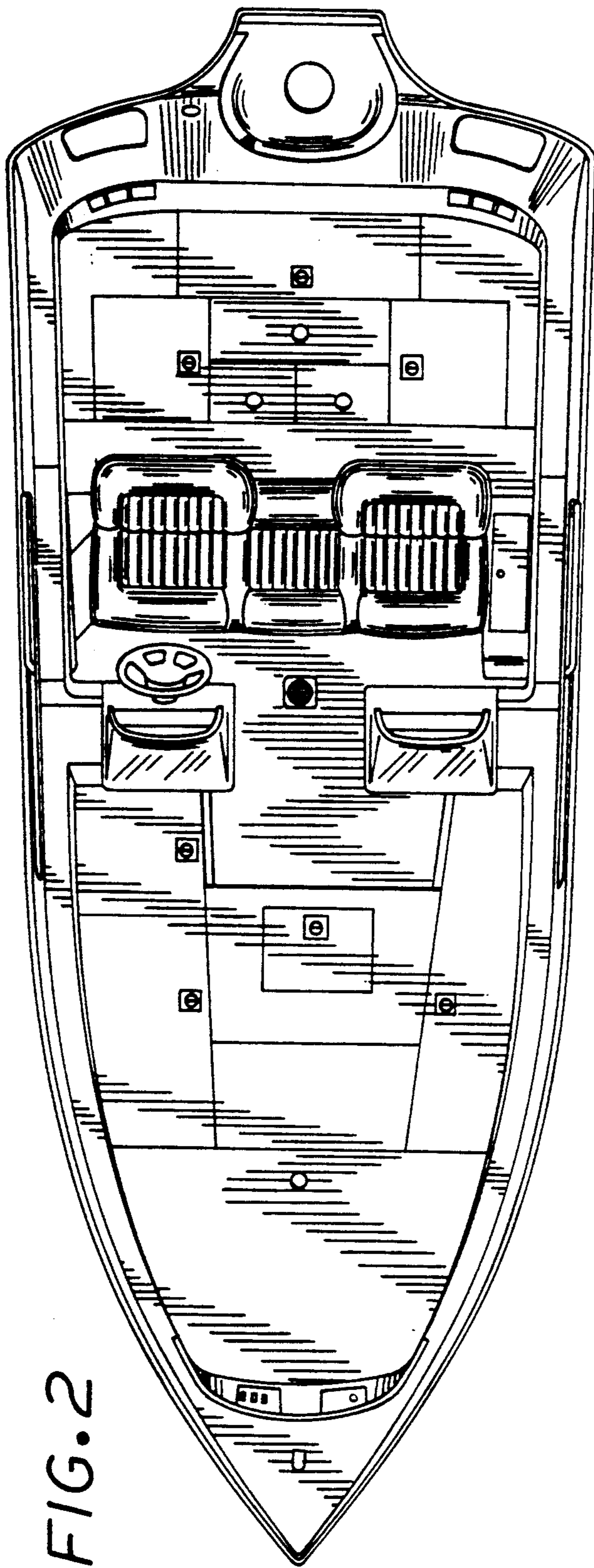

FIG. 2

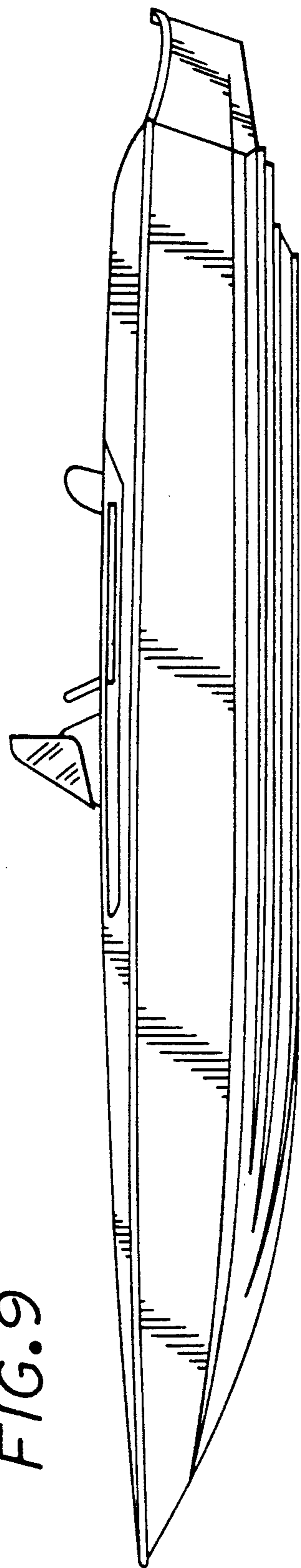

FIG. 9

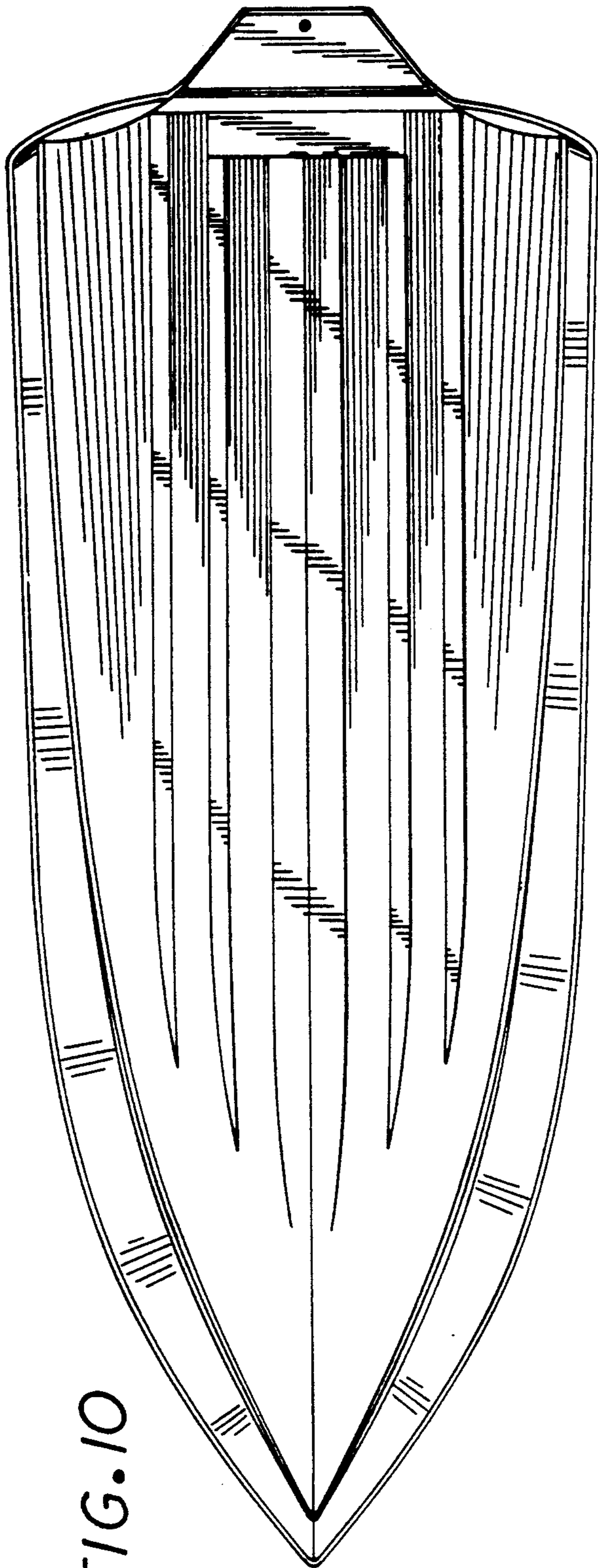

FIG. 10

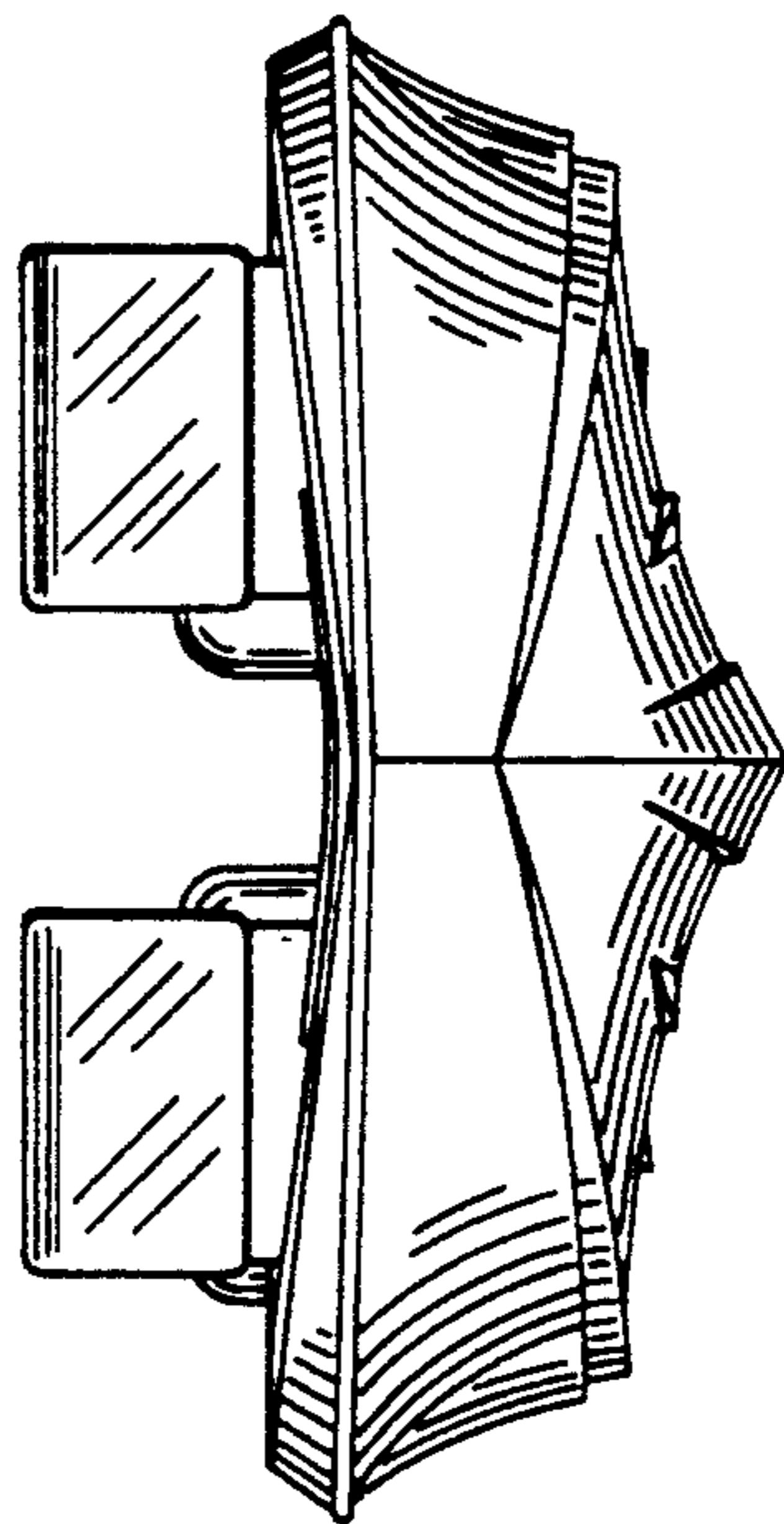

FIG. 3

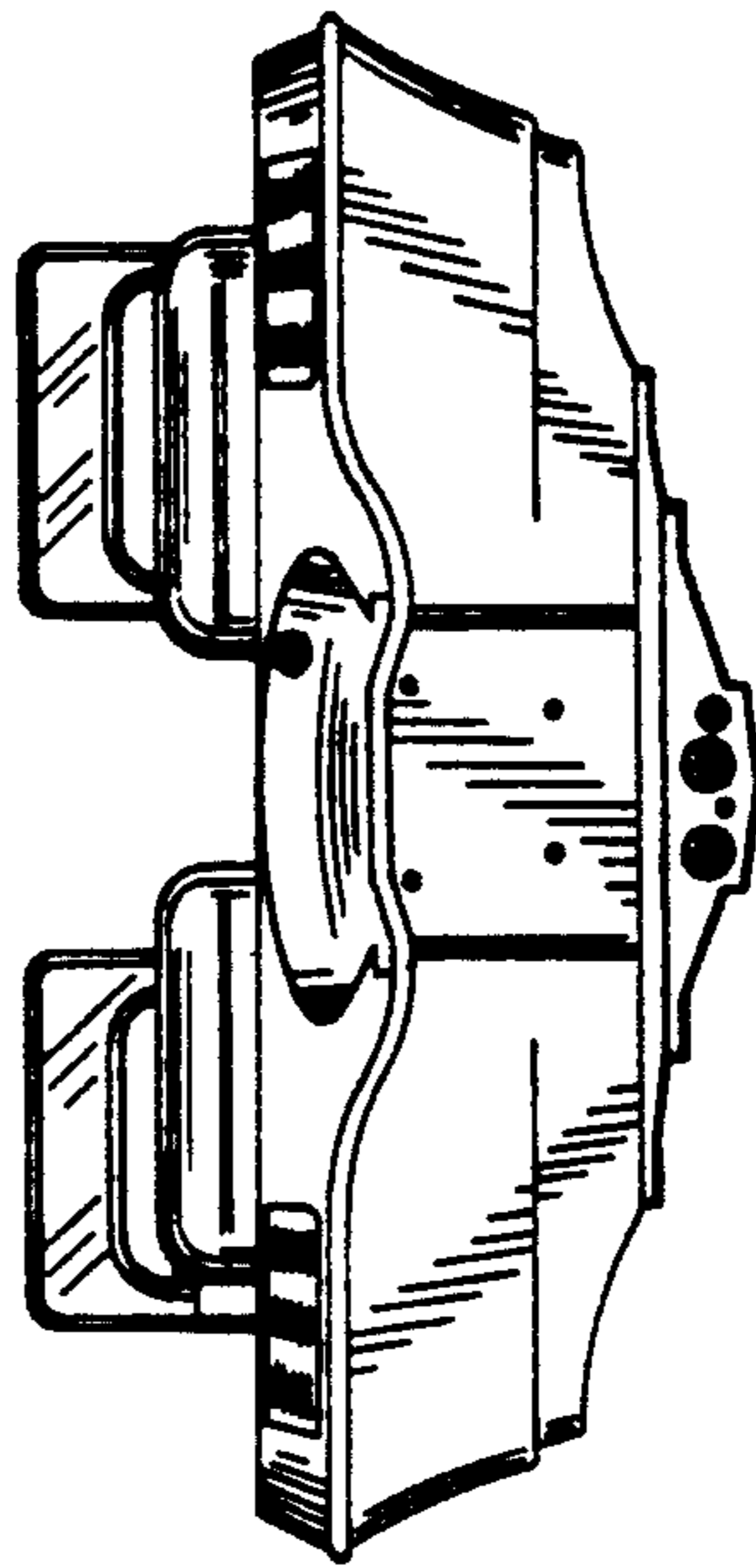

FIG. 4

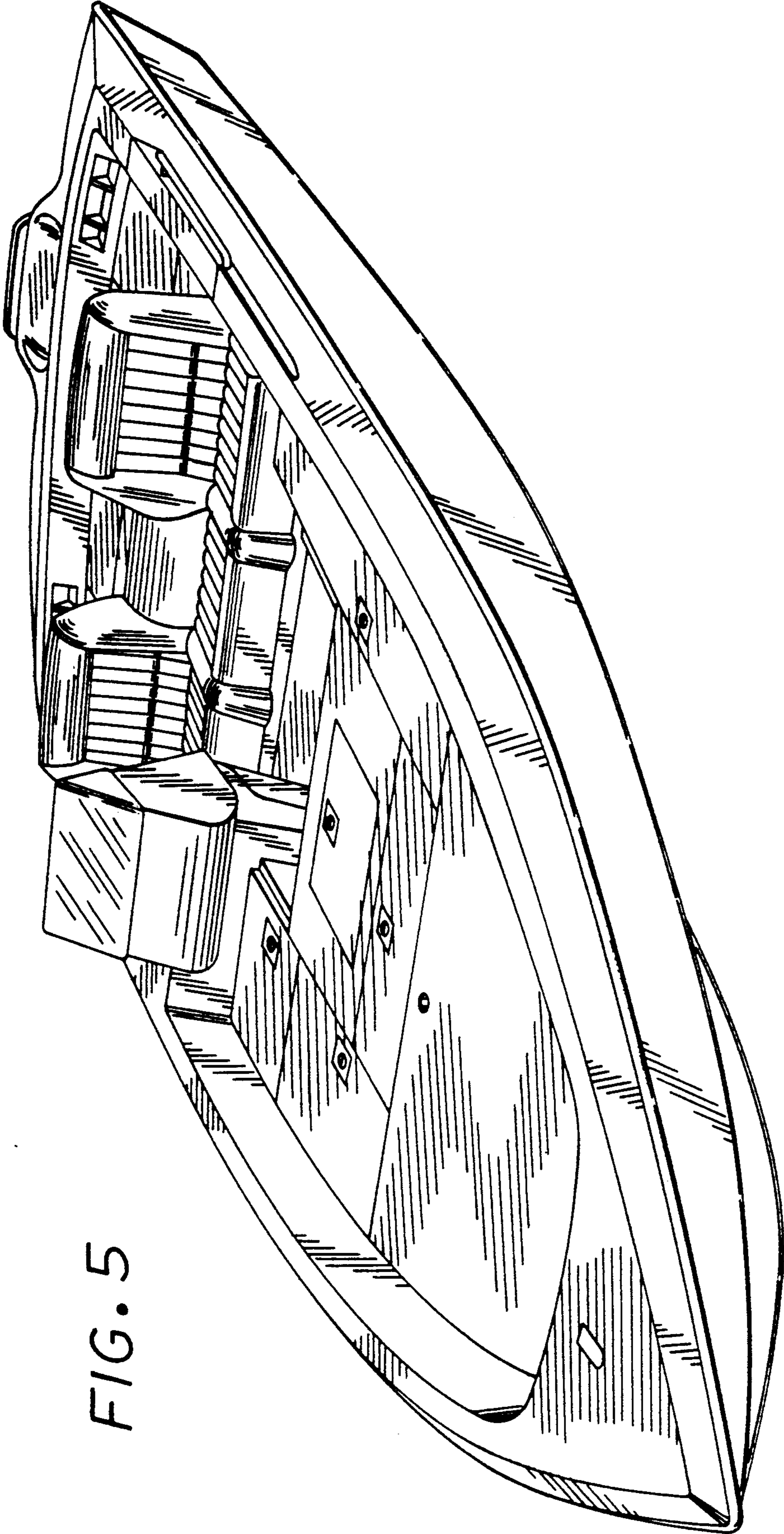

FIG. 5

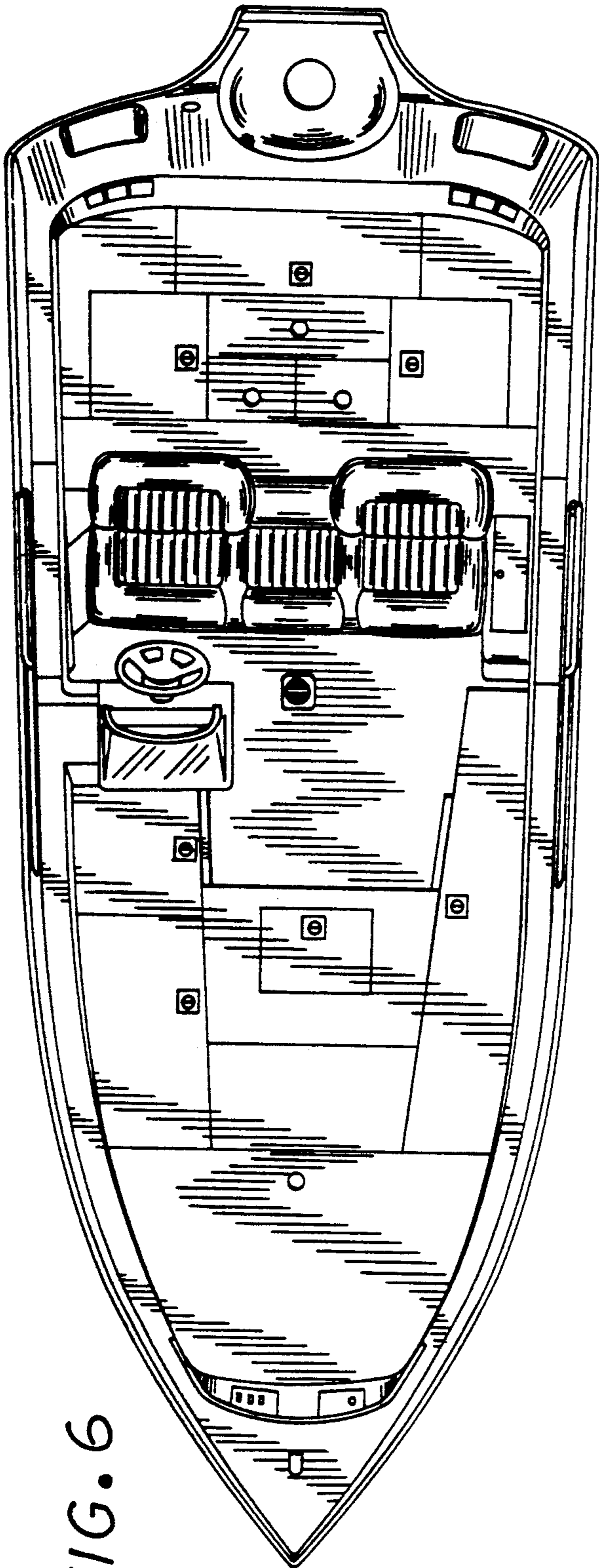

FIG. 6

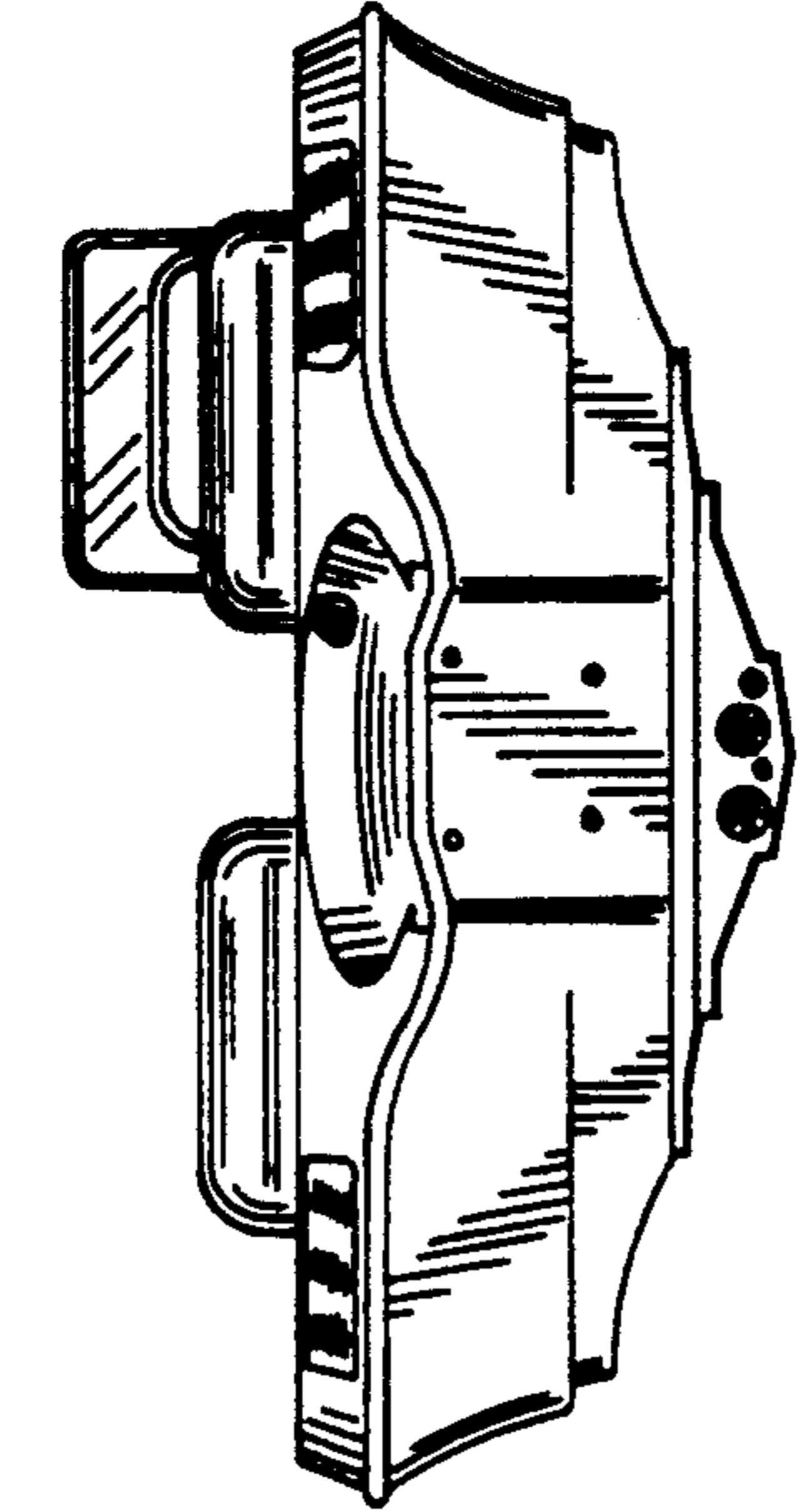

FIG. 8

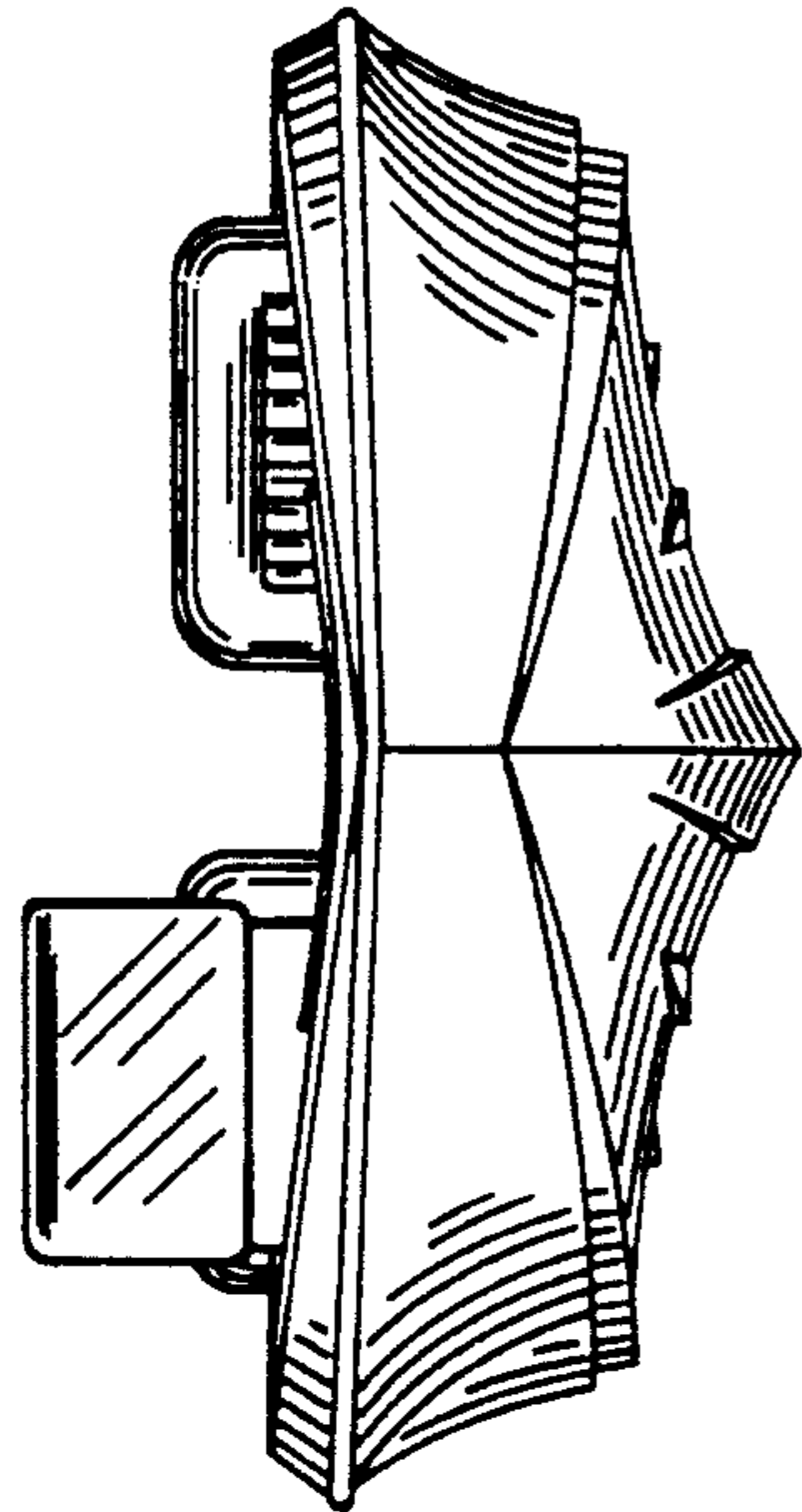

FIG. 7