



US00D342881S

United States Patent [19] Hoke

[11] Patent Number: **Des. 342,881**

[45] Date of Patent: **** Jan. 4, 1994**

[54] HOLD-DOWN CLAMP FOR WELDING

[76] Inventor: **Thomas A. Hoke**, R.D. #2, Box 606, Red Lion, Pa. 17356

[**] Term: **14 Years**

[21] Appl. No.: **913,547**

[22] Filed: **Jul. 15, 1992**

[52] U.S. Cl. **D8/72; D15/144.2; D15/140**

[58] Field of Search **D8/71, 72; 248/74.1, 248/74.2, 74.3, 74.4, 74.5; 294/81.1-81.62, D15/144, 1442.2, 14**

[56] References Cited

U.S. PATENT DOCUMENTS

D. 298,209	10/1988	Hoke	D8/72
2,846,896	8/1958	Allen	D8/72
5,045,668	9/1991	Neiheisel et al.	219/121.83
5,139,375	8/1992	Franchuk	269/100

Primary Examiner—Nelson C. Holtje
Assistant Examiner—Antoine D. Davis
Attorney, Agent, or Firm—Charles J. Long

[57] CLAIM

The ornamental design for a hold-down clamp for welding, as shown and described.

DESCRIPTION

FIG. 1 is a front elevational view of a hold-down clamp for welding showing one embodiment of my new design;

FIG. 2 is a top plan view of the hold-down clamp of FIG. 1;

FIG. 3 is a rear elevational view of the hold-down clamp of FIG. 1;

FIG. 4 is an end elevational view of the hold-down clamp of FIG. 1 taken from the left side of FIG. 1; the end view taken from the right of FIG. 1 is a mirror image of the view shown in FIG. 4;

FIG. 5 is a front elevational view of a hold-down clamp for welding showing an alternative embodiment of my new design;

FIG. 6 is a top plan view of the hold-down clamp of FIG. 5;

FIG. 7 is a rear elevational view of the hold-down clamp of FIG. 5; and,

FIG. 8 is an end elevational view of the hold-down clamp of FIG. 5 taken from the left side of FIG. 5; the end view taken from the right of FIG. 5 is a mirror image of the view shown in FIG. 8.

The bottom surfaces of the hold-down clamps shown in FIG. 1 through 8 are plain and unadorned. The broken lines in FIGS. 1 through 8 are for environmental purposes only and form no part of the claimed design.

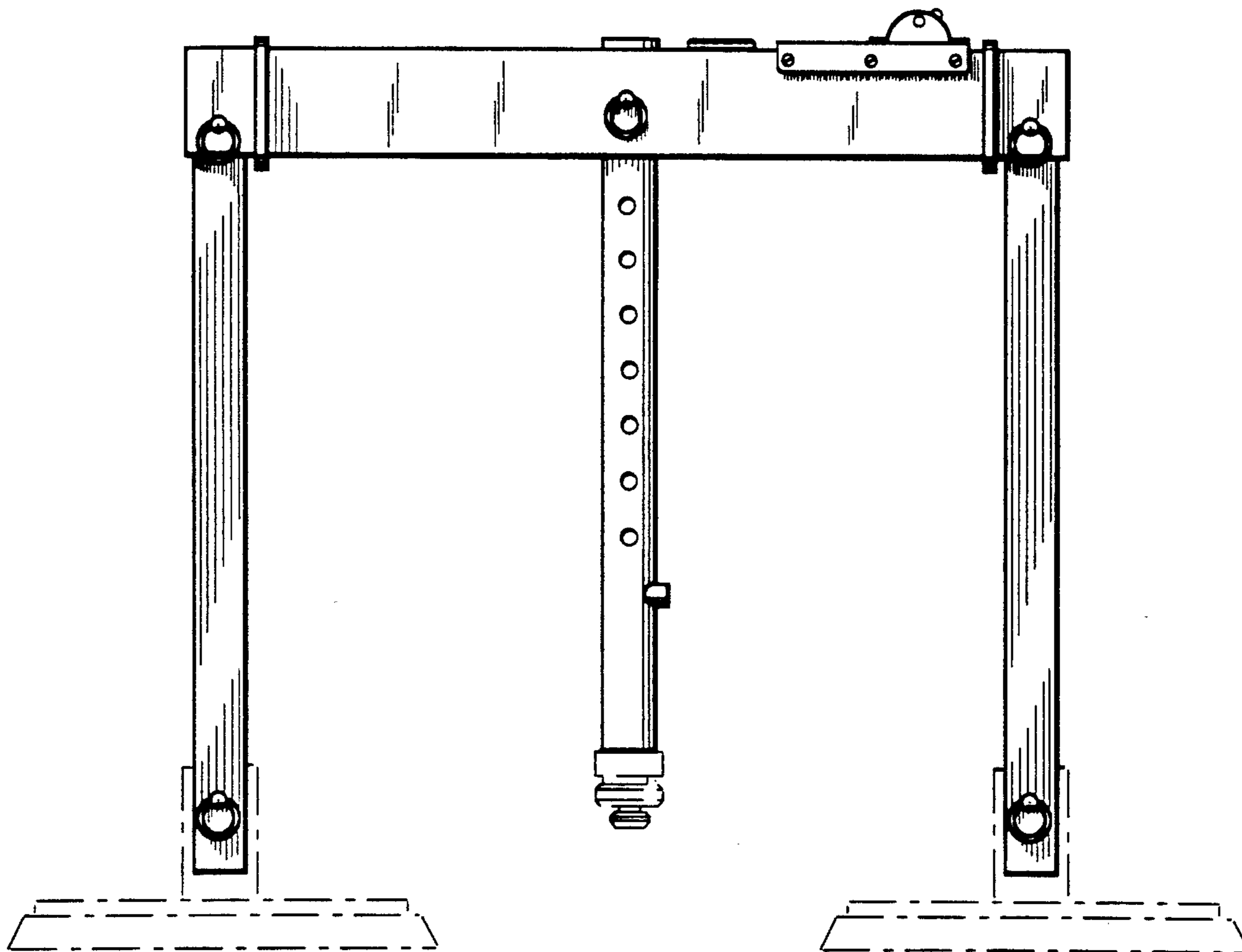

Fig. 1

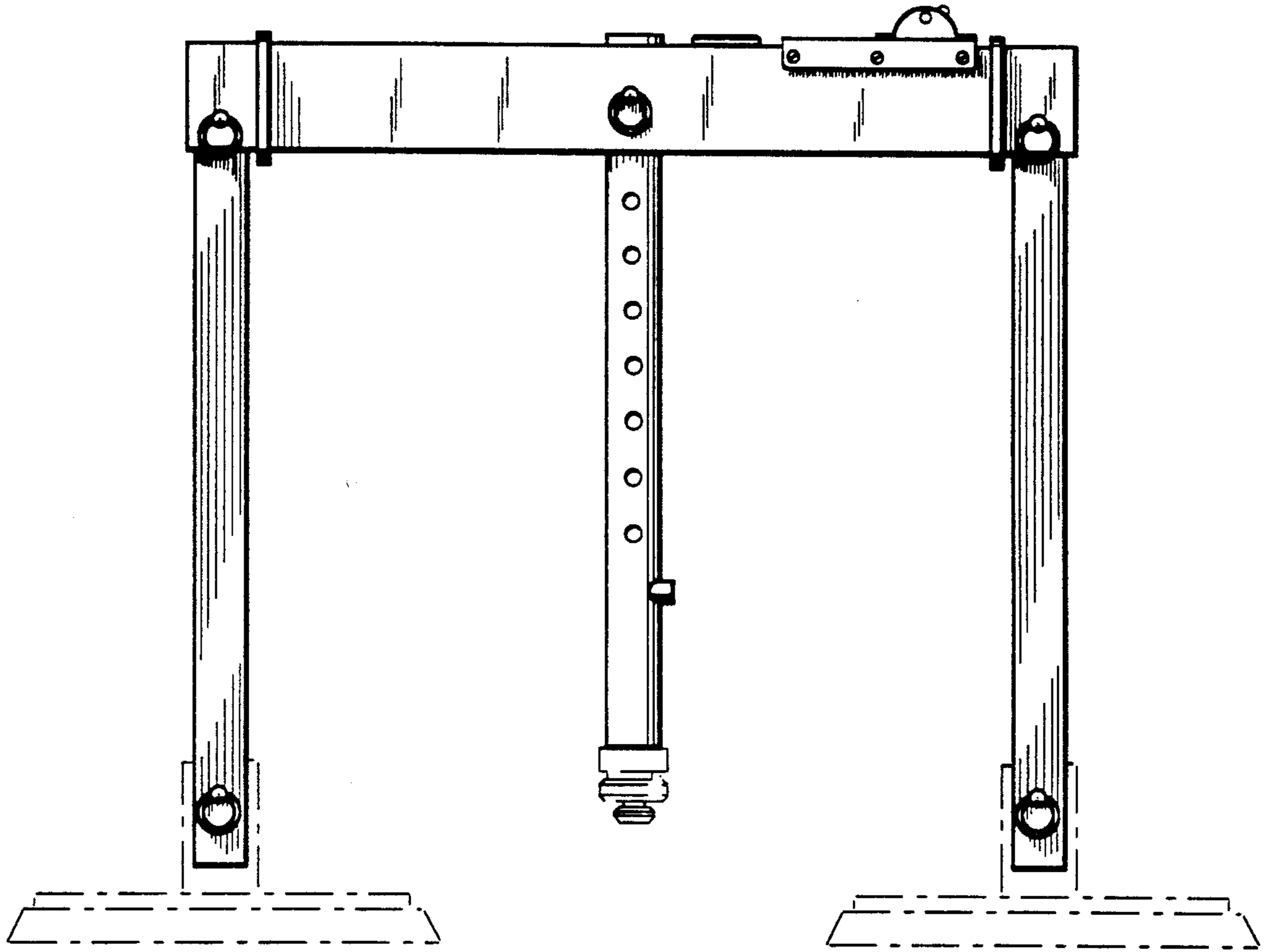

Fig. 2

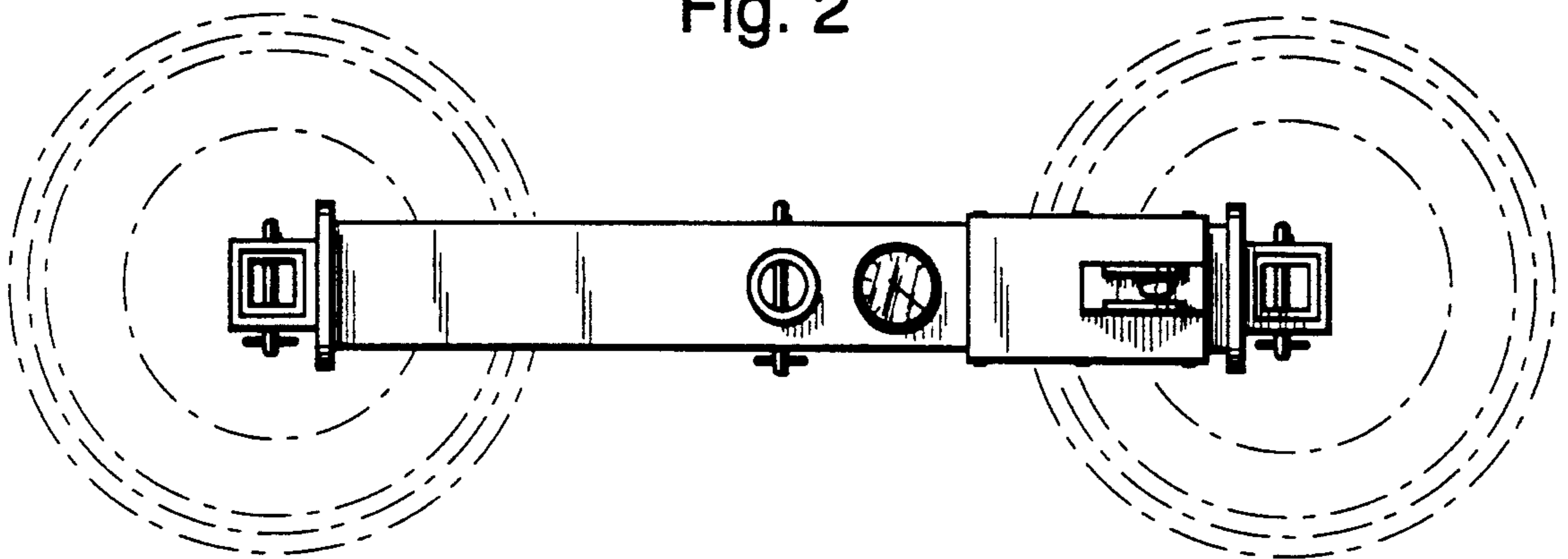

Fig. 4

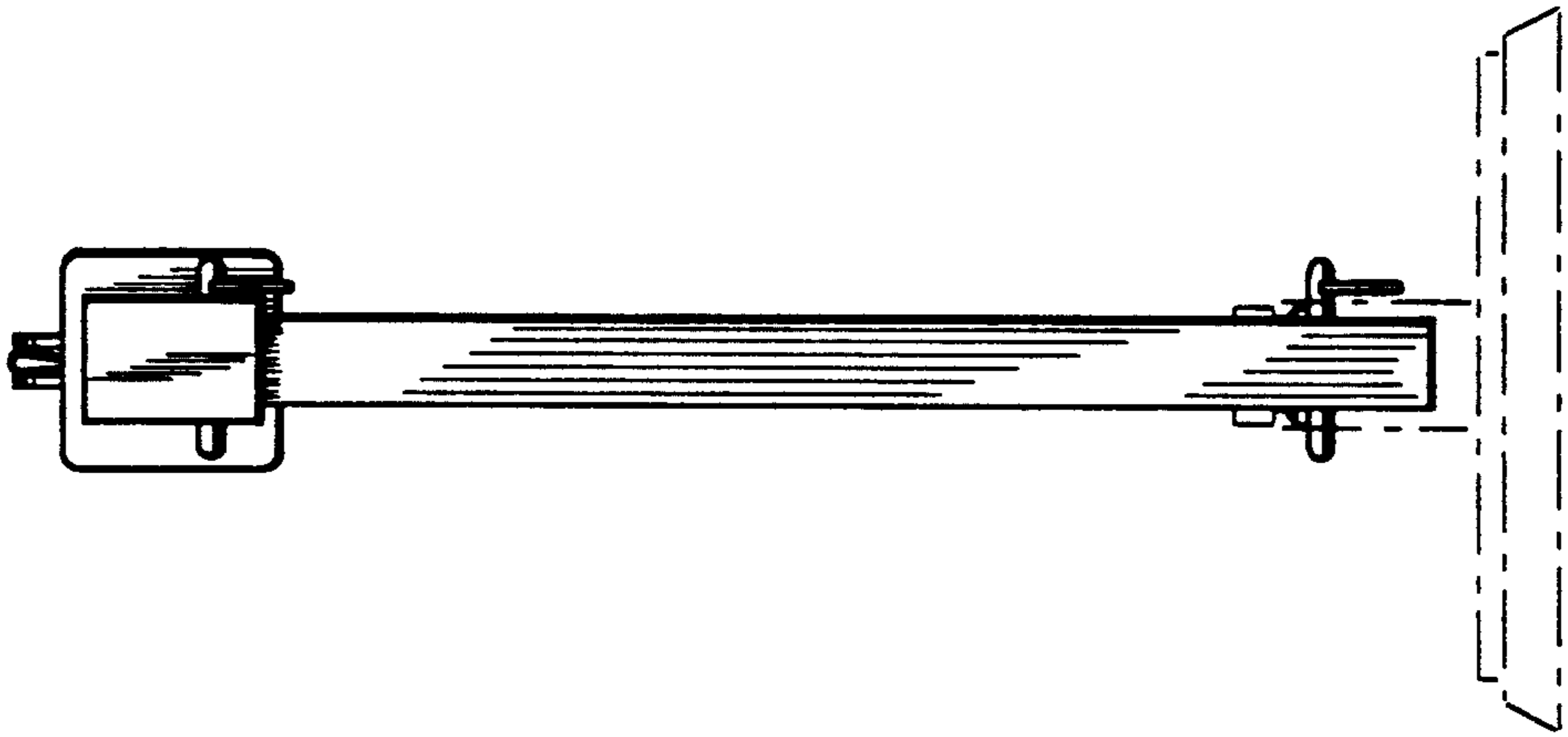
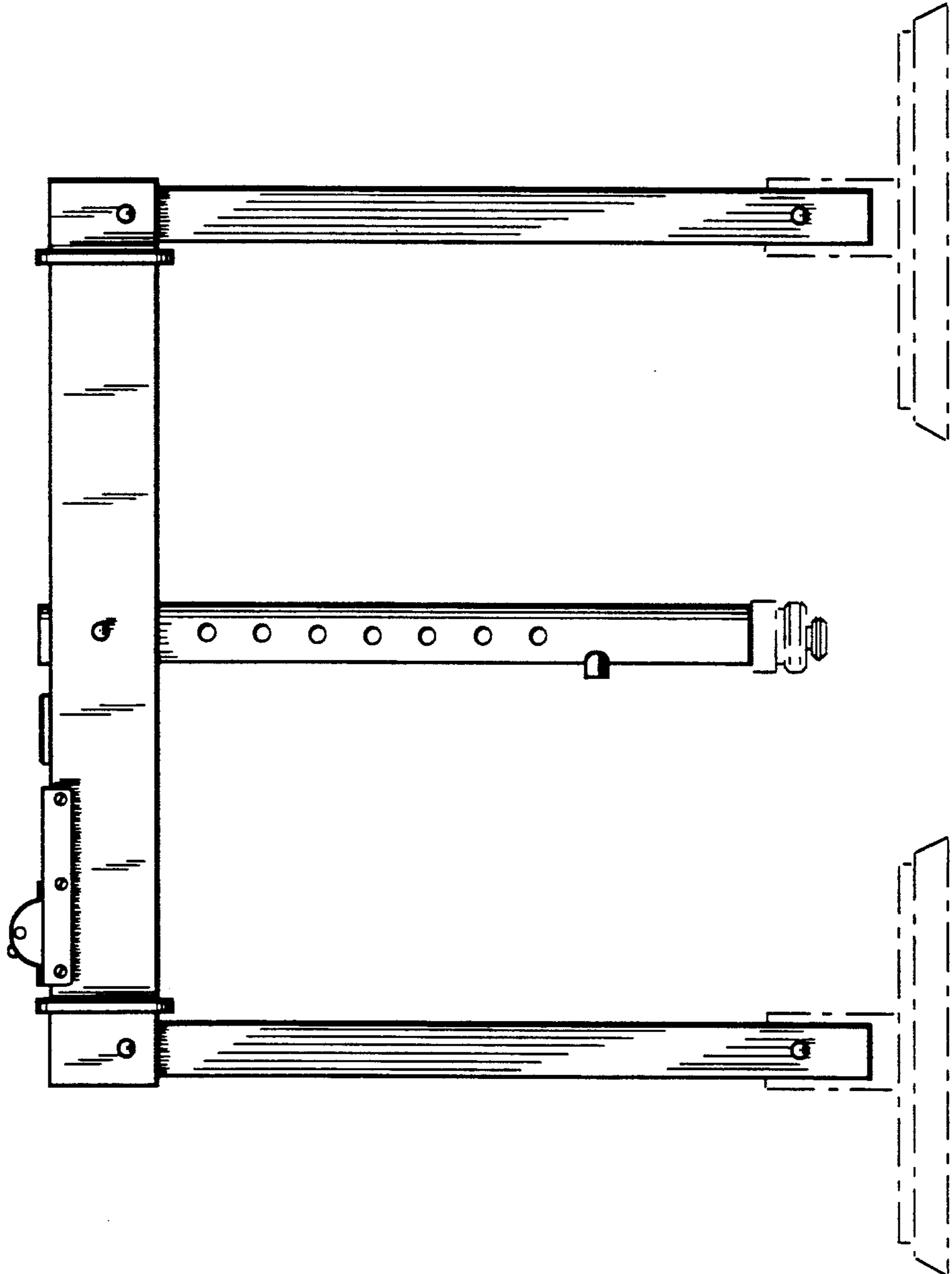

Fig. 3



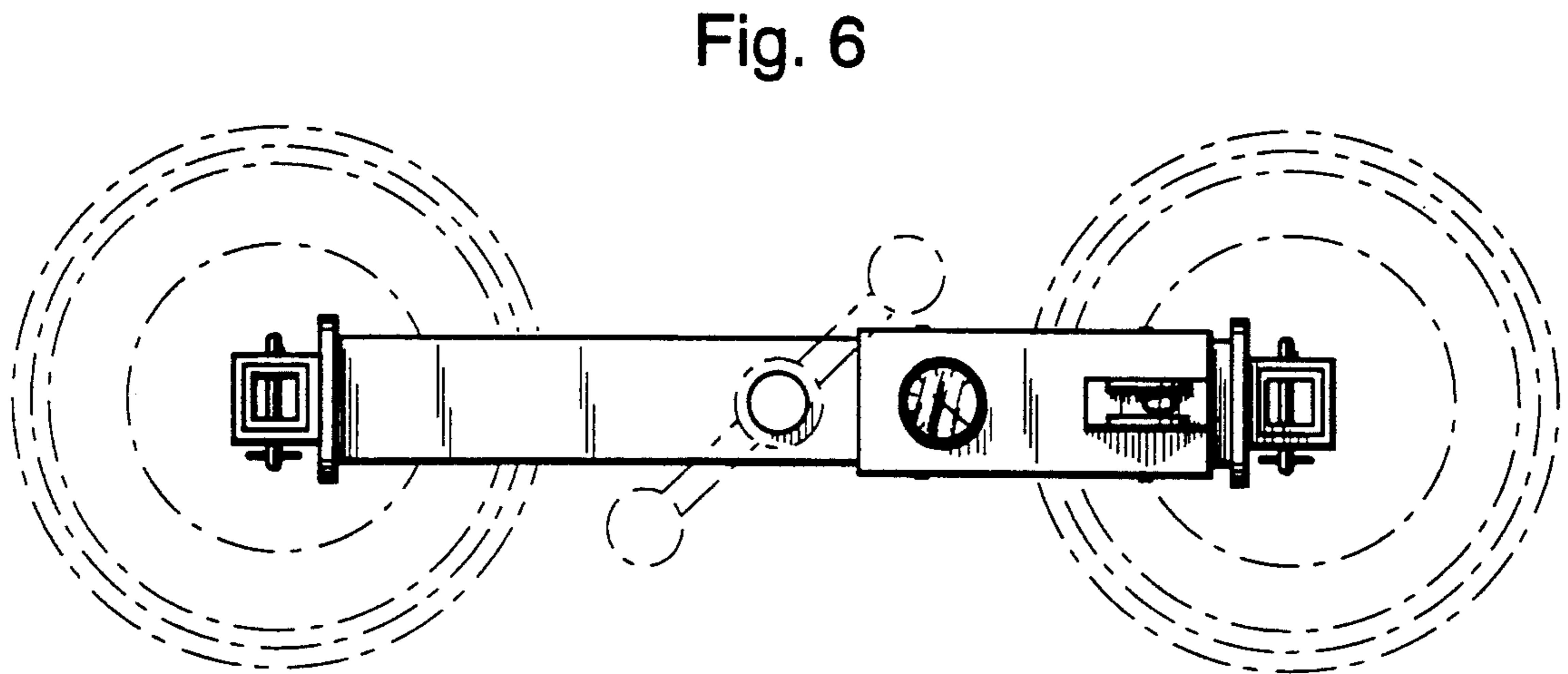
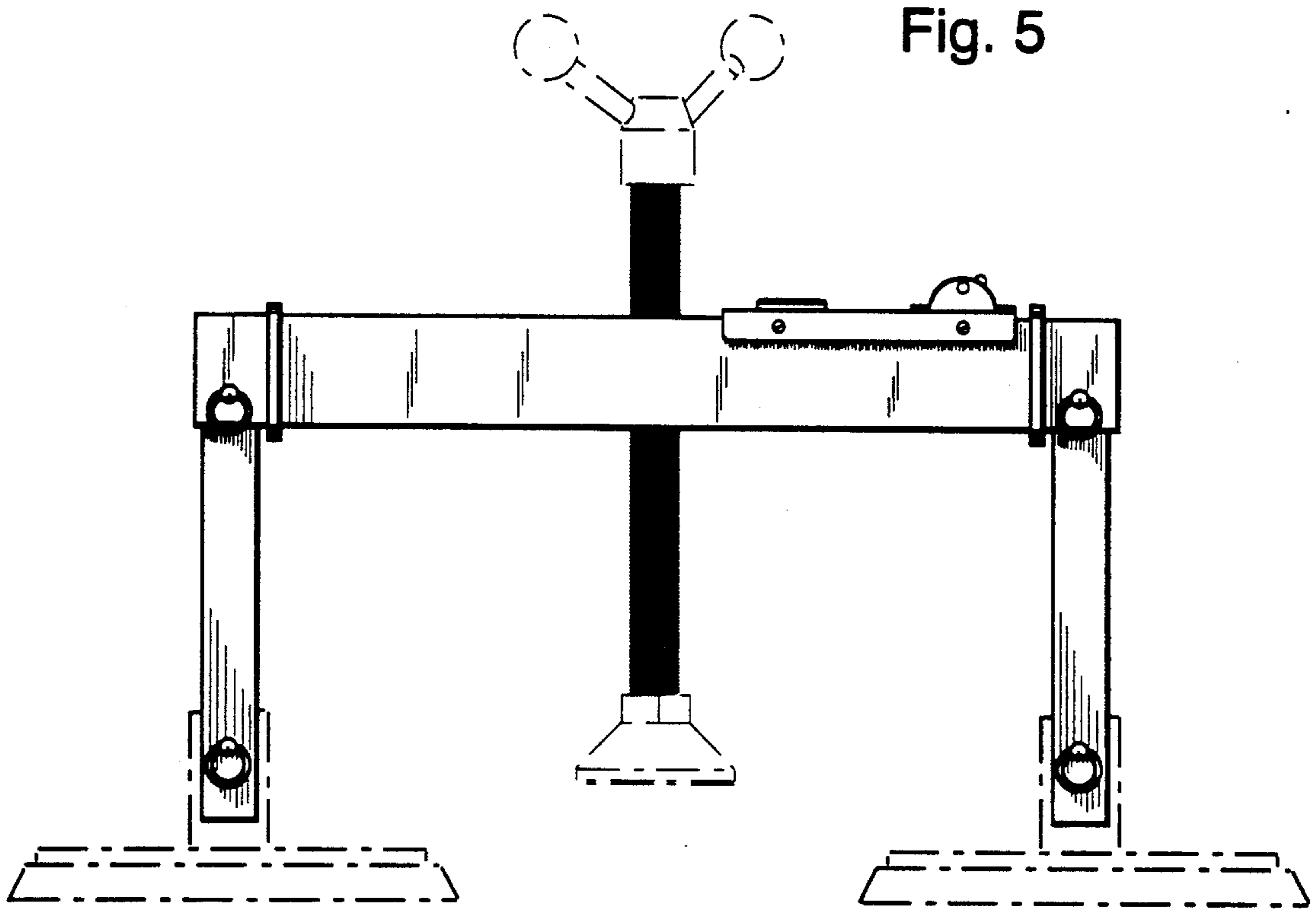

Fig. 8

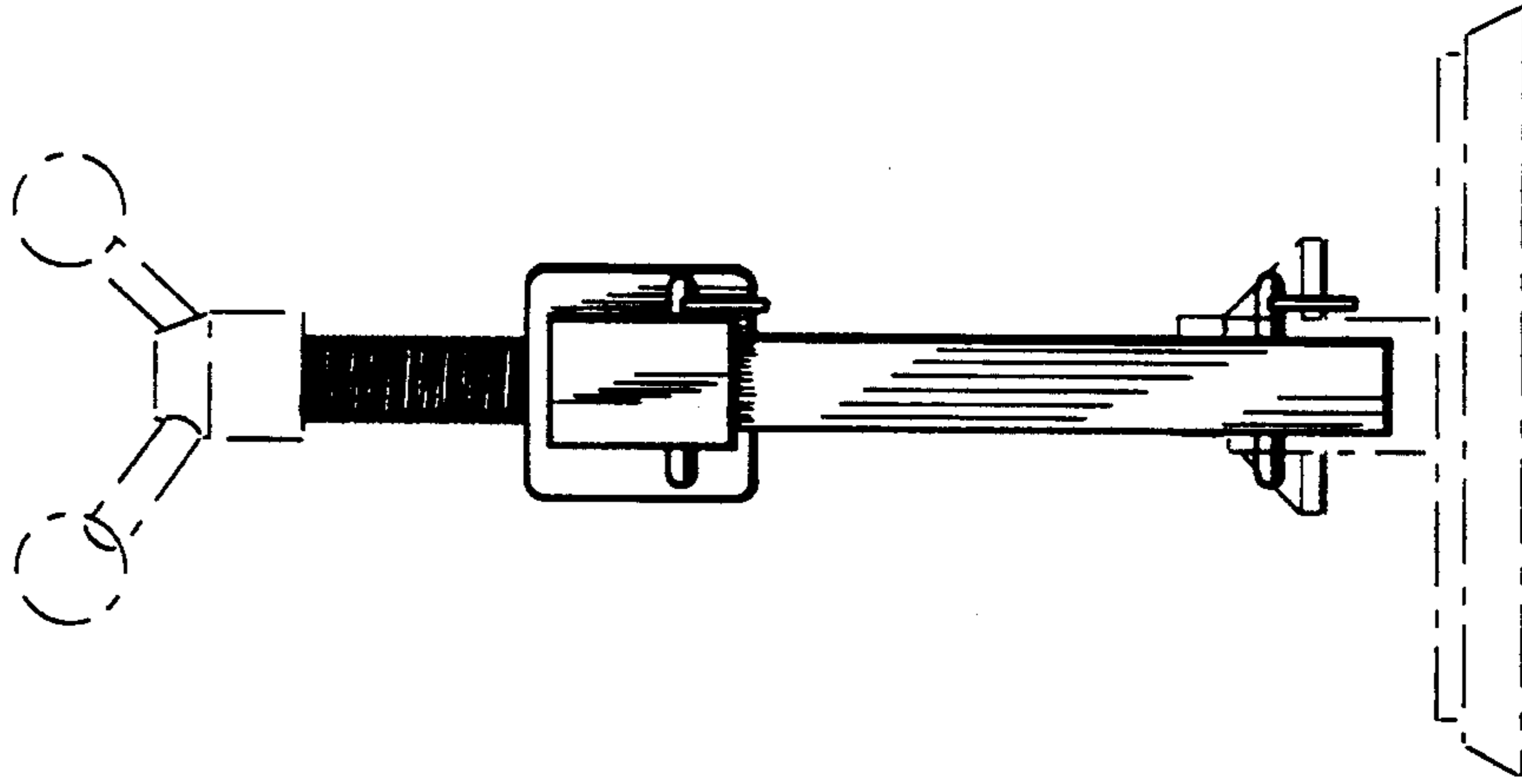

Fig. 7

