



US00D342842S

United States Patent [19]

[11] Patent Number: **Des. 342,842**

Lemon

[45] Date of Patent: **** Jan. 4, 1994**

[54] **KIDDIE RIDING TABLE**

[76] Inventor: **Evon C. Lemon**, 107 Davis Dr.,
Williamsburg, Va. 23185

[**] Term: **14 Years**

[21] Appl. No.: **886,470**

[22] Filed: **May 21, 1992**

[52] U.S. Cl. **D6/406; D6/333;**
D6/334; D6/338; D6/339; D6/406; D6/491;
D6/500-502

[58] Field of Search 297/148, 150, 153, 217,
297/216, 253, 254, 467, 487, 488; 108/43

[56] **References Cited**

U.S. PATENT DOCUMENTS

D. 193,244	7/1962	Bliss	D6/406
D. 247,205	2/1978	Nabugat	D6/406
D. 298,091	10/1988	Wilson	D6/406
D. 308,404	6/1990	Goodwin	D6/338 X
D. 335,045	4/1993	Ferrari et al.	D6/382

FOREIGN PATENT DOCUMENTS

2729319 1/1979 Fed. Rep. of Germany 297/487

OTHER PUBLICATIONS

Atlas Gifts 1985, p. 5, Sunshine at bottom.

Primary Examiner—Alan P. Douglas

Assistant Examiner—J. E. Seeger

Attorney, Agent, or Firm—S. Michael Bender

[57] **CLAIM**

The ornamental design for a kiddie riding table, as shown and described.

DESCRIPTION

FIG. 1 is a front elevational view of the kiddie riding table showing my new design;
 FIG. 2 is a rear elevational view thereof;
 FIG. 3 is a left side elevational view thereof;
 FIG. 4 is a right side elevational view thereof;
 FIG. 5 is a top plan view thereof;
 FIG. 6 is a bottom plan view thereof; and,
 FIG. 7 is a top right perspective view thereof, the broken lines are for environmental purposes only and form no part of the claimed design.

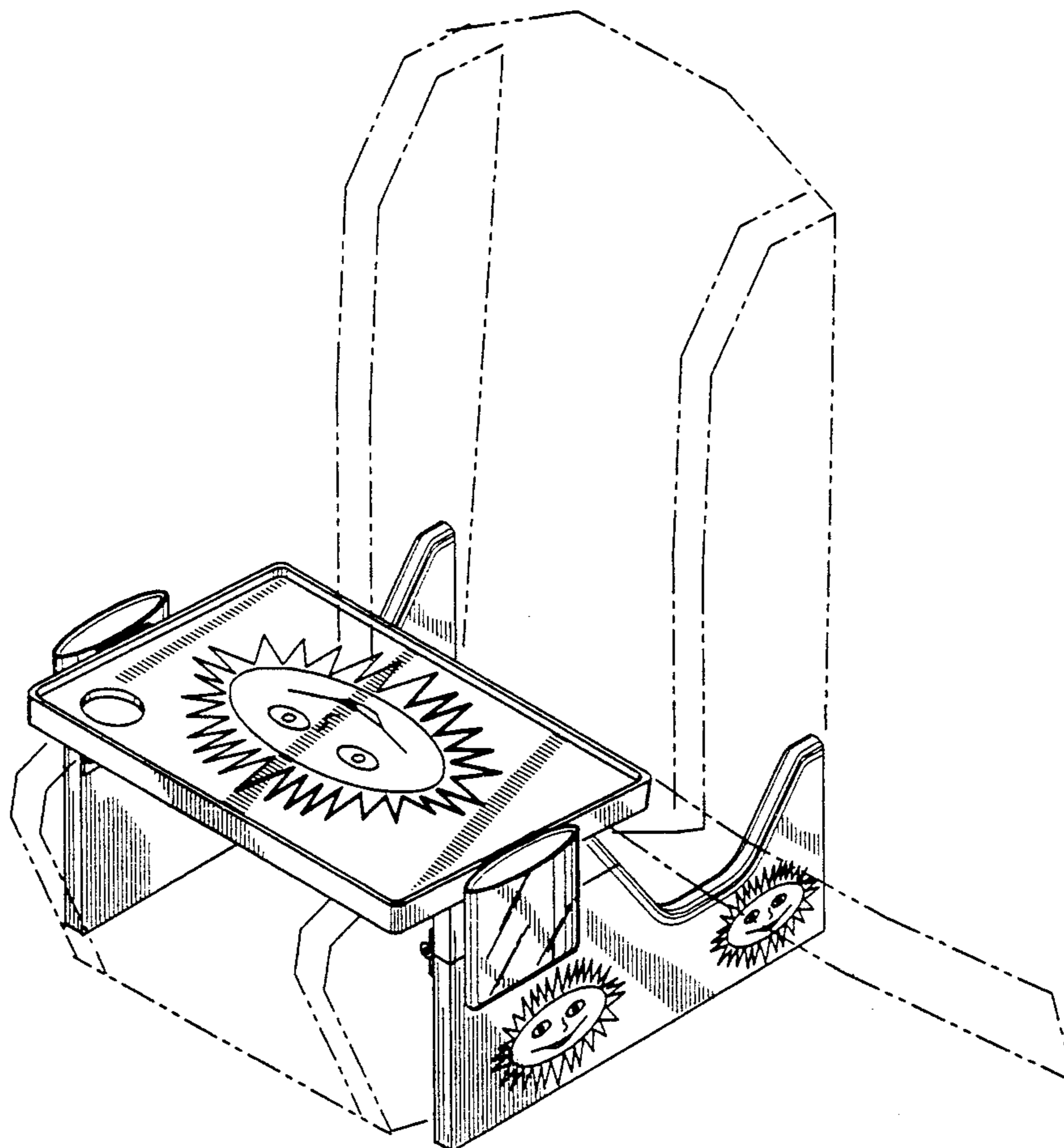

FIG. 1

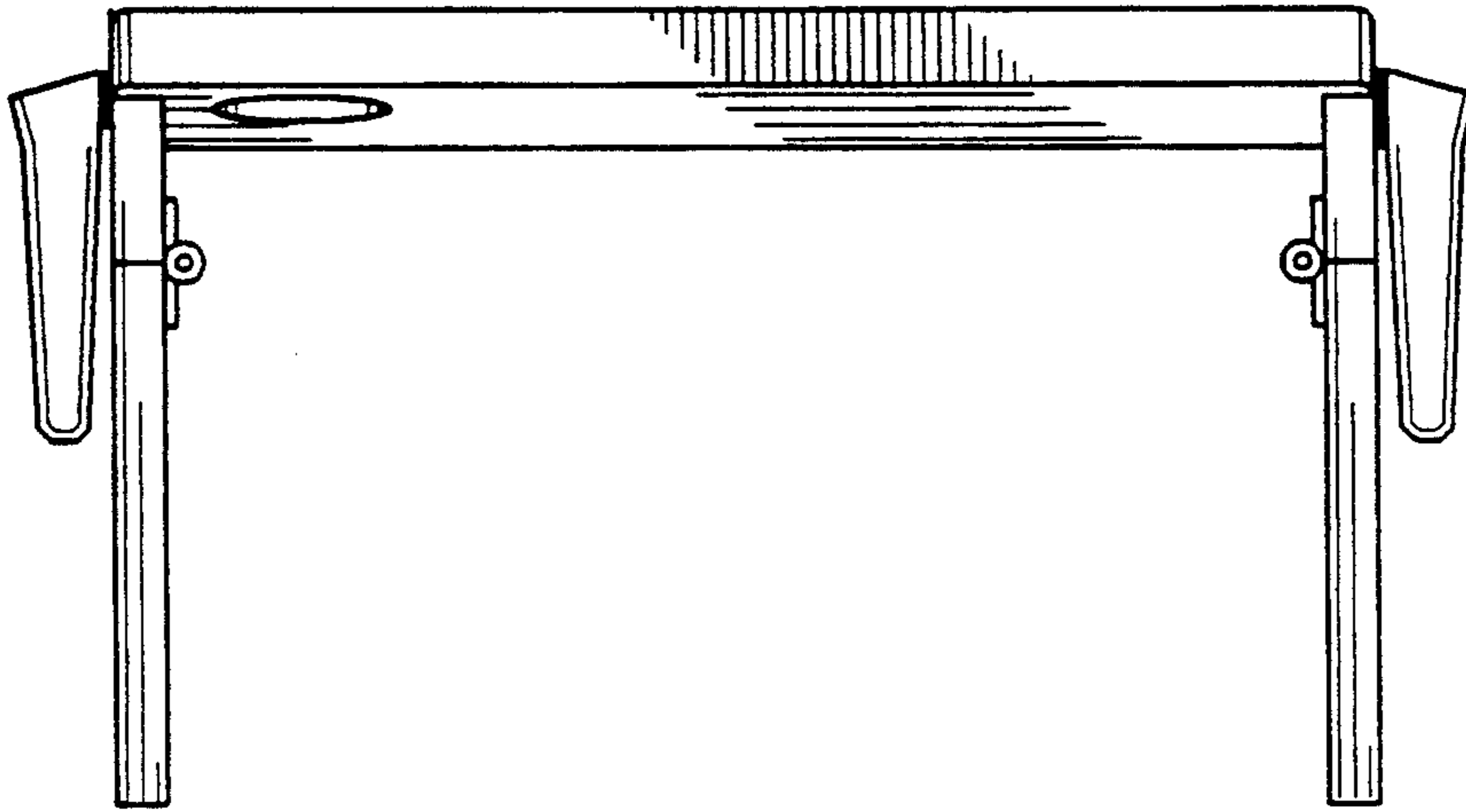

FIG. 2

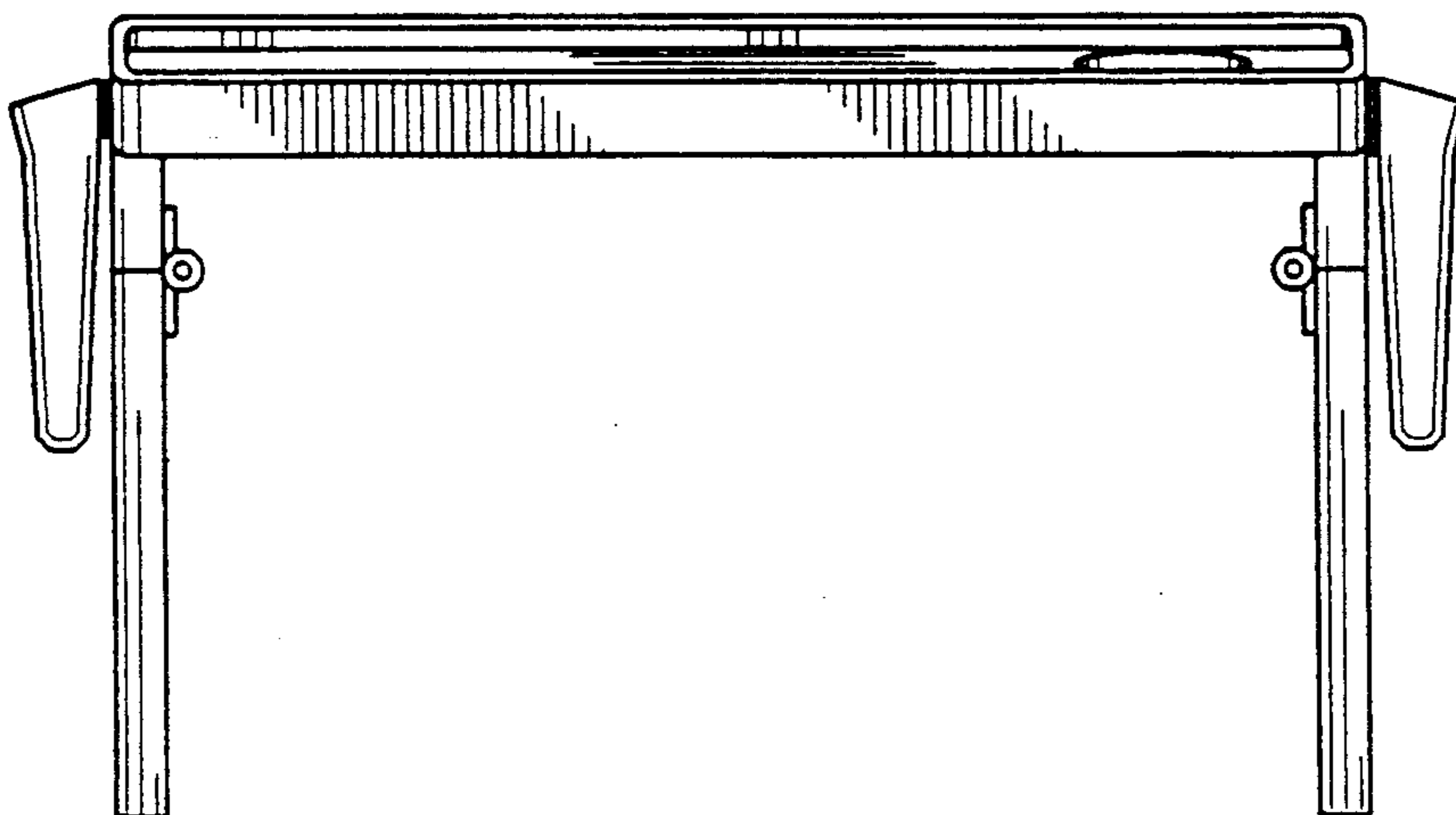

FIG. 3

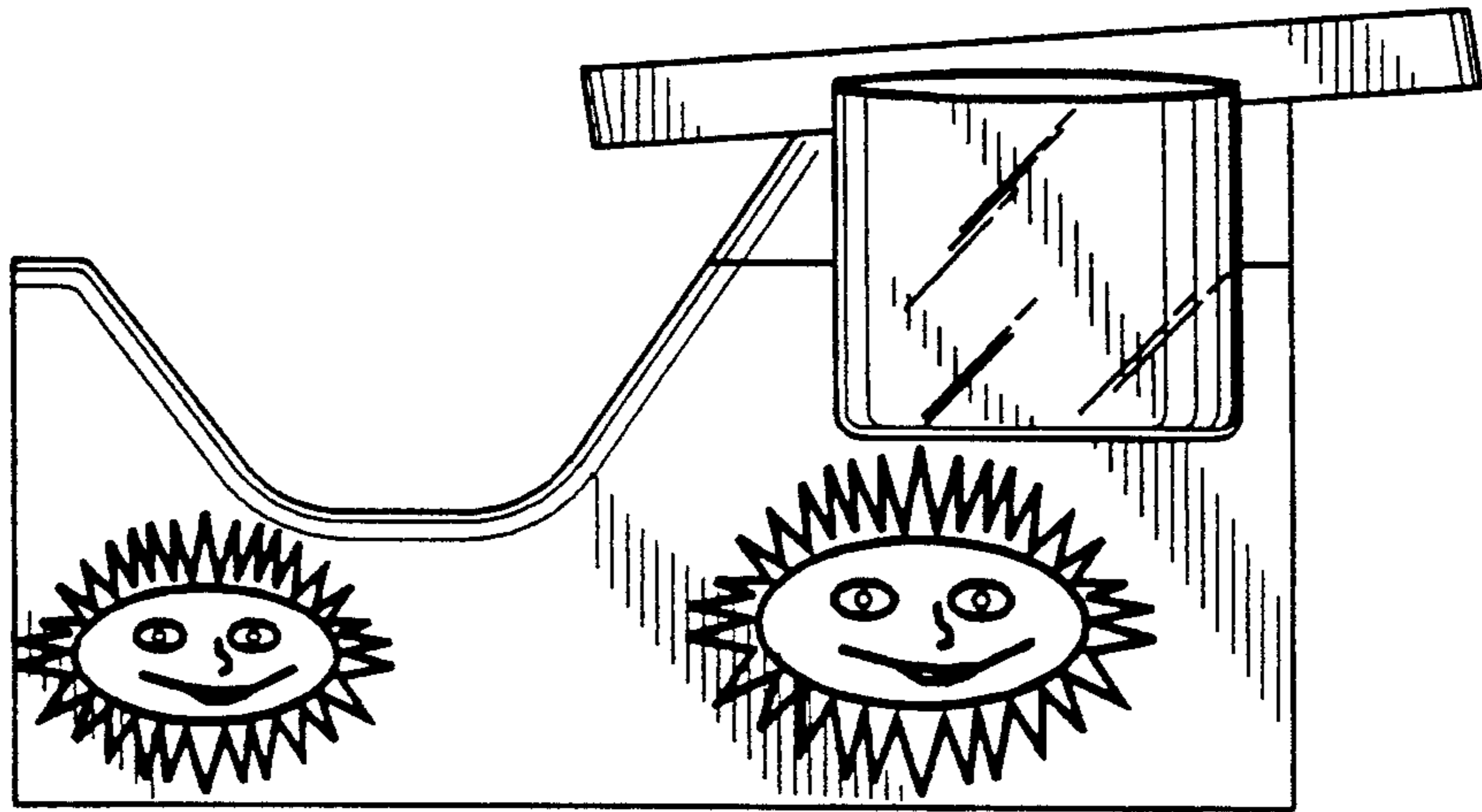
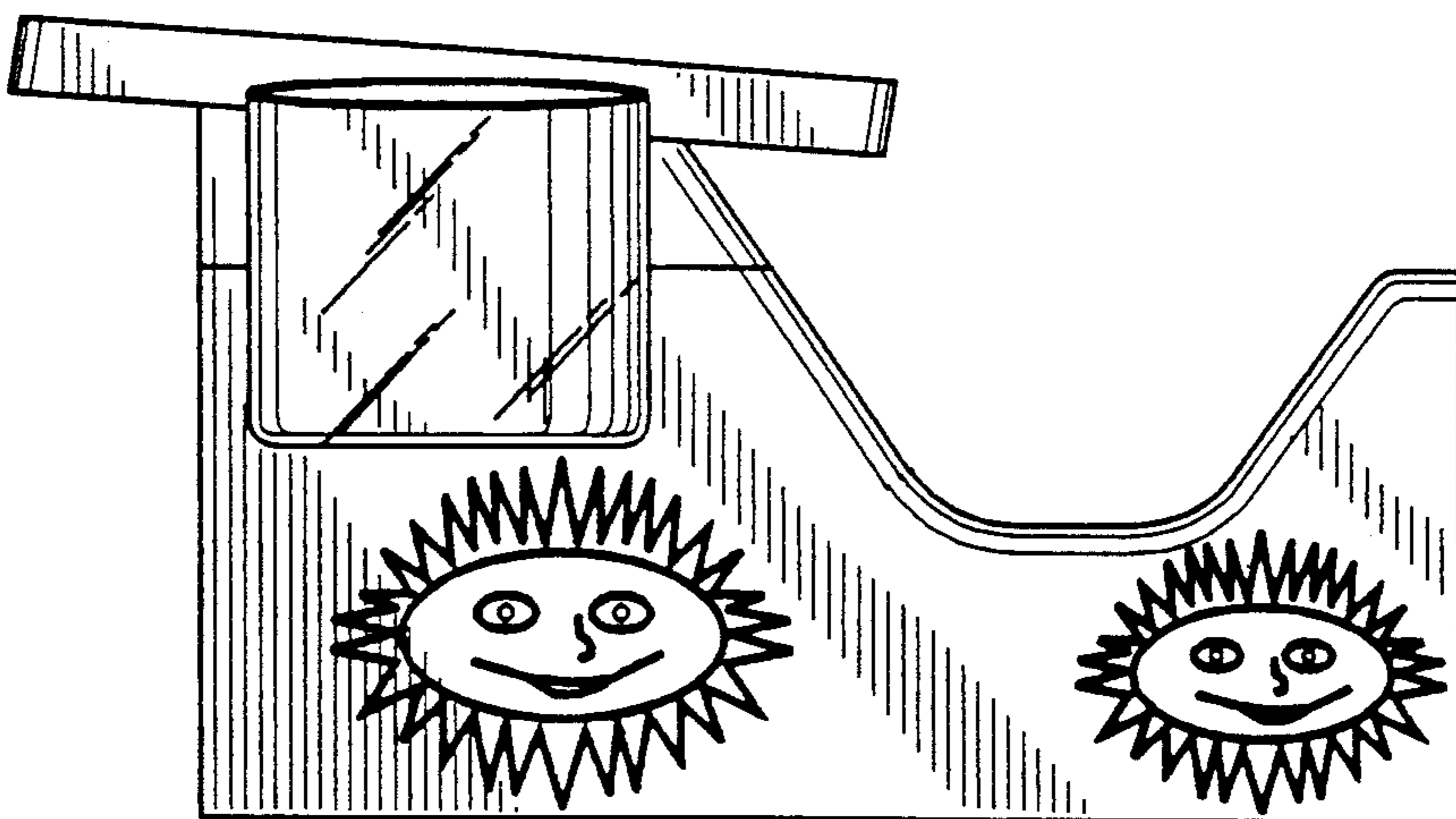

FIG. 4



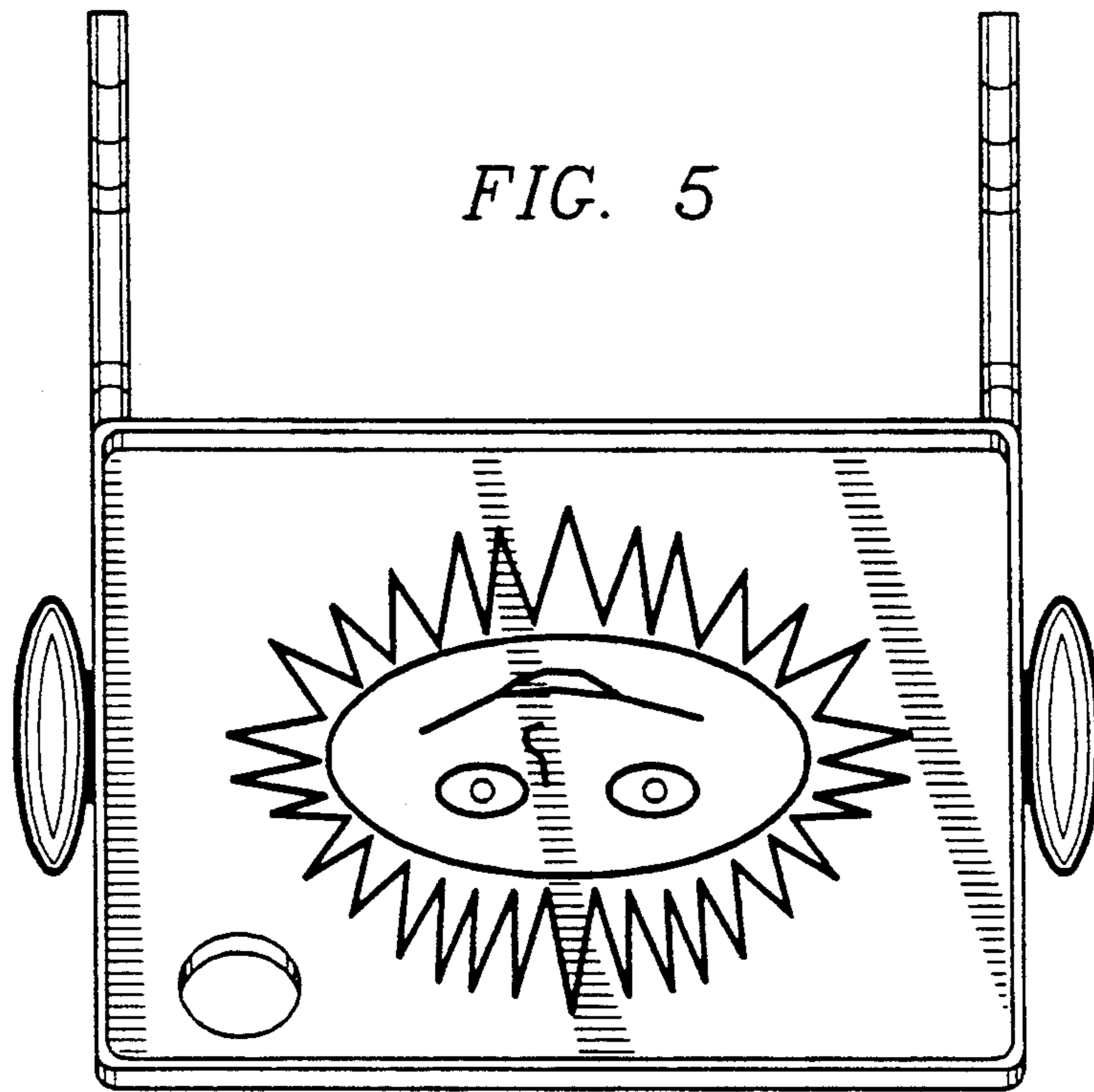
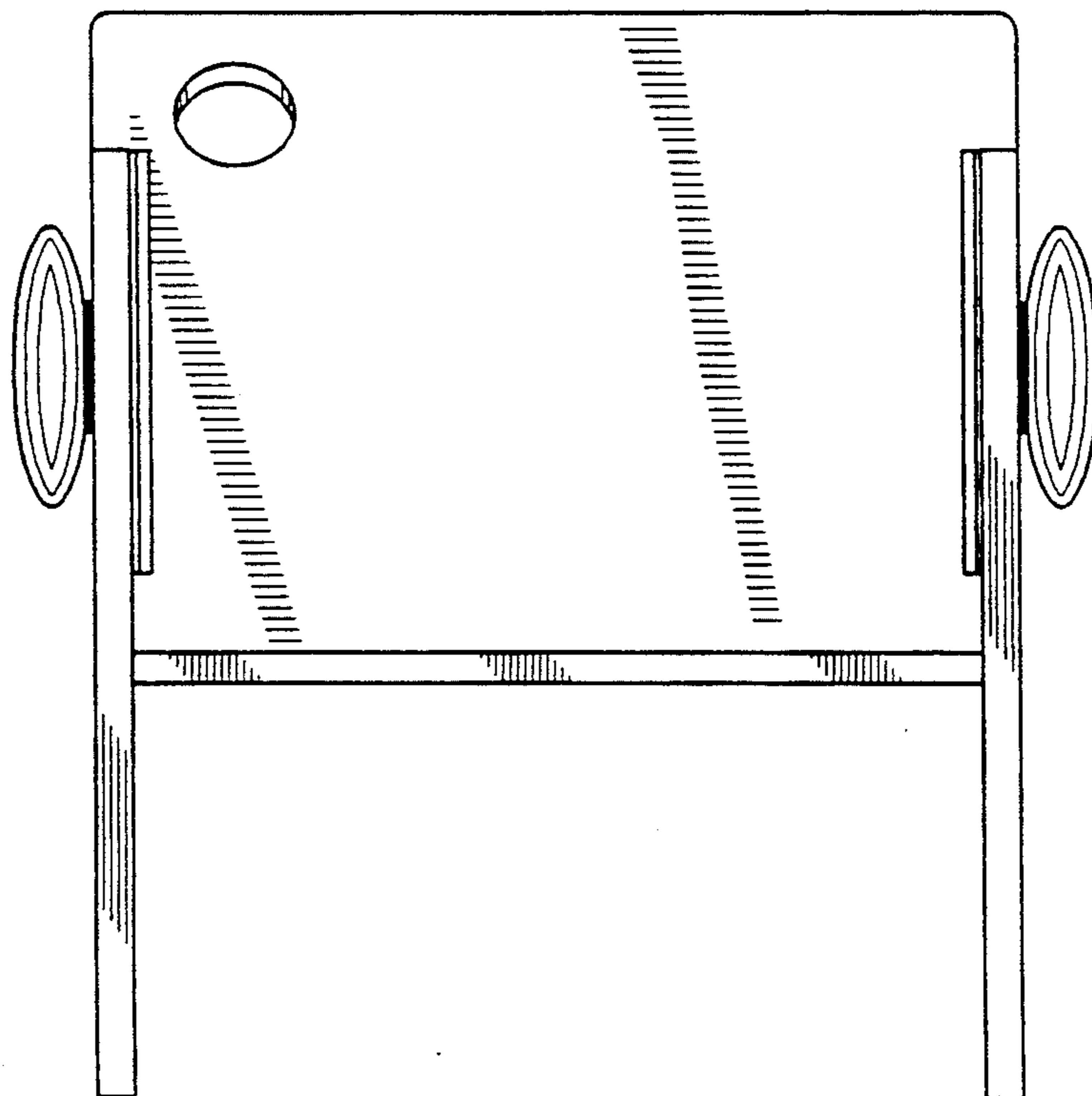

FIG. 6



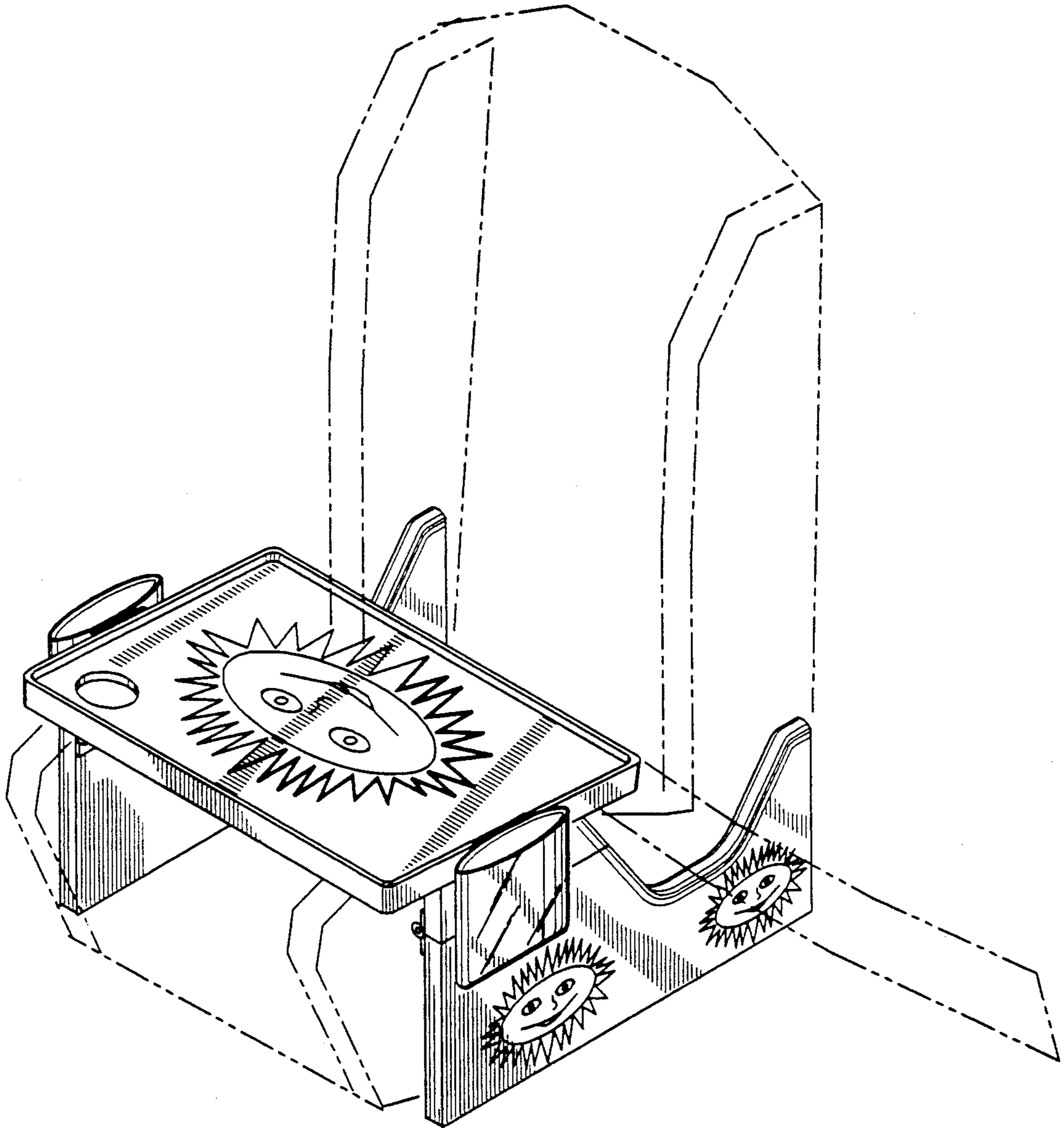

FIG. 7