



US00D342715S

# United States Patent [19]

Garrett

[11] Patent Number: Des. 342,715

[45] Date of Patent: \*\* Dec. 28, 1993

[54] COMPARTMENTALIZED OIL TANKER

4,759,307 7/1988 Scott .

4,841,901 6/1989 McGlew ..... D12/318

[76] Inventor: **Floyd L. Garrett**, 1200 N. Oak Ave.,  
Box 2213, Ada, Okla. 74820

### FOREIGN PATENT DOCUMENTS

[\*\*] Term: **14 Years**

803663 10/1936 France .

1479025 5/1966 France .

[21] Appl. No.: **726,507**

[22] Filed: **Jul. 8, 1991**

[52] U.S. Cl. .... **D12/300; D21/130**

[58] Field of Search ..... **D21/130, 71, 73;**  
**D12/300, 315, 318; 446/7, 94, 153, 160, 487;**  
**114/56, 72, 74 R**

*Primary Examiner*—Bernard Ansher  
*Assistant Examiner*—R. Barkai  
*Attorney, Agent, or Firm*—Terry M. Gernstein

### [57] CLAIM

The ornamental design for a compartmentalized oil tanker, as shown and described.

### [56] References Cited

#### U.S. PATENT DOCUMENTS

D. 103,871	3/1937	Height .....	D21/130
D. 168,102	11/1952	Matzen .....	D21/130
D. 221,406	8/1971	Kimon .....	D12/315
1,380,110	5/1921	McDougall .....	114/74 R
3,145,854	8/1964	Sturm .....	114/72
4,046,092	9/1977	Tornqvist .....	114/56
4,468,170	8/1984	Hanset .	
4,700,650	10/1987	Nishida .	

### DESCRIPTION

FIG. 1 is a perspective view of the compartmentalized oil tanker embodying the design of the present invention;  
FIG. 2 is a front elevational view thereof;  
FIG. 3 is a rear elevational view thereof;  
FIG. 4 is an end elevational view thereof;  
FIG. 5 is an end elevational view thereof;  
FIG. 6 is a top plan view thereof; and,  
FIG. 7 is a bottom view thereof.

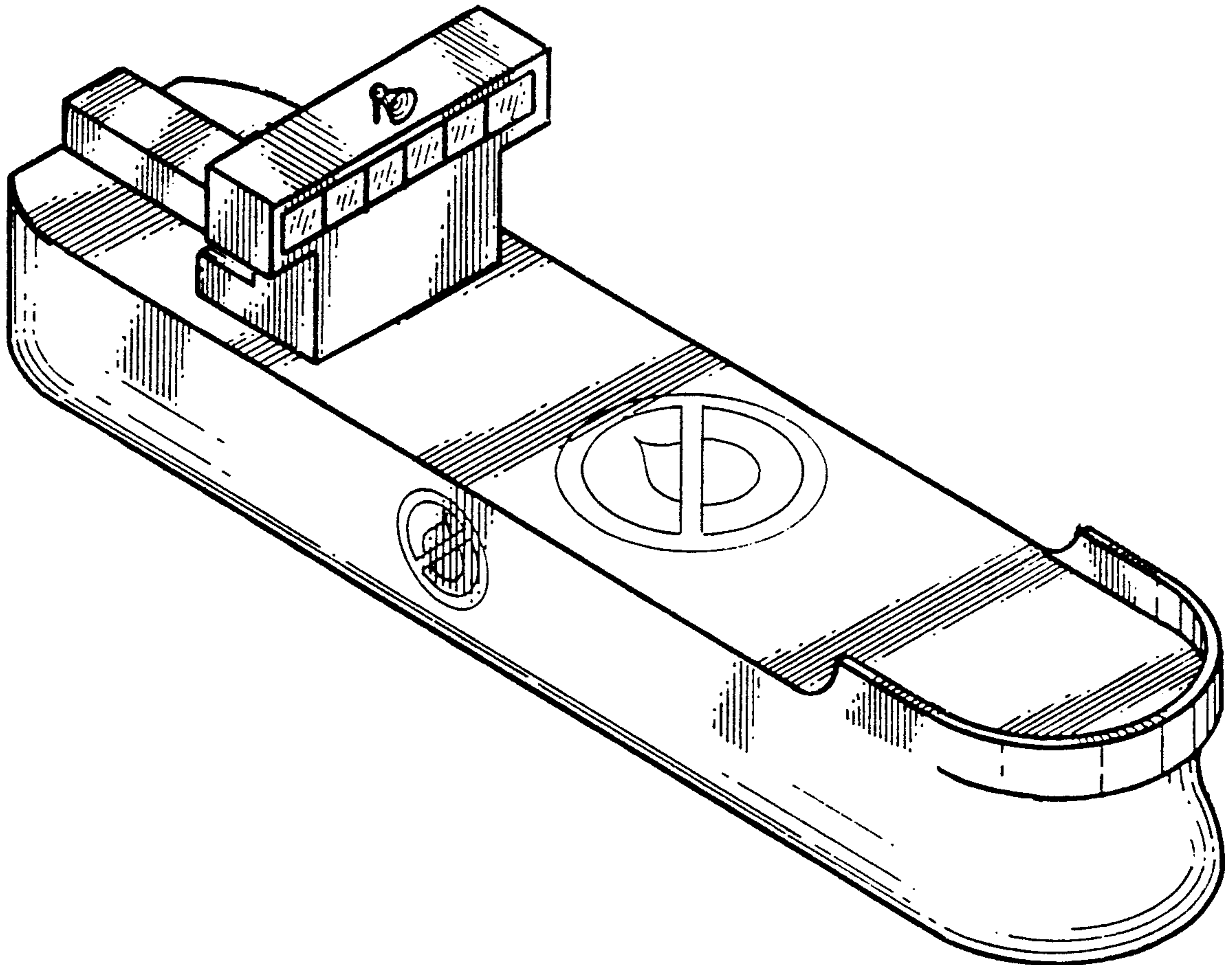

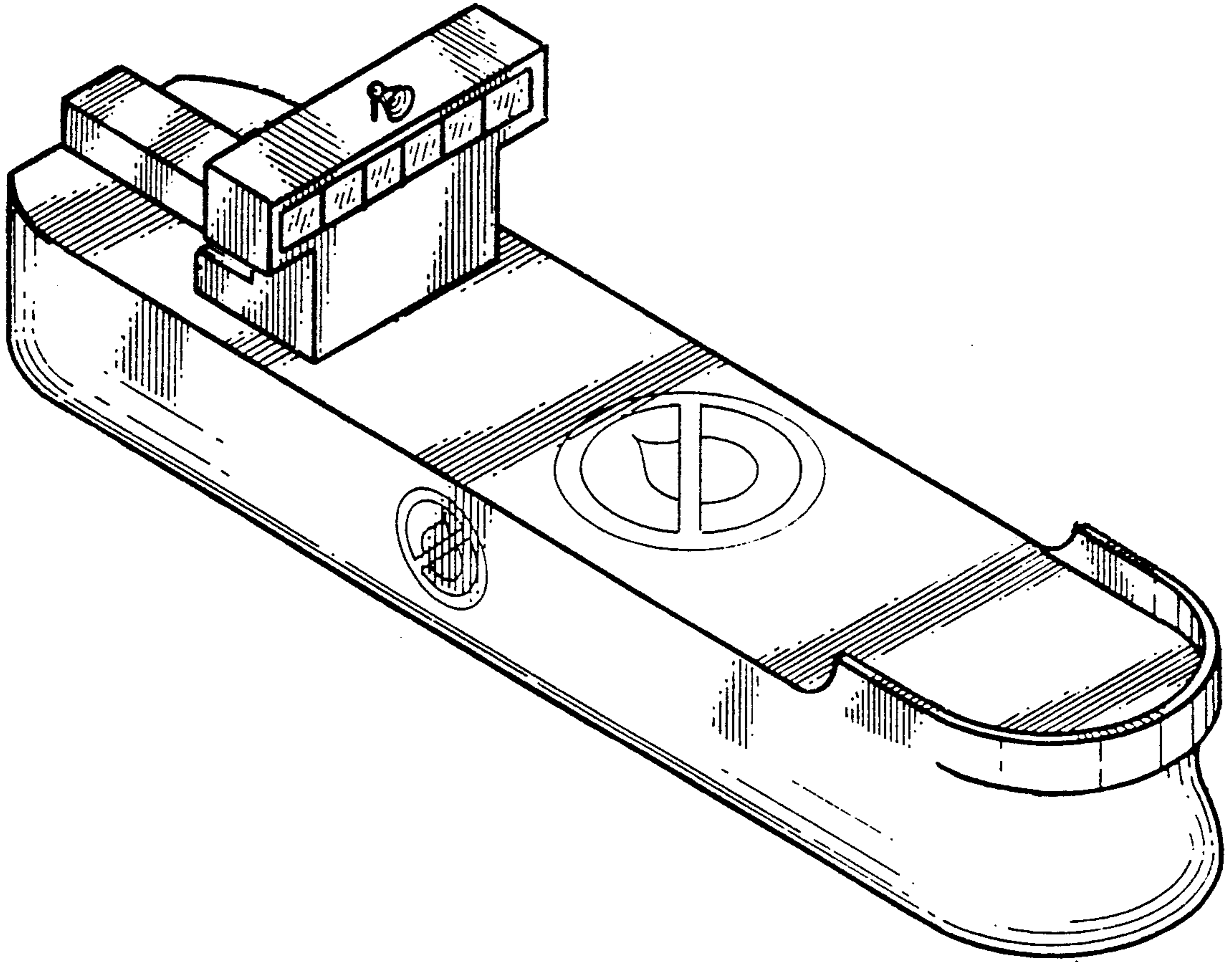

FIG. 1

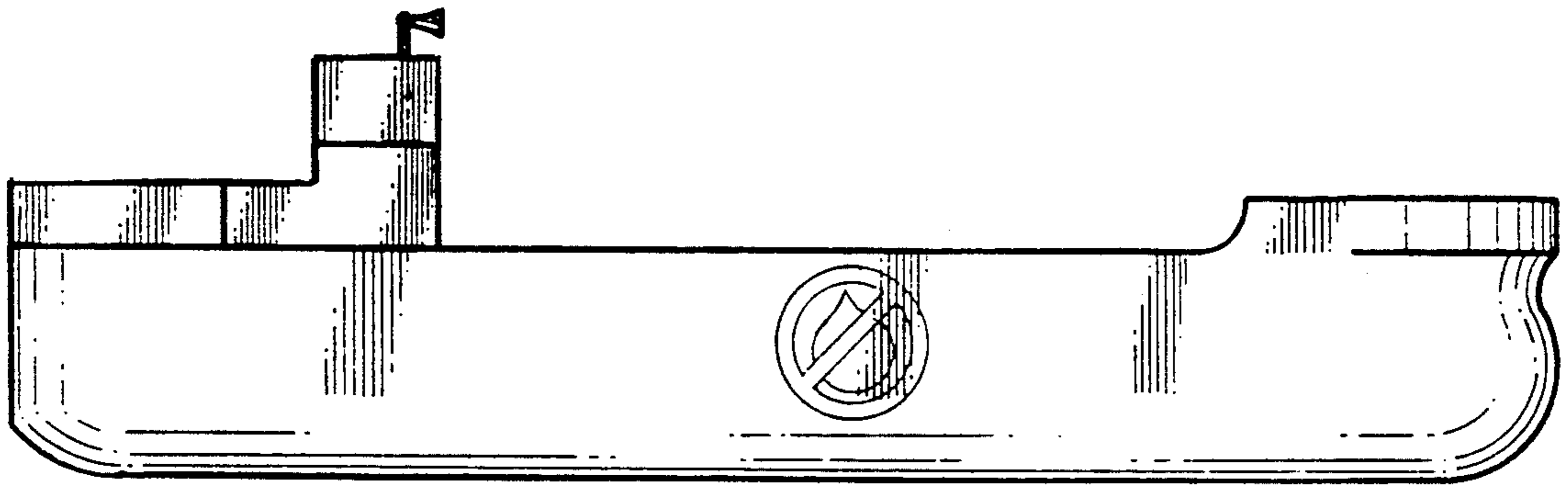

FIG. 2

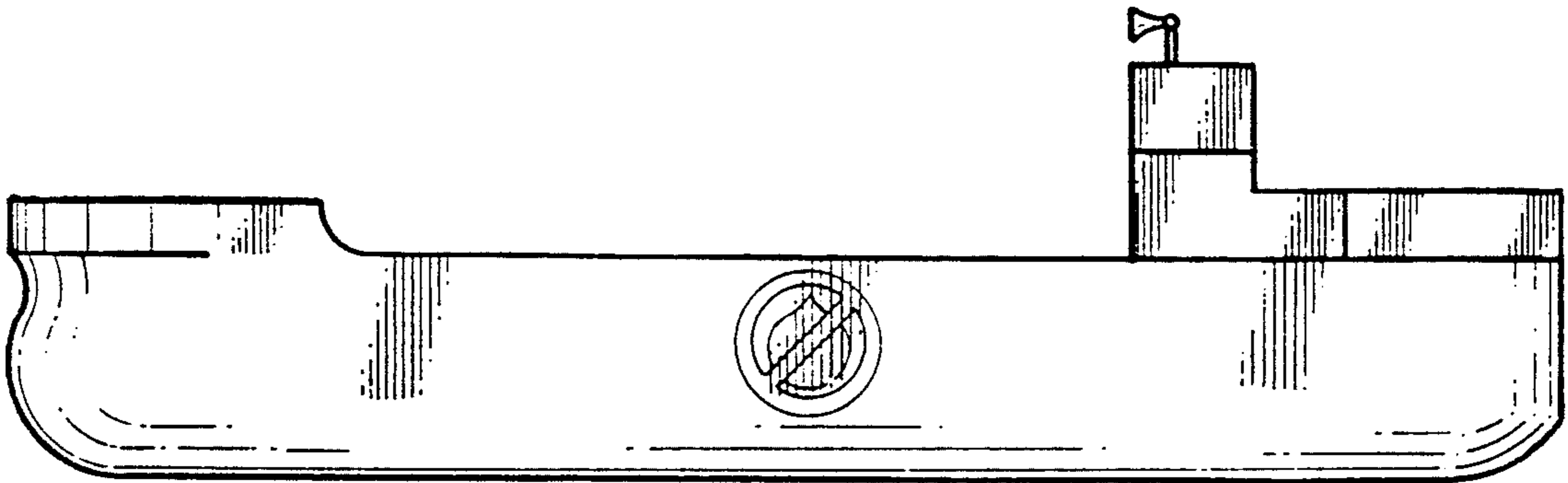

FIG. 3

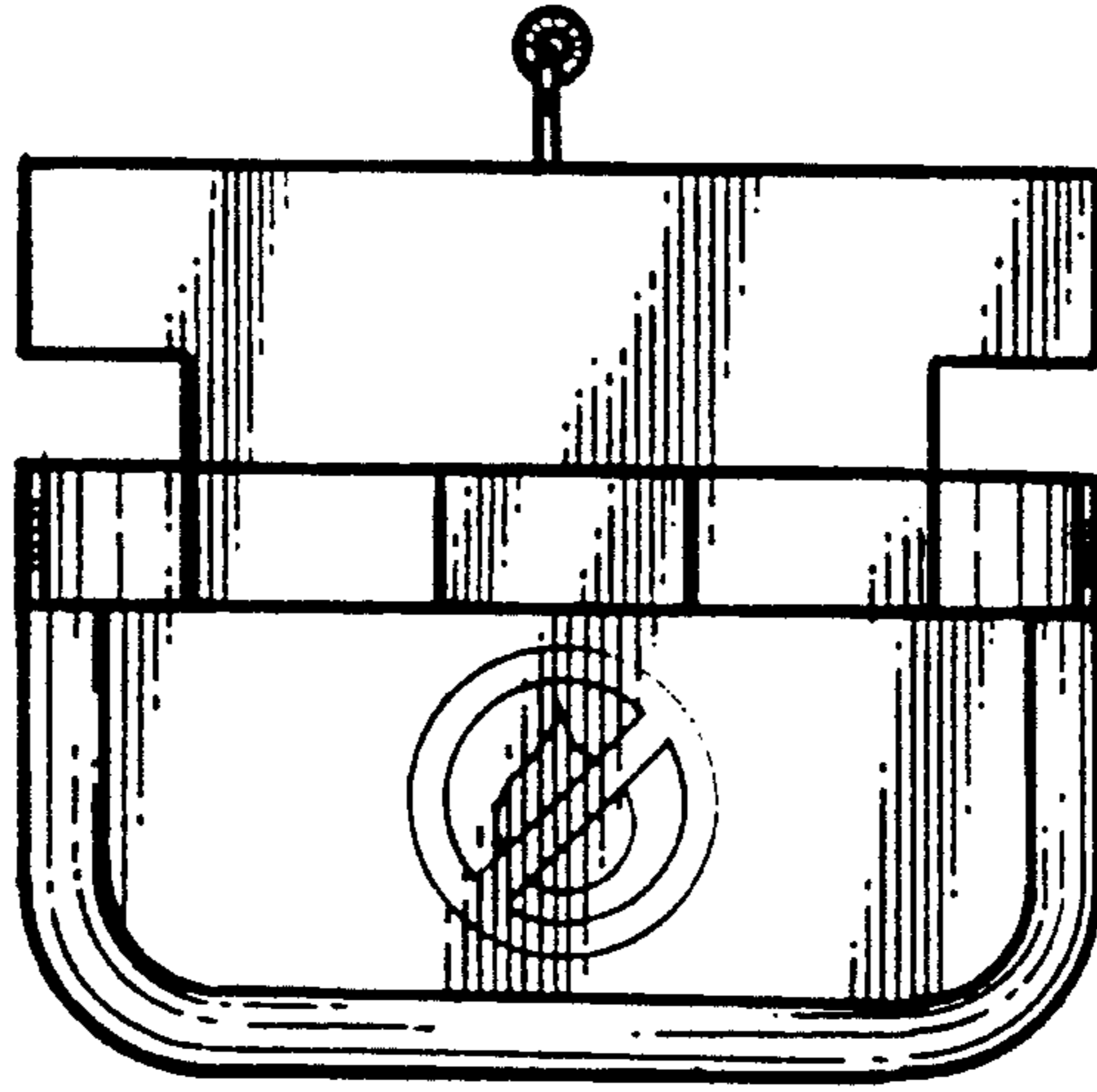

FIG. 4

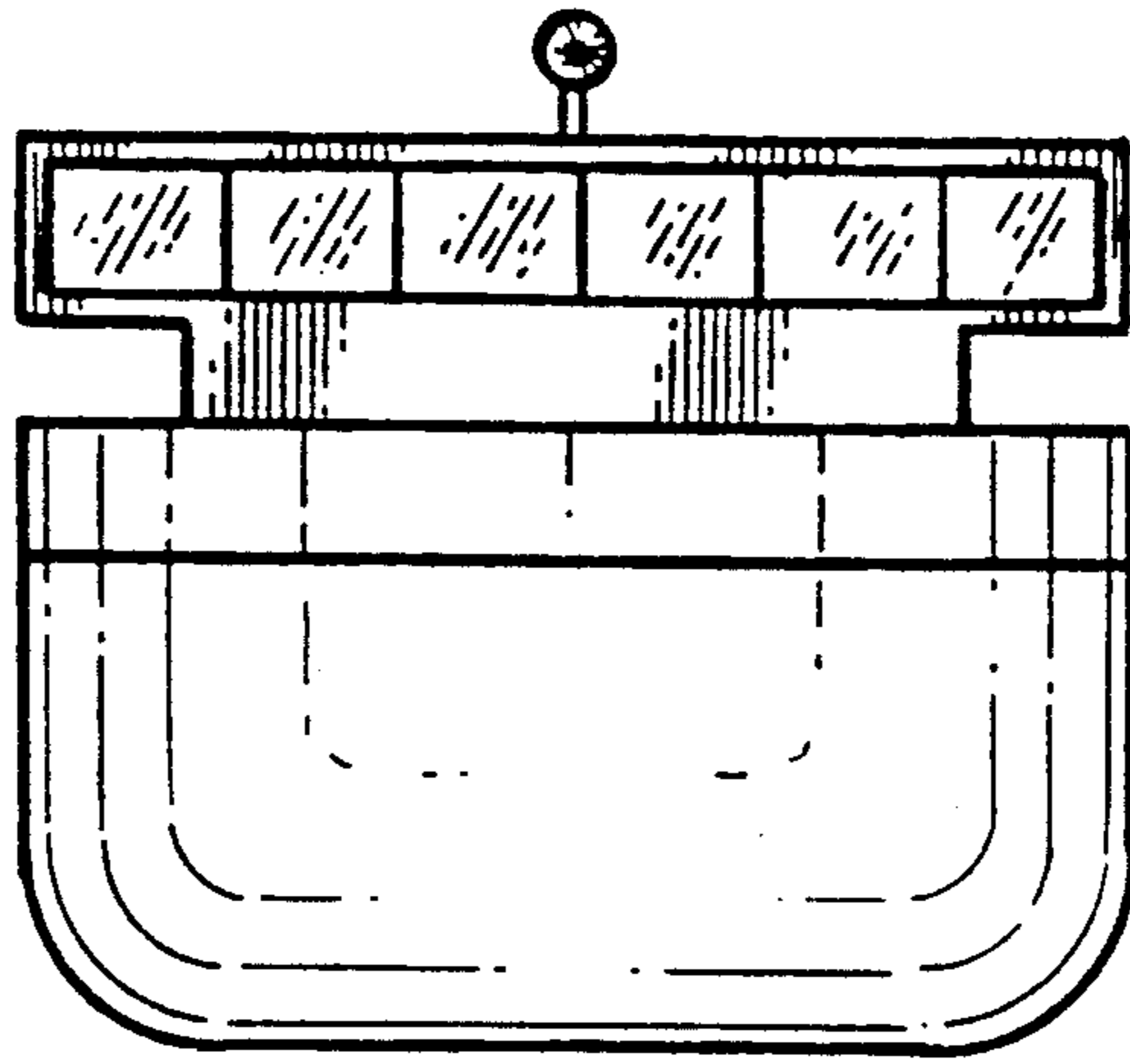

FIG. 5



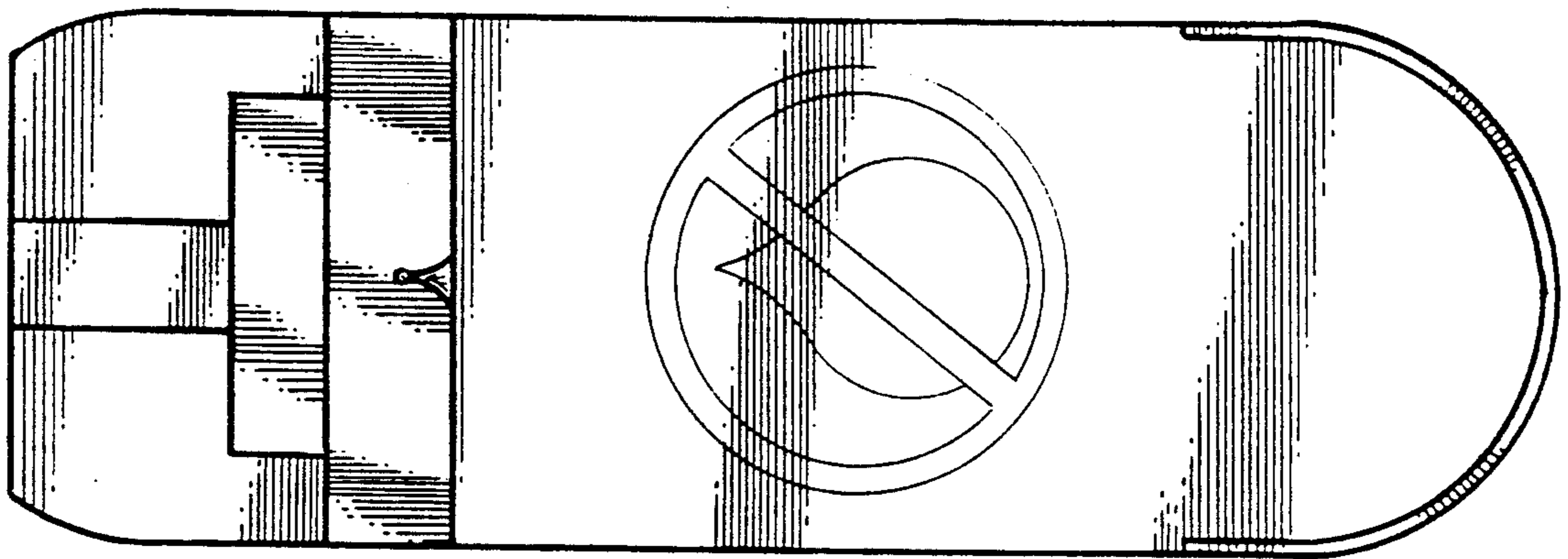

FIG. 6

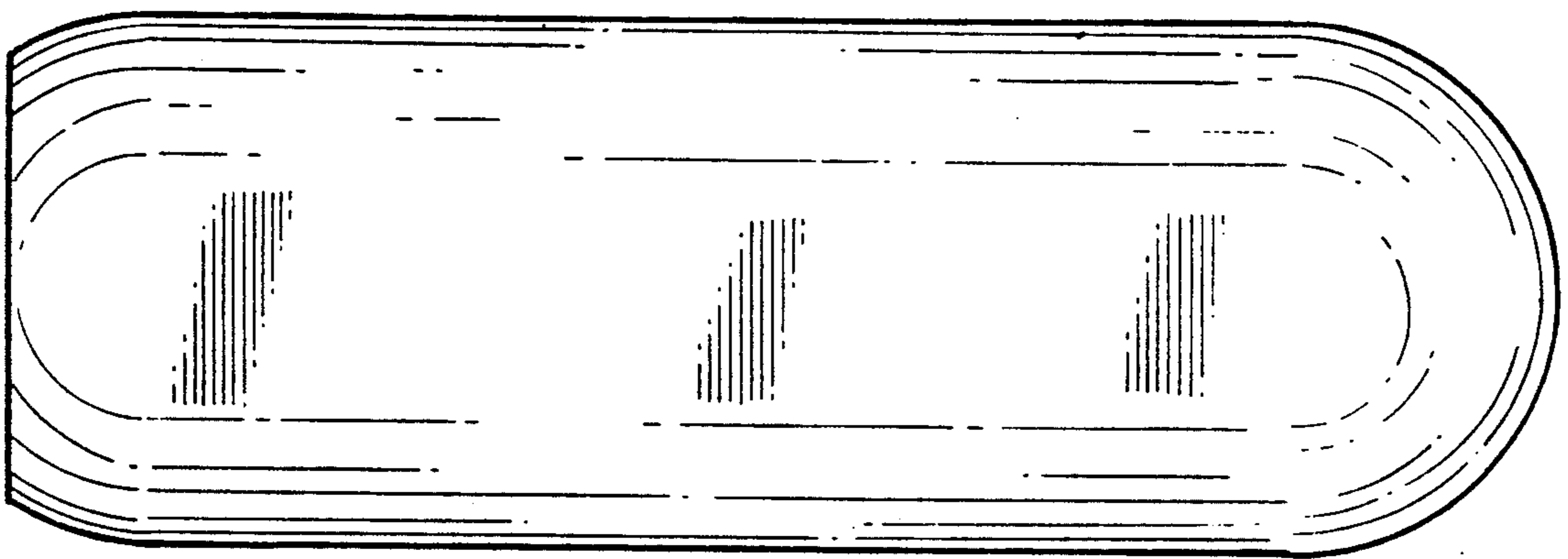

FIG. 7