



US00D342704S

United States Patent [19] Eriksson

[11] Patent Number: **Des. 342,704**

[45] Date of Patent: **** Dec. 28, 1993**

[54] STEERING BAR CLAMP

[75] Inventor: **Jan Eriksson, Östersund, Sweden**

[73] Assignee: **Aktiebolaget Electrolux, Sweden**

[**] Term: **14 Years**

[21] Appl. No.: **700,646**

[22] Filed: **May 15, 1991**

[30] Foreign Application Priority Data

Nov. 20, 1990 [SE] Sweden 902486

[52] U.S. Cl. **D12/118**

[58] Field of Search 280/279, 280; 74/551.1,
74/551.9; D12/118

[56] References Cited

U.S. PATENT DOCUMENTS

D. 298,223	10/1988	Kiyota	D12/118
D. 306,418	3/1990	McMurtrey	D12/118
4,337,962	7/1982	Allen et al.	D12/118
4,753,448	6/1988	Nagashima	280/279

OTHER PUBLICATIONS

American Bicyclist & Motorcyclist, Nov. 1989, p. 38
Tall cool one seat post.

American Bicyclist & Motorcyclist, the Campagnolo
seat post.

Primary Examiner—Wallace R. Burke

Assistant Examiner—Melody Brown

Attorney, Agent, or Firm—Pearne, Gordon, McCoy &
Granger

[57] CLAIM

The ornamental design for a steering bar clamp, as
shown.

DESCRIPTION

FIG. 1 is a top plan view of a steering bar clamp show-
ing my new design;

FIG. 2 is a front elevation view thereof;

FIG. 3 is a left side elevation view thereof;

FIG. 4 is a right side elevation view thereof;

FIG. 5 is a rear elevation view thereof;

FIG. 6 is a bottom plan view thereof; and,

FIG. 7 is a top and rear perspective view thereof.

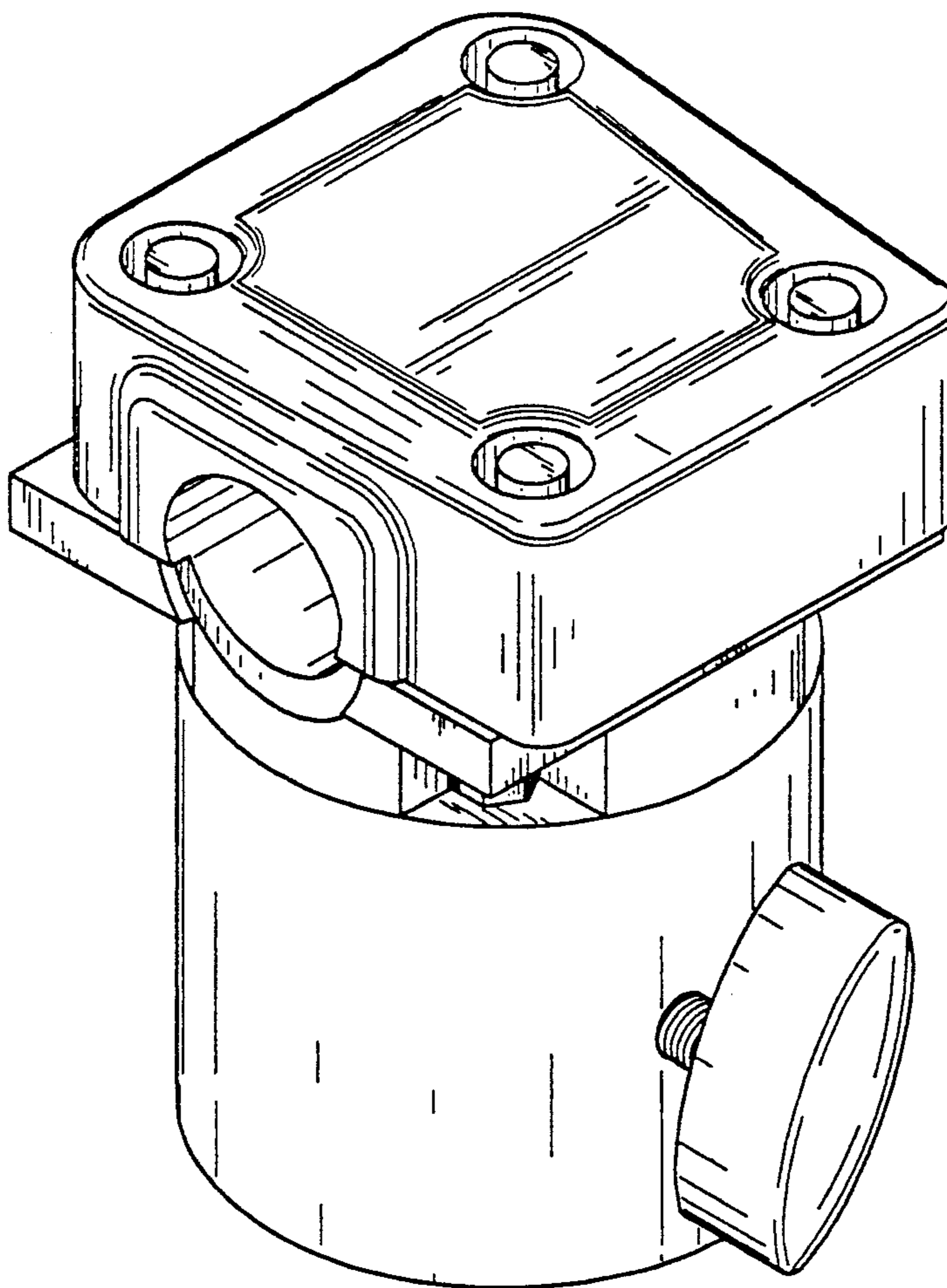

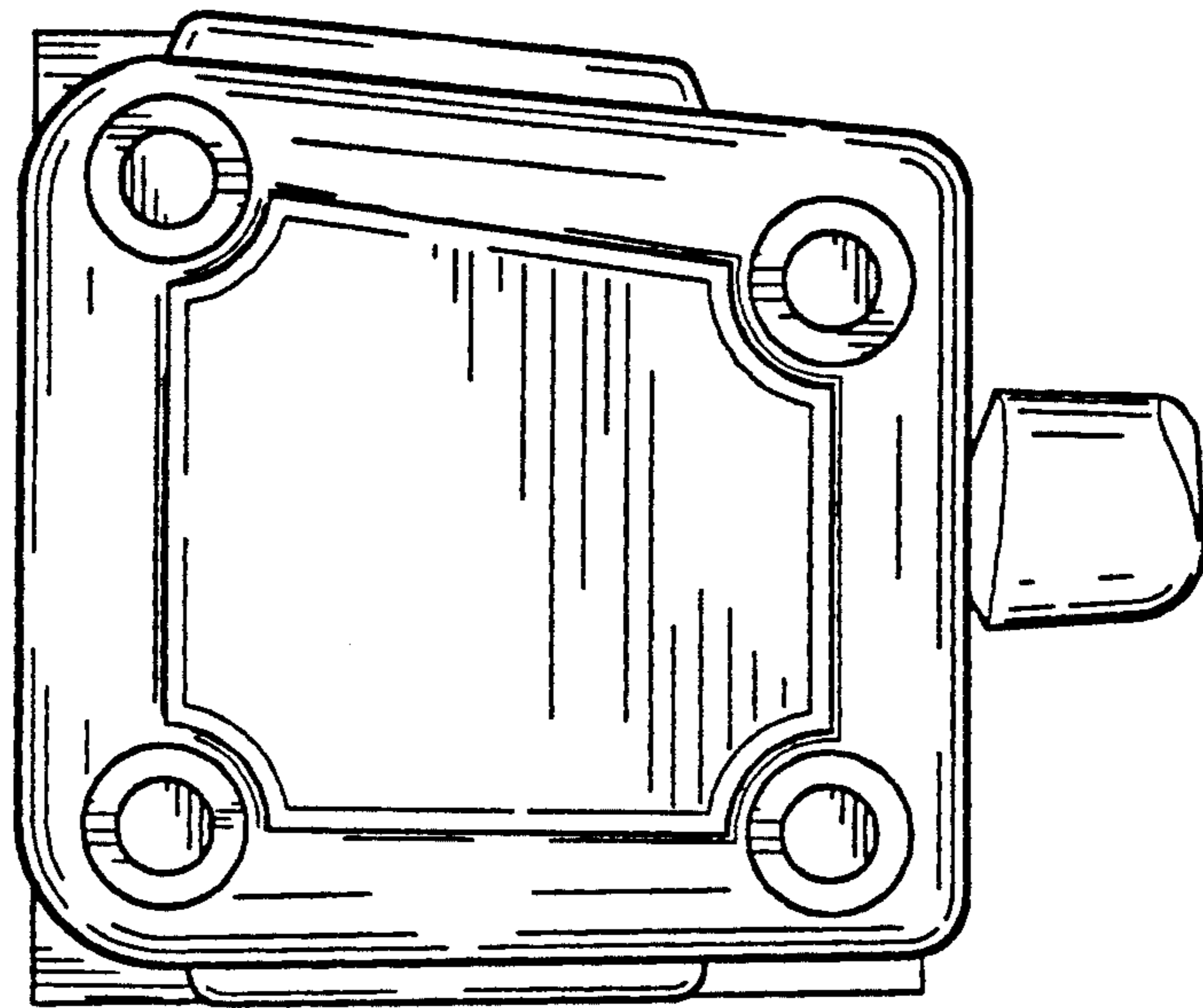

Fig.1

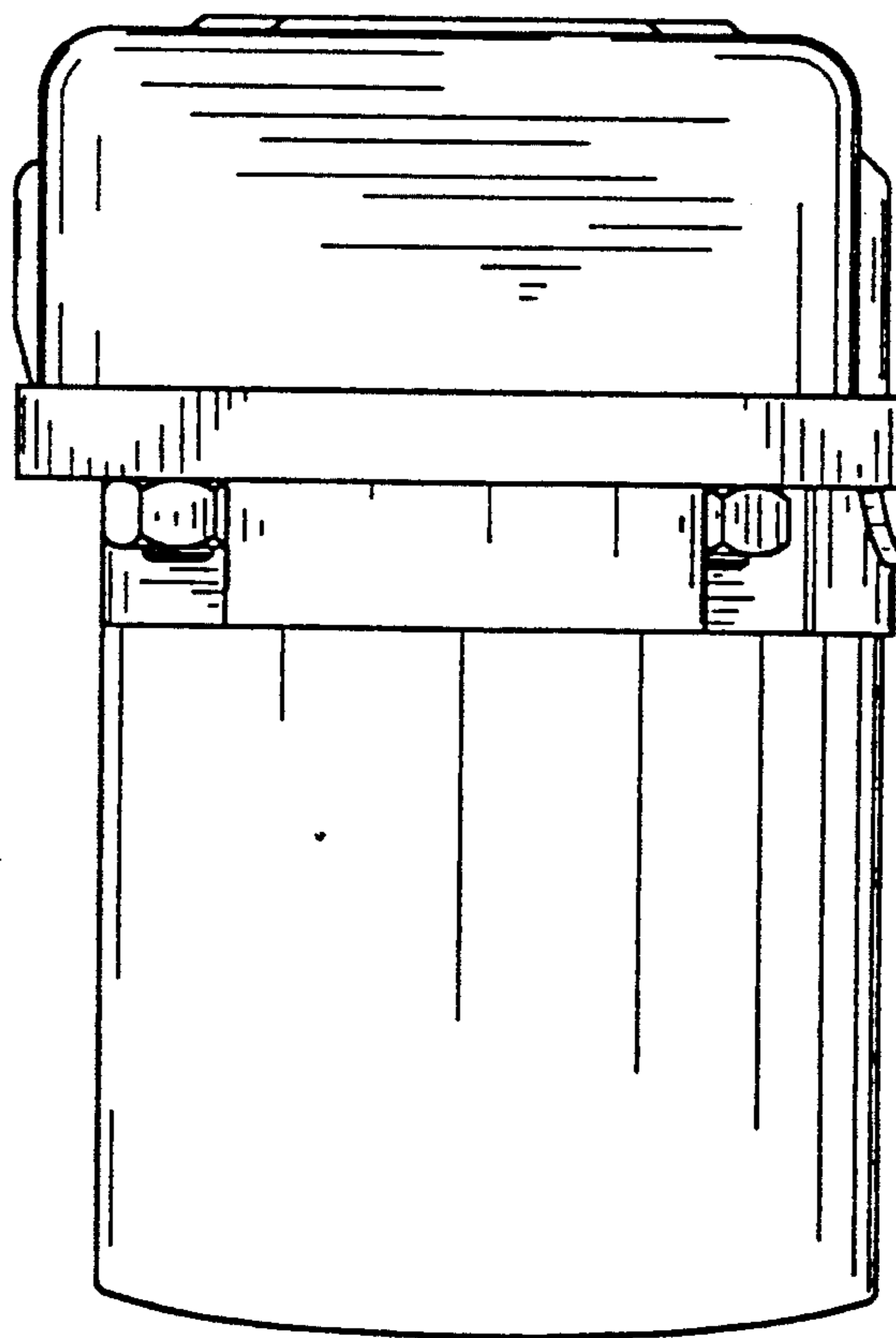

Fig.2

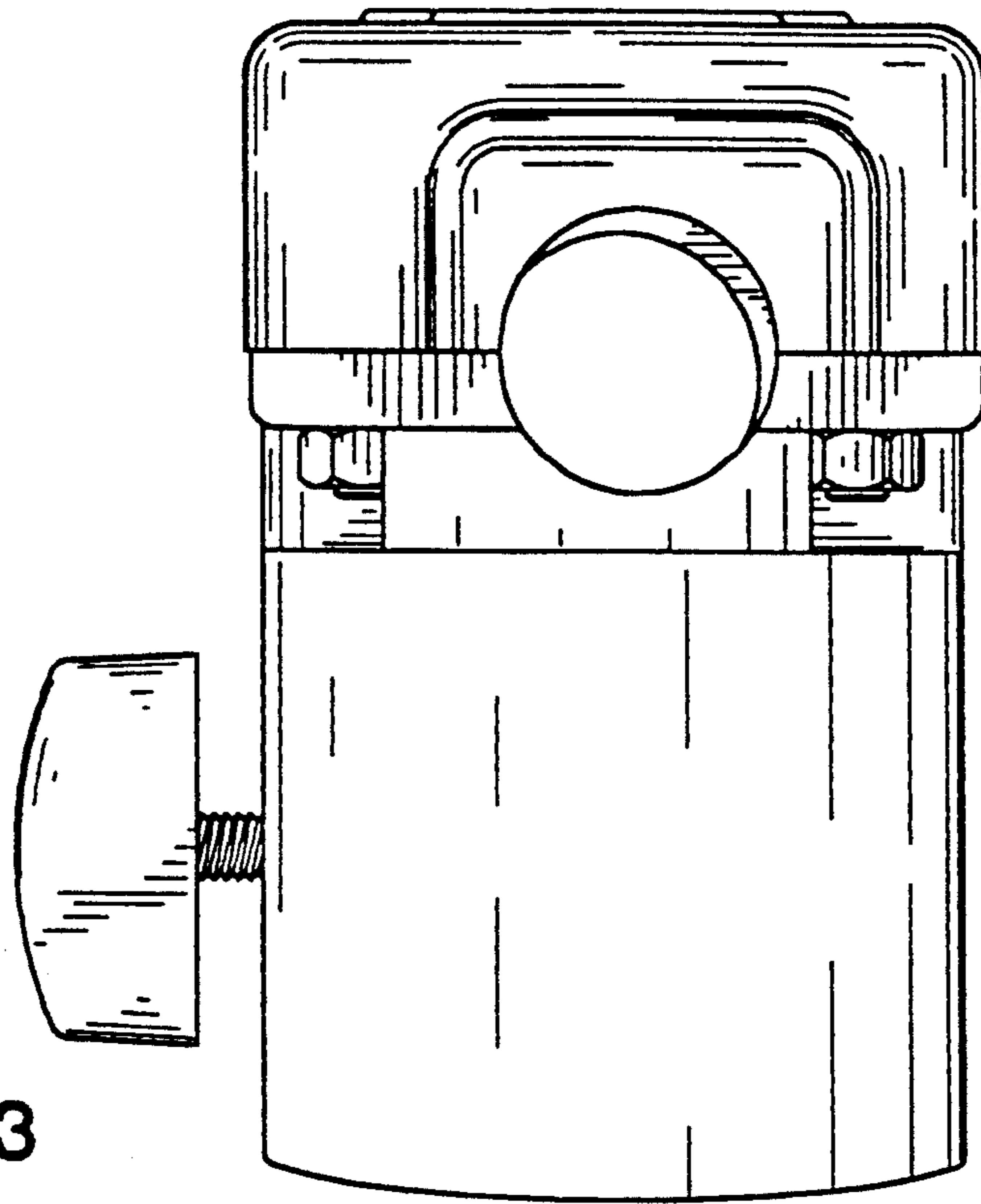

Fig.3

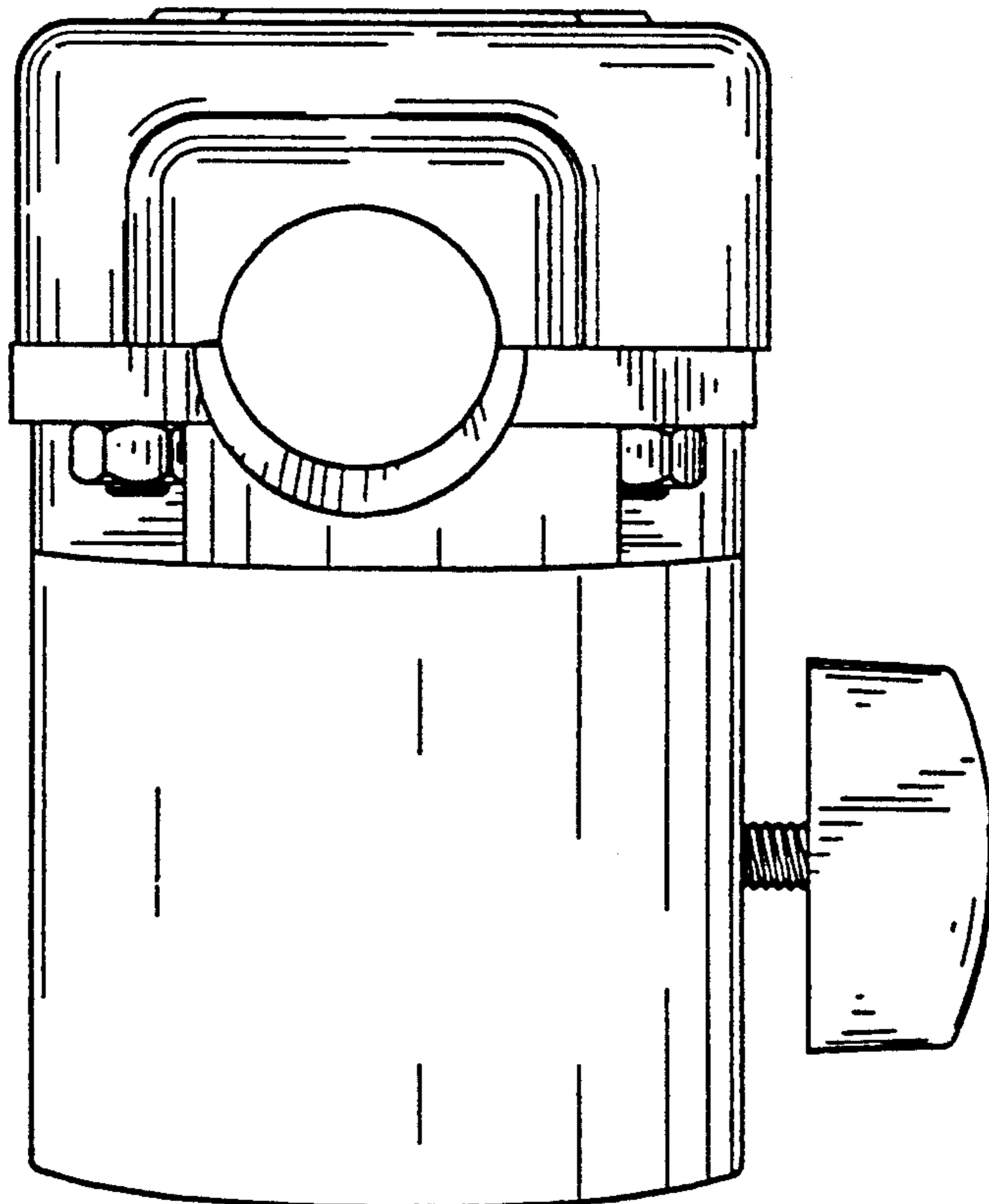

Fig.4

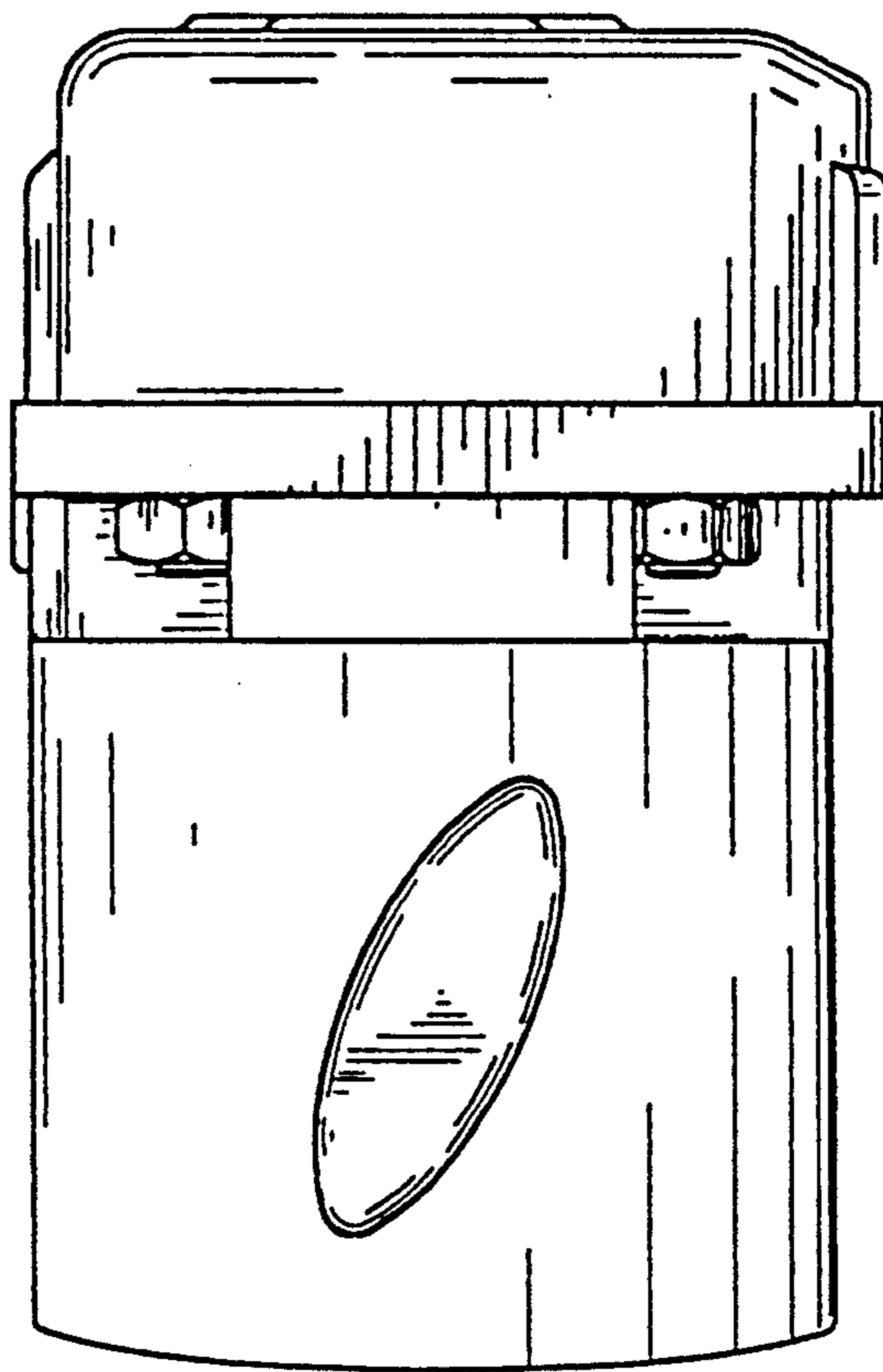

Fig.5

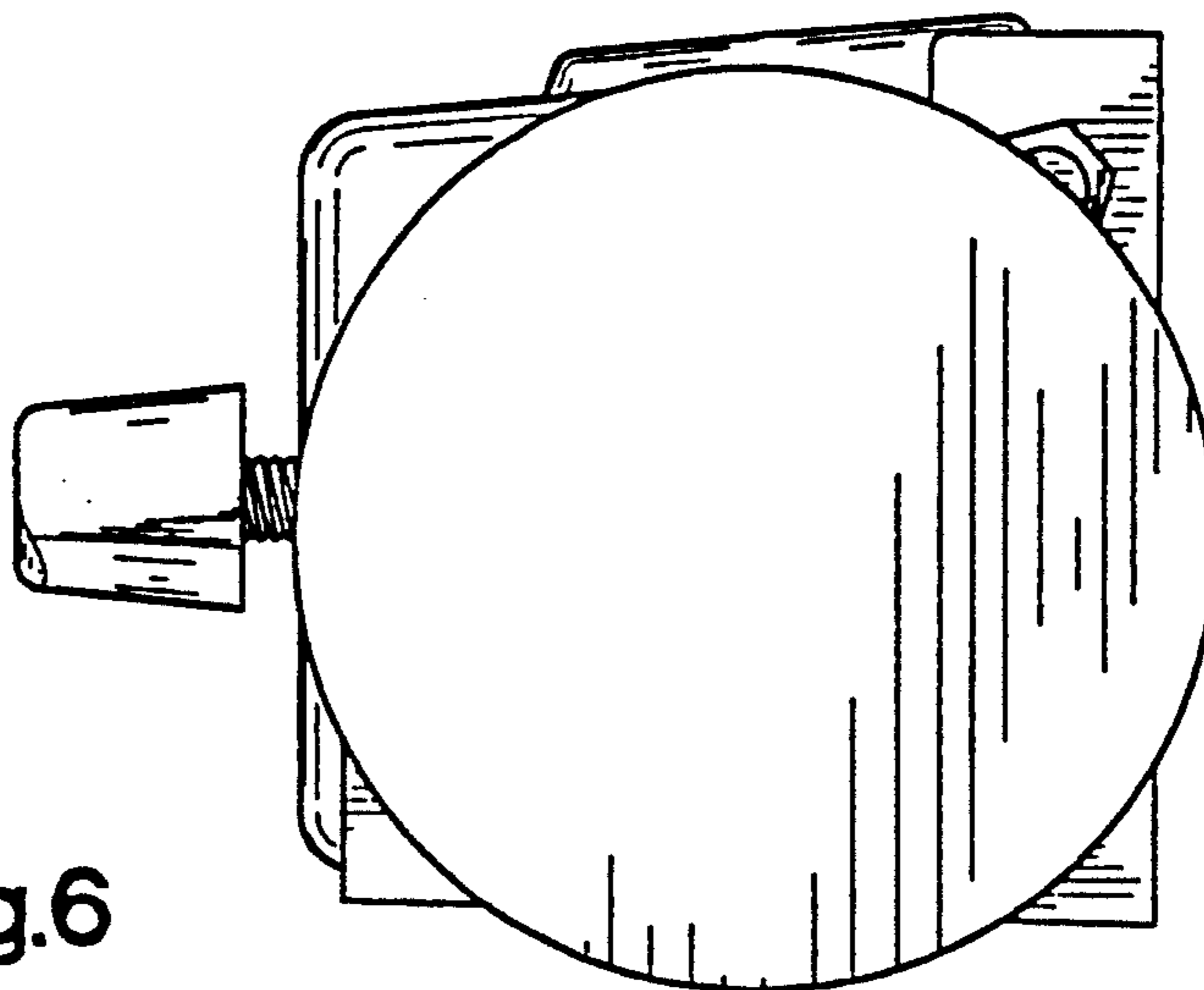

Fig.6

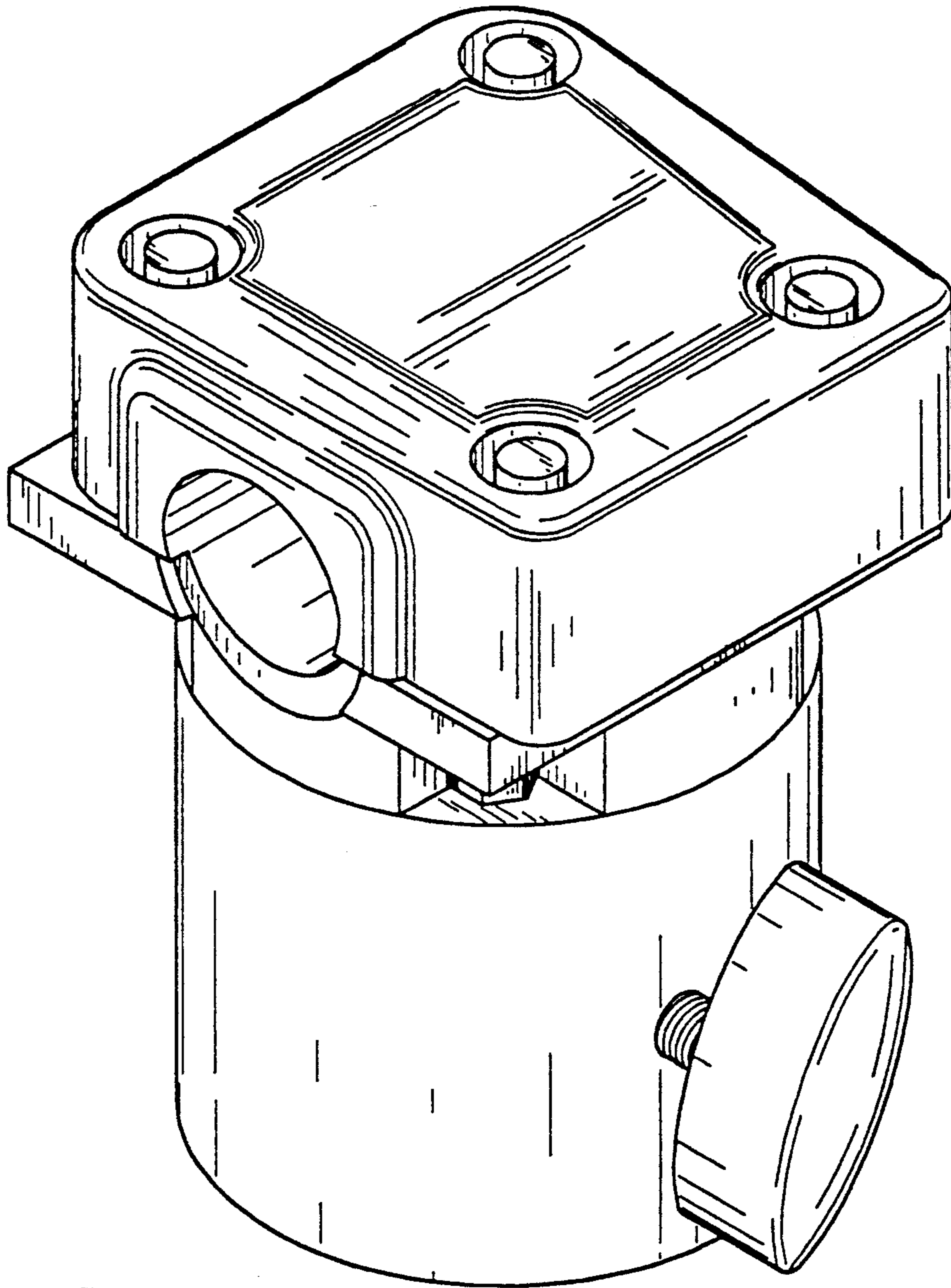

Fig.7