



US00D342702S

United States Patent [19]

[11] Patent Number: **Des. 342,702**

Camfield et al.

[45] Date of Patent: **** Dec. 28, 1993**

[54] **BICYCLE**

[75] Inventors: **David K. Camfield; Duane Niemeyer,**
both of Olney, Ill.

[73] Assignee: **Roadmaster Corporation,** Olney, Ill.

[**] Term: **14 Years**

[21] Appl. No.: **896,558**

[22] Filed: **Jun. 10, 1992**

[52] U.S. Cl. **D12/111**

[58] Field of Search **D12/111, 110;**
280/281.1, 288.1, 288.2, 288.3

[56] **References Cited**

U.S. PATENT DOCUMENTS

D. 93,008	5/1934	Ely	D12/111
D. 138,304	7/1944	Boynton	D12/111
D. 149,408	4/1948	Fuhs	D12/111
D. 166,693	9/1951	Lines	D12/111
D. 170,610	10/1953	Sebel	D12/111
D. 203,146	12/1965	Ryan	D12/111
D. 237,701	11/1975	Vachon	D12/111
D. 240,418	7/1976	Hirano et al.	D12/111
D. 245,002	7/1977	Carpenter et al.	D12/111
D. 246,170	10/1977	Powers	D12/111
D. 246,779	12/1977	Cognata	D12/126
D. 250,329	11/1978	Breen	D12/126
D. 267,560	1/1983	Matsue	D12/110
D. 270,047	8/1983	Kataoka et al.	D12/110
D. 273,100	3/1984	Ziegler	D12/111
D. 273,854	5/1984	Ishiyama	D12/110
D. 275,469	9/1984	Morioka et al.	D12/110
D. 291,187	8/1987	Smith et al.	D12/111
D. 291,291	8/1987	Voytko et al.	D12/111
D. 291,292	8/1987	Smith et al.	D12/111
D. 294,338	2/1988	Yamada et al.	D12/110
D. 295,274	4/1988	Matsuzaki et al.	D12/110
D. 299,016	12/1988	Kitagawa et al.	D12/110
D. 299,447	1/1989	Sakuma et al.	D12/110
D. 299,816	2/1989	Maruyama et al.	D12/110
D. 311,507	10/1990	Sasaki et al.	D12/110
D. 312,807	12/1990	Kohama et al.	D12/110
D. 313,380	1/1991	Imai et al.	D12/110
D. 314,167	1/1991	Kolter et al.	D12/110
D. 321,849	11/1991	Abe et al.	D12/110
D. 326,247	5/1992	Hess	D12/111
1,498,677	6/1924	Bemis et al.	280/288.1

OTHER PUBLICATIONS

Brochure, Honda "1991 VFR750F".

Brochure, Honda "1991 CBR600F2".

Brochure, Honda "1991 XR200R, XR100R, XR80R and Z50R".

Catalogue, AMF, Evel Knievel Line, Spirited New Evel Knievel Styles for 1976 (See models L-9240, E-992, E-966).

Catalogue, AMF, Junior, 1977 Juvenile Wheel Goods, (See models G-992, G-986).

Catalogue, AMF, Roadmaster, Bicycles for 1977 (See models M-9224, M-9226, M-9236, M-9234).

Catalogue, AMF, 1978 Juvenile Wheel Goods (See models A-992, A-905).

Catalogue, AMF, Roadmaster, Bicycles for 1978 (See models P-9240, P-9216, P-9234, P-9214).

Catalogue, AMF, Junior, Wheel Goods for 1979 (See model B-905).

Catalogue, AMF, Roadmaster, Bicycles for 1979 (See models R-9214, R-9234, R-9238).

Catalogue, Bicycles for 1975 (See model K-9234).

Catalogue, AMF, Junior, 1976 Juvenile Wheel Goods (see model E-986).

Catalogue, AMF, Roadmaster, Bicycle for 1976 (See models L-9230, L-9234, L-9238, L-9236).

Primary Examiner—Wallace R. Burke

Assistant Examiner—Melody Brown

Attorney, Agent, or Firm—Willian Brinks Olds Hofer Gilson & Lione

[57] **CLAIM**

The ornamental design for a bicycle, as shown and described.

DESCRIPTION

FIG. 1 is a left, front perspective view of a bicycle showing the new design;

FIG. 2 is a left side elevational view thereof;

FIG. 3 is a right side elevational view thereof;

FIG. 4 is a front elevational view thereof;

FIG. 5 is a rear elevational view thereof;

FIG. 6 is a top plan view thereof;

FIG. 7 is a bottom plan view thereof;

FIG. 8 is a left, front perspective view of a bicycle showing a second embodiment of the new design;

FIG. 9 is a left side elevational view thereof;

FIG. 10 is a front elevational view thereof;

FIG. 11 is a right side elevational view thereof;

FIG. 12 is a rear elevational view thereof;

FIG. 13 is a top plan view thereof; and,

FIG. 14 is a bottom plan view thereof.

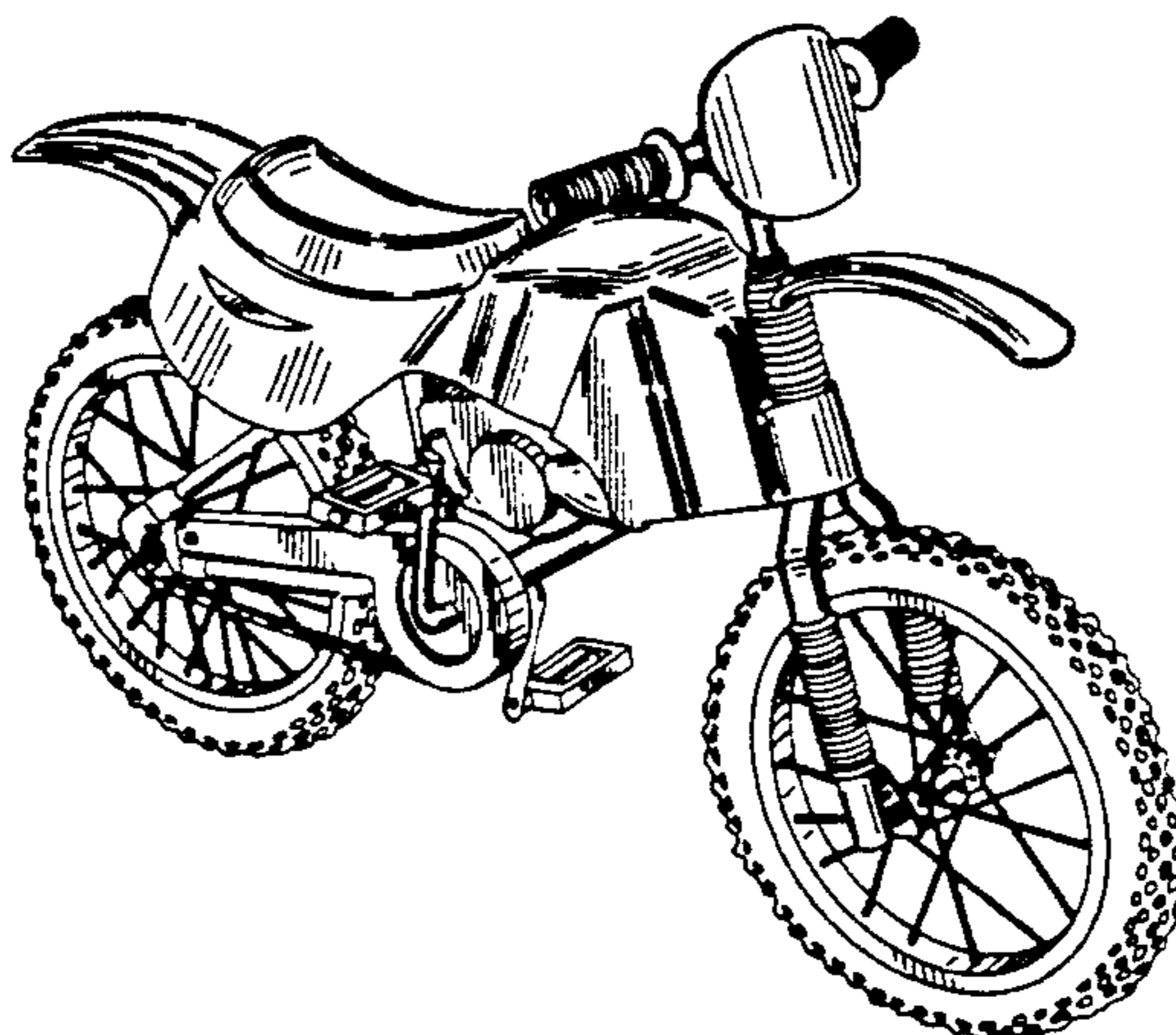
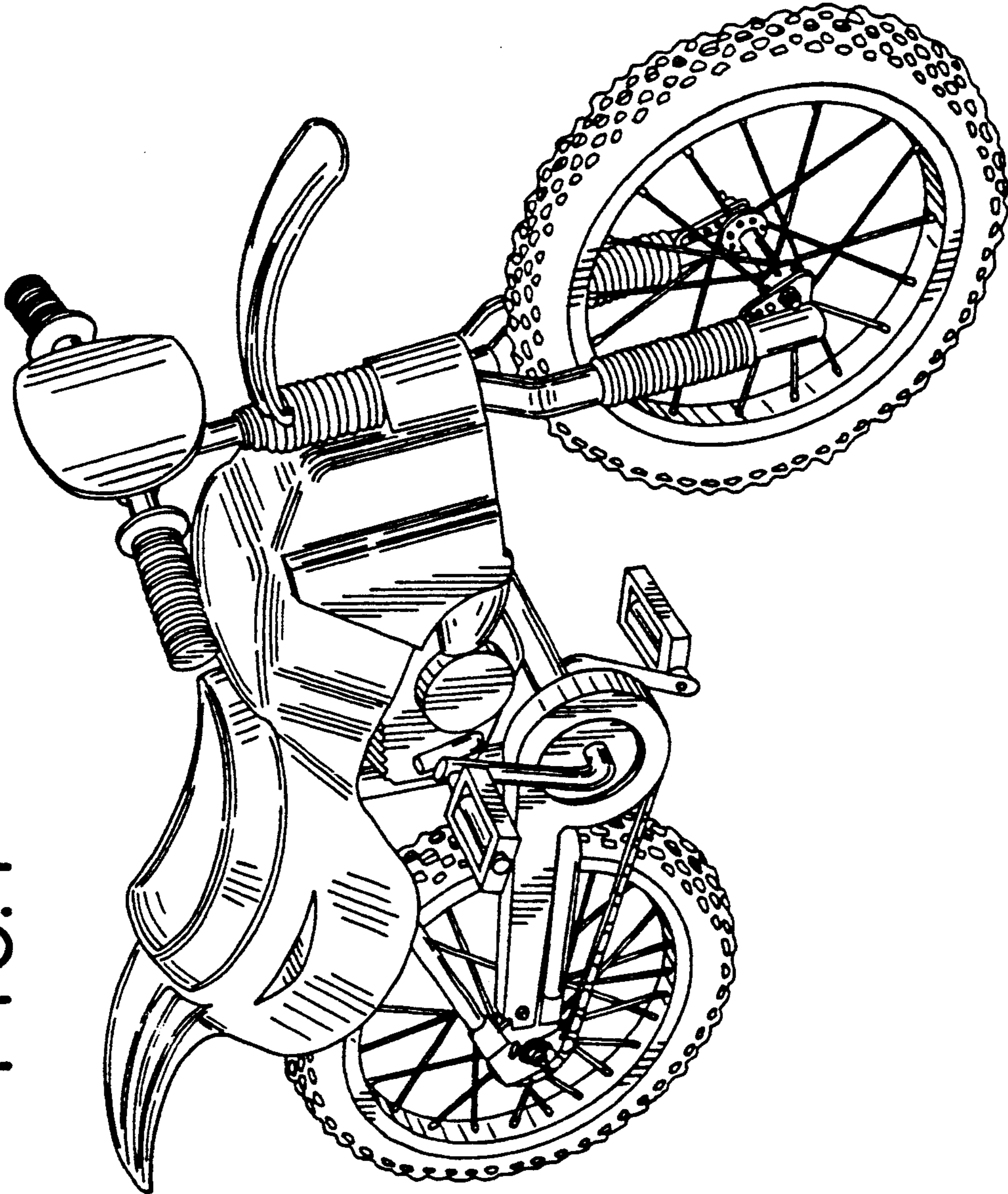

FIG. 1



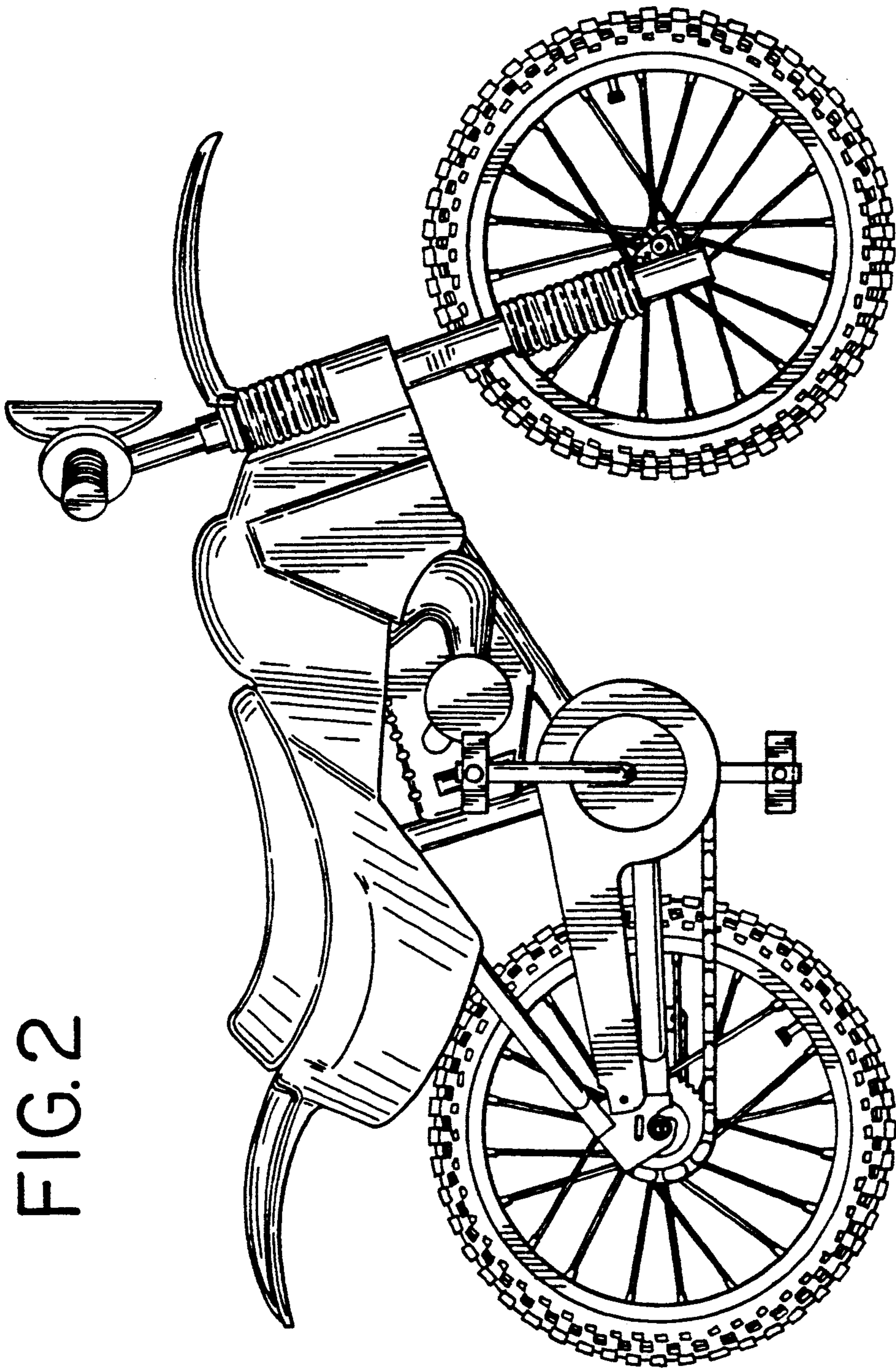

FIG. 2

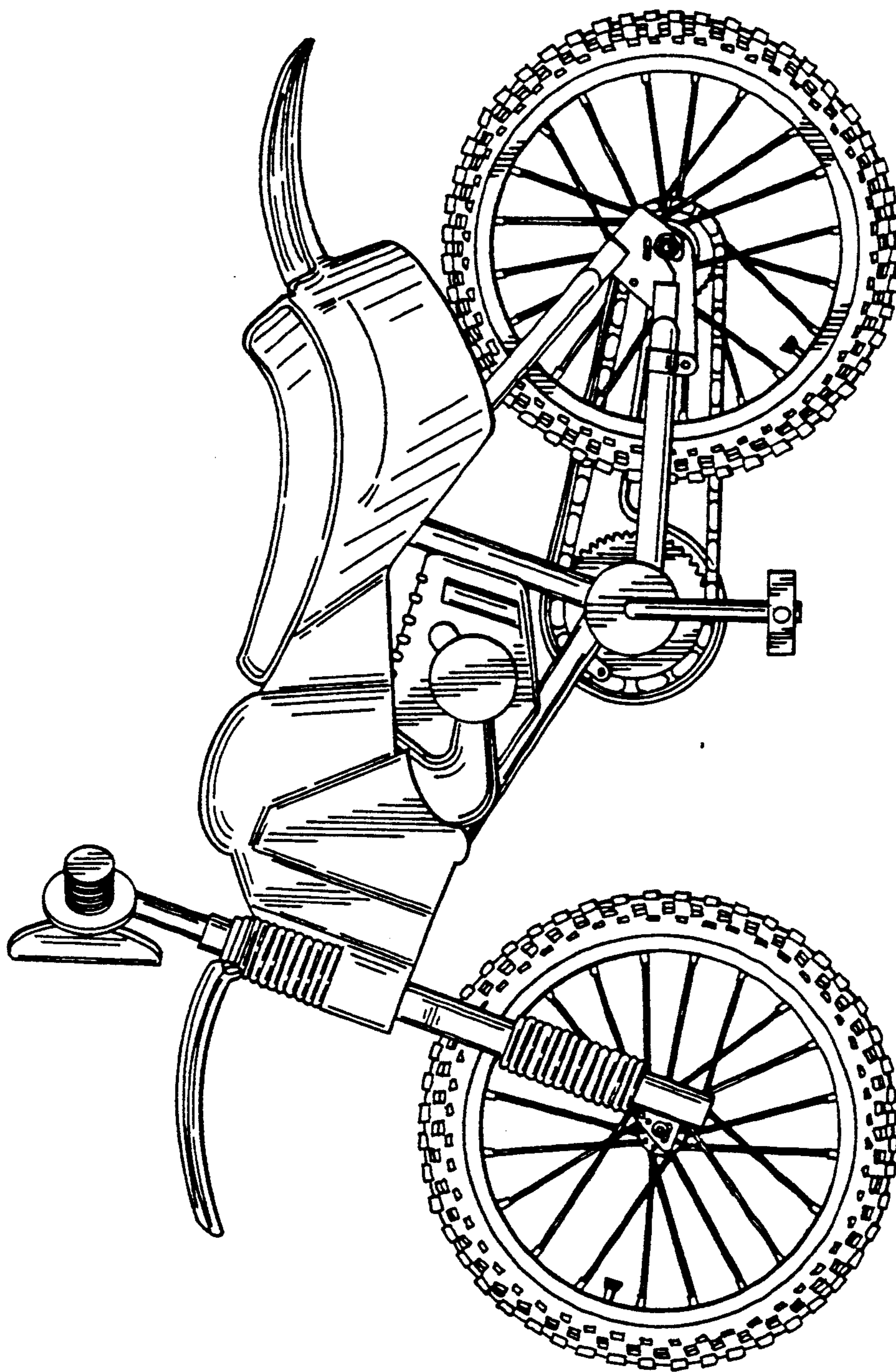

FIG. 3

FIG. 5

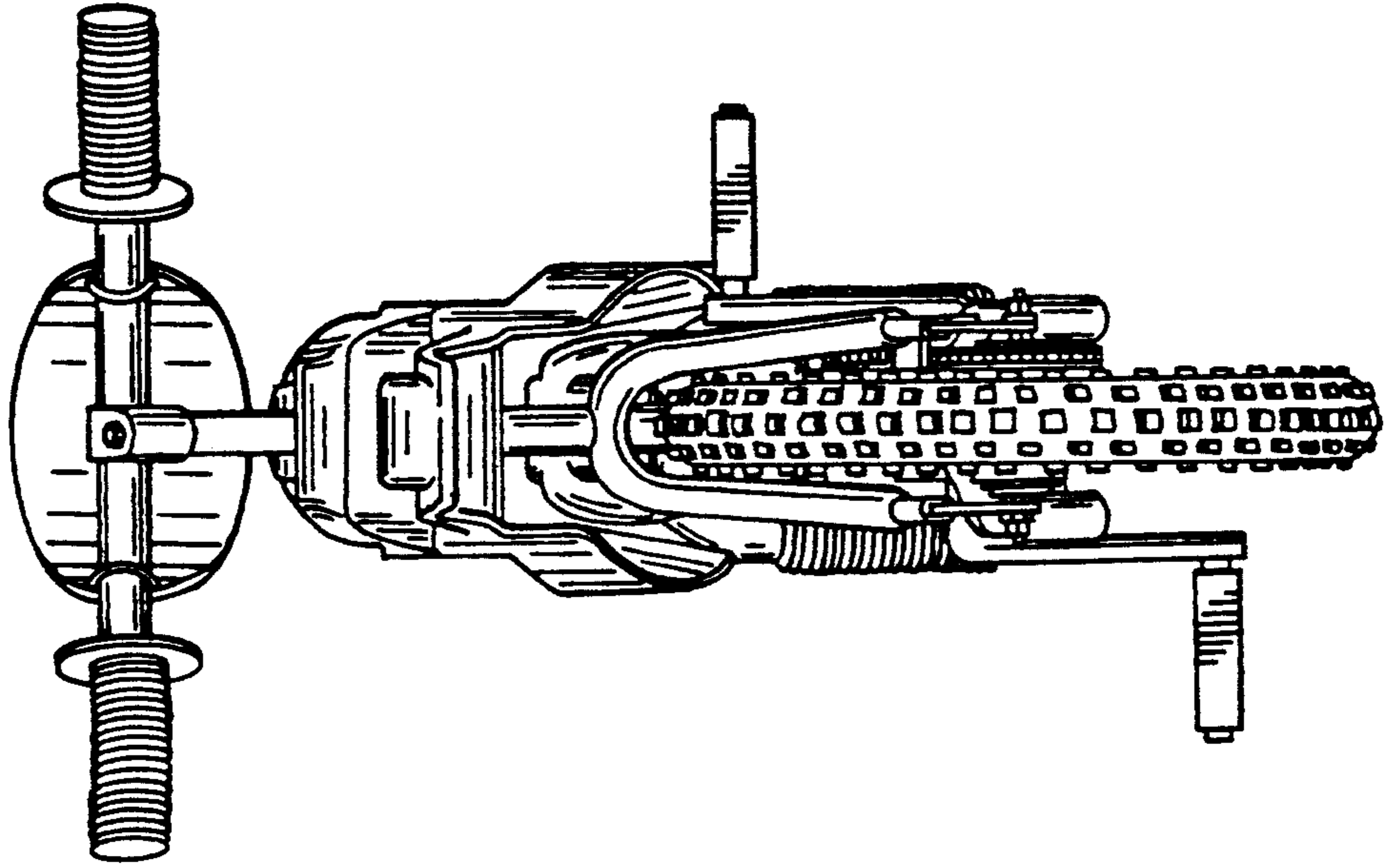

FIG. 4

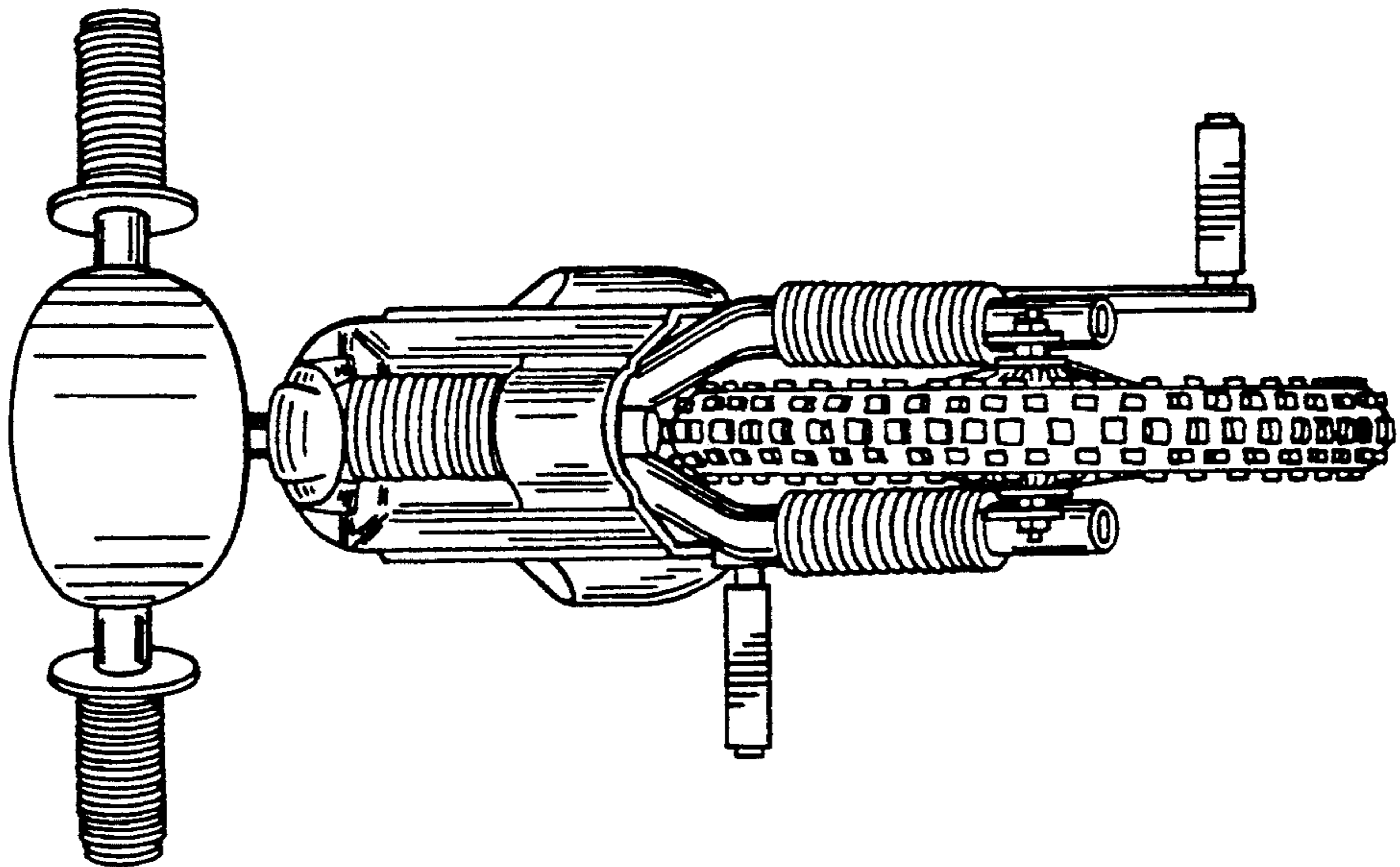

FIG. 6

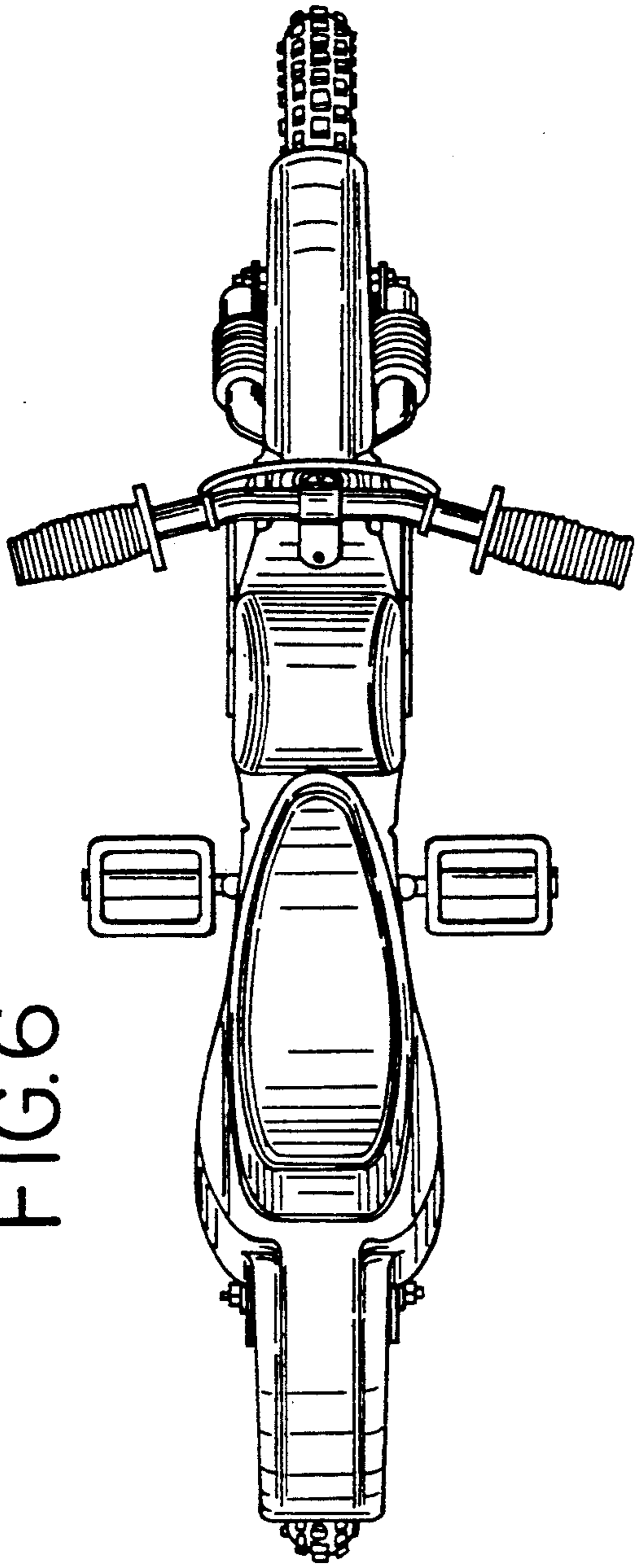

FIG. 7

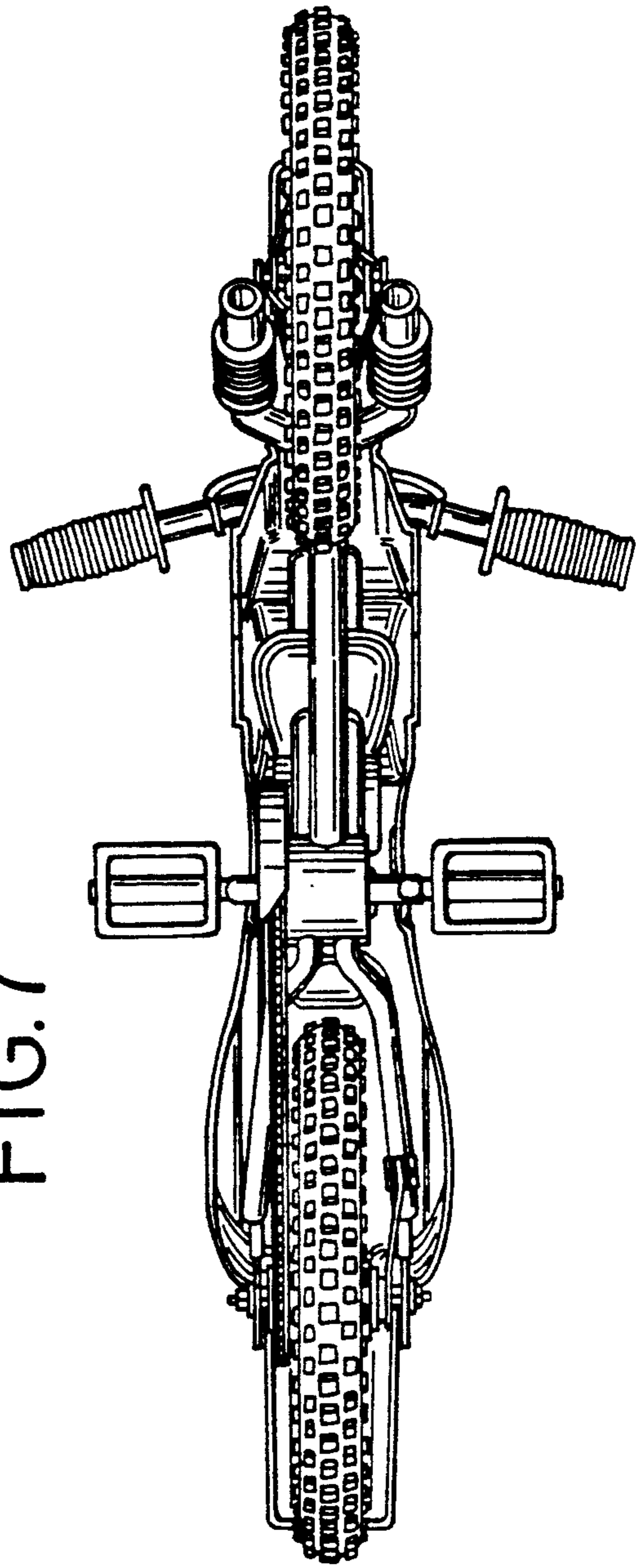

FIG. 8

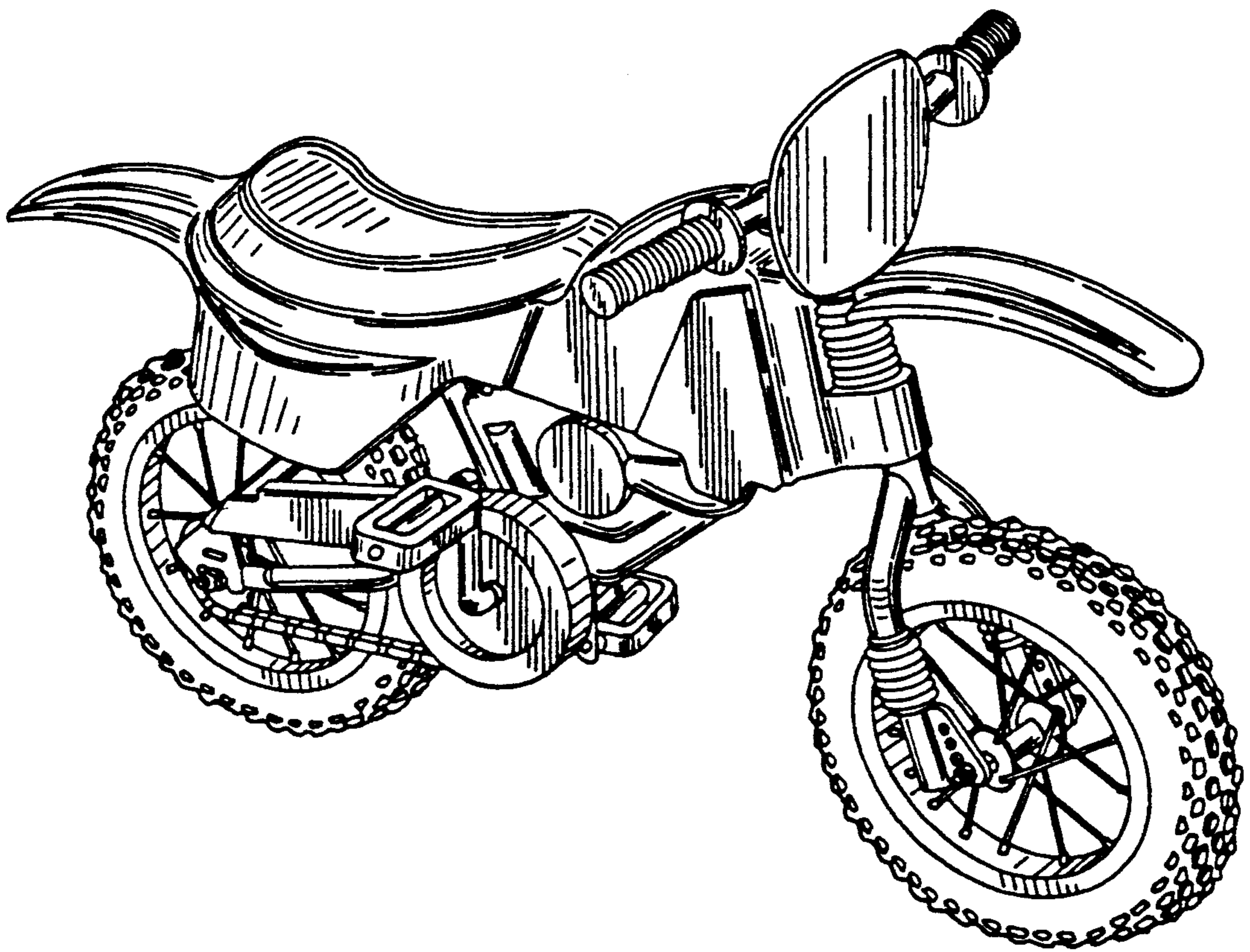

FIG. 10

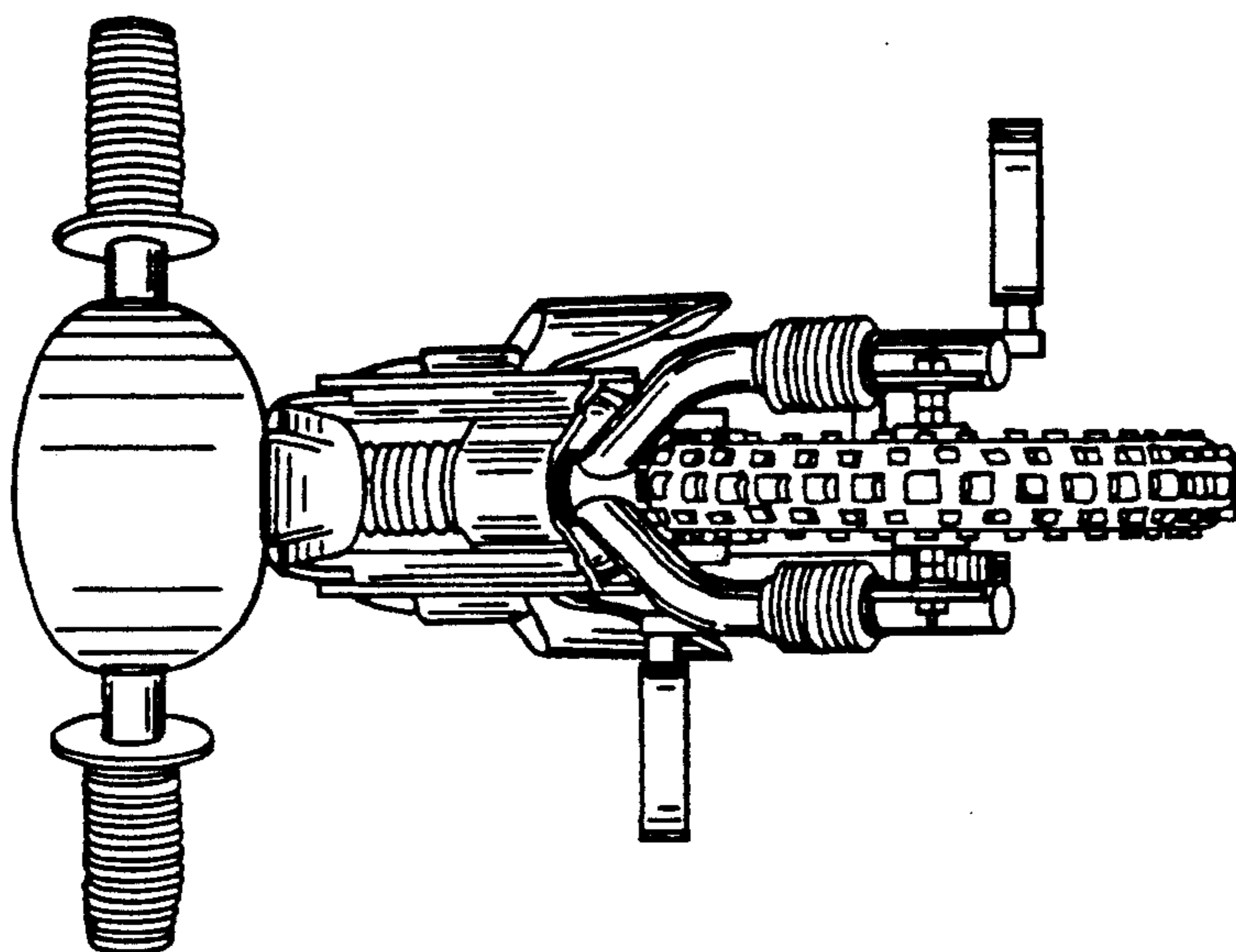

FIG. 9

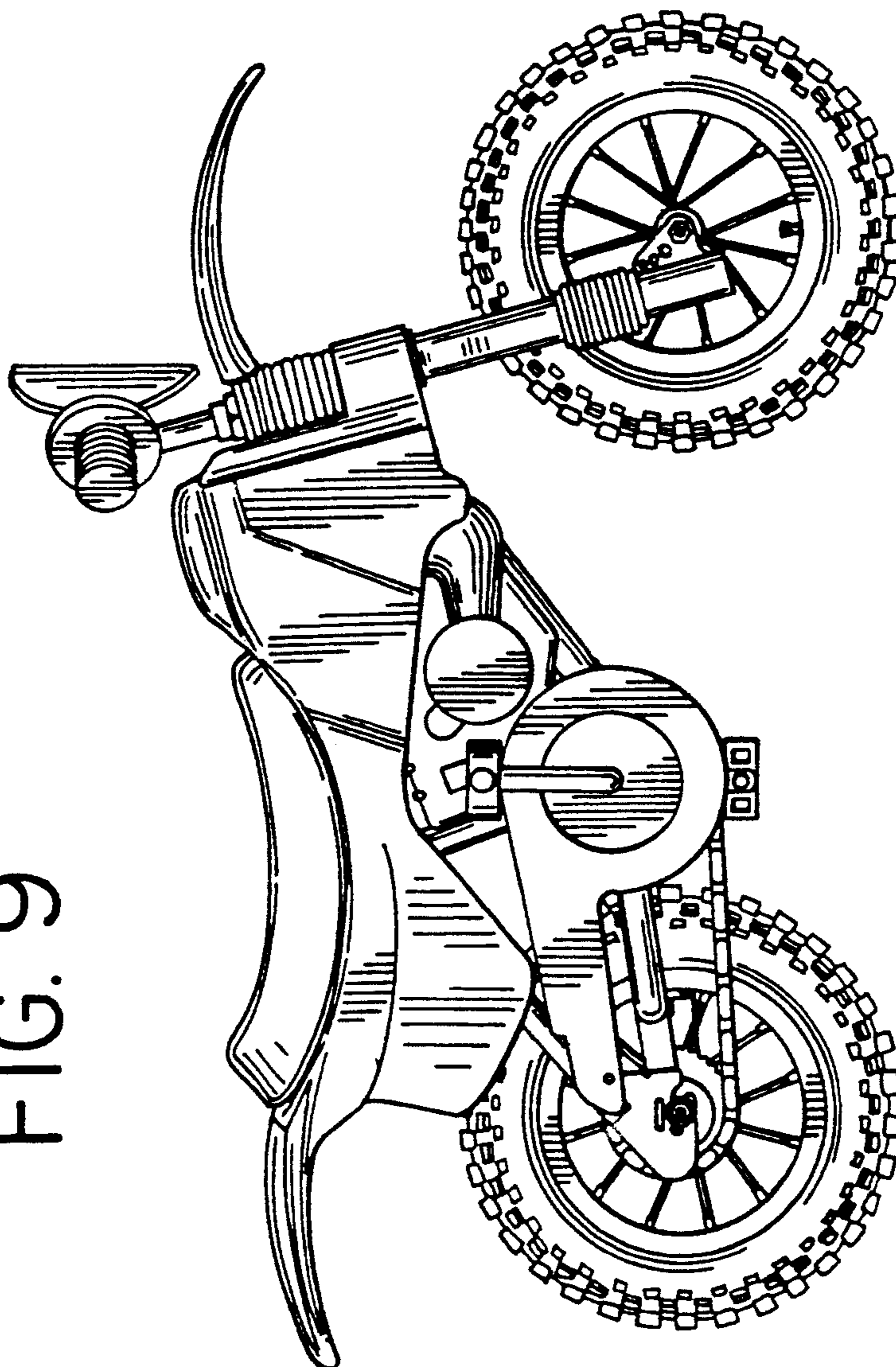

FIG. 12

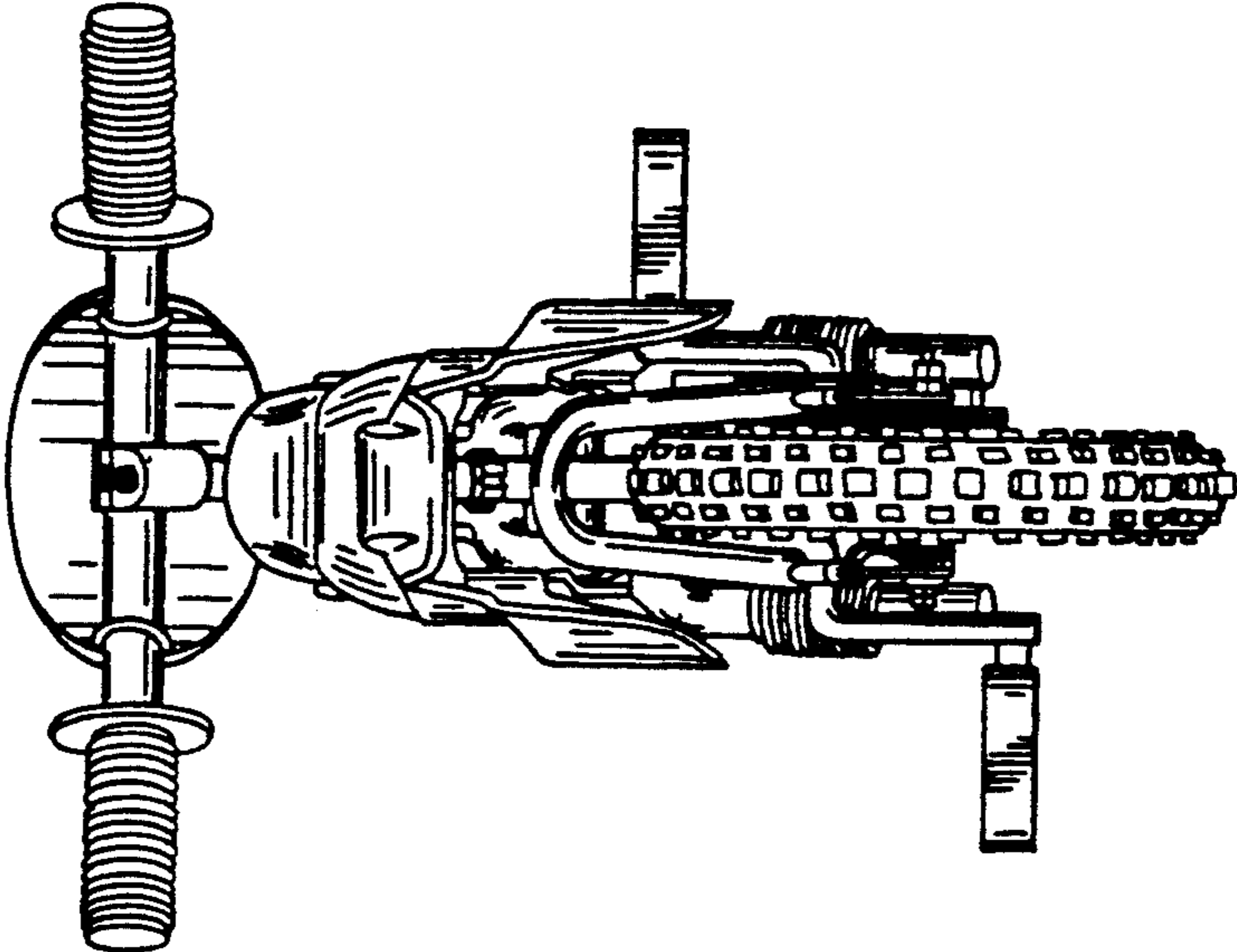

FIG. 11

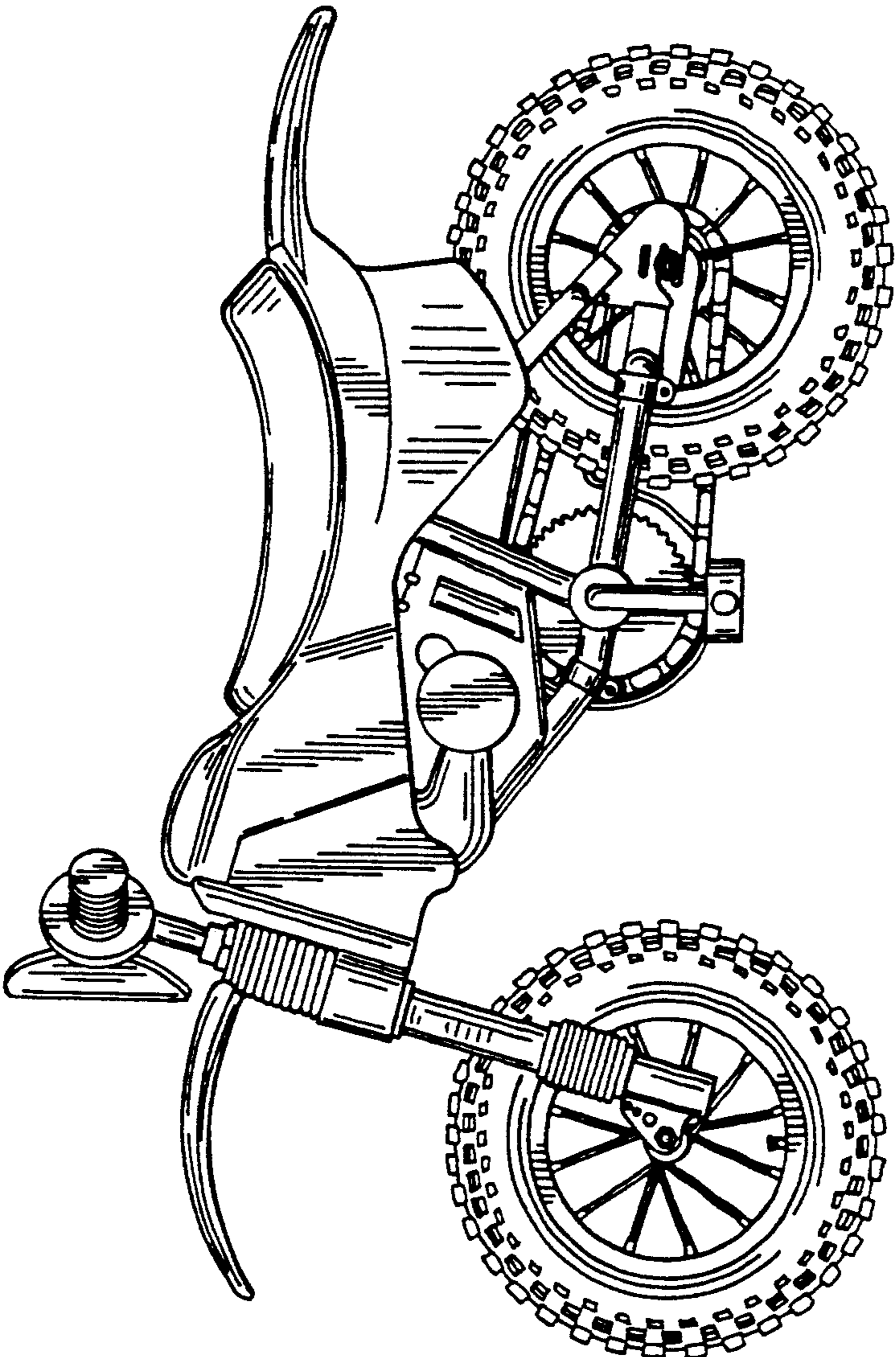

FIG. 13

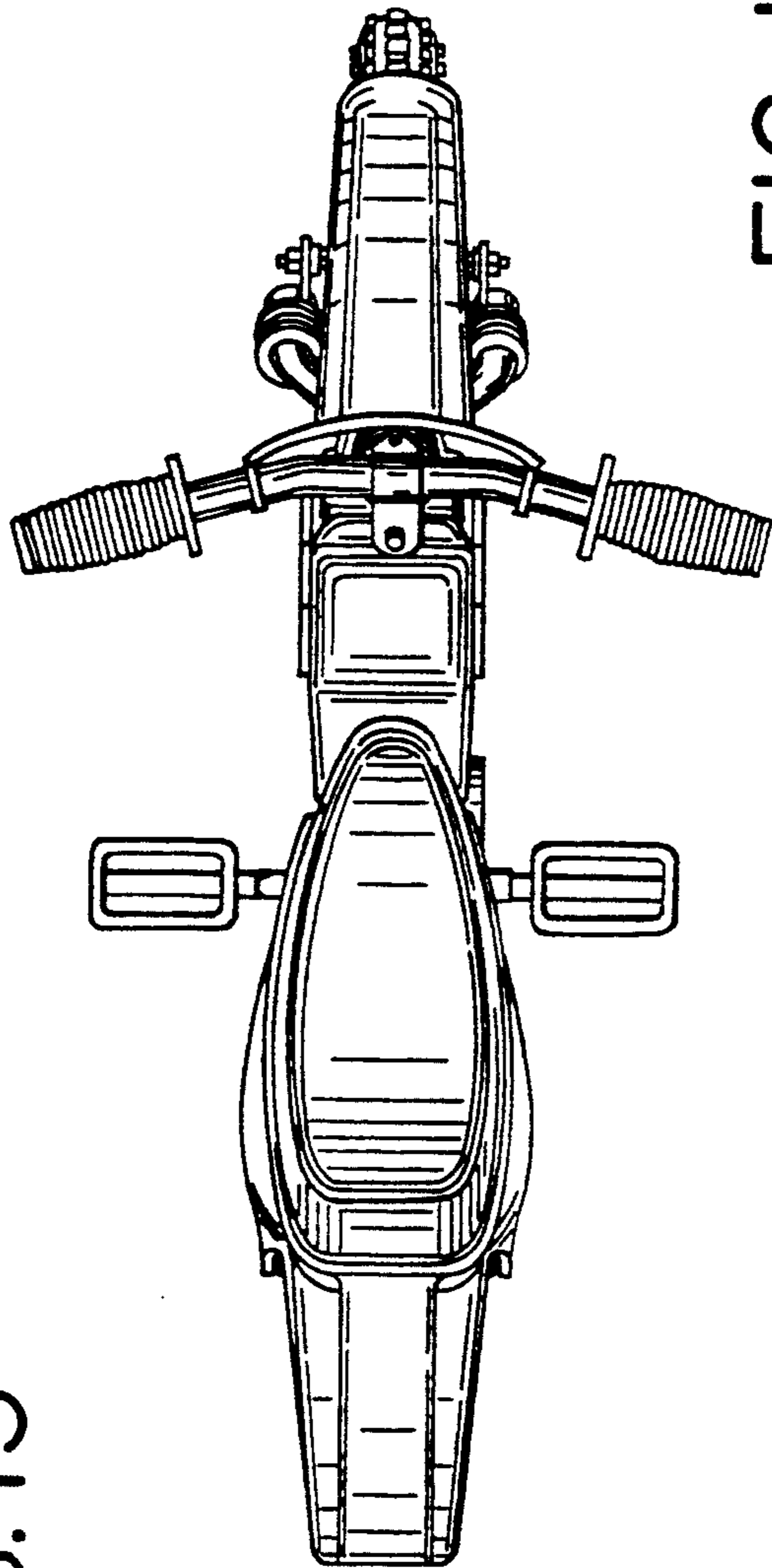

FIG. 14

