



US00D342701S

United States Patent [19]

[11] Patent Number: Des. 342,701

Murata et al.

[45] Date of Patent: ** Dec. 28, 1993

[54] 4-WHEELED VEHICLE

[75] Inventors: Yutaka Murata, Fujimi; Kazuhiko Yokoyama, Kawagoe, both of Japan

[73] Assignee: Honda Giken Kogyo Kabushiki Kaisha, Tokyo, Japan

[**] Term: 14 Years

[21] Appl. No.: 756,107

[22] Filed: Sep. 6, 1991

[30] Foreign Application Priority Data

Jun. 4, 1991 [JP] Japan 3-6316

[52] U.S. Cl. D12/107; D12/1

[58] Field of Search D12/1, 14, 16, 107; 280/756; 180/22, 24.01, 24.11; 414/460

[56] References Cited

U.S. PATENT DOCUMENTS

D. 292,899 11/1987 Samuelson et al. D12/16
D. 299,323 1/1989 page D12/14

D. 332,239 1/1993 Hiratap et al. D12/1
4,153,262 5/1979 Diamond 280/756
4,946,193 8/1990 Oka D12/14

FOREIGN PATENT DOCUMENTS

65202579 12/1988 Japan .

Primary Examiner—Wallace R. Burke
Assistant Examiner—Melody Brown
Attorney, Agent, or Firm—Armstrong, Westerman, Hattori, McLeland & Naughton

[57] CLAIM

The ornamental design for a 4-wheeled vehicle, as shown.

DESCRIPTION

FIG. 1 is a top view of a 4-wheeled vehicle showing my new design;
FIG. 2 is a rear view thereof;
FIG. 3 is a right side view thereof;
FIG. 4 is a front view thereof;
FIG. 5 is a left side view thereof; and,
FIG. 6 is a bottom view thereof.

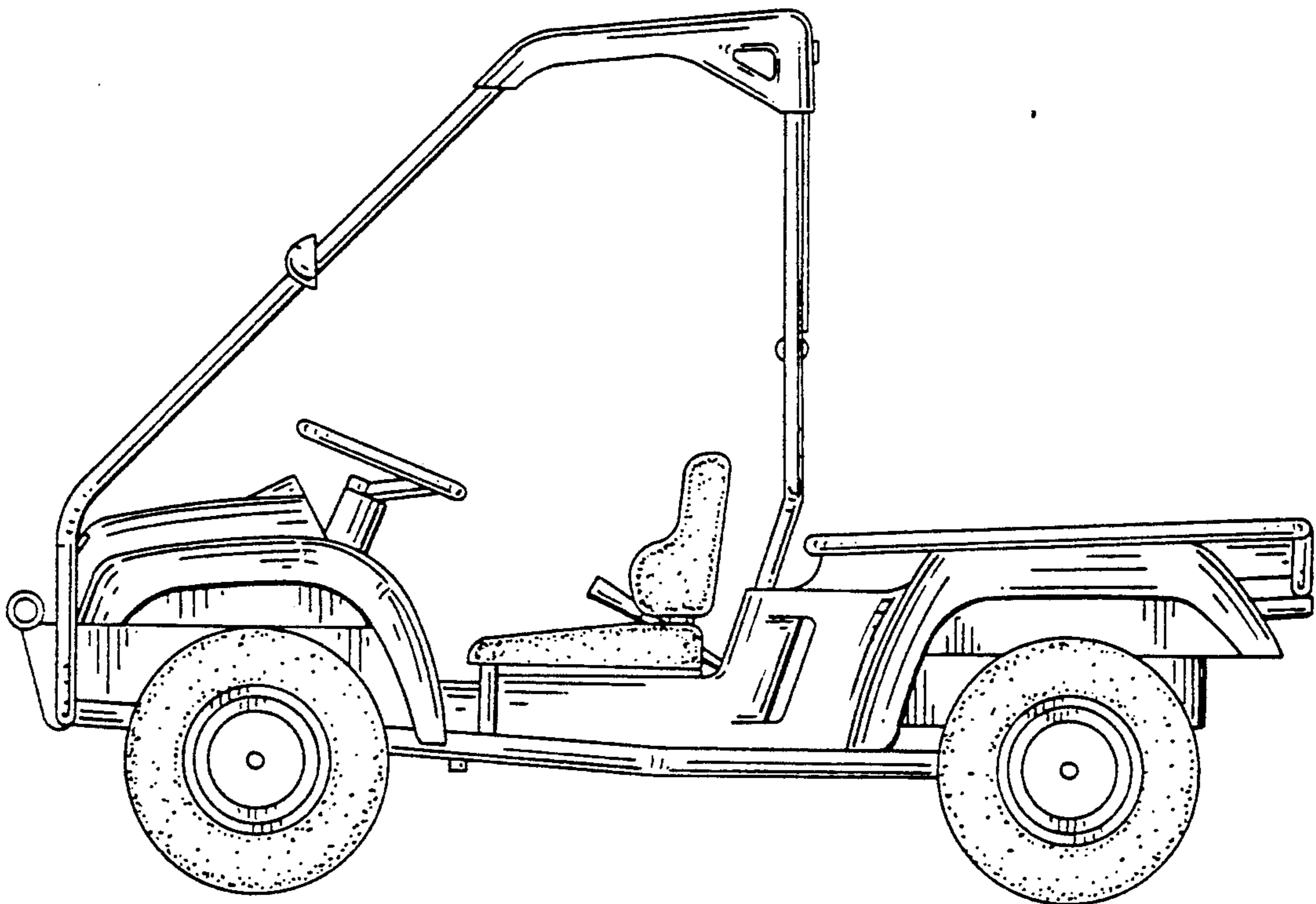

FIG. 1

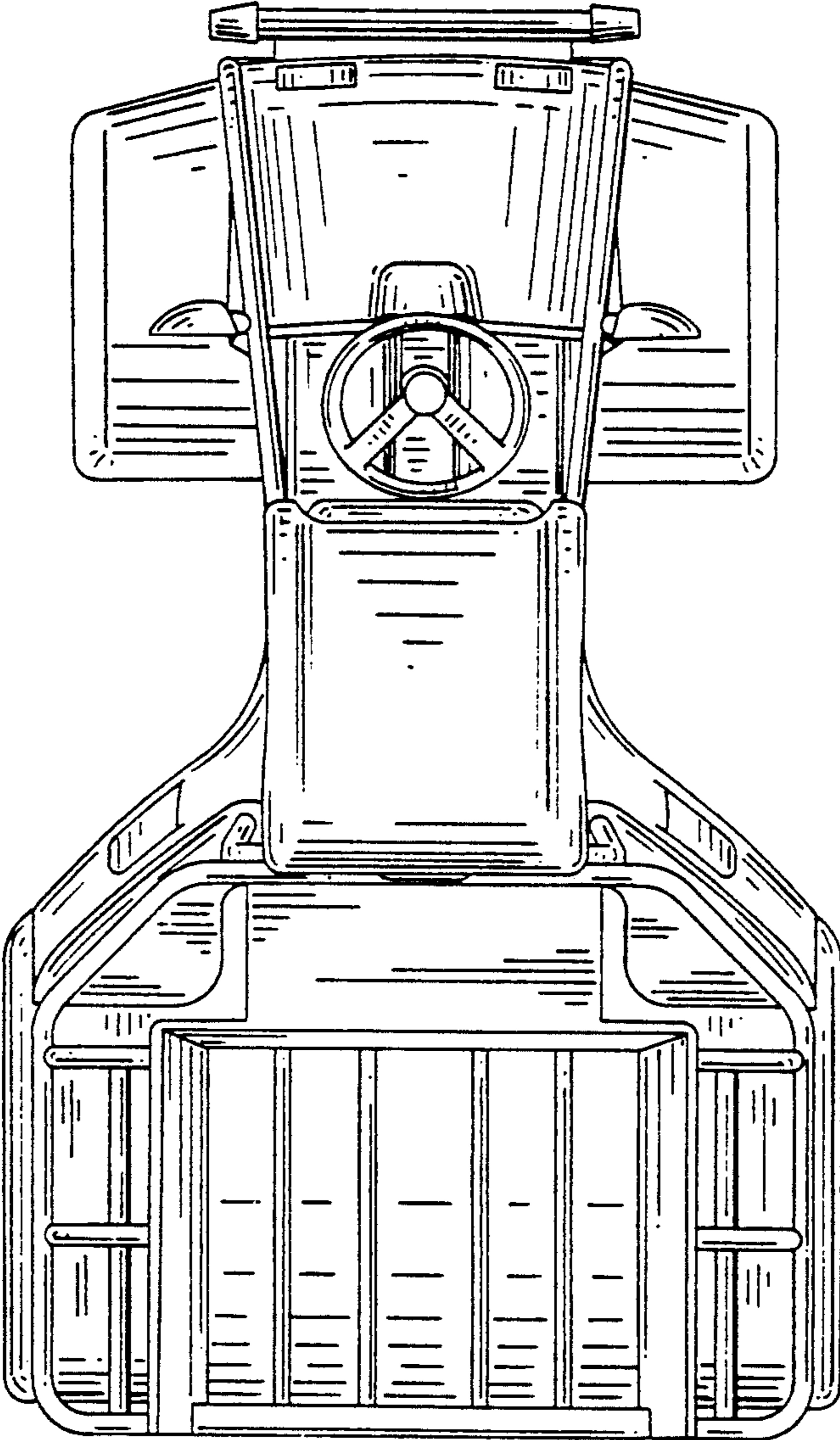

FIG.2

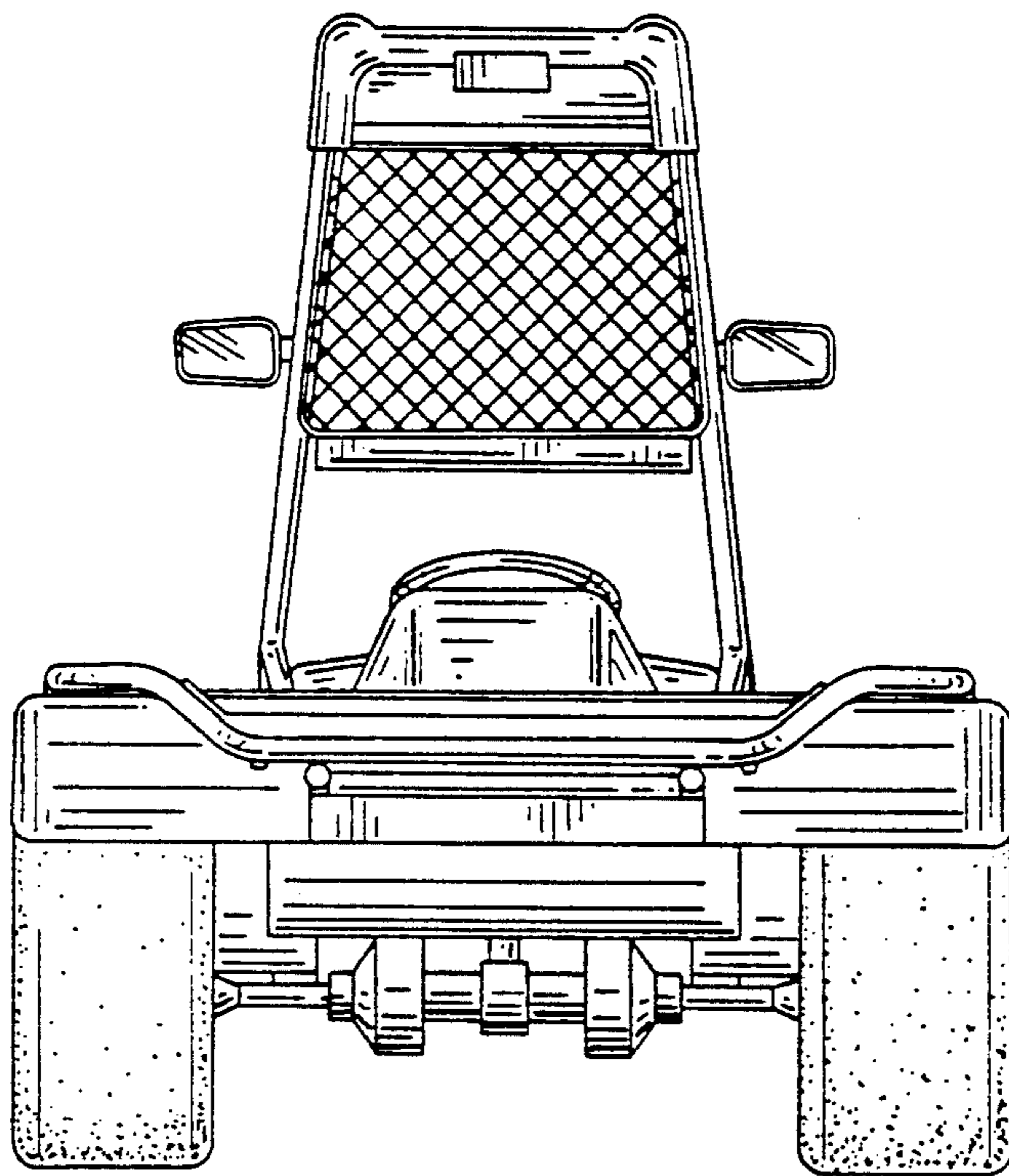

FIG.3

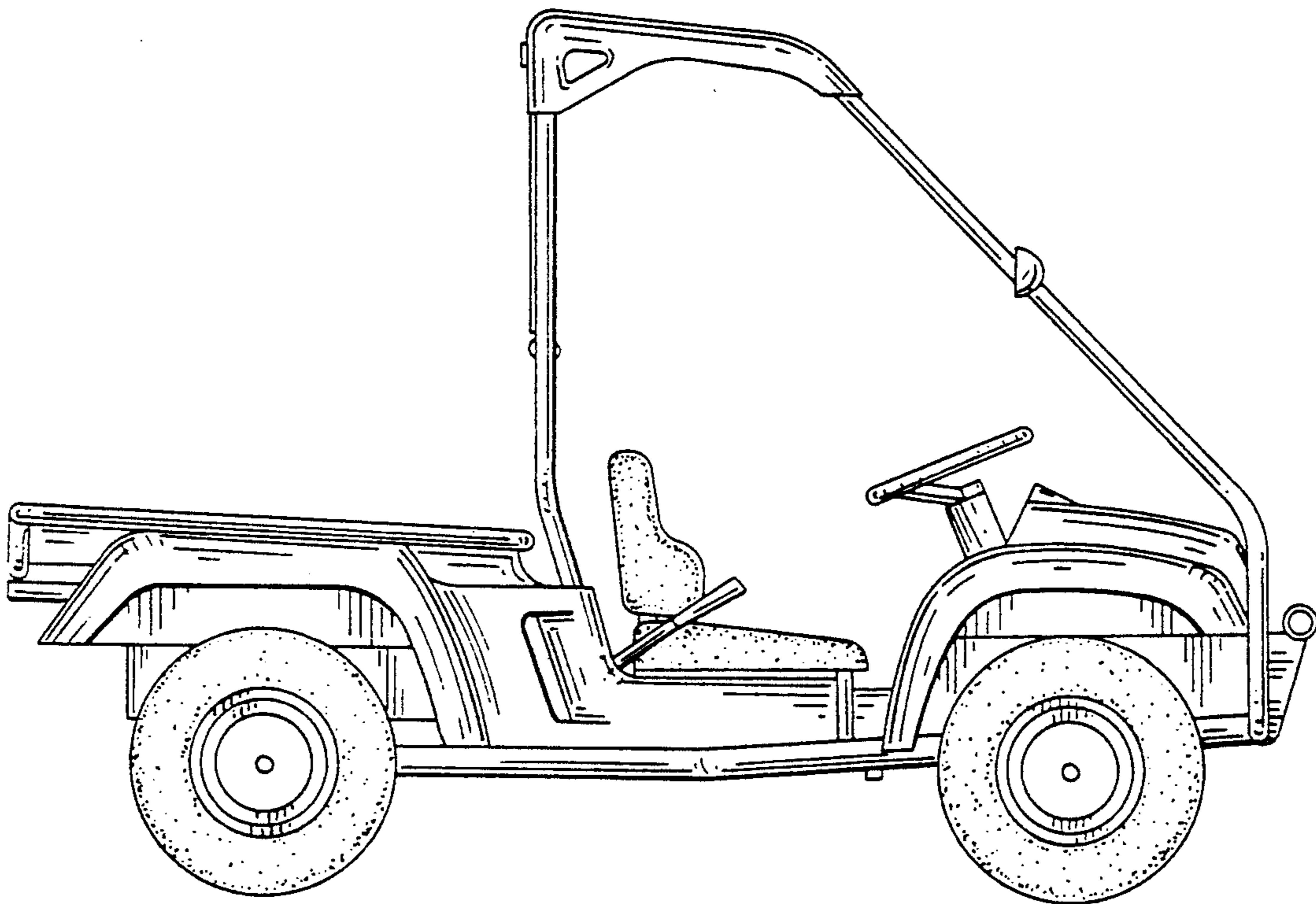

FIG.4

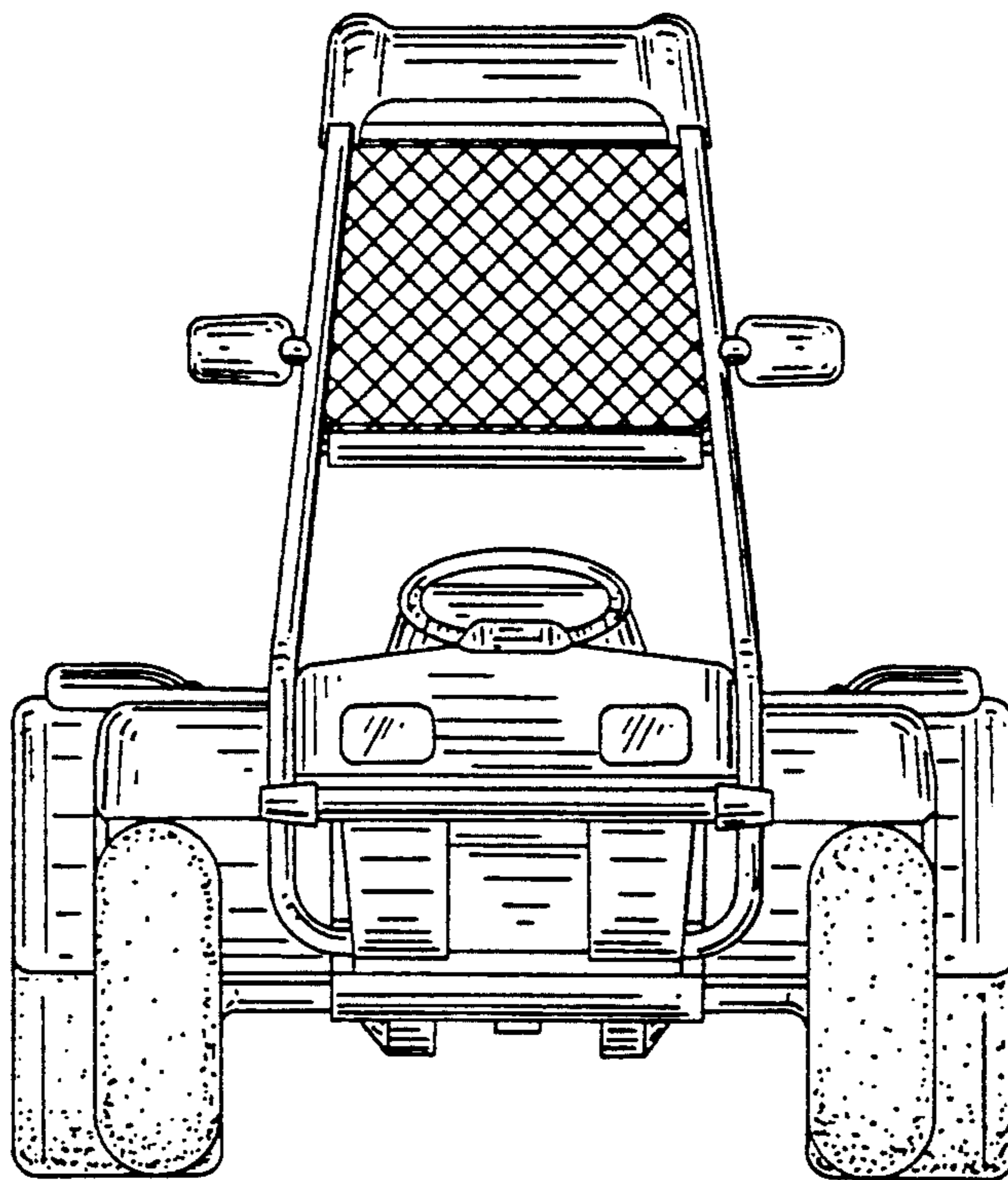

FIG.5

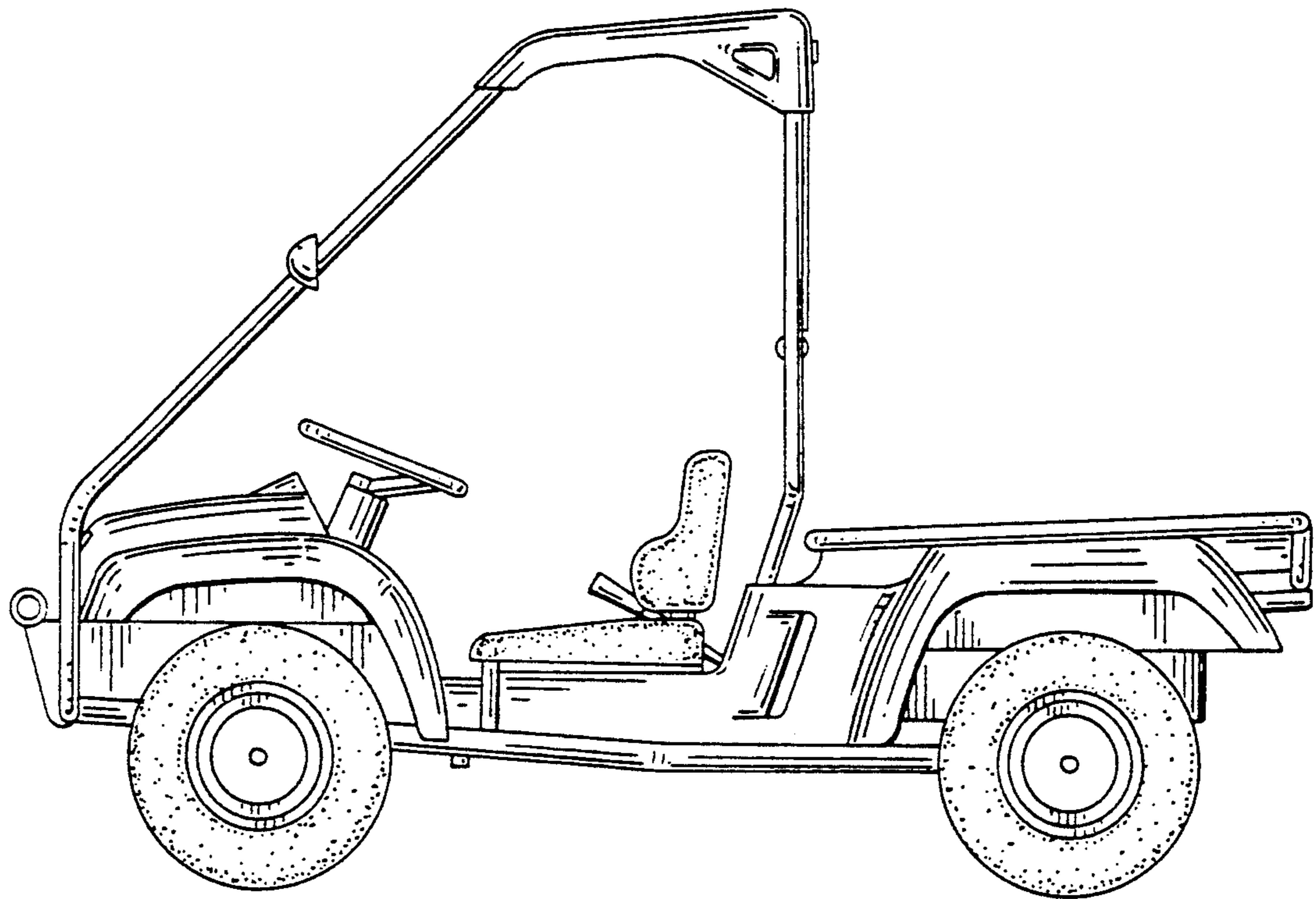

FIG.6

