



US00D342430S

# United States Patent [19]

Saito et al.

[11] Patent Number: **Des. 342,430**

[45] Date of Patent: **\*\* Dec. 21, 1993**

[54] **PORTABLE ELECTRIC IMPACT DRIVER**

D. 320,917 10/1991 Fushiya et al. .... D8/68  
D. 329,580 9/1992 Sasaki et al. .... D8/68

[75] Inventors: **Toshiaki Saito, Tokyo; Akio Takamura, Hiroshima, both of Japan**

[73] Assignee: **Ryobi Ltd., Hiroshima, Japan**

[\*\*] Term: **14 Years**

[21] Appl. No.: **877,030**

[22] Filed: **May 4, 1992**

[30] **Foreign Application Priority Data**

Nov. 26, 1991 [JP] Japan ..... 3-35759

[52] U.S. Cl. .... **D8/68**

[58] Field of Search ..... D8/68, 61; 173/170, 173/90, 91, 92, 93; 408/124, 125; 81/57.13

[56] **References Cited**

### U.S. PATENT DOCUMENTS

- D. 159,044 6/1950 Bushnell ..... D8/68
- D. 241,705 10/1976 Kotone ..... D8/68
- D. 295,714 5/1988 Sasaki et al. .... D8/68
- D. 315,855 4/1991 Fushiya et al. .... D8/68

### OTHER PUBLICATIONS

Kabushiki Kaisha Hitachi Seisakusho (Hitachi, Ltd.)  
Catalog Cordless Impact Driver, published Apr. 1991.

*Primary Examiner*—Alan P. Douglas  
*Assistant Examiner*—J. H. Musgrove  
*Attorney, Agent, or Firm*—Sughrue, Mion, Zinn,  
Macpeak & Seas

### [57] CLAIM

The ornamental design for a portable electric impact driver, as shown.

### DESCRIPTION

FIG. 1 is a front and right side perspective view of a portable electric impact driver showing our new design; FIG. 2 is a left side elevational view thereof; FIG. 3 is a right side elevational view thereof; FIG. 4 is a top plan view thereof; FIG. 5 is a bottom plan view thereof; FIG. 6 is a rear elevational view thereof; and, FIG. 7 is a front elevational view thereof.

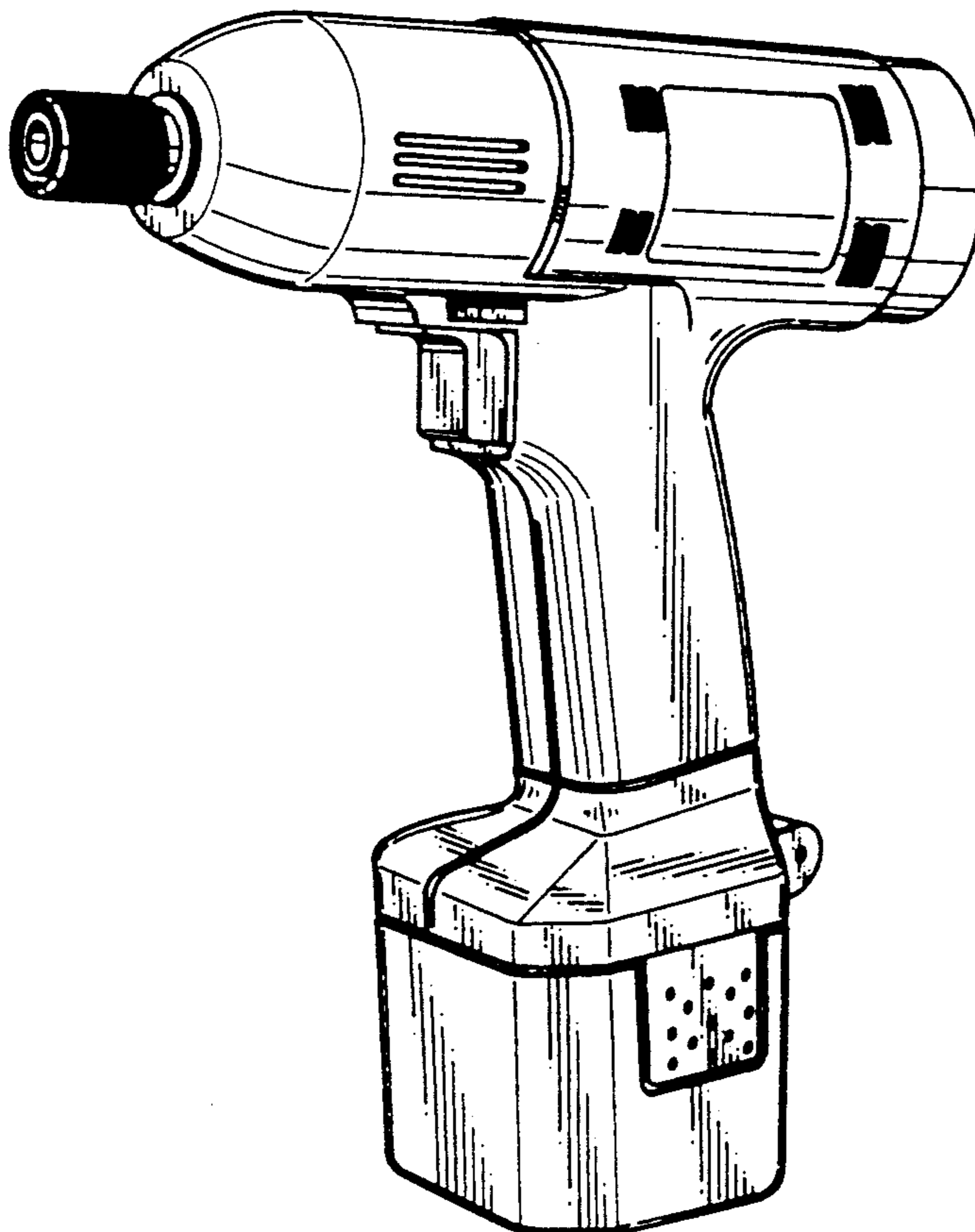

*Fig. 1*

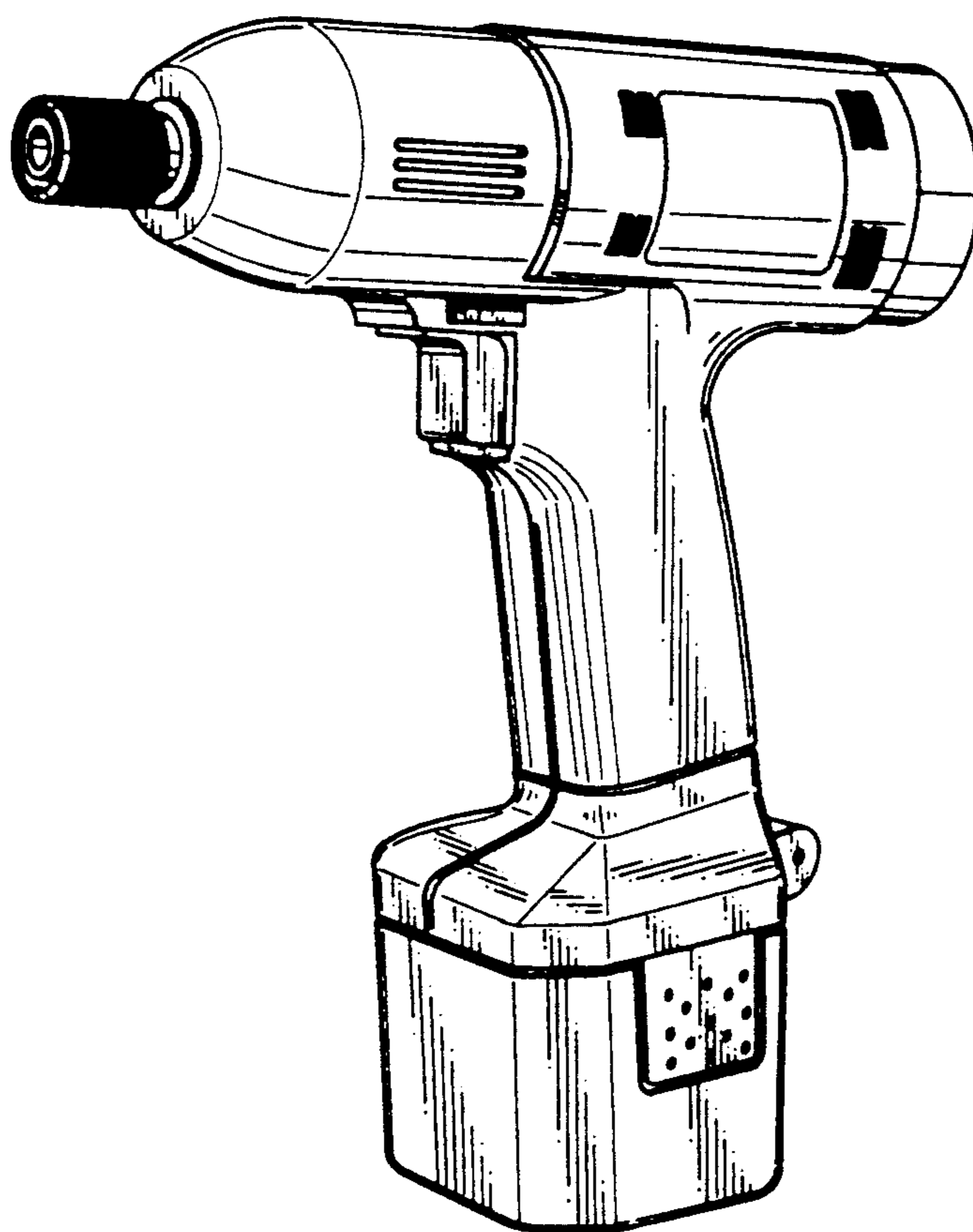

Fig. 3

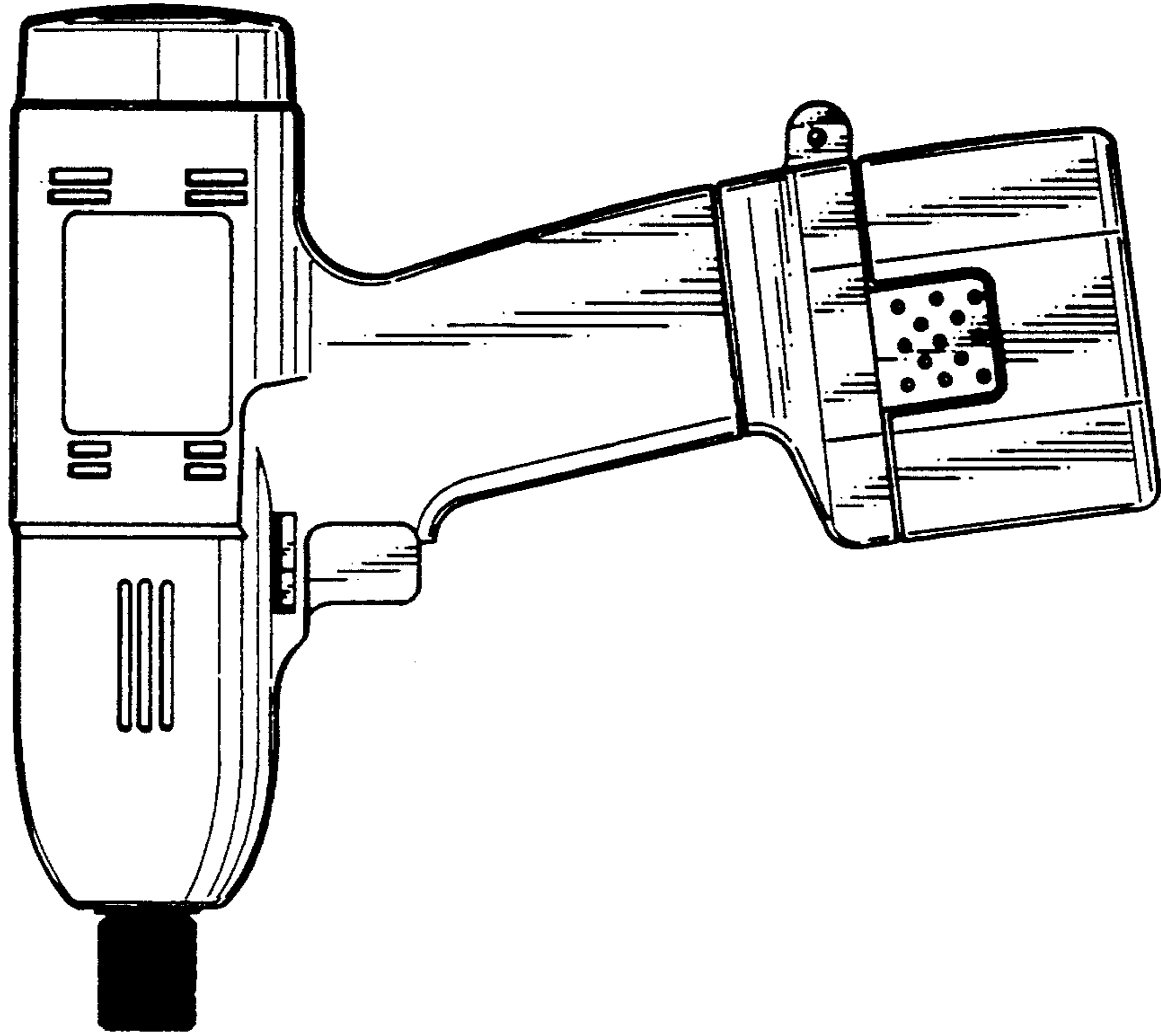
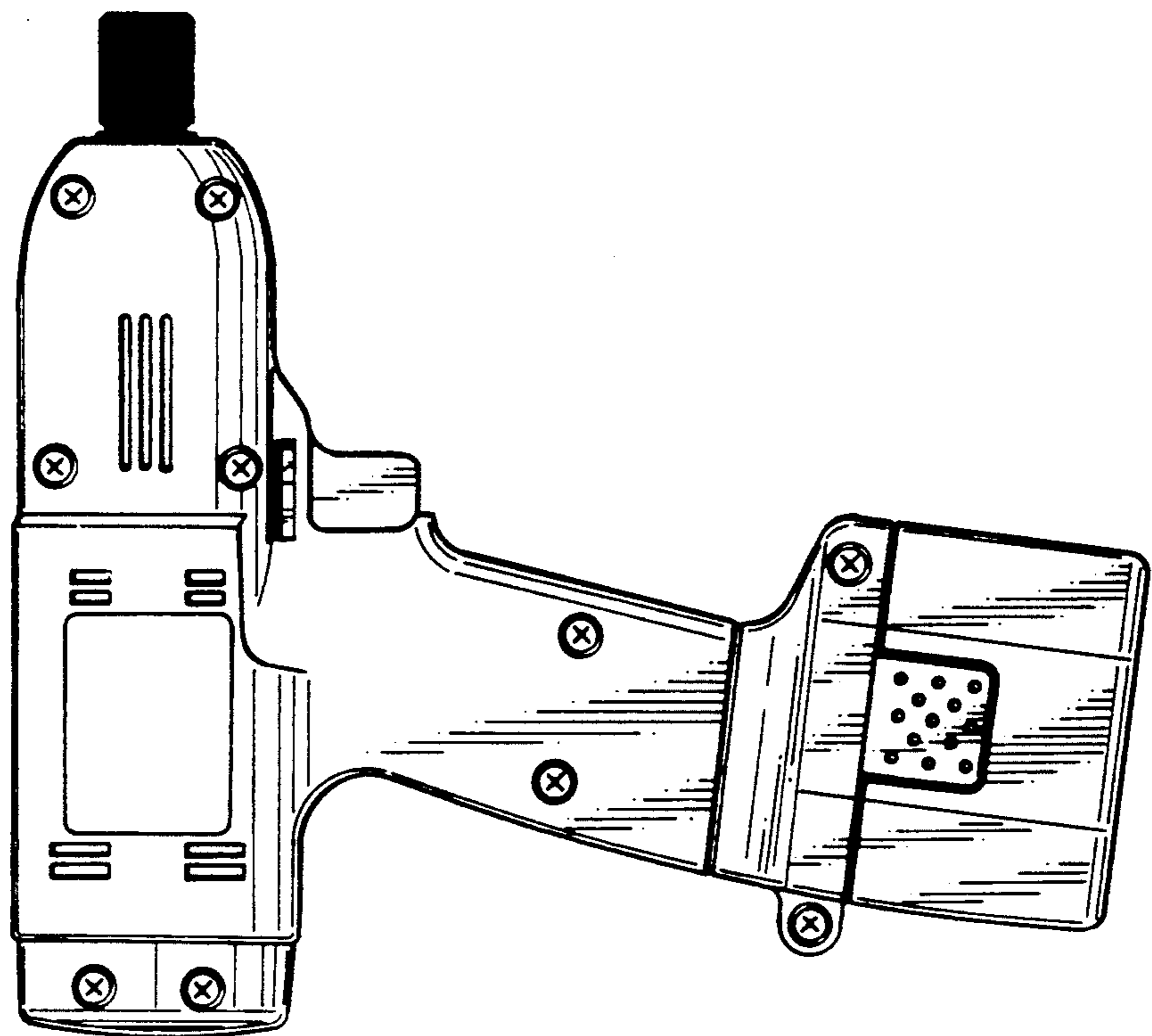
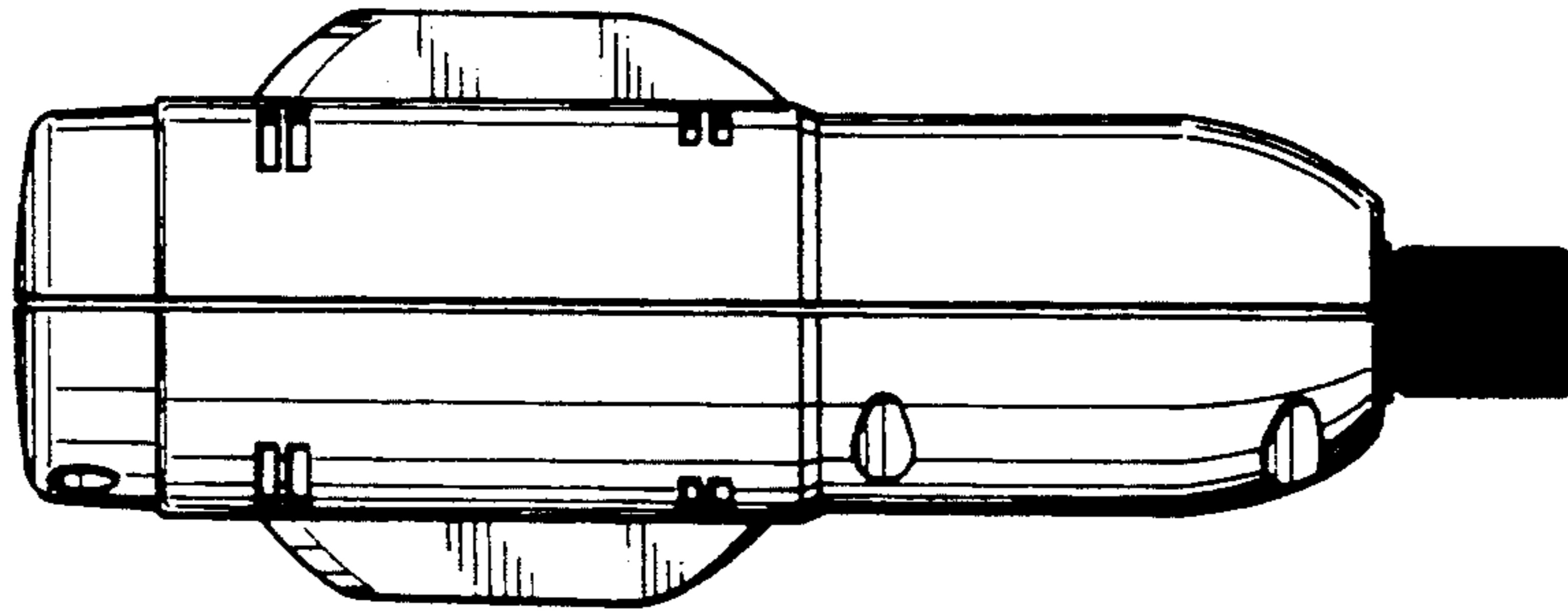

Fig. 2



*Fig. 4*



*Fig. 5*

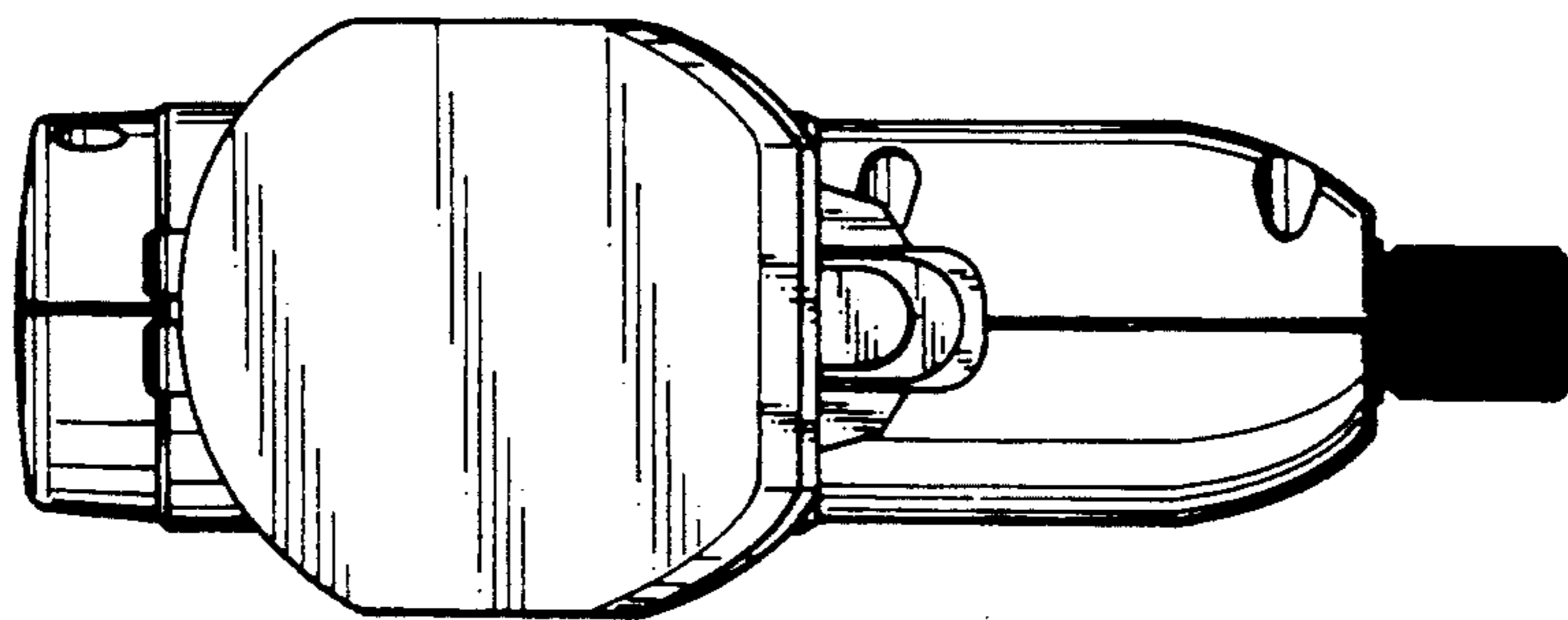

*Fig. 6*

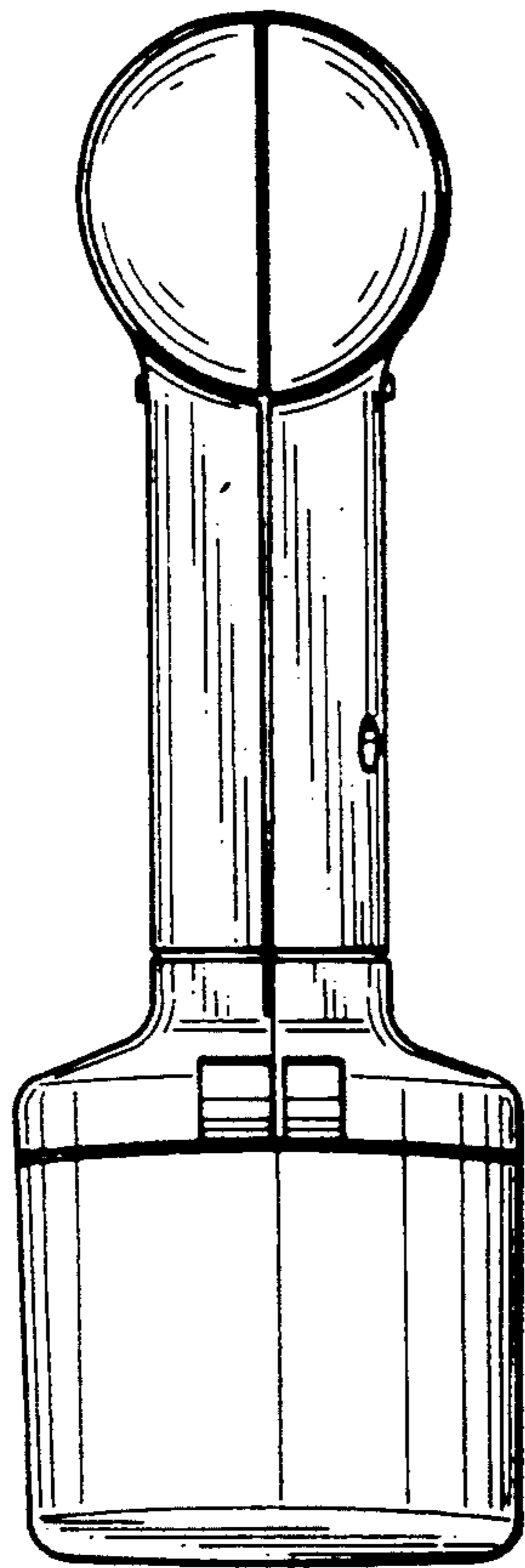

*Fig. 7*

