



US00D342138S

United States Patent [19]

Wollman et al.

[11] Patent Number: **Des. 342,138**

[45] Date of Patent: **** Dec. 7, 1993**

[54] **HAND-HELD MASSAGER**

[75] Inventors: **Howard Wollman; Matt J. Wollman,**
both of North Hollywood, Calif.

[73] Assignee: **HWE, Inc.,** North Hollywood, Calif.

[**] Term: **14 Years**

[21] Appl. No.: **845,463**

[22] Filed: **Mar. 5, 1992**

[52] U.S. Cl. **D24/214**

[58] Field of Search **D24/215, 214; 128/24 R,**
128/24.1, 24.2, 44-50, 56, 57, 65

[56] **References Cited**

U.S. PATENT DOCUMENTS

- D. 311,955 11/1990 Lie D24/214 X
- D. 315,408 3/1991 Duck D24/214 X
- D. 331,467 12/1992 Wollman D24/214

D. 338,070 8/1993 Lam D24/214
4,846,158 7/1989 Teranishi D24/214 X

Primary Examiner—Stella Reid
Attorney, Agent, or Firm—Michael A. Painter

[57] **CLAIM**

The ornamental design for a hand-held massager, as shown.

DESCRIPTION

FIG. 1 is a perspective view of a hand-held massager our new design;
FIG. 2 is a front elevation view thereof;
FIG. 3 is a top plan view thereof;
FIG. 4 is a bottom view thereof;
FIG. 5 is a back elevation view thereof;
FIG. 6 is a left side view taken from FIG. 2 thereof; and,
FIG. 7 is a right side view taken from FIG. 2 thereof.

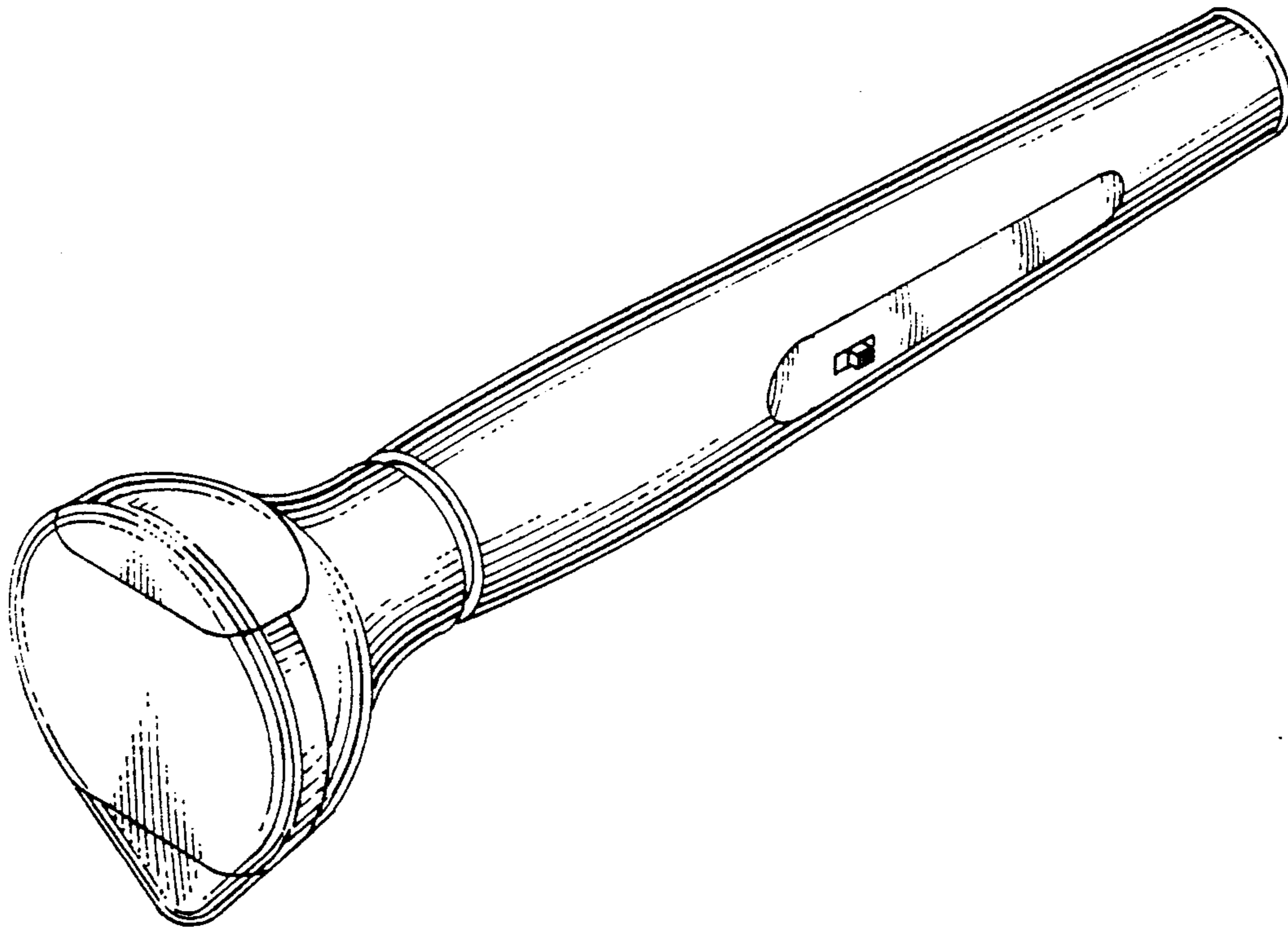

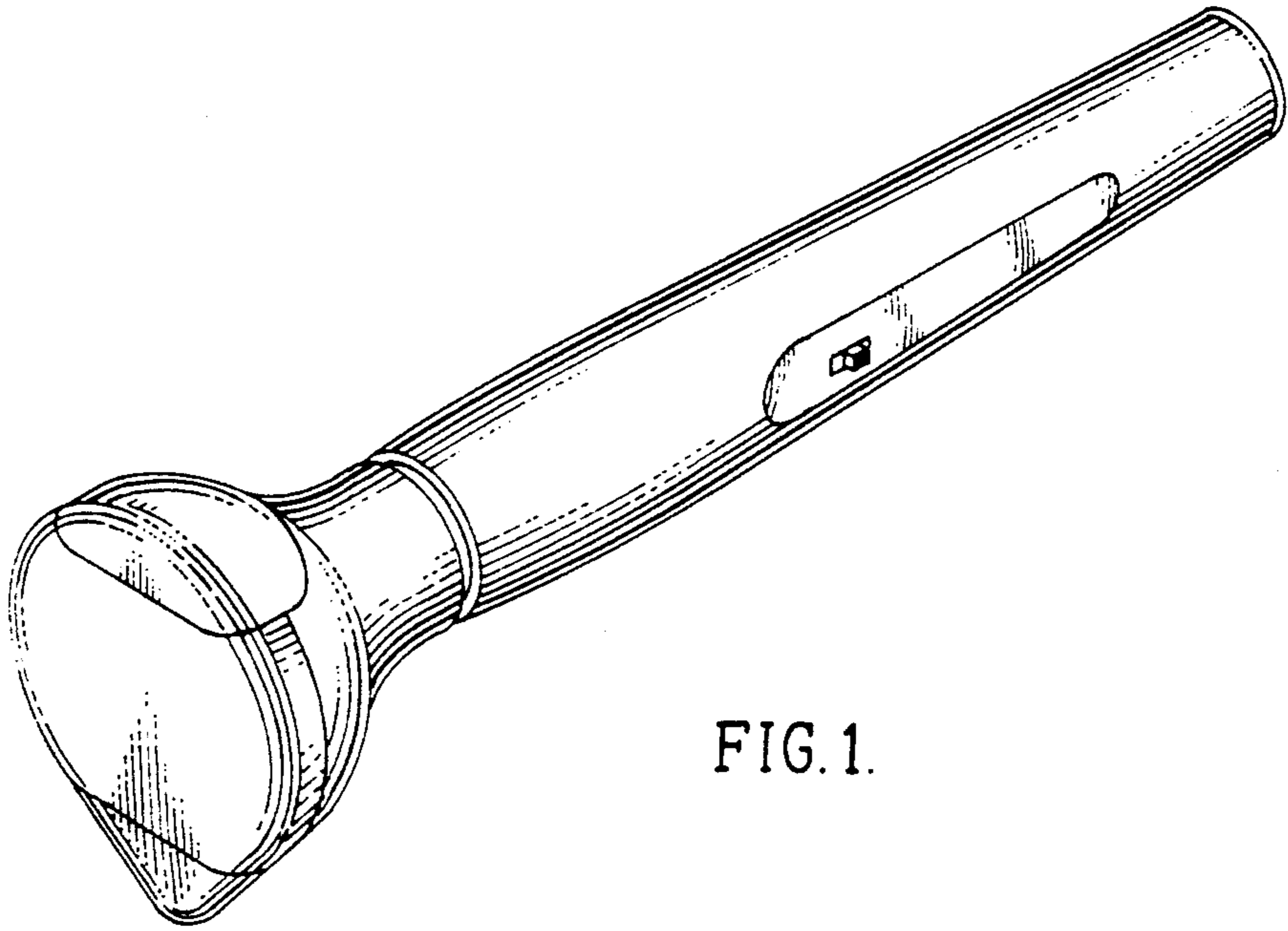

FIG. 1.

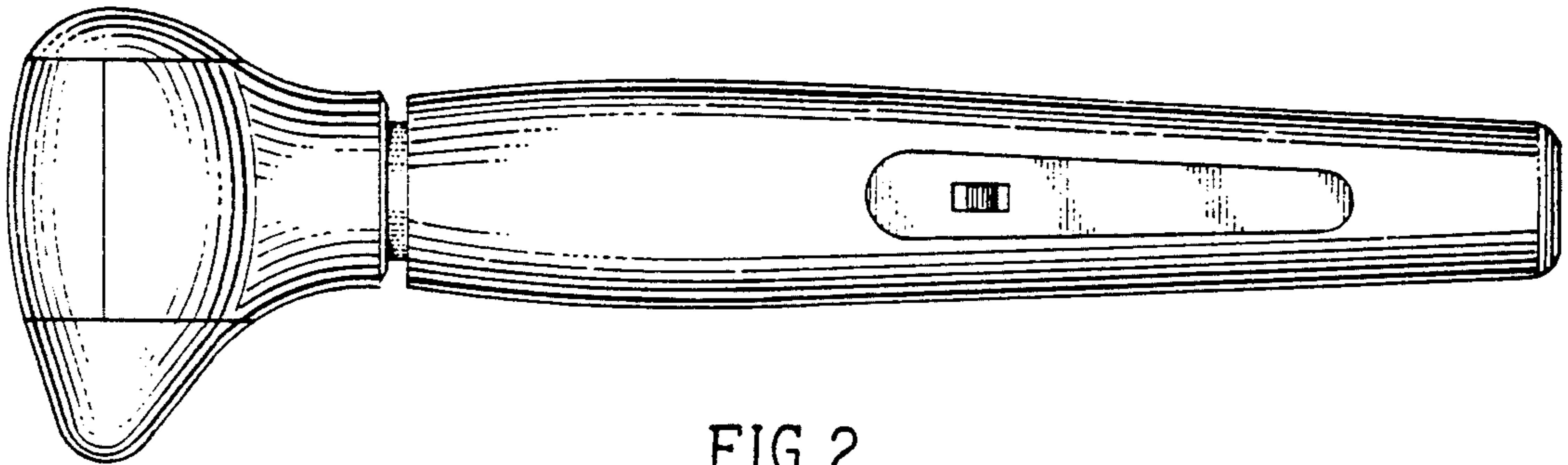

FIG. 2.

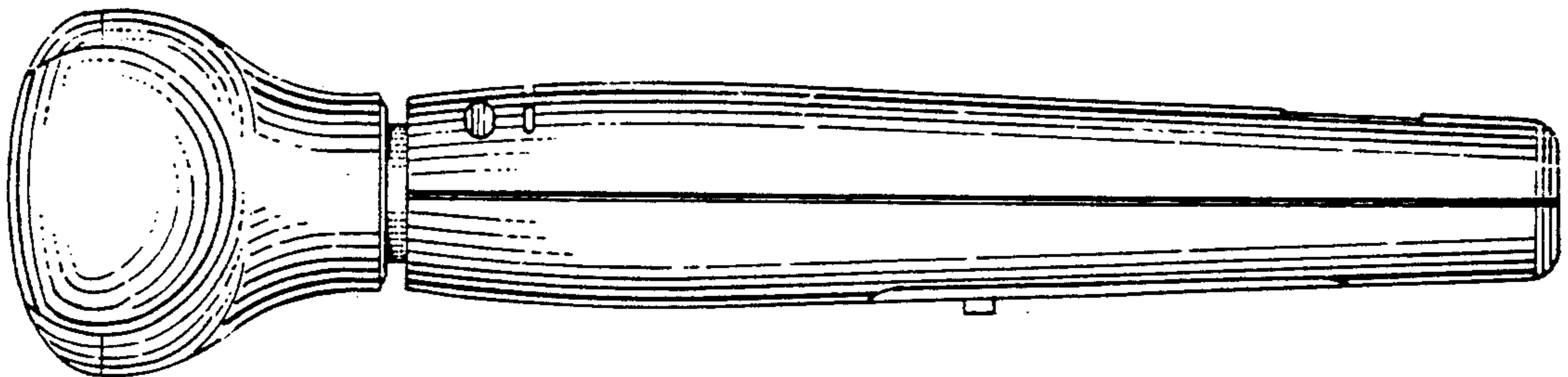

FIG. 3.

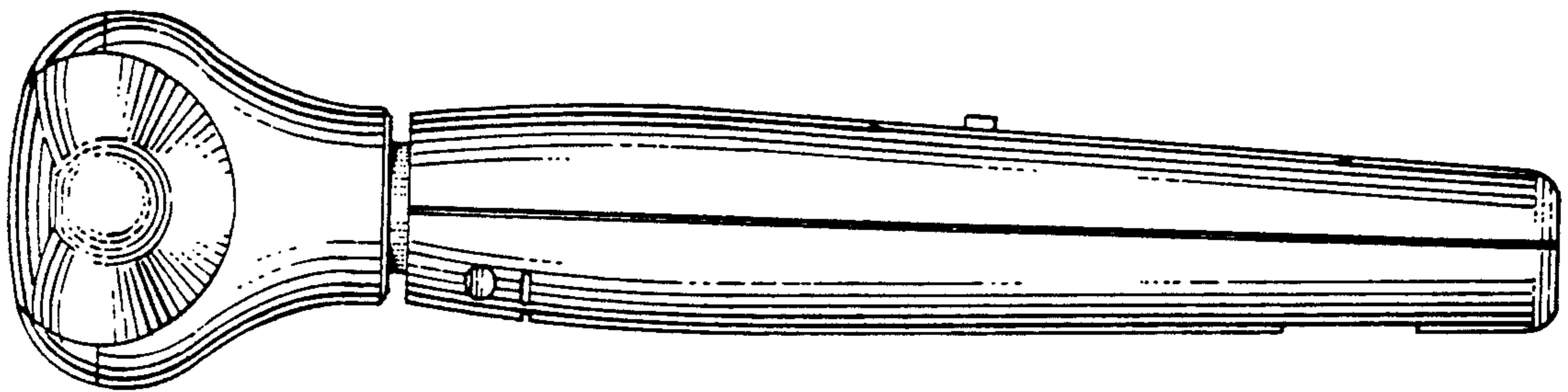

FIG. 4.

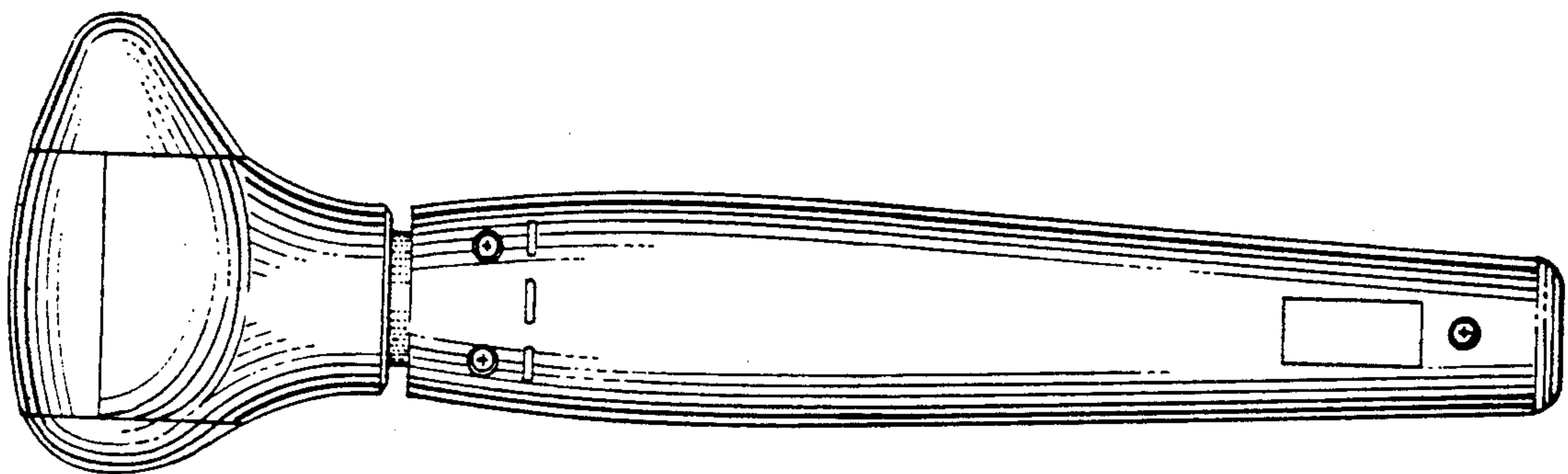

FIG. 5.

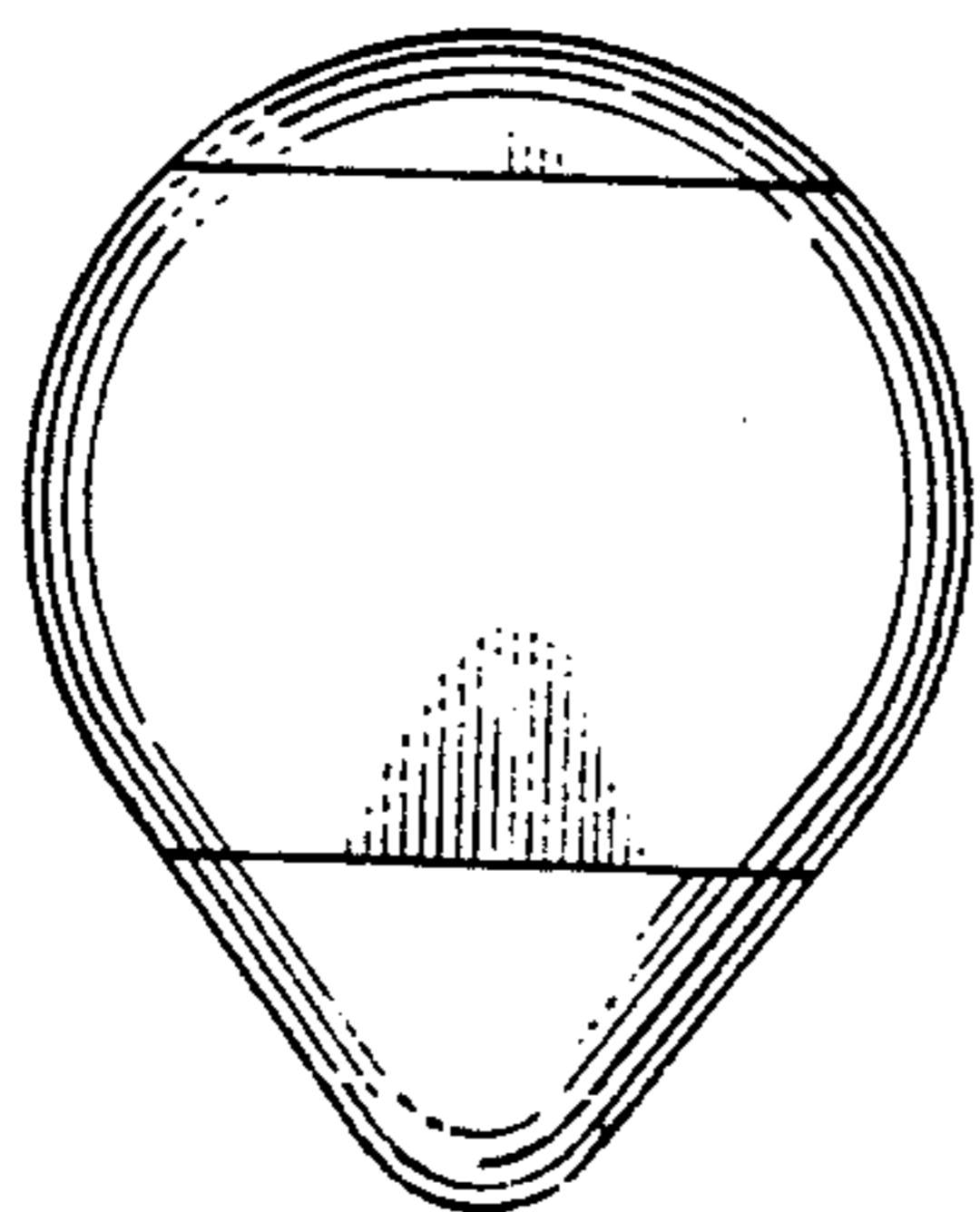

FIG. 6.

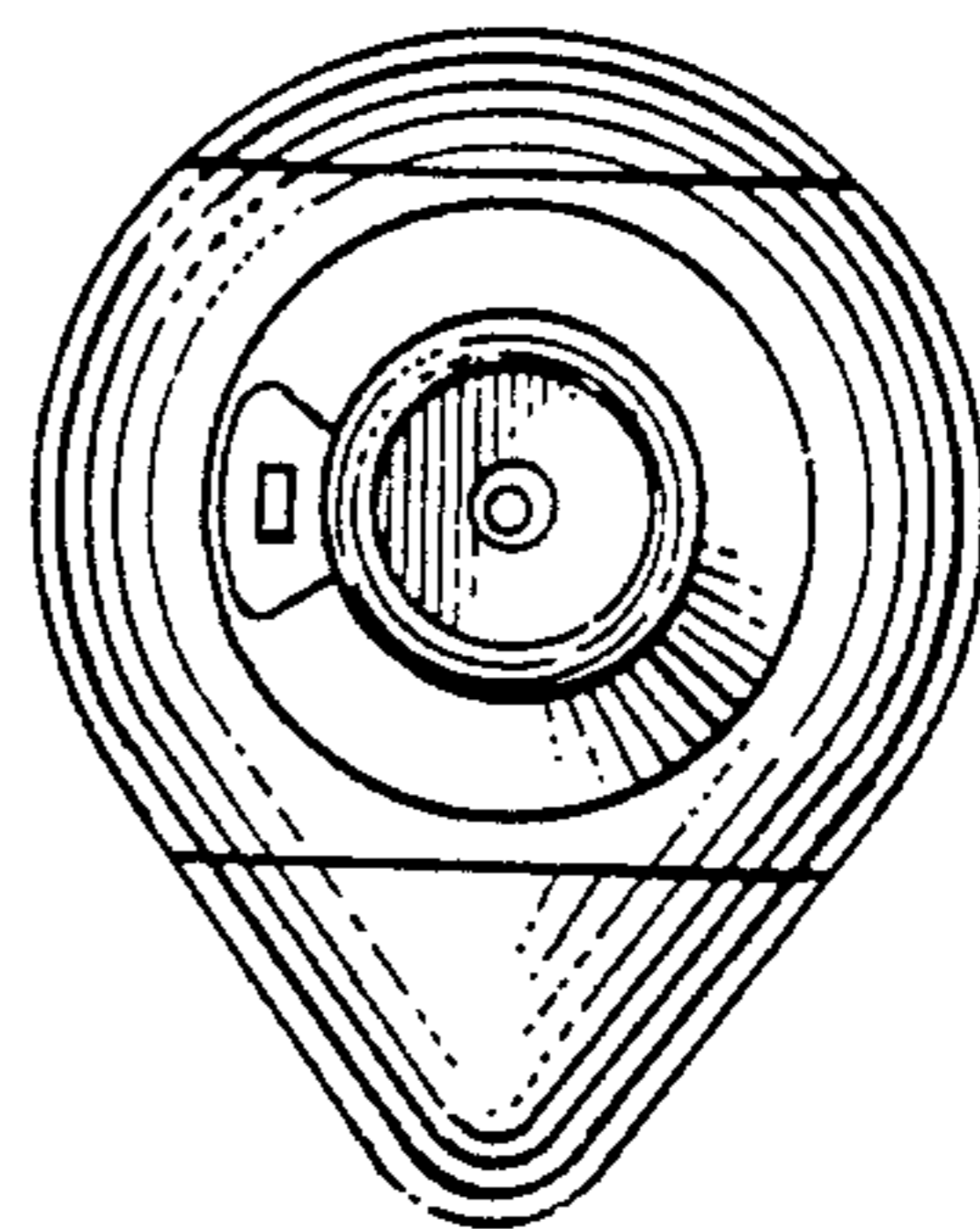

FIG. 7.