



US00D341861S

United States Patent [19] Chen

[11] Patent Number: **Des. 341,861**

[45] Date of Patent: **** Nov. 30, 1993**

[54] **PEDALLED SKATE**

[76] Inventor: **Teng-Huang Chen, No. 159,
Wu-Myau Road, Kaohsiung, Taiwan**

[**] Term: **14 Years**

[21] Appl. No.: **726,557**

[22] Filed: **Jul. 8, 1991**

[52] U.S. Cl. **D21/226**

[58] Field of Search **D21/194, 224, 226;
482/80; 280/11.115, 11.27, 11.19, 11.23, 11.24**

4,181,319 1/1980 Hirbod 280/11.115
 4,371,160 2/1983 Shooltz 482/80
 4,501,421 2/1985 Kane et al. 482/80
 4,515,382 5/1985 Boese 280/11.115
 4,786,069 11/1988 Tang 280/11.115

Primary Examiner—Bernard Ansher
Assistant Examiner—Philip Hyder

[57] **CLAIM**

The ornamental design for a pedalled skate, as shown and described.

DESCRIPTION

FIG. 1 is a top, front, and right side perspective view of an pedalled skate showing my new design;
 FIG. 2 is a front elevational view thereof;
 FIG. 3 is a rear elevational view thereof;
 FIG. 4 is a left side elevational view thereof;
 FIG. 5 is a right side elevational view thereof;
 FIG. 6 is a top plan view thereof; and,
 FIG. 7 is a bottom plan view thereof.

[56] **References Cited**
U.S. PATENT DOCUMENTS

D. 189,011	10/1960	Berne	482/80
D. 233,537	11/1974	Horner	D21/223
3,035,854	5/1962	Johnston	280/11.115
3,421,760	1/1969	Freeman, Jr.	482/80
3,672,670	6/1972	Burzenski	482/80
4,159,111	6/1979	Lowth	482/80

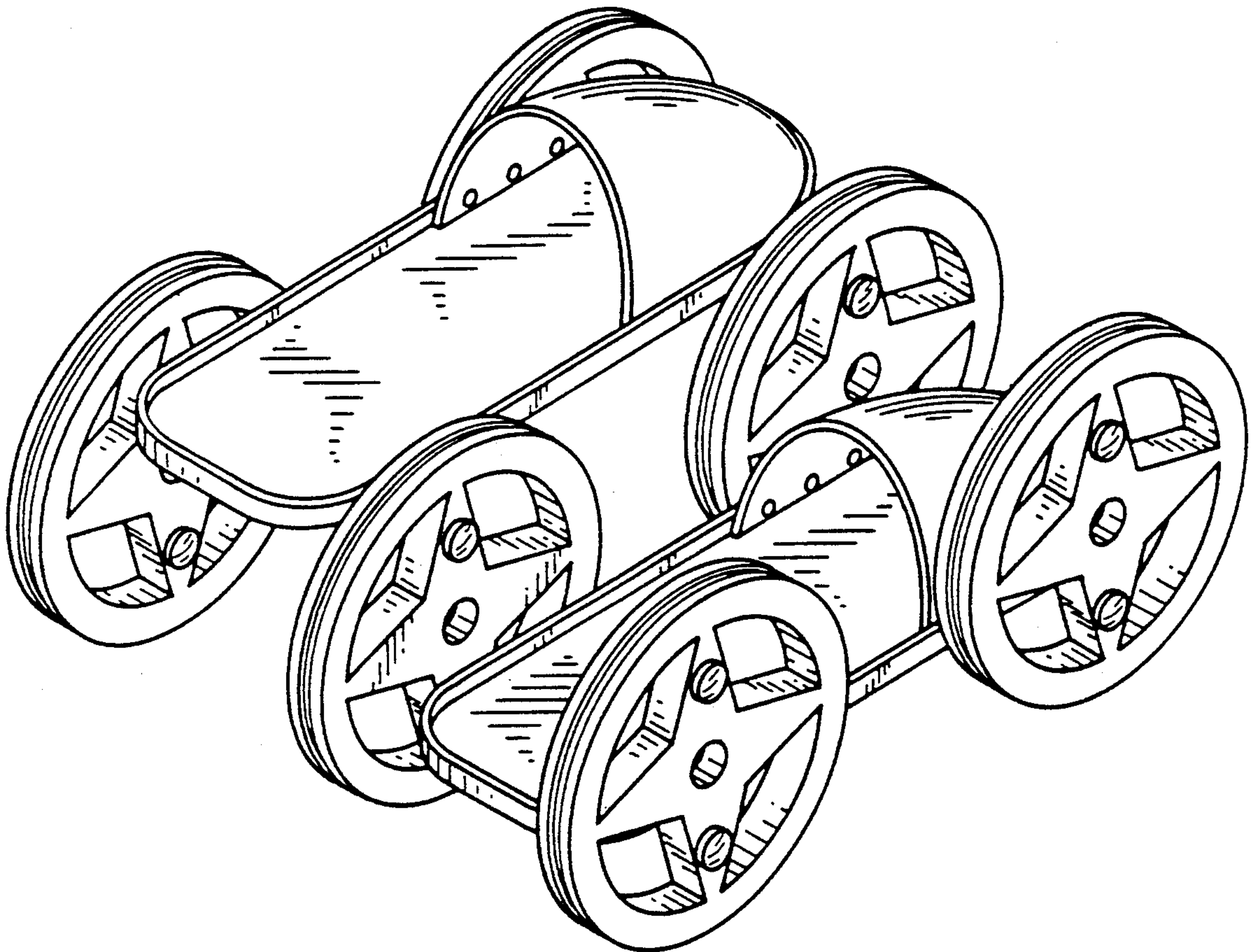

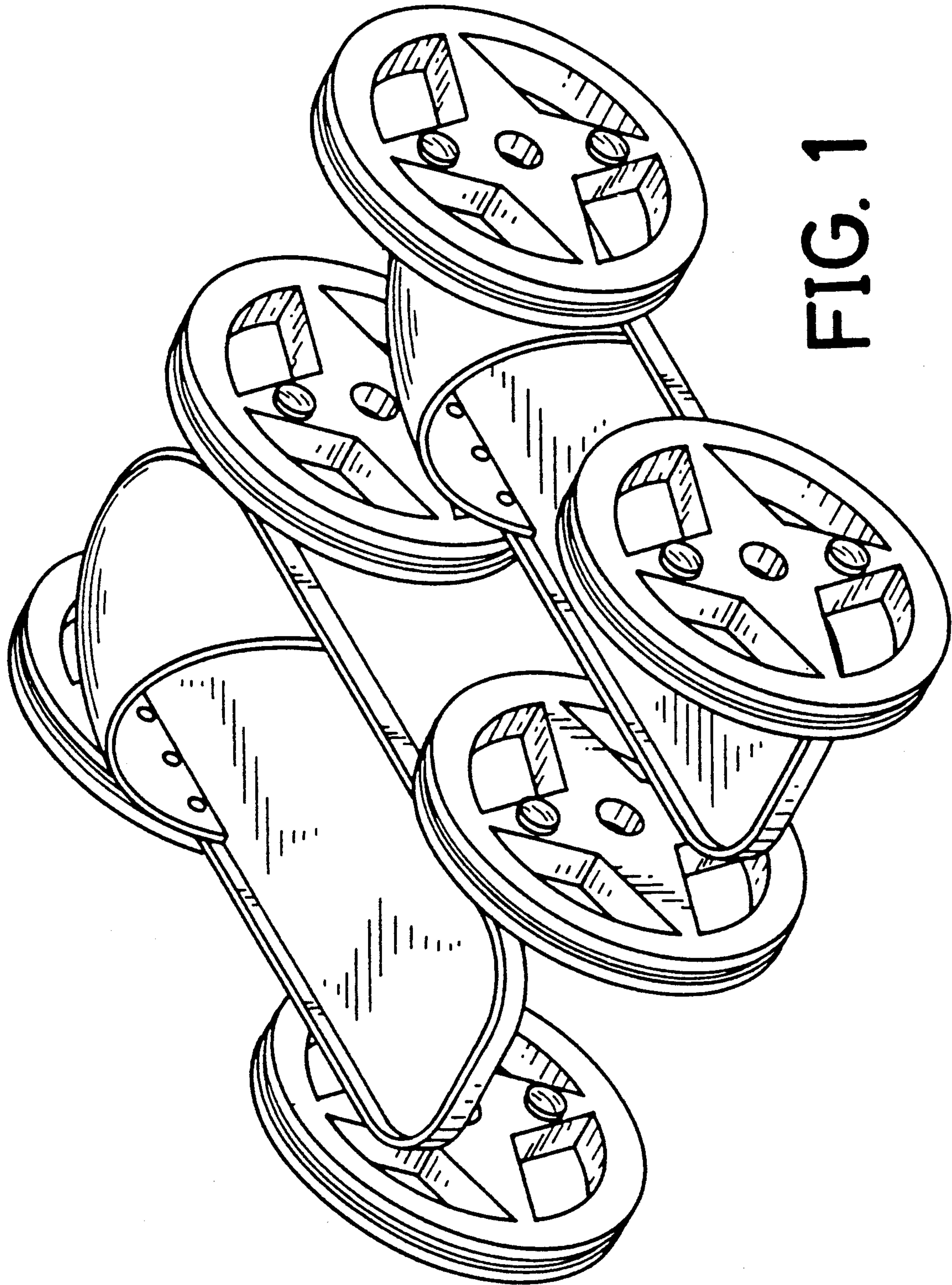

FIG. 1

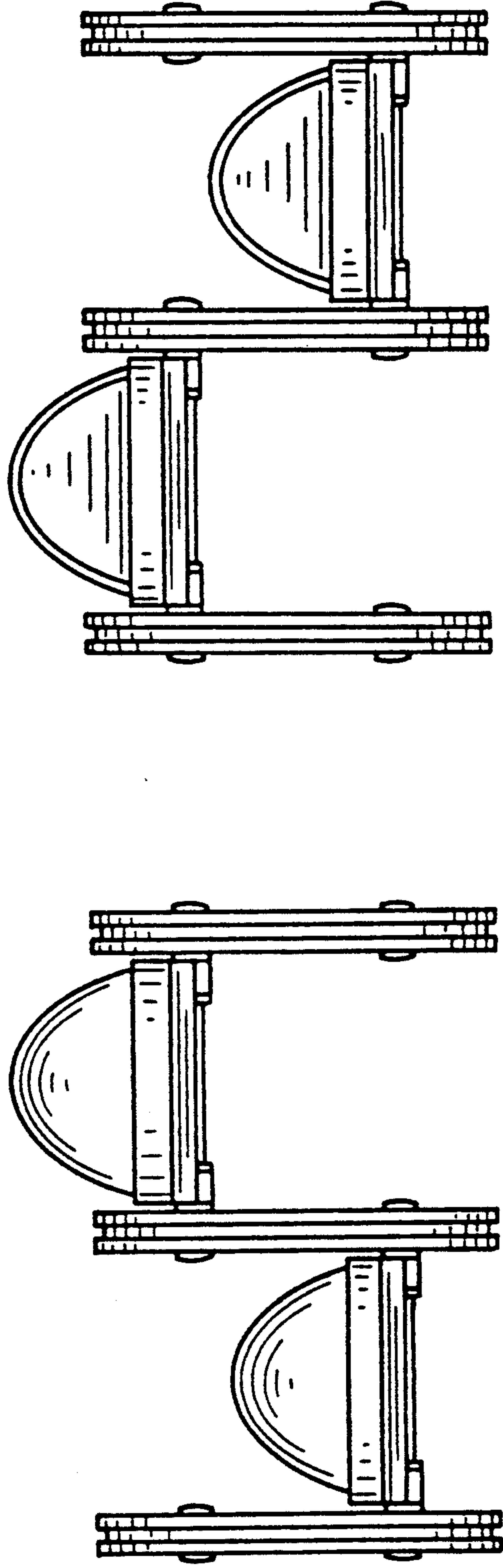

FIG. 3

FIG. 2

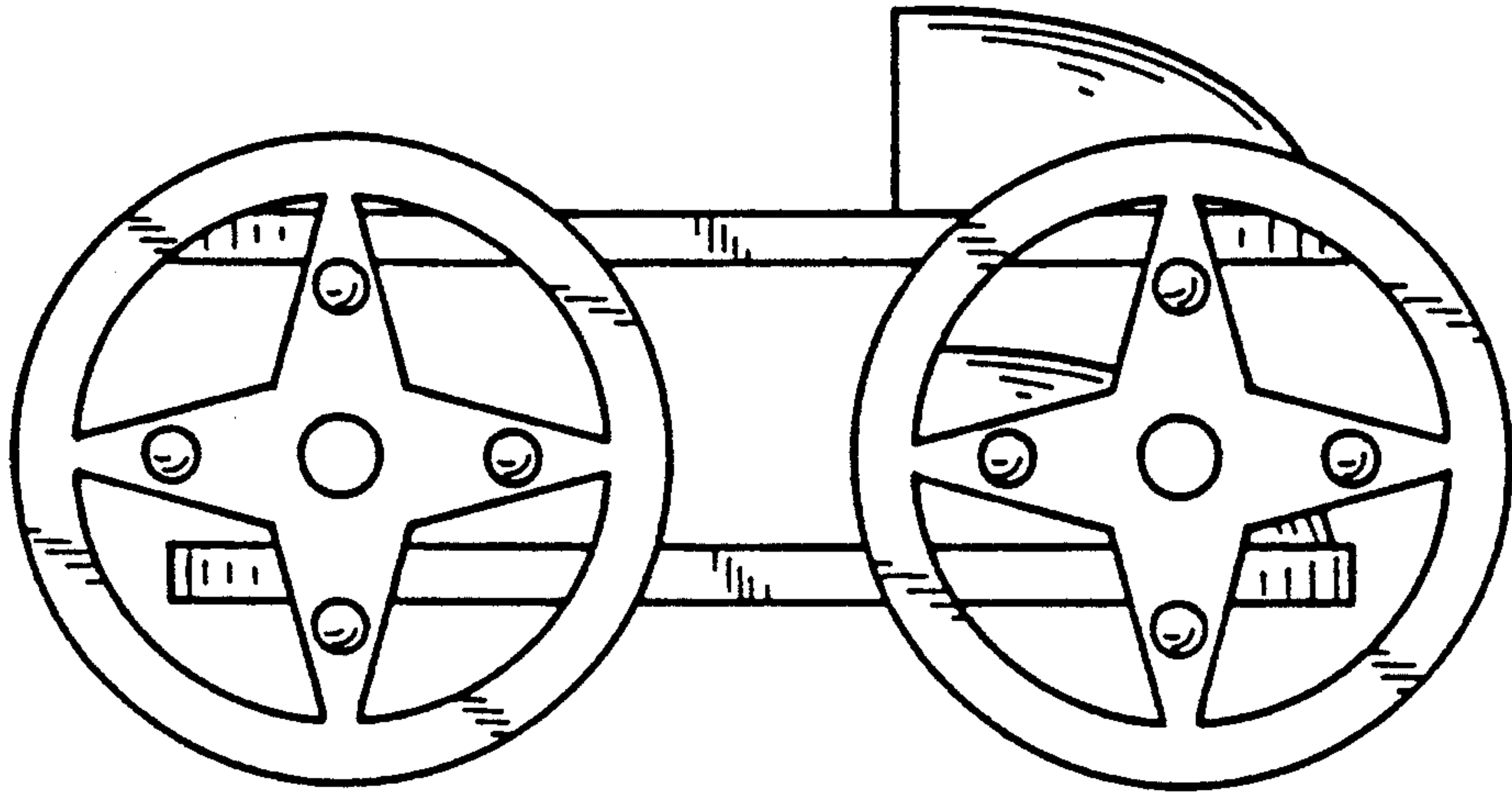

FIG. 4

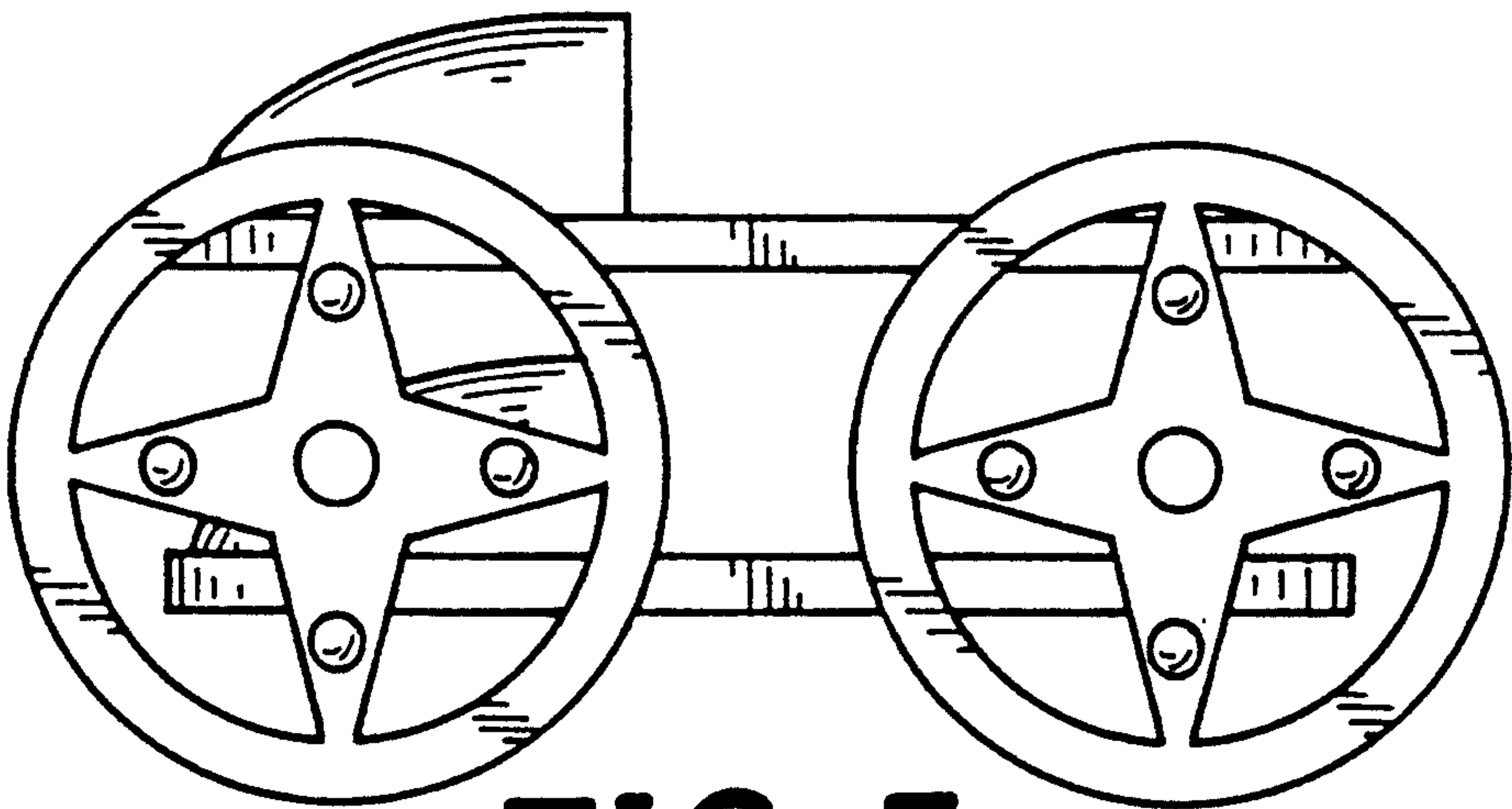

FIG. 5

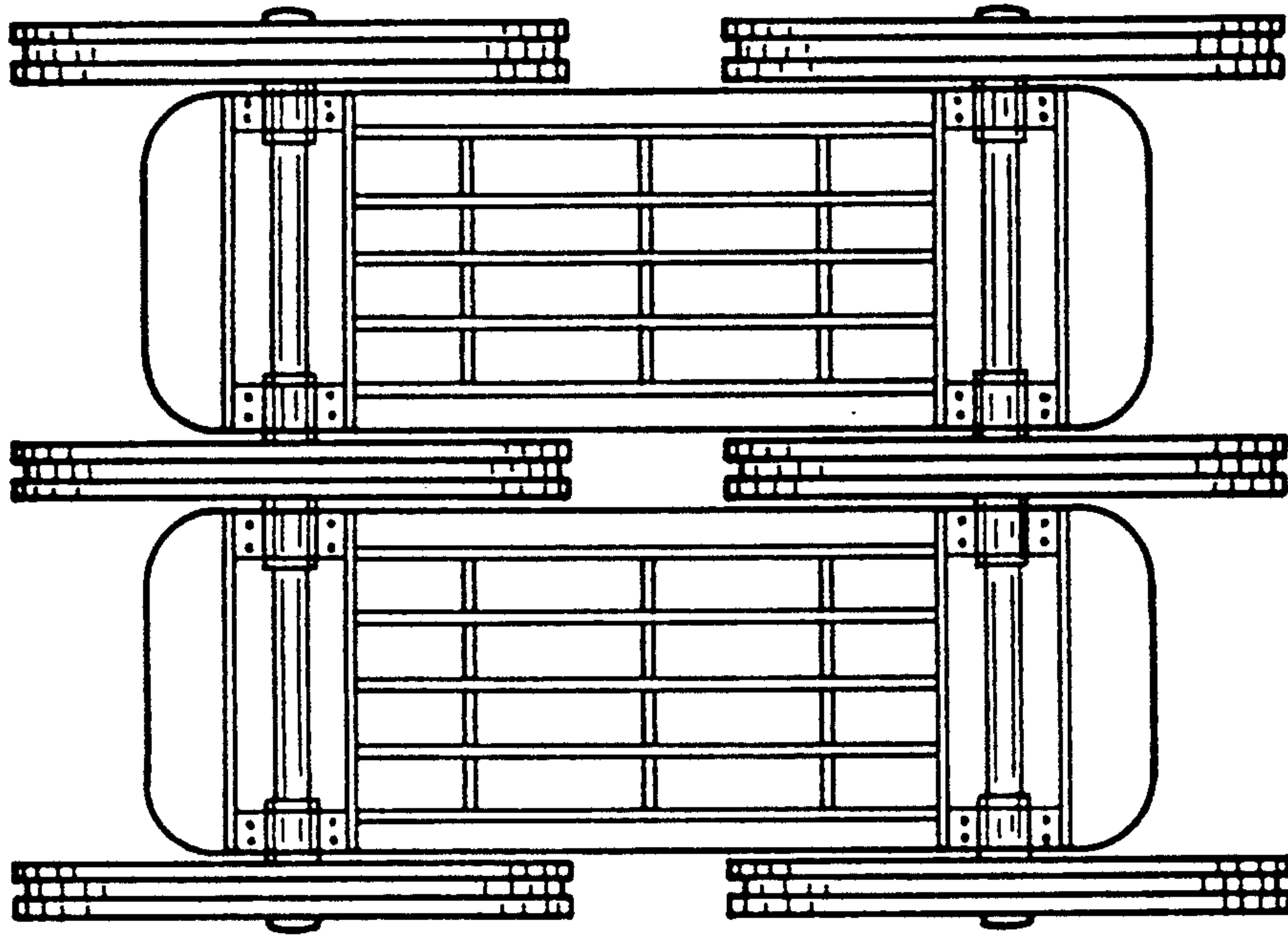

FIG. 7

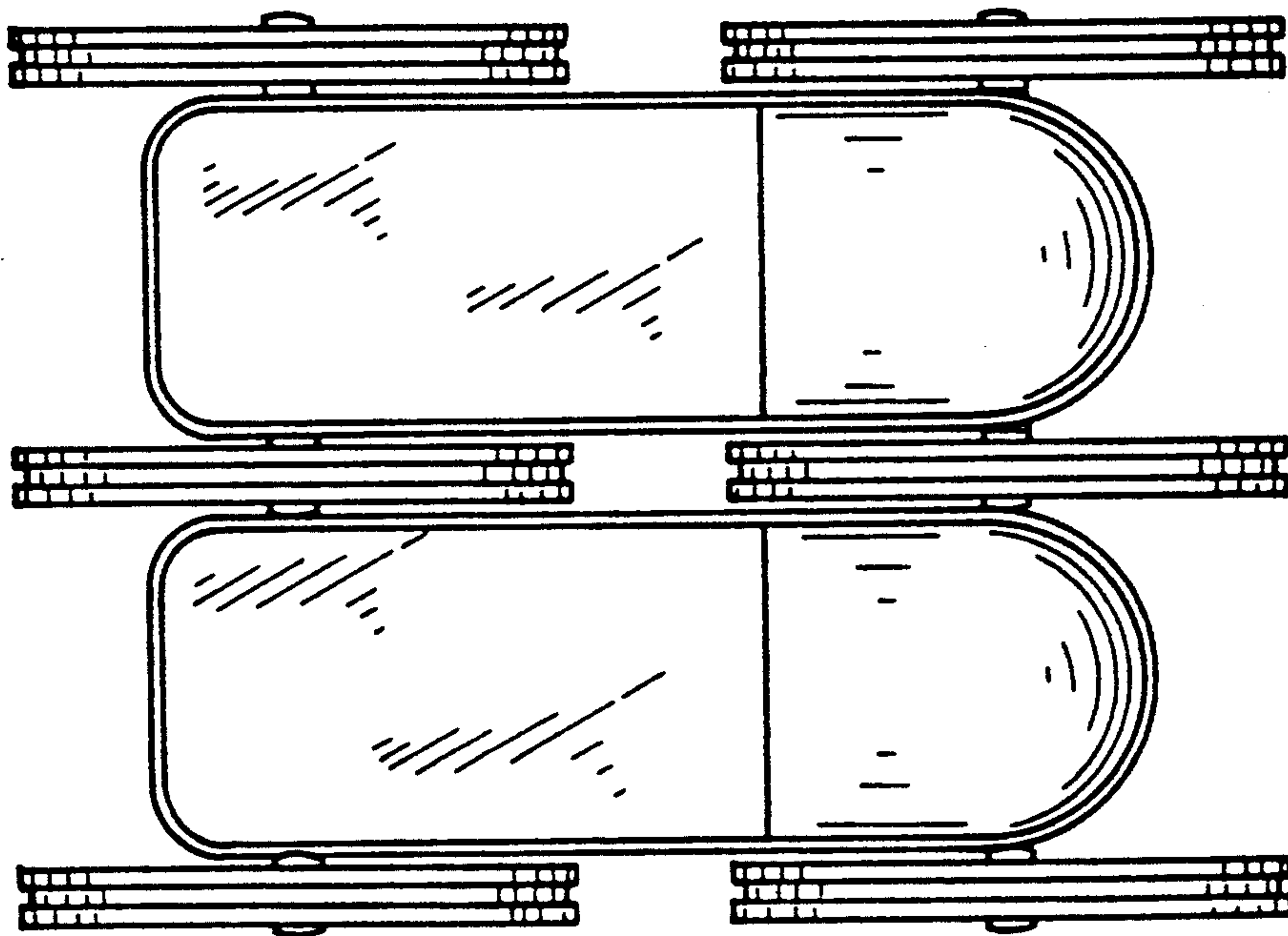

FIG. 6