



US00D341806S

United States Patent [19]

[11] Patent Number: **Des. 341,806**

Loehr

[45] Date of Patent: **** Nov. 30, 1993**

[54] **HANDLEBAR WITH INTEGRAL CRANK**

[76] Inventor: **Robert P. Loehr, 2 Sarian Dr., Neptune, N.J. 07753**

[**] Term: **14 Years**

[21] Appl. No.: **911,319**

[22] Filed: **Jul. 10, 1992**

[52] U.S. Cl. **D12/178**

[58] Field of Search **D12/178, 123, 111, 112, D12/113; 74/551.1, 551.3, 551.4, 551.8, 551.9; 482/62; 280/225, 260, 281.1, 288.1**

[56] **References Cited**

U.S. PATENT DOCUMENTS

D. 301,439	5/1989	Glasgow et al.	D12/113
3,193,305	7/1965	Hendricks	280/225
4,270,766	6/1981	Thomas	280/250
4,471,972	9/1984	Young	280/250
4,621,805	11/1986	Chen	74/551.3
4,705,269	11/1987	DoBoer et al.	482/62
4,749,182	7/1988	Duggan	482/62
4,842,269	7/1989	Huang	482/62
4,846,156	7/1989	Kopnický	482/62
4,863,157	9/1989	Mendel et al.	482/62

FOREIGN PATENT DOCUMENTS

0011789 10/1904 United Kingdom 280/250
1044078 9/1966 United Kingdom 280/250

Primary Examiner—Wallace R. Burke
Assistant Examiner—M. Brown
Attorney, Agent, or Firm—Patrick J. Pinto

[57] **CLAIM**

The ornamental design for a handlebar with integral crank, as shown and described.

DESCRIPTION

FIG. 1 is a front elevational view of a handlebar with integral crank, showing my new design; FIG. 2 is a bottom plan view thereof; FIG. 3 is a top plan view thereof; FIG. 4 is an inverted front elevational view thereof, showing the rear side and the handlebars rotated 180 degrees, the broken lines are for illustrative purposes only and form no part of the claimed design; FIG. 5 is a left side elevational view thereof taken along line 5—5 in FIG. 3; and, FIG. 6 is a right side elevational view thereof taken along line 6—6 in FIG. 3.

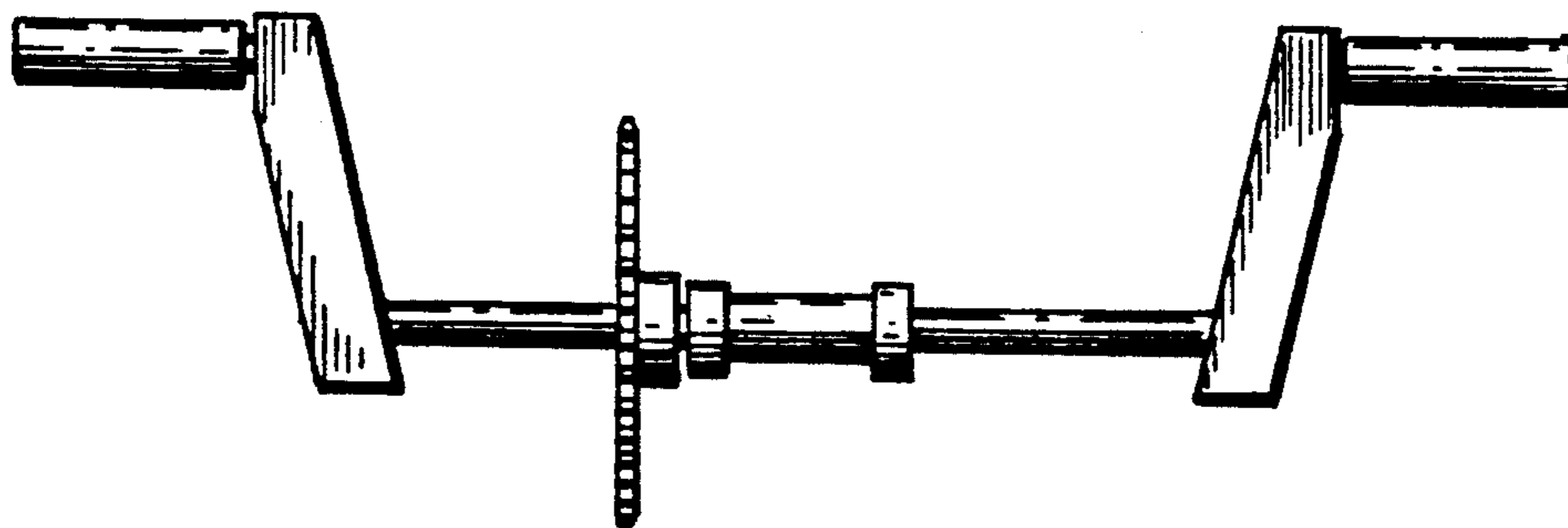

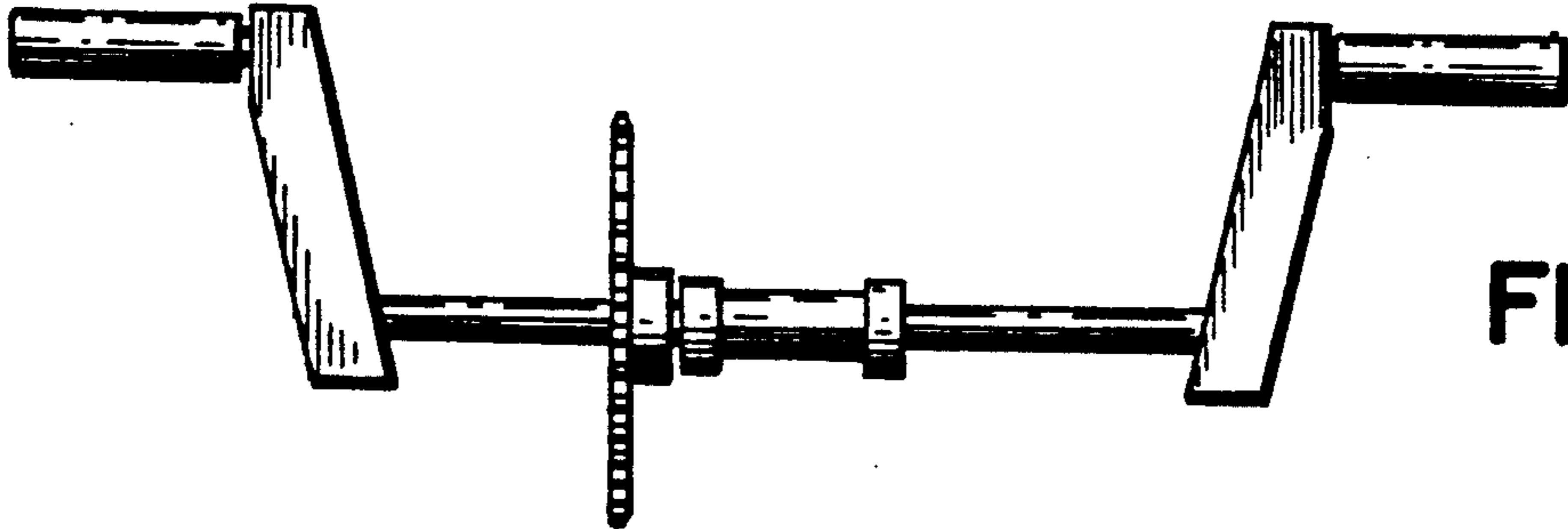

FIG. 1

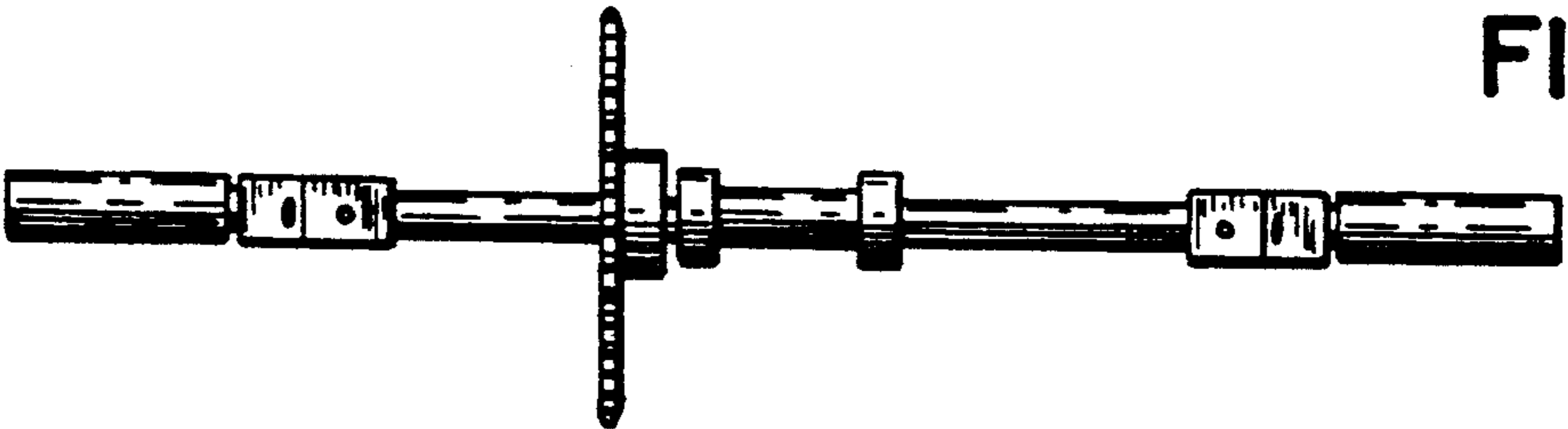

FIG. 2

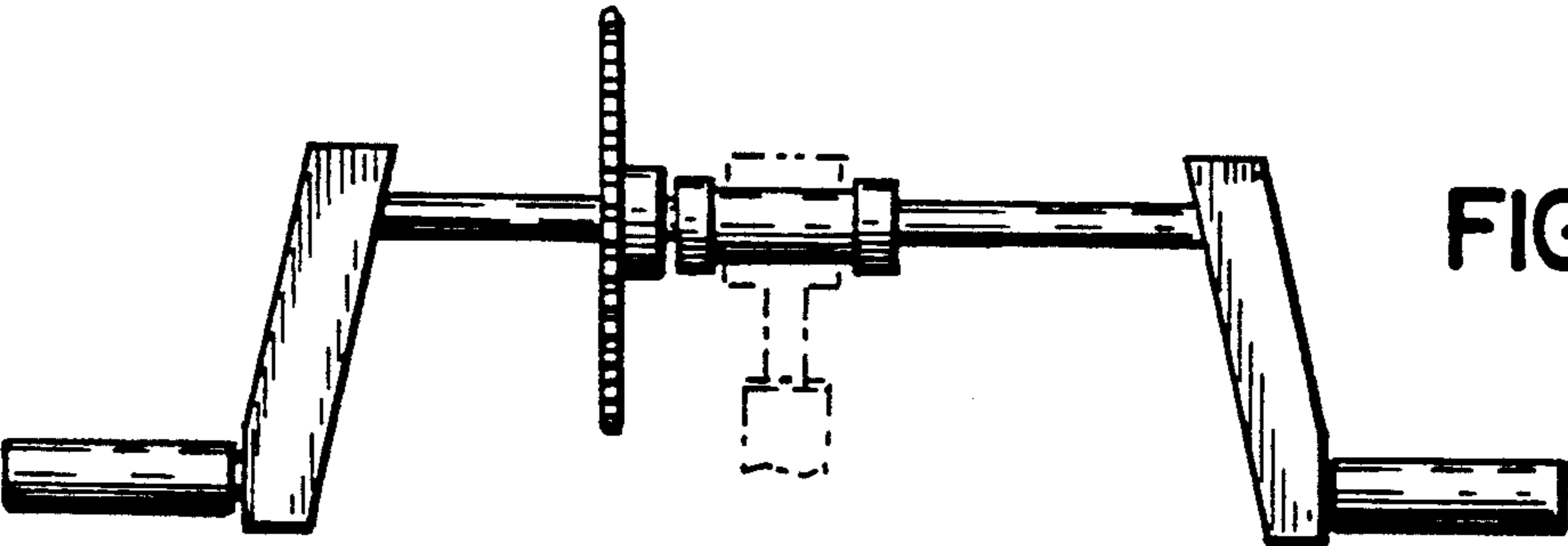

FIG. 4

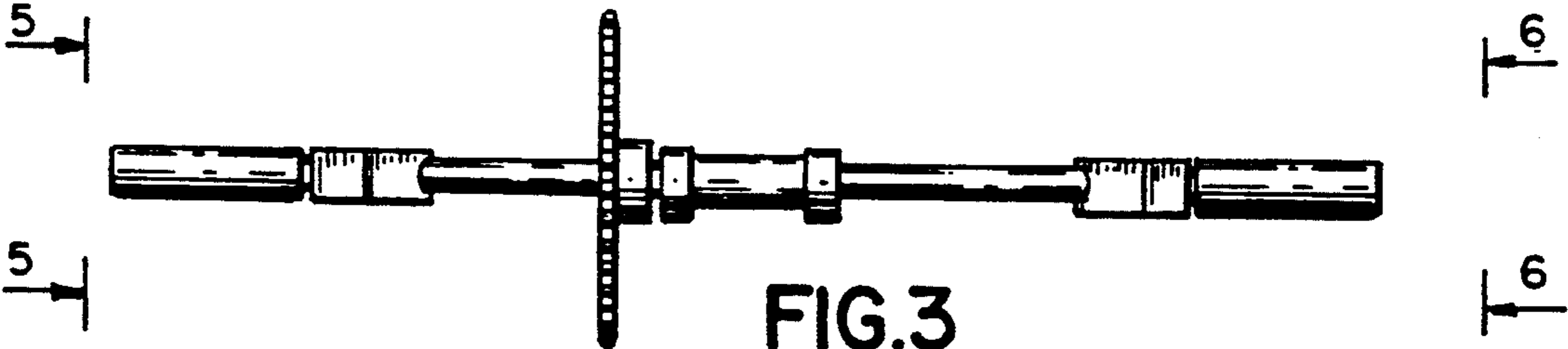

FIG. 3

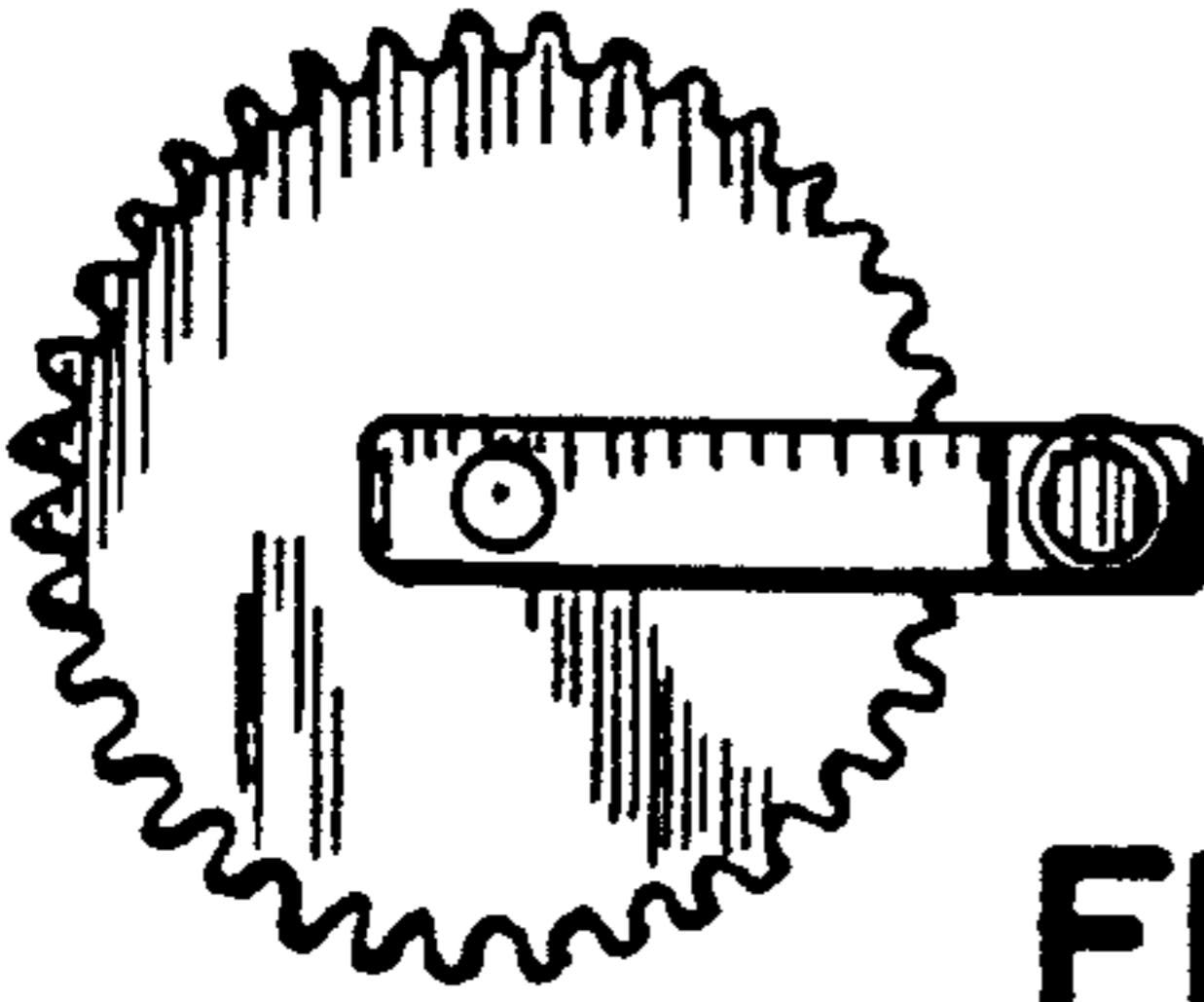

FIG. 5

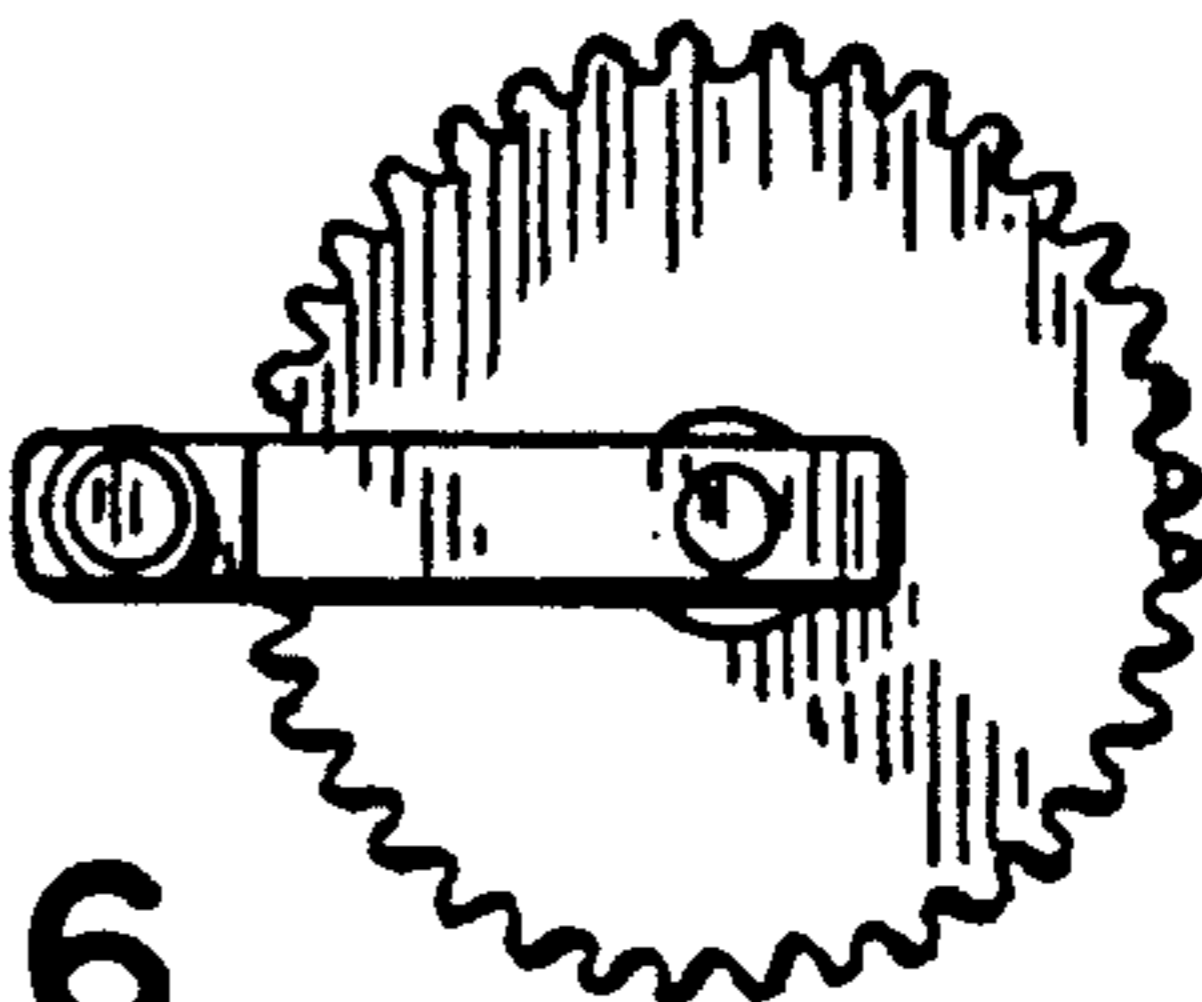

FIG. 6