



US00D341560S

# United States Patent [19]

[11] Patent Number: **Des. 341,560**

Fabris et al.

[45] Date of Patent: **\*\* Nov. 23, 1993**

[54] **VEHICLE STEERING AXLE**

D. 291,190 8/1987 Davis ..... D12/160

[75] Inventors: **Antonio A. Fabris**, Campodarsego;  
**Antonietto Raniero**, S.Andrea di  
Vigonza, both of Italy

*Primary Examiner*—Wallace R. Burke  
*Assistant Examiner*—Melody Brown  
*Attorney, Agent, or Firm*—Sughrue, Mion, Zinn,  
Macpeak & Seas

[73] Assignee: **Carraro S.p.A.**, Campodarsego, Italy

[57] **CLAIM**

[\*\*] Term: **14 Years**

The ornamental design for a vehicle steering axle, as shown and described.

[21] Appl. No.: **895,409**

**DESCRIPTION**

[22] Filed: **Jun. 11, 1992**

[52] U.S. Cl. .... **D12/160**

[58] Field of Search ..... D12/160; 301/124.2,  
301/126-130, 137

FIG. 1 is a perspective view of a vehicle steering axle showing the front, top and one end of our new design; FIG. 2 is a front elevational view thereof; FIG. 3 is a top plan view thereof; FIG. 4 is a rear elevational view thereof; FIG. 5 is a bottom plan view thereof; and, FIG. 6 is an end elevational view of said one end, the opposite end being a mirror image thereof.

[56] **References Cited**

**U.S. PATENT DOCUMENTS**

D. 246,451 11/1977 Shealy ..... D12/160

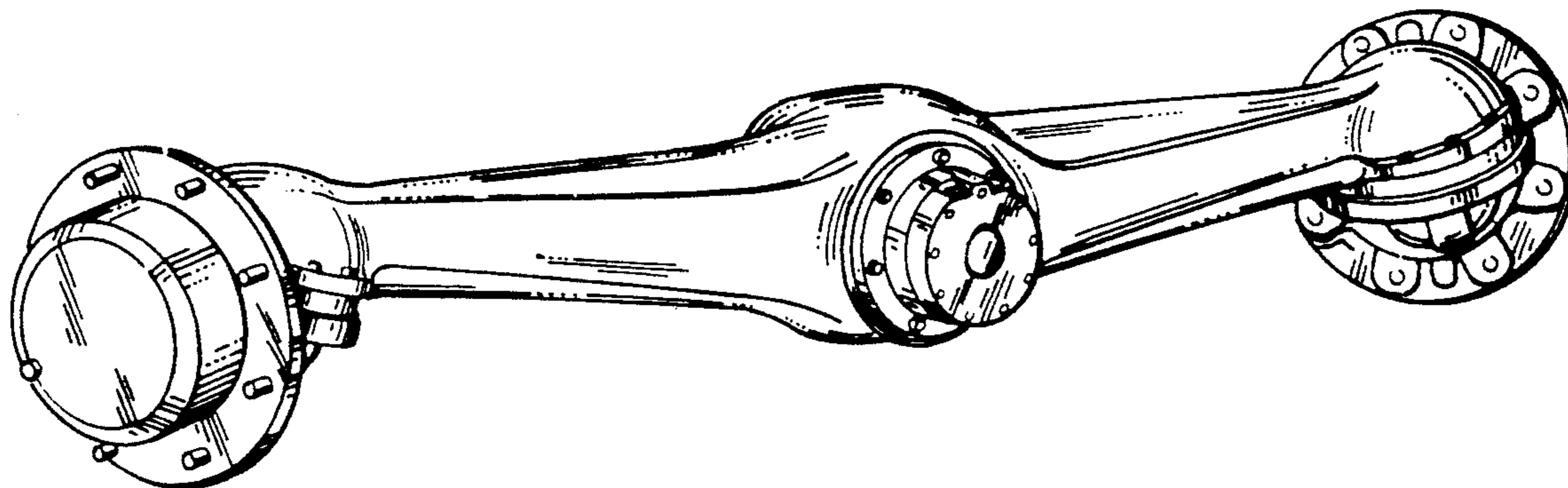

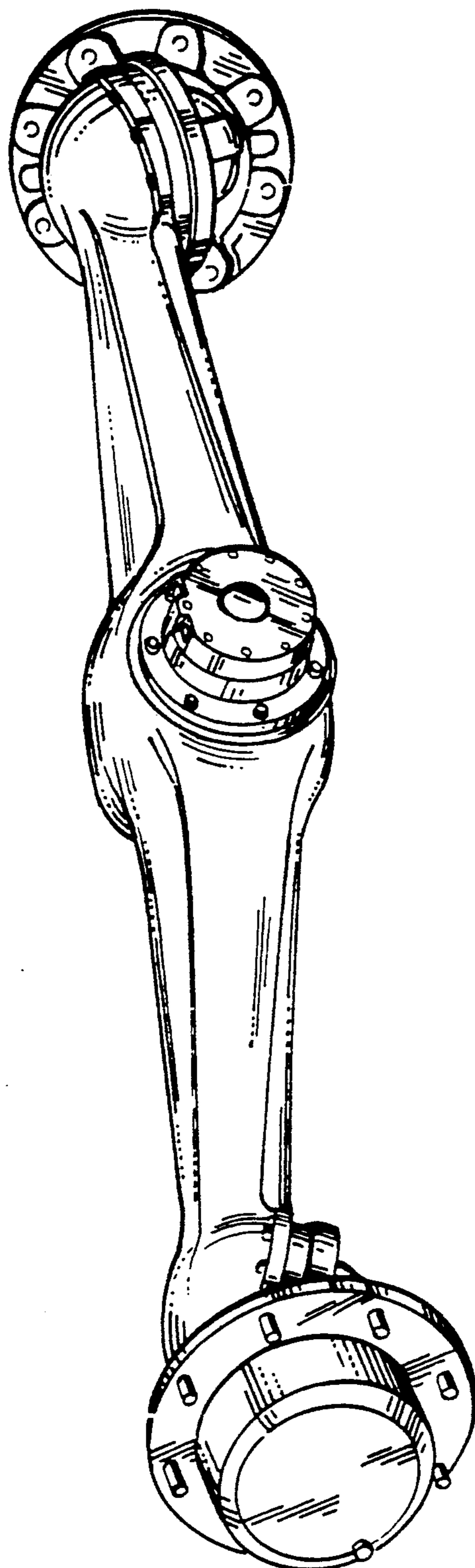

FIG. 1

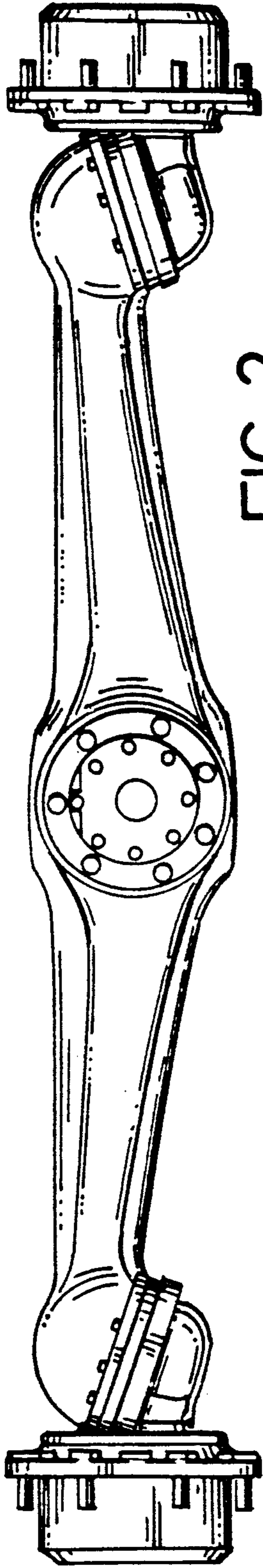

FIG. 2

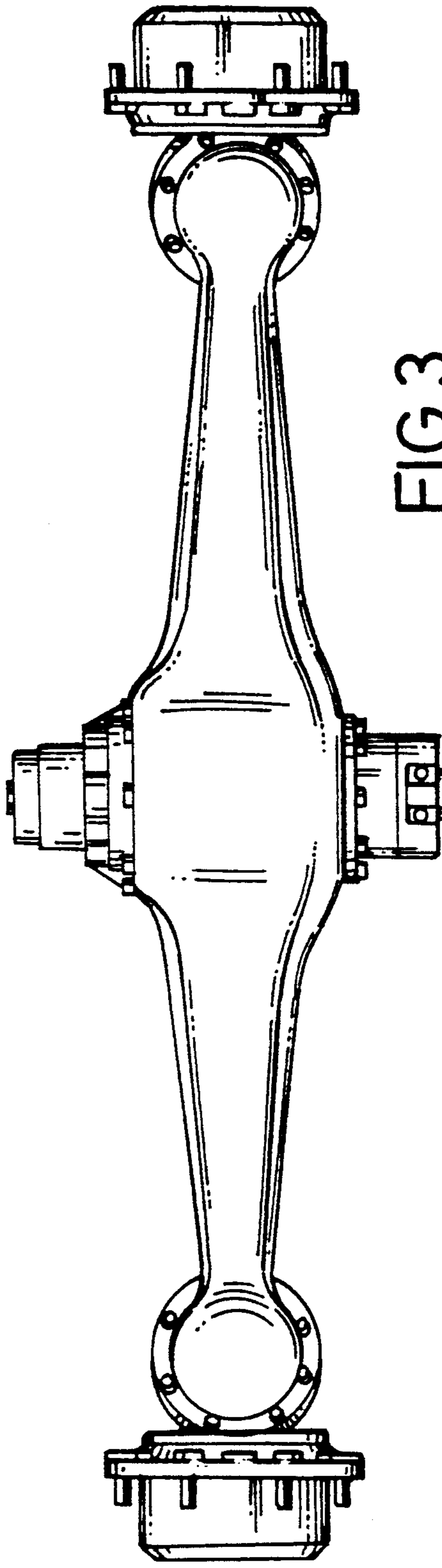

FIG. 3

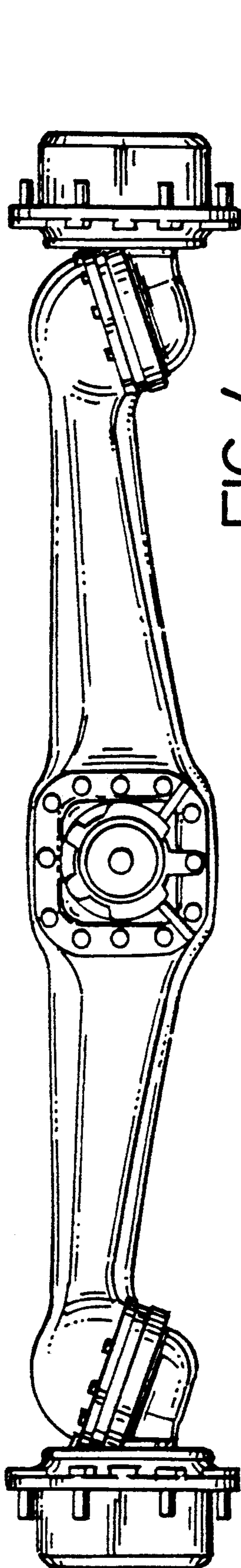

FIG. 4

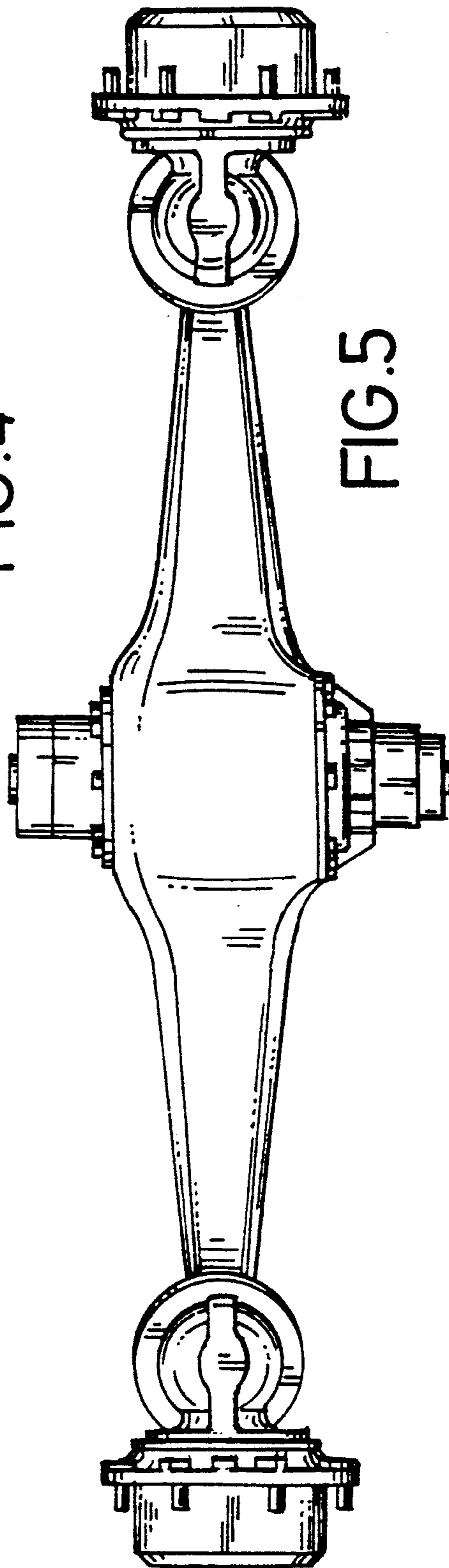

FIG. 5

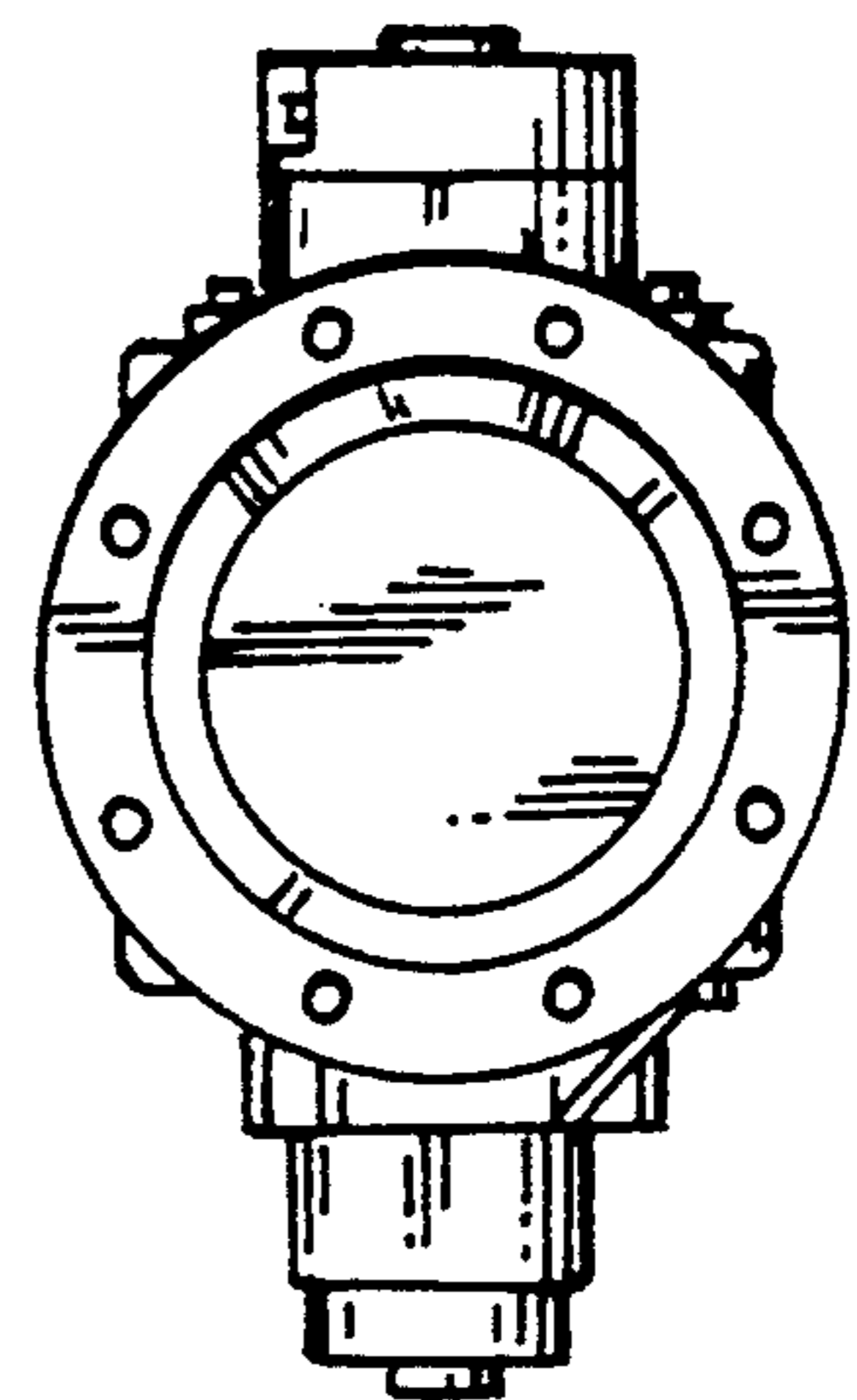

FIG. 6