



US00D341352S

United States Patent [19]

[11] Patent Number: Des. 341,352

Dawson

[45] Date of Patent: ** Nov. 16, 1993

[54] BOAT

3,500,784 3/1970 Reynolds 440/37
4,365,578 12/1982 Schellhaas 440/37

[76] Inventor: **Raymond J. Dawson**, 2/20 St. Peters Street, Northcote, Auckland, New Zealand

Primary Examiner—Kay H. Chin
Attorney, Agent, or Firm—Wenderoth, Lind & Ponack

[**] Term: 14 Years

[57] CLAIM

[21] Appl. No.: 726,682

The ornamental design for a boat, as shown and described.

[22] Filed: Jul. 8, 1991

DESCRIPTION

[30] Foreign Application Priority Data

Jan. 8, 1991 [NZ] New Zealand 23675
[52] U.S. Cl. D12/305; D12/309
[58] Field of Search D12/300, 305, 309, 314;
440/37

FIG. 1 is a perspective view of a boat showing my new design in a ski configuration;
FIG. 2 is a side elevation view thereof;
FIG. 3 is a front elevation view thereof;
FIG. 4 is a top plan view thereof;
FIG. 5 is a side elevation view of the boat in a hydrofoil configuration;
FIG. 6 is a front elevation view thereof;
FIG. 7 is a top plan view thereof;
FIG. 8 is a side elevation view of the boat in a hull only configuration;
FIG. 9 is a front elevation view thereof, and,
FIG. 10 is a top plan view thereof.

[56] References Cited

U.S. PATENT DOCUMENTS

D. 226,783 4/1973 Lewis D12/305
D. 235,198 5/1975 Preston D12/305
D. 313,584 1/1991 Linebaugh D12/305
2,996,030 8/1961 Lornson 440/37

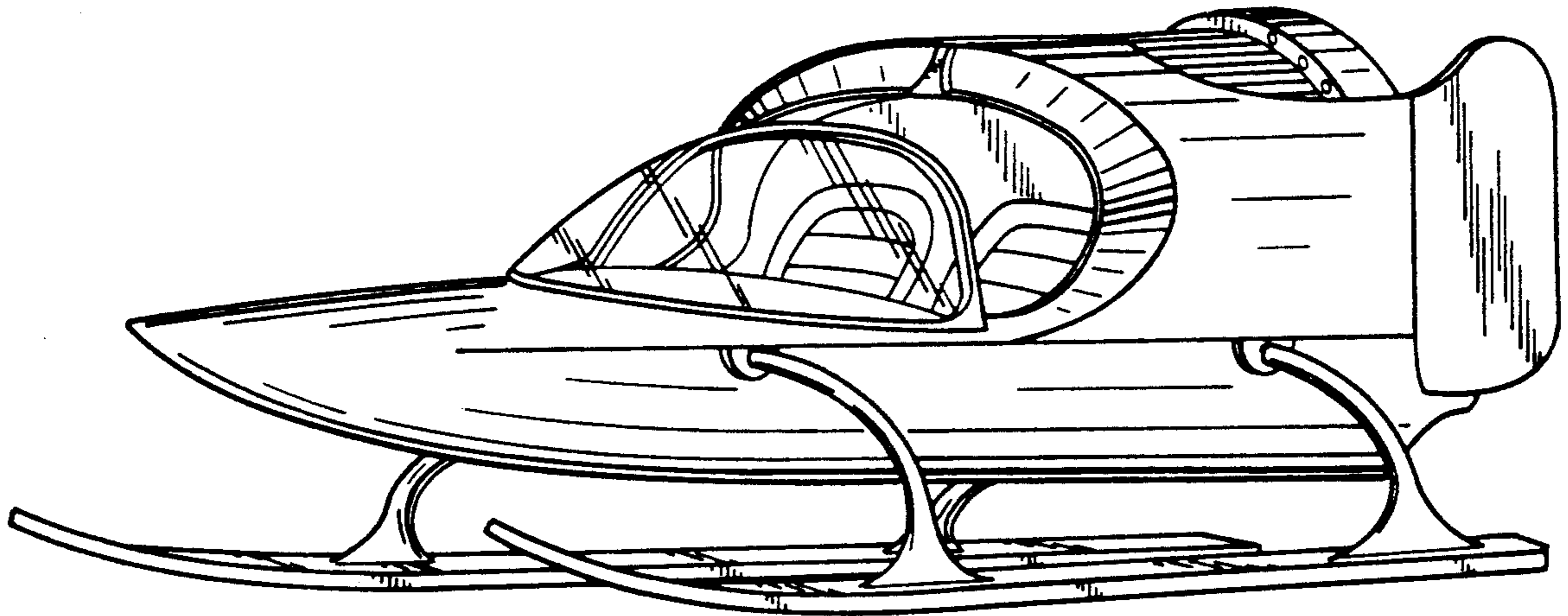

FIG. 1

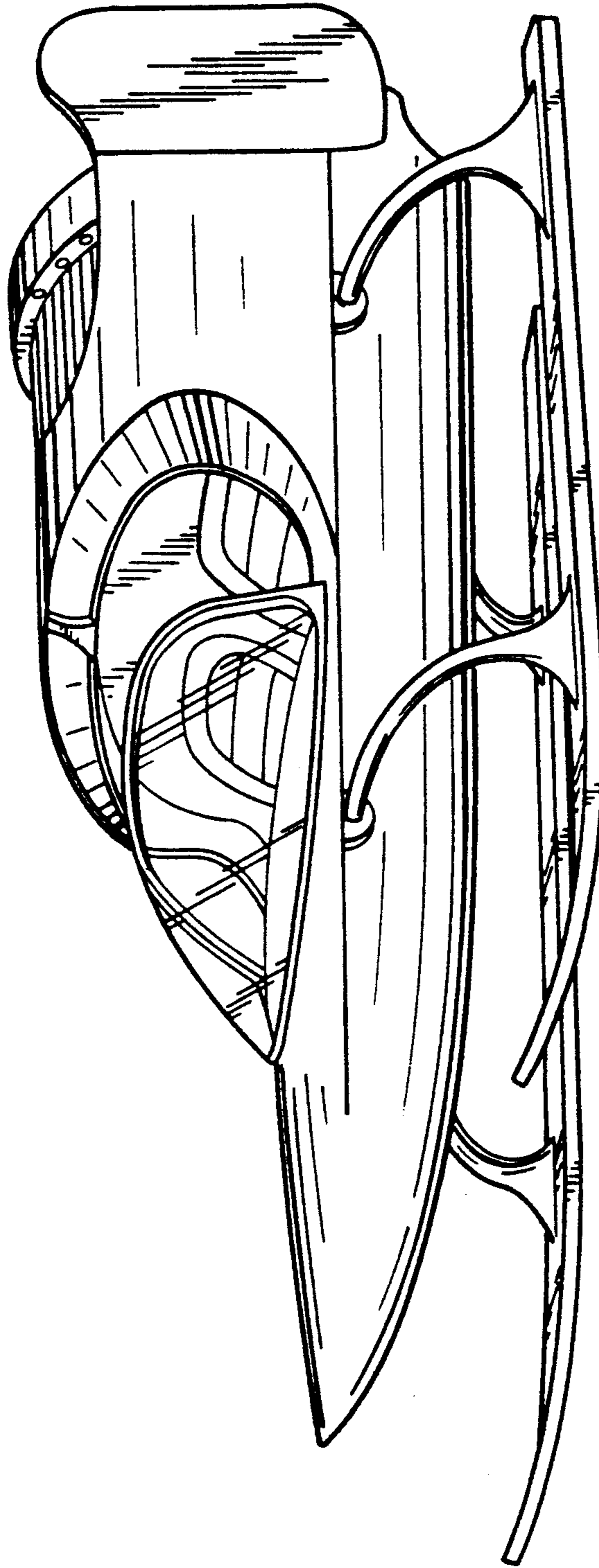

FIG. 3

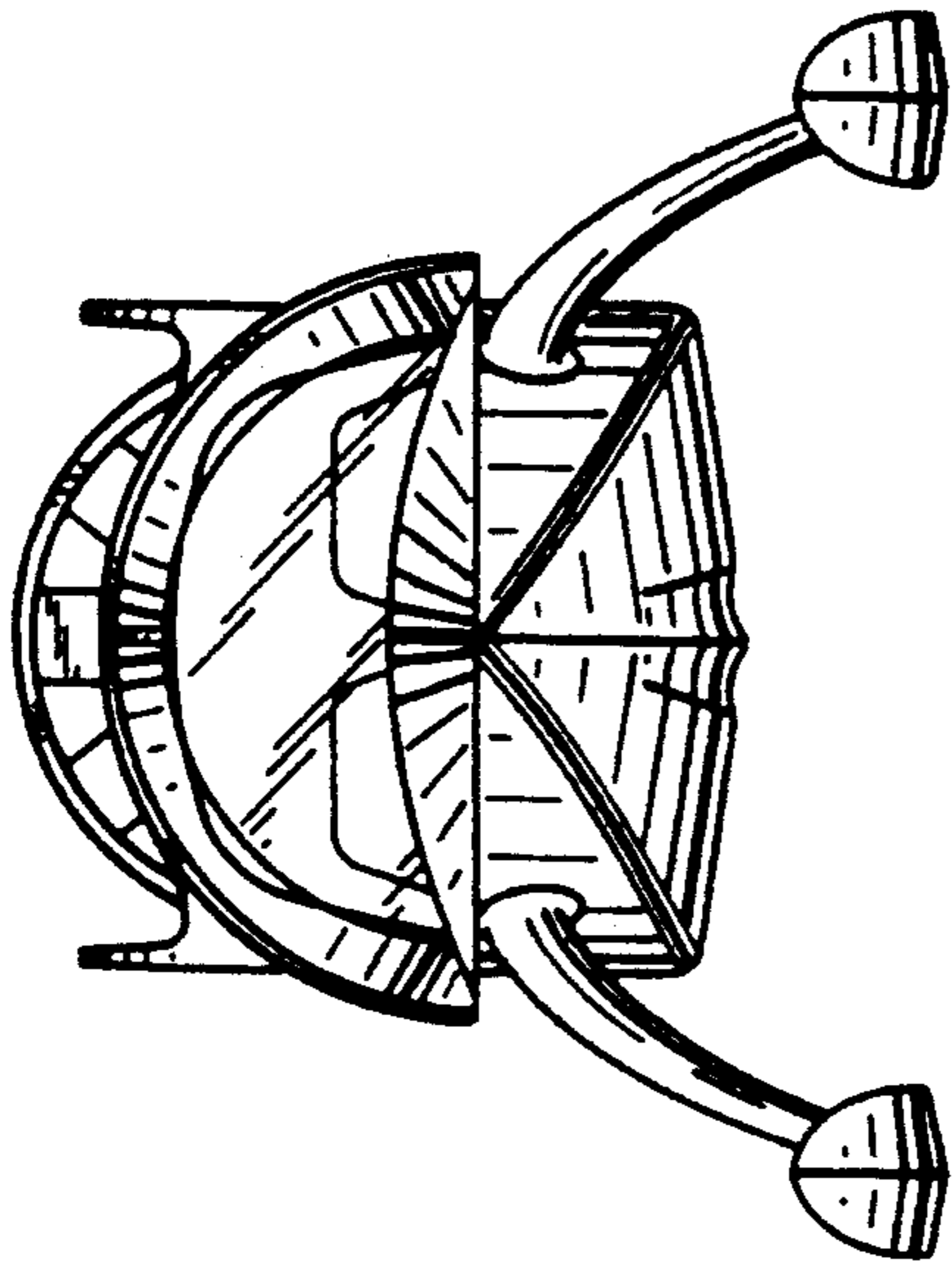

FIG. 2

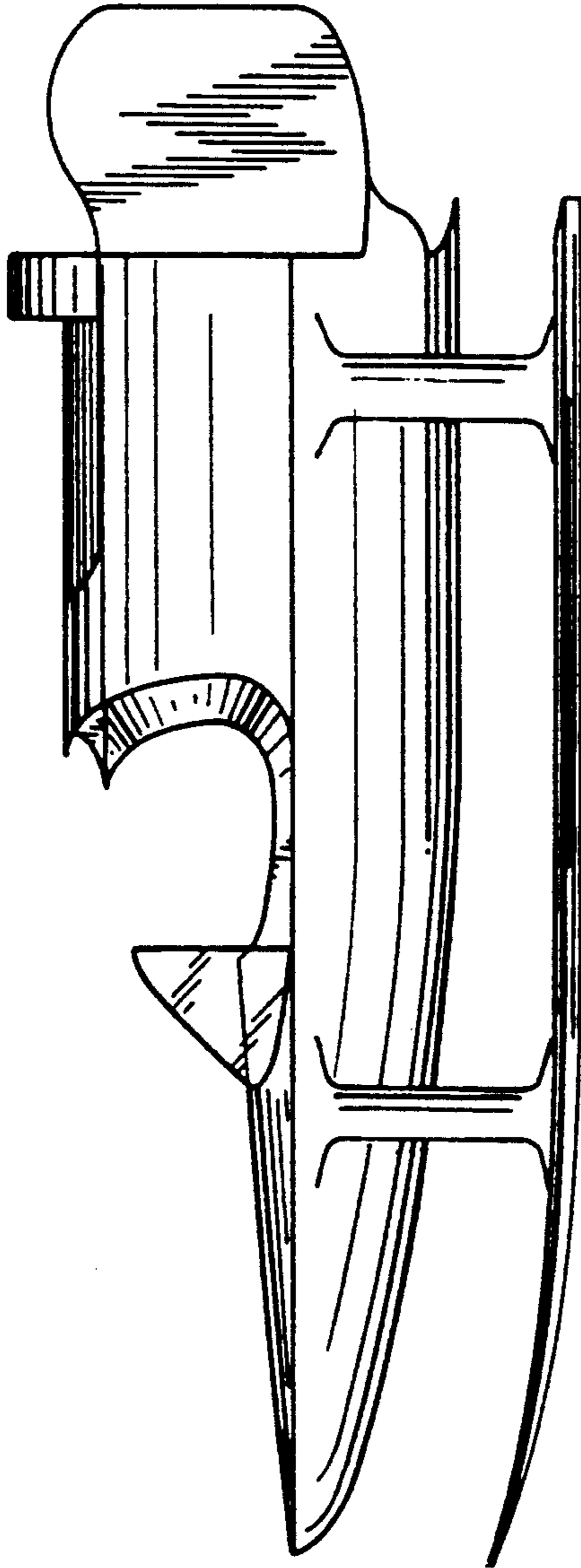

FIG. 4

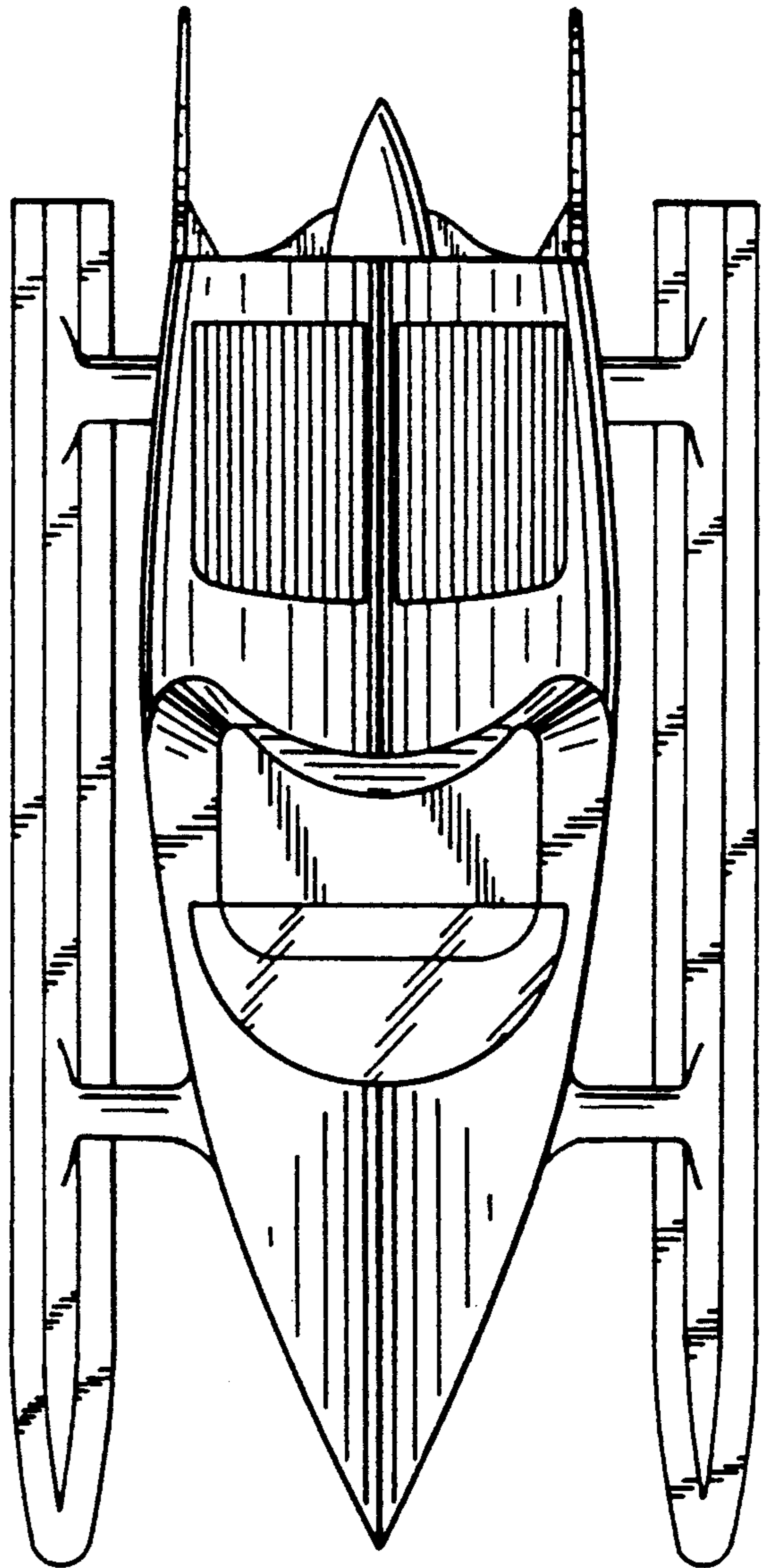

FIG. 6

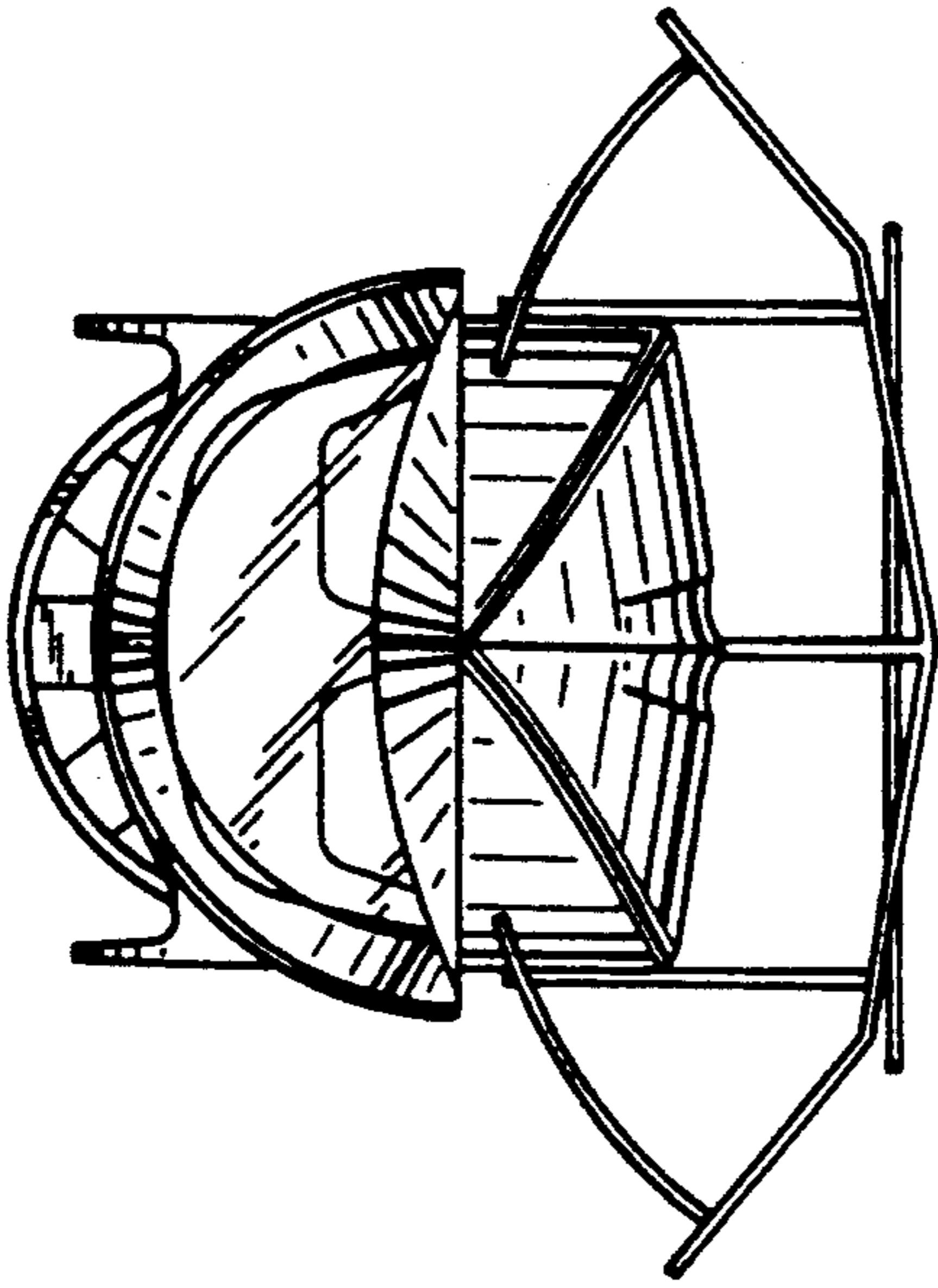

FIG. 5

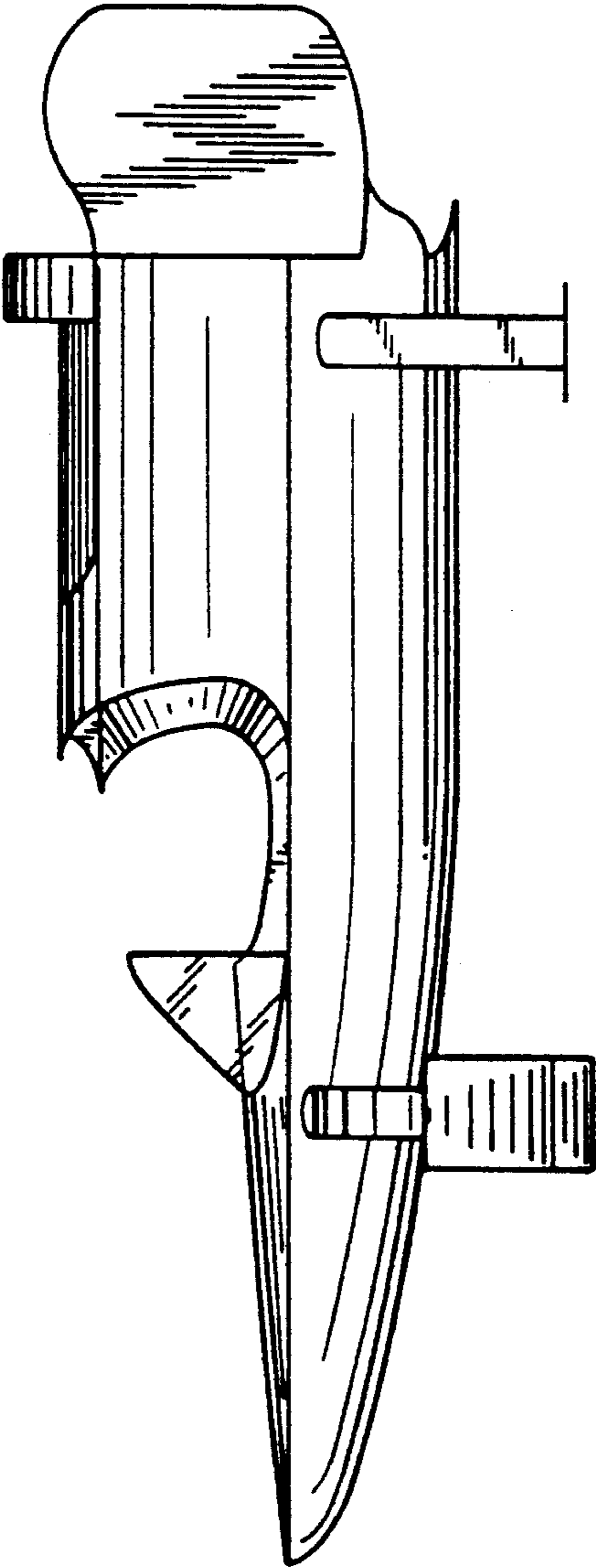

FIG. 7

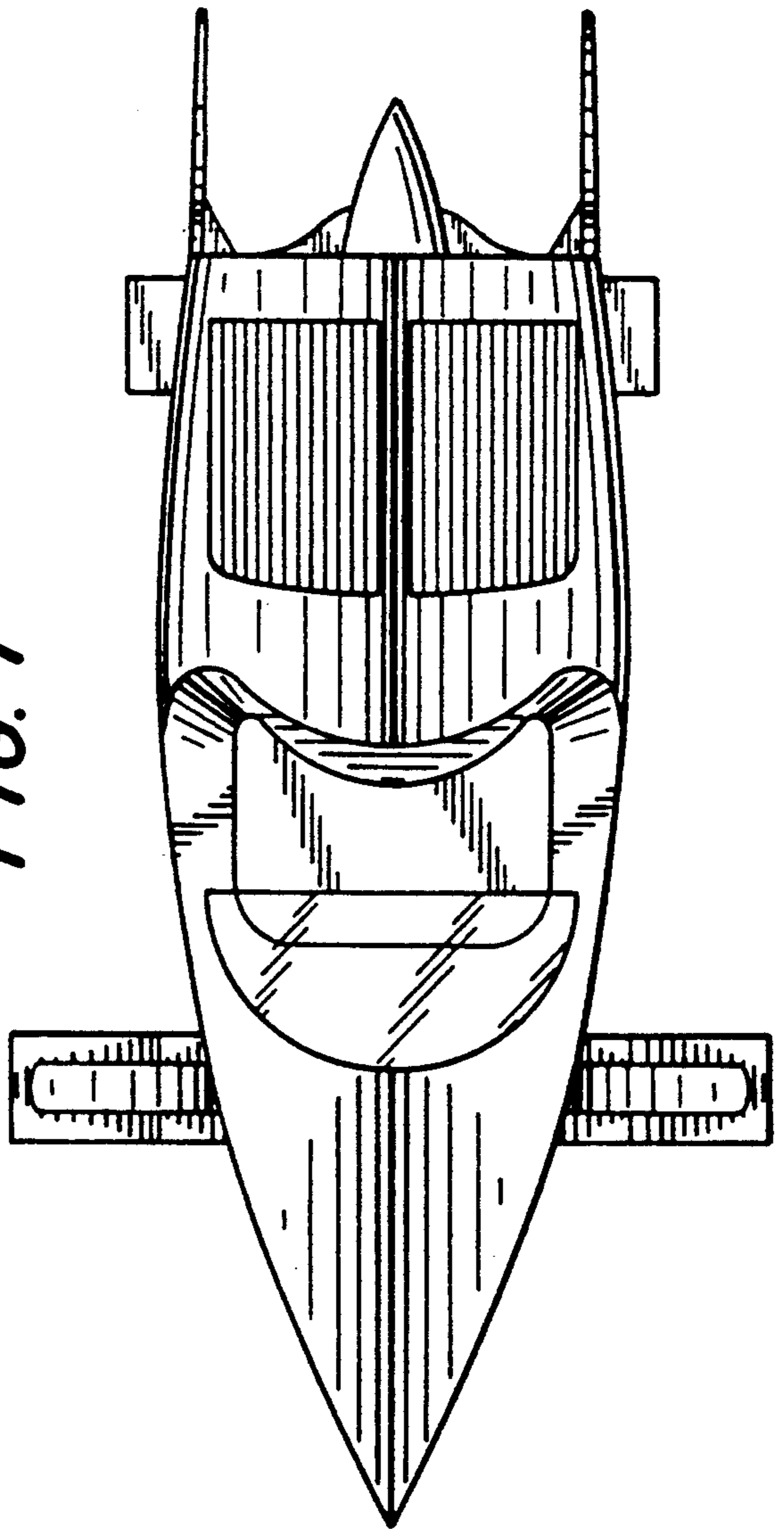

FIG. 9

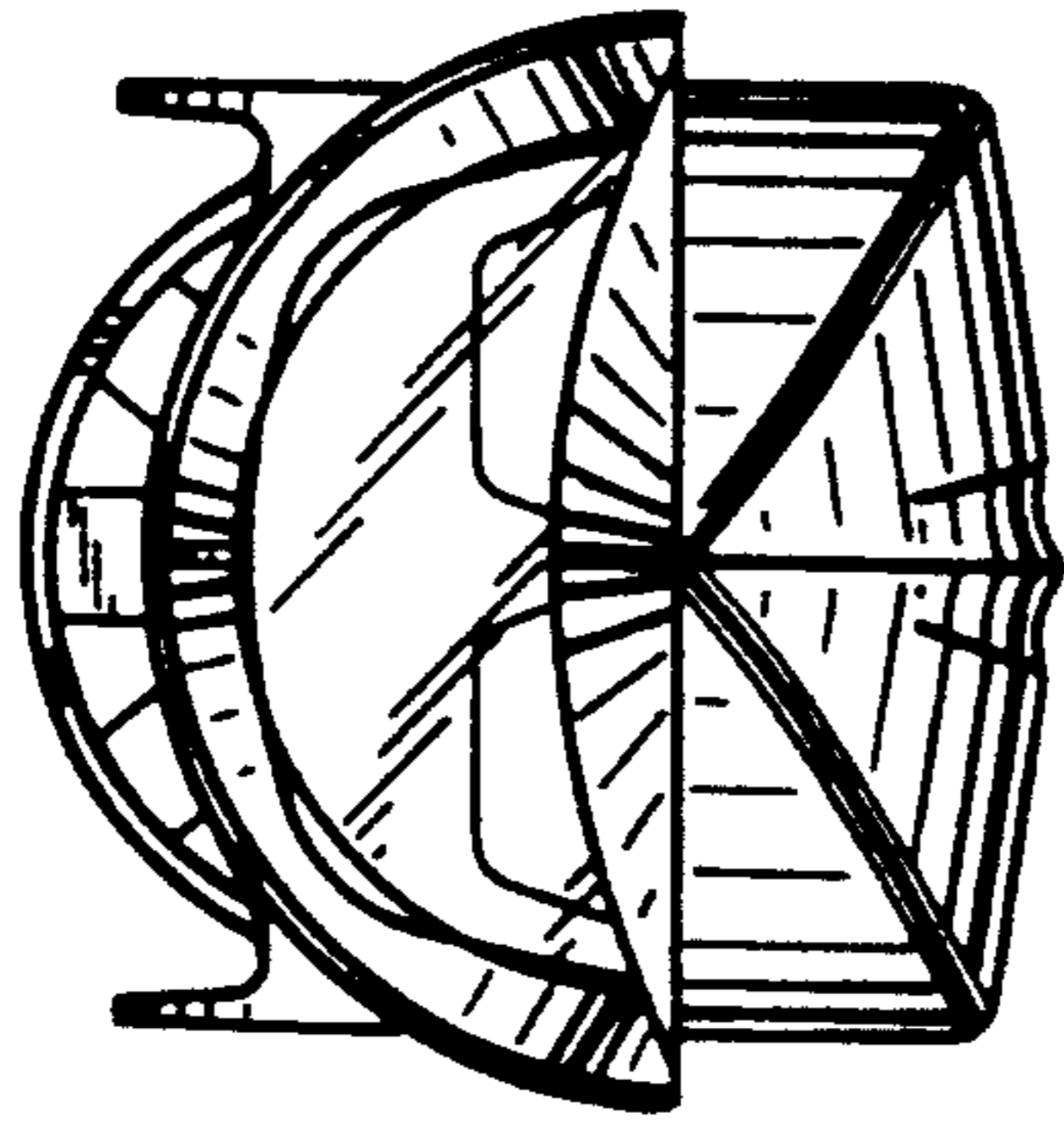

FIG. 8

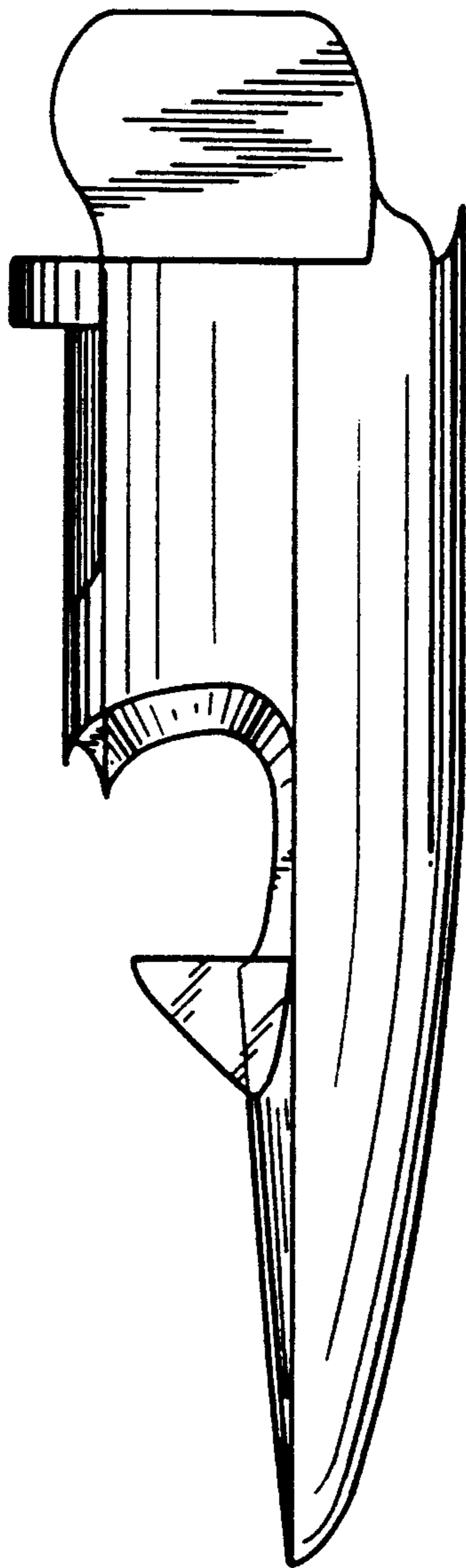

FIG. 10

