



US00D341349S

United States Patent [19]

[11] Patent Number: Des. 341,349

Shtrowise

[45] Date of Patent: ** Nov. 16, 1993

[54] LUGGAGE BOX FOR BICYCLES

4,460,114 7/1984 Grenier 224/32 A

[76] Inventor: Aharon Shtrowise, 20 Shilder Street,
Tel Aviv, Israel

Primary Examiner—Wallace R. Burke
Assistant Examiner—M. Brown
Attorney, Agent, or Firm—Elliott N. Kramsky

[**] Term: 14 Years

[57] CLAIM

[21] Appl. No.: 783,089

The ornamental design for a luggage box for bicycles,
as shown.

[22] Filed: Oct. 28, 1991

[52] U.S. Cl. D12/158

[58] Field of Search D12/158; 224/32 A, 32 R,
224/30 R, 30 A, 31, 35

DESCRIPTION

[56] References Cited

U.S. PATENT DOCUMENTS

- D. 271,758 7/1983 Ervin D12/158
- D. 276,907 12/1984 Cunningham D12/158
- D. 279,369 6/1985 Van Vlandren D12/158
- D. 282,061 1/1986 Abe D12/158

FIG. 1 is a perspective view of the luggage box for bicycles showing my new design;
FIG. 2 is a rear elevation view of the box;
FIG. 3 is a front elevation view of the box;
FIG. 4 is a top elevation view of the box;
FIG. 5 is a left hand elevation view of the box; and,
FIG. 6 is a right hand elevation view of the box, said view including the bottom of the box.

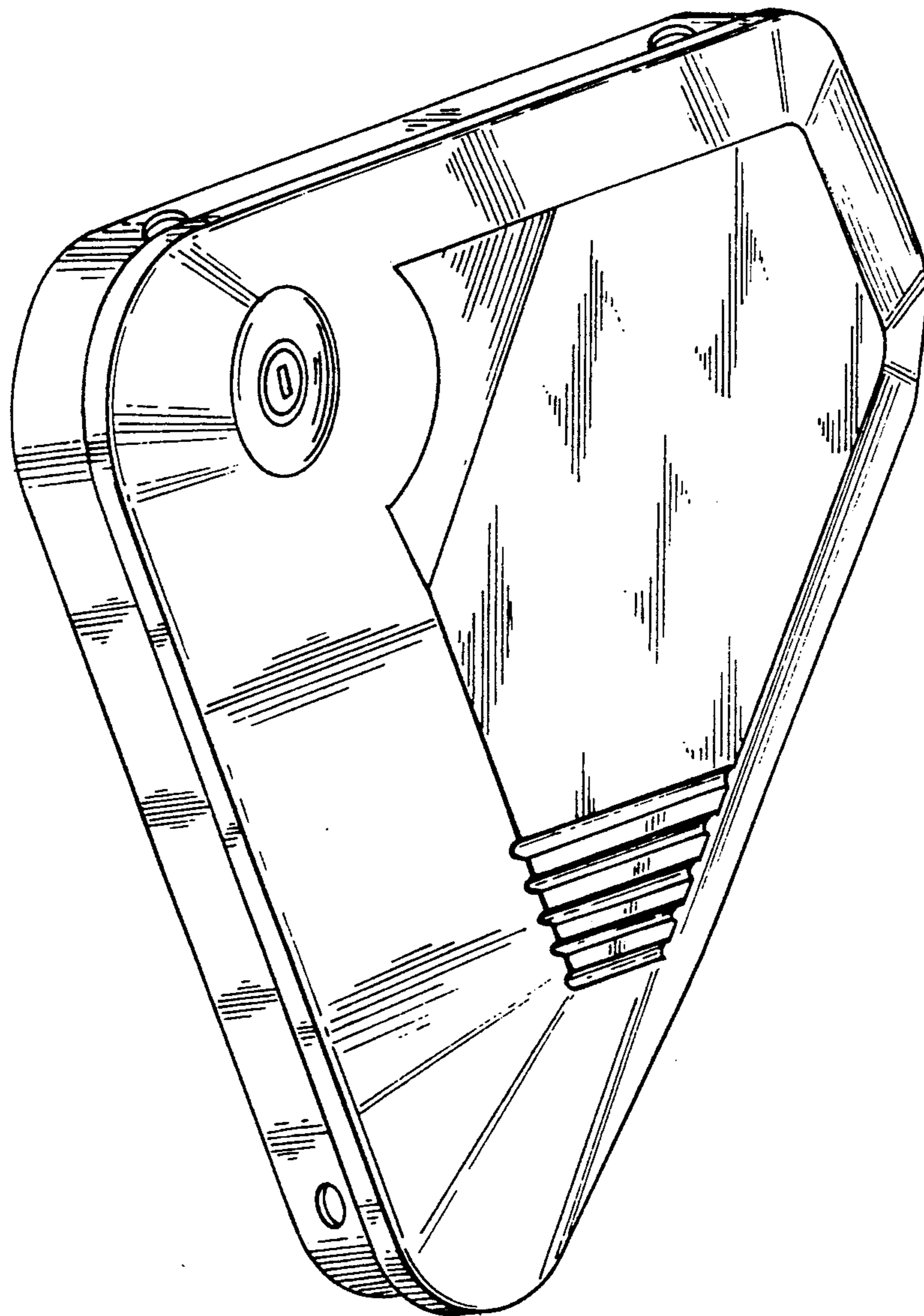

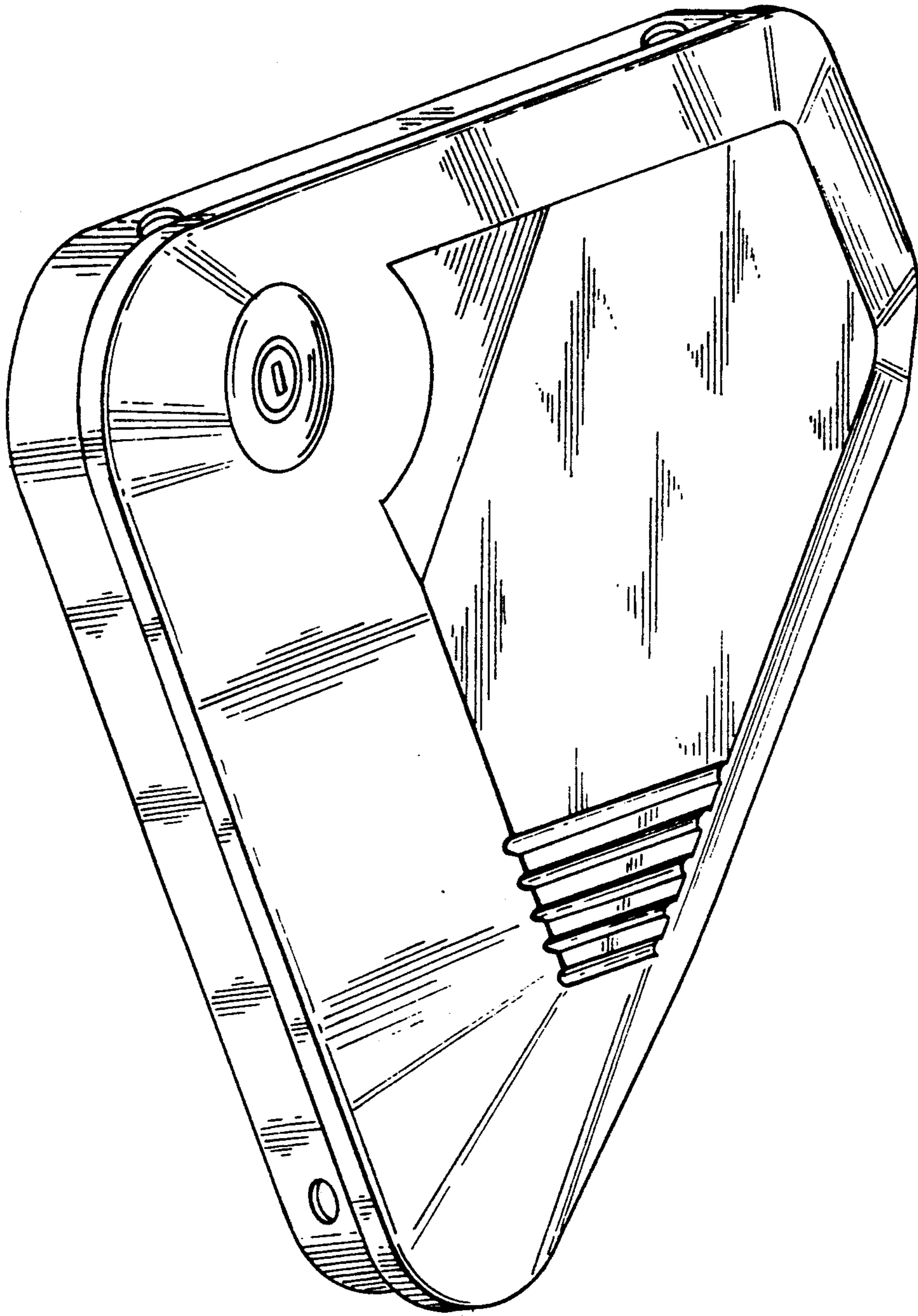

FIG. 1

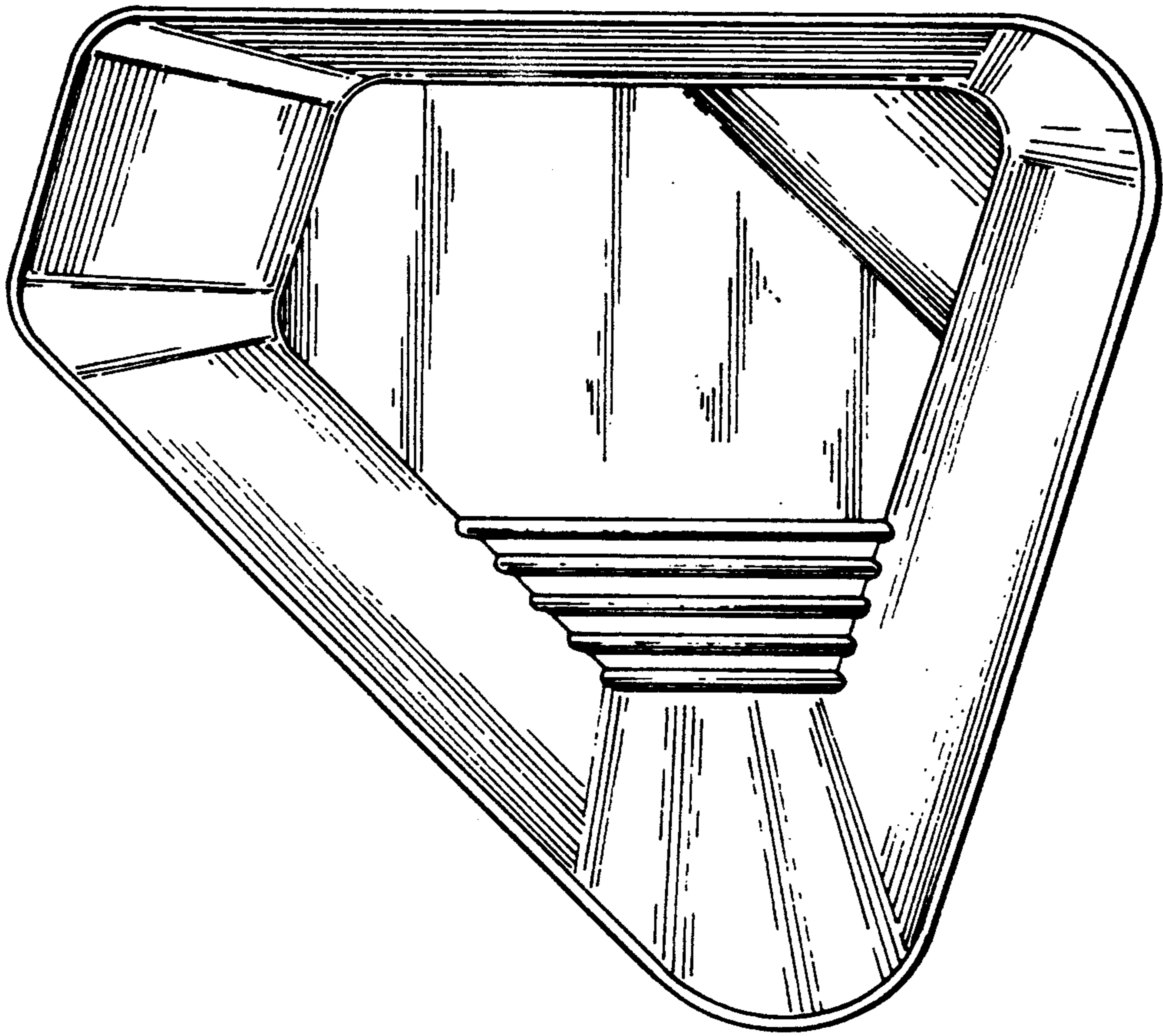

FIG. 2

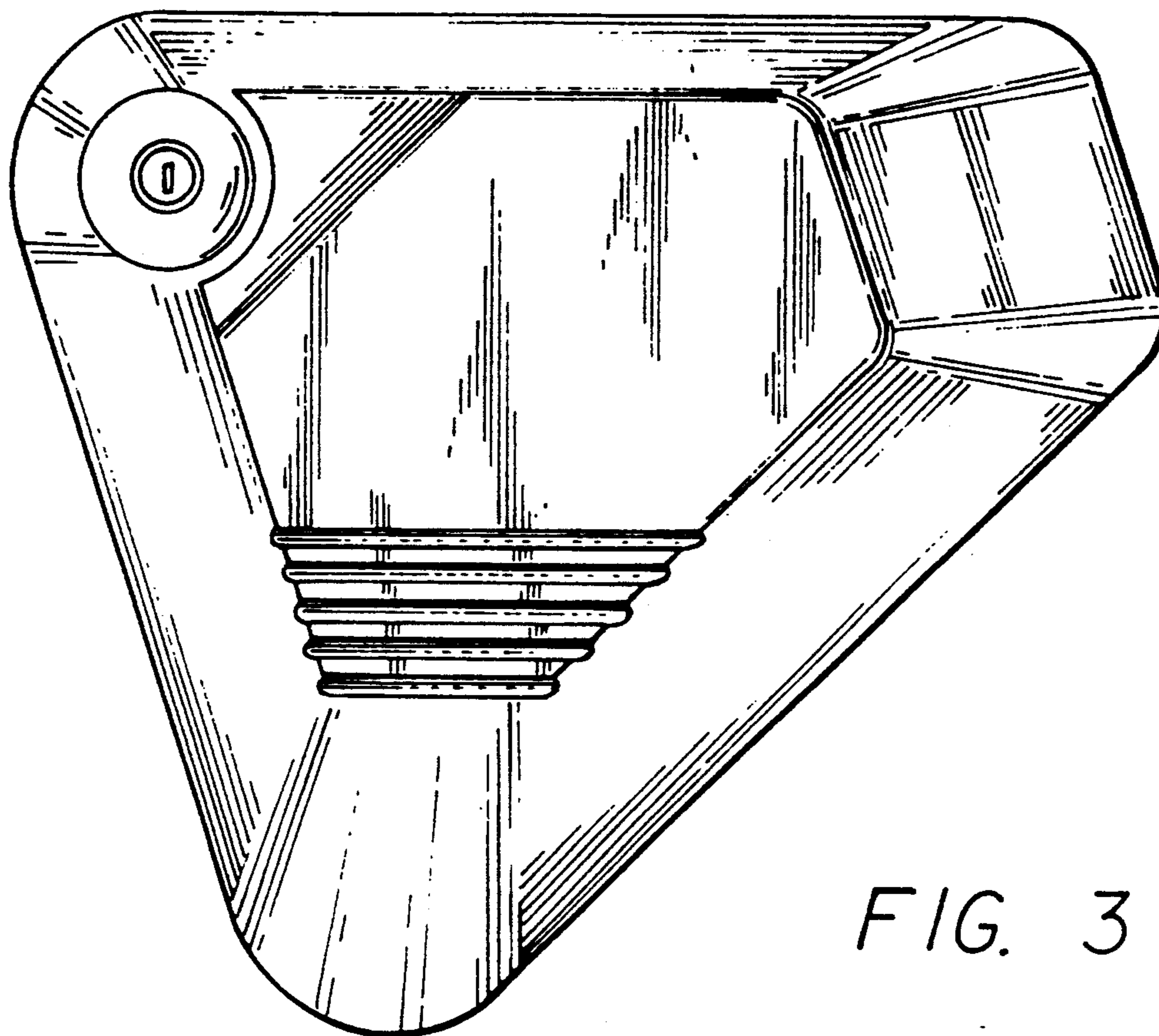

FIG. 3

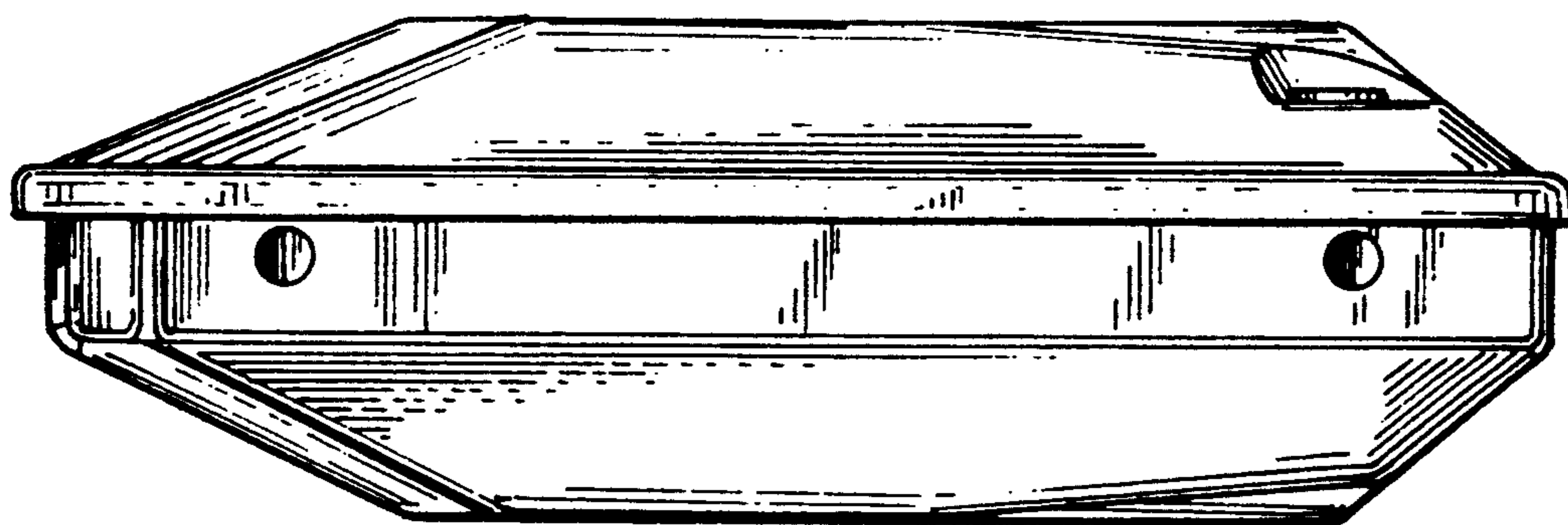

FIG. 4

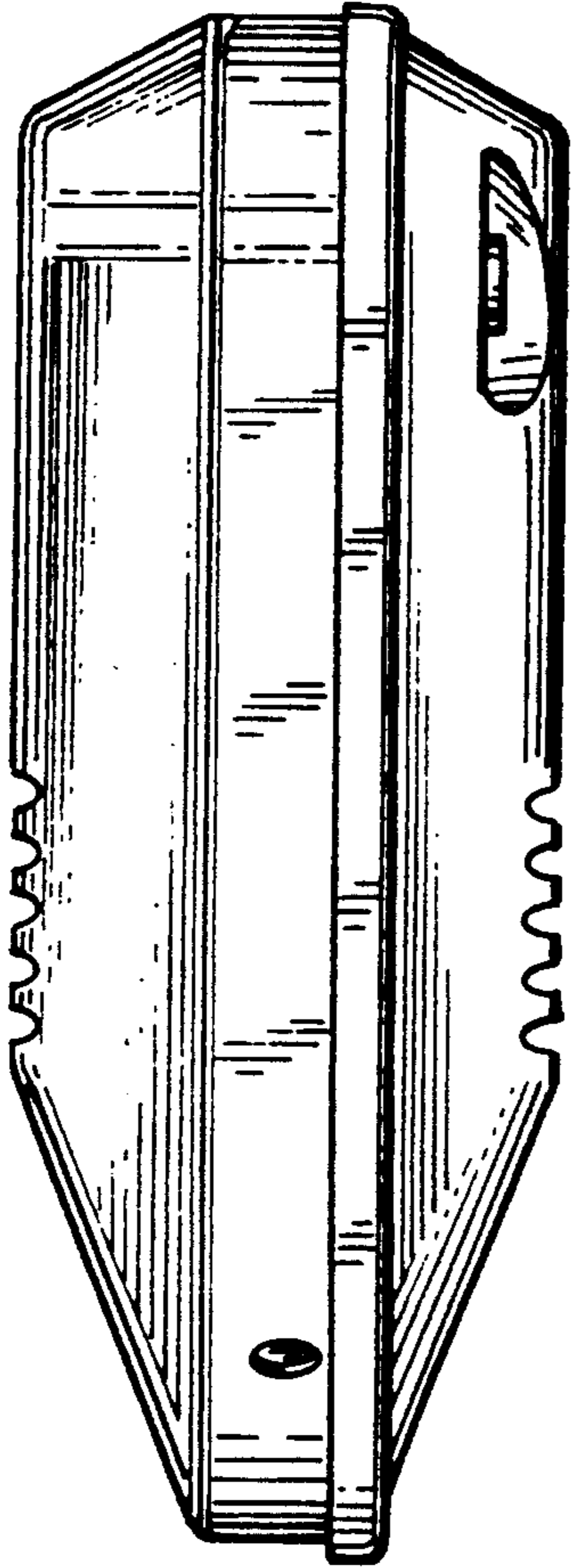

FIG. 5

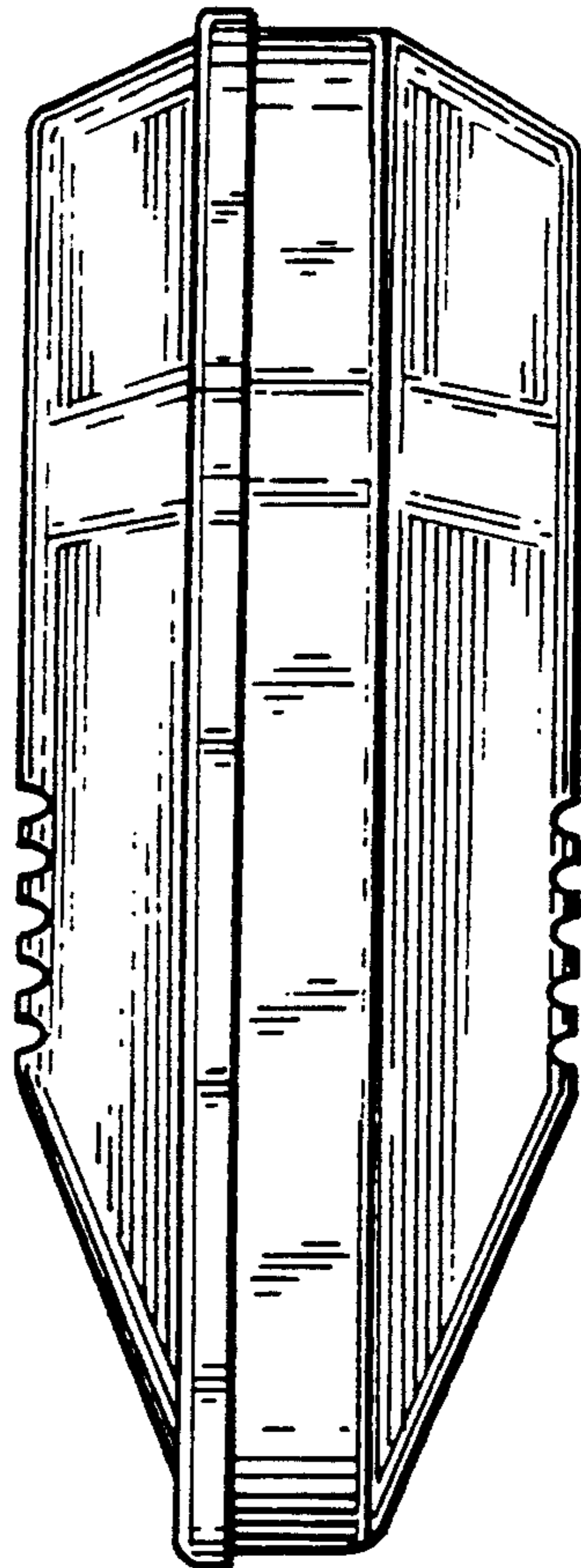

FIG. 6