



US00D341107S

United States Patent [19]

[11] Patent Number: **Des. 341,107**

Okura et al.

[45] Date of Patent: **** Nov. 9, 1993**

[54] **AUTOMOBILE**

[75] Inventors: **Tomoyuki Okura, Nerima; Tsuyoshi Nishimura, Asaka, both of Japan**

[73] Assignee: **Honda Giken Kogyo Kabushiki Kaisha, Tokyo, Japan**

[**] Term: **14 Years**

[21] Appl. No.: **701,975**

[22] Filed: **May 16, 1991**

[52] U.S. Cl. **D12/91**

[58] Field of Search **D12/91; 296/185**

[56] **References Cited**

U.S. PATENT DOCUMENTS

- D. 298,521 11/1988 Ui et al. D12/91
- D. 311,709 10/1990 Fujimura et al. D12/91

OTHER PUBLICATIONS

Road and Track, Nov./1990, p. 186, Nissan Pulsar GTI-R Automobile, upper left side of page.

Primary Examiner—James M. Gandy
Attorney, Agent, or Firm—Lyon & Lyon

[57] **CLAIM**

The ornamental design for an automobile, as shown and described.

DESCRIPTION

FIG. 1 is a top plan view of an automobile showing our new design;
 FIG. 2 is a left side elevation view thereof and the right side elevation view thereof is the same except reversed from left to right;
 FIG. 3 is a front elevation view thereof;
 FIG. 4 is a rear elevation view thereof; and,
 FIG. 5 is a left side rear perspective view thereof.

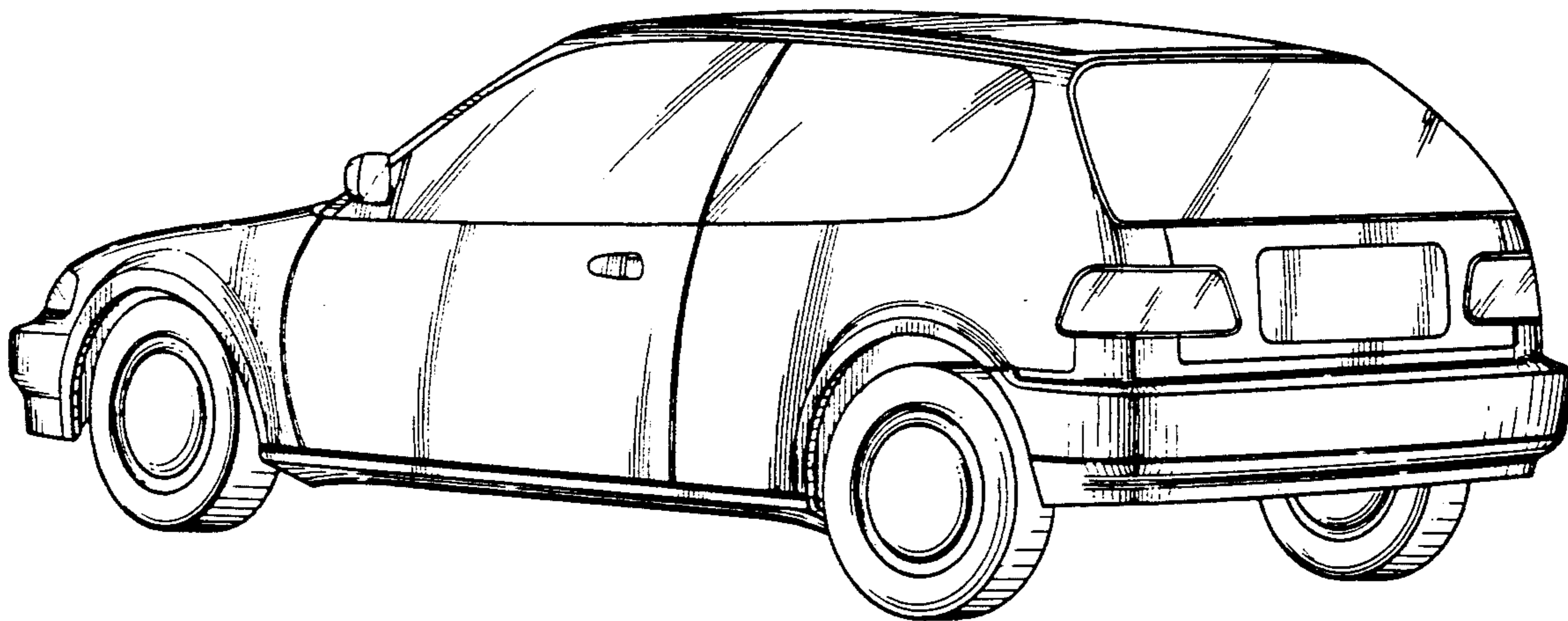

FIG. 1.

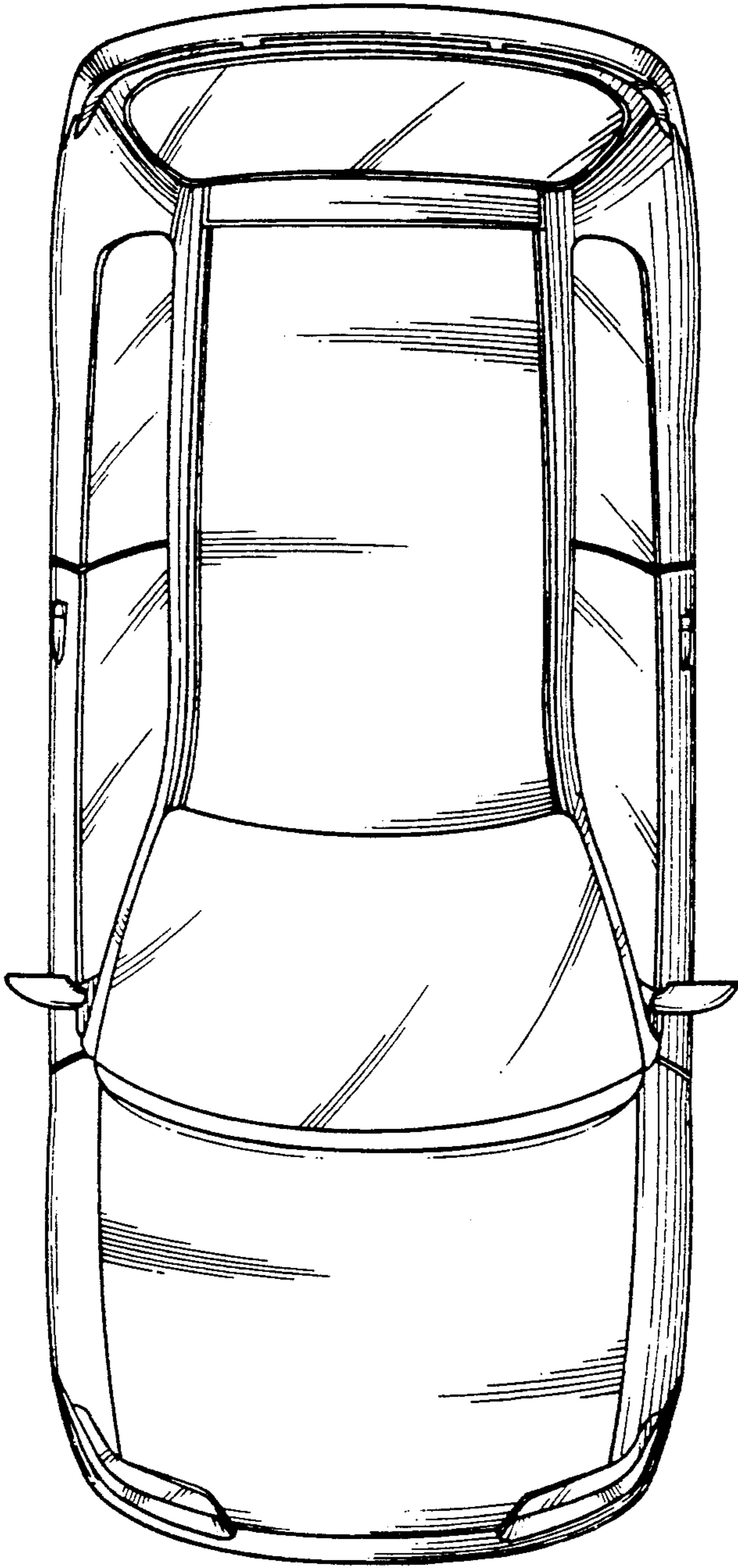
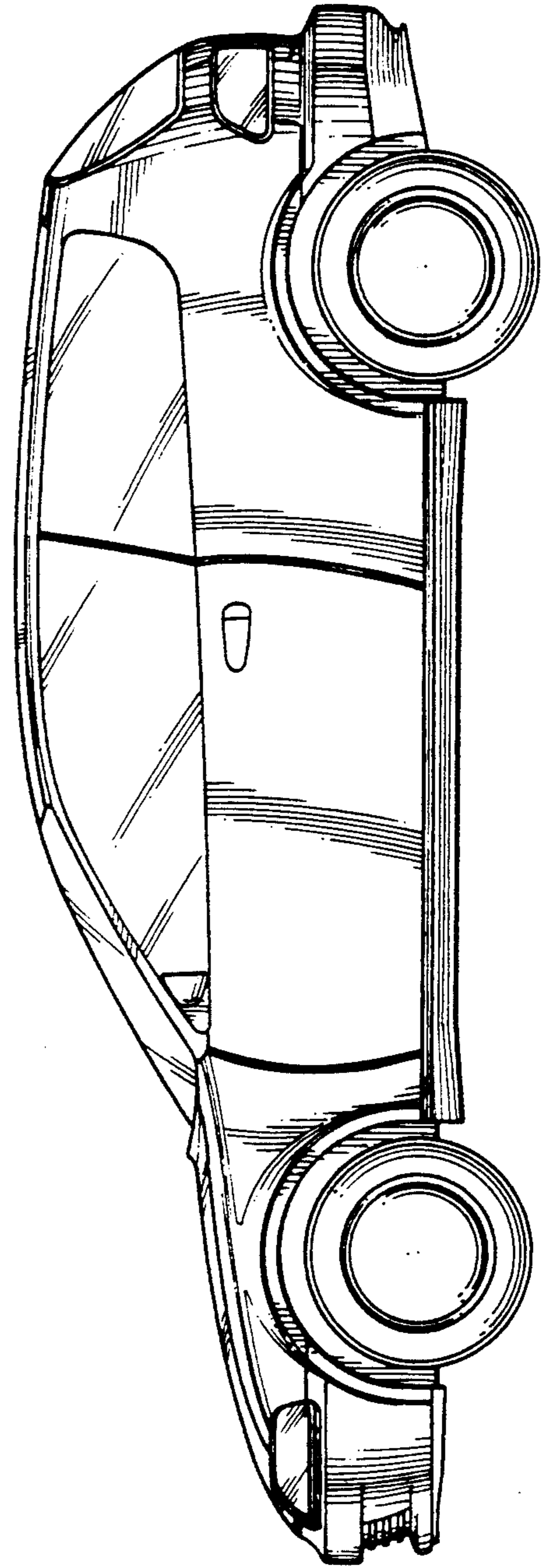

FIG. 2.



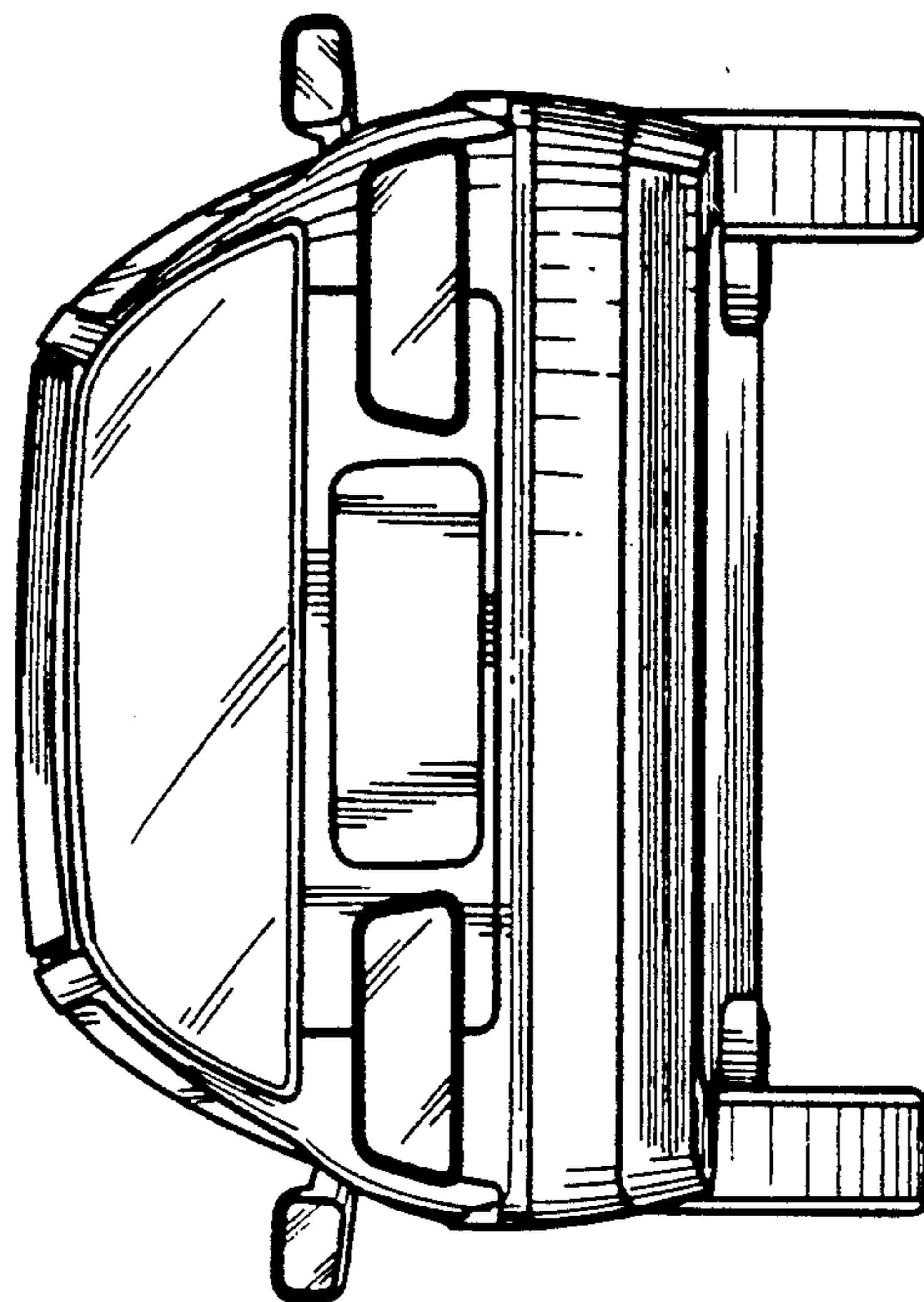

FIG. 4.

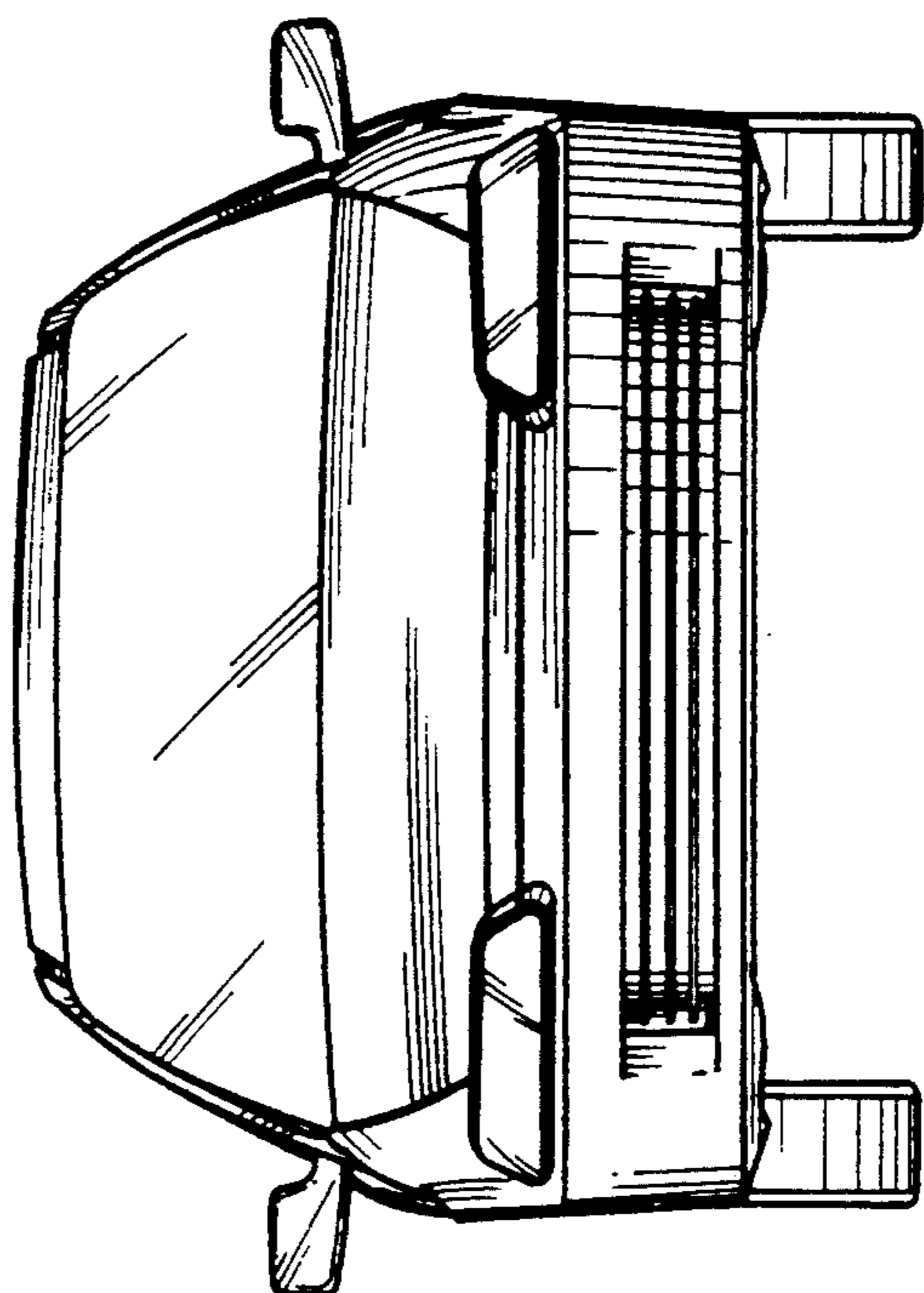

FIG. 3.

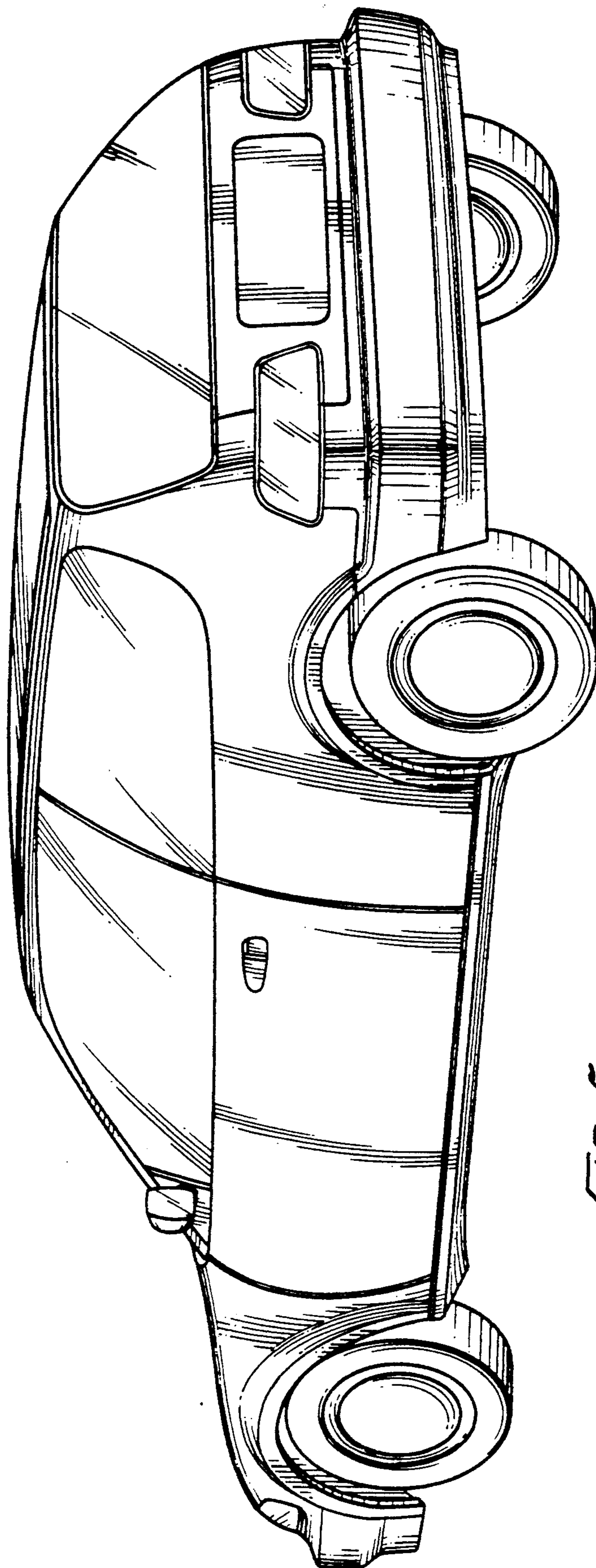

FIG. 5.