



US00D341016S

United States Patent [19]

[11] Patent Number: **Des. 341,016**

Wada et al.

[45] Date of Patent: **** Nov. 2, 1993**

[54] **OVER-LOAD CUTOUT DEVICE FOR HAND-OPERATED, HOISTING AND PULLING MACHINE**

New Equip. Digest, Oct. 1989, p. 39, "Duff-Norton" Economy Model Hoists & Pullers.

[75] Inventors: **Yasuo Wada; Haruo Kubota; Yoshio Ueno**, all of Osaka-Sayama, Japan

Primary Examiner—Kay H. Chin
Attorney, Agent, or Firm—Stevens, Davis, Miller & Mosher

[73] Assignee: **Elephant Chain Block Company Limited**, Osaka, Japan

[57] **CLAIM**

[**] Term: **14 Years**

The ornamental design for over-load cutout device for hand-operated, hoisting and pulling machine, as shown and described.

[21] Appl. No.: **813,413**

DESCRIPTION

[22] Filed: **Dec. 30, 1991**

FIG. 1 is a front view of the over-load cutout device for hand-operated, hoisting and pulling machine of our new design;

[30] **Foreign Application Priority Data**

Dec. 3, 1991 [JP] Japan 3-36617

FIG. 2 is a right-side elevational view thereof;

[52] U.S. Cl. **D34/35; D34/33**

FIG. 3 is a rear view thereof;

[58] Field of Search **D34/28, 33, 35;**

FIG. 4 is a plan view thereof; and,

254/380, 382, 384, 335, 372

FIG. 5 is a sectional view taken on line A—A in FIG. 1.

[56] **References Cited**

PUBLICATIONS

New Equip. Digest, Feb. 1992, p. 25, "Ingersoll-Rand" Material Handling, Lever Chin Hoists.

A left-side elevational view of the over-load cutout device for hand-operated hoisting and pulling machine of our design is a mirror image of the right-side elevational view shown in FIG. 1; and,

A bottom view thereof is a mirror image of the plan view shown in FIG. 4.

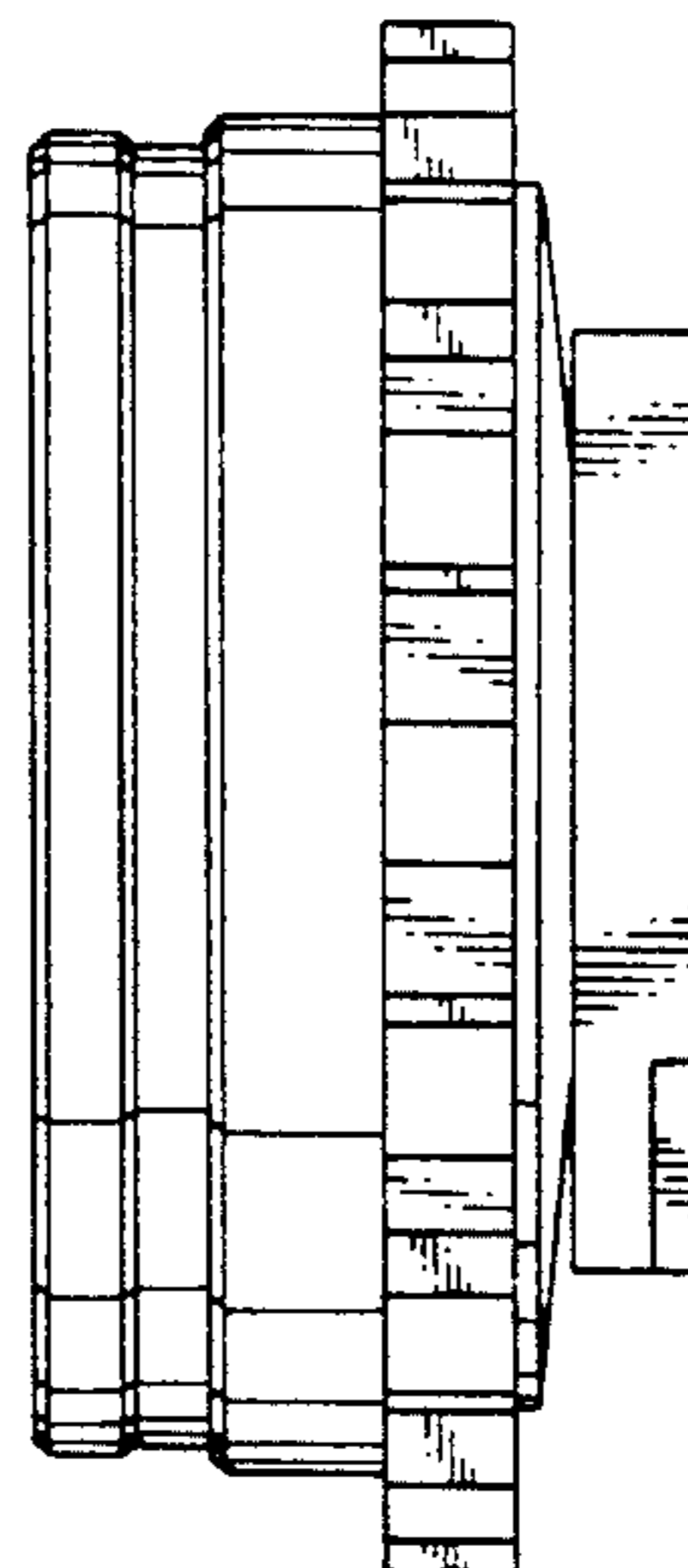
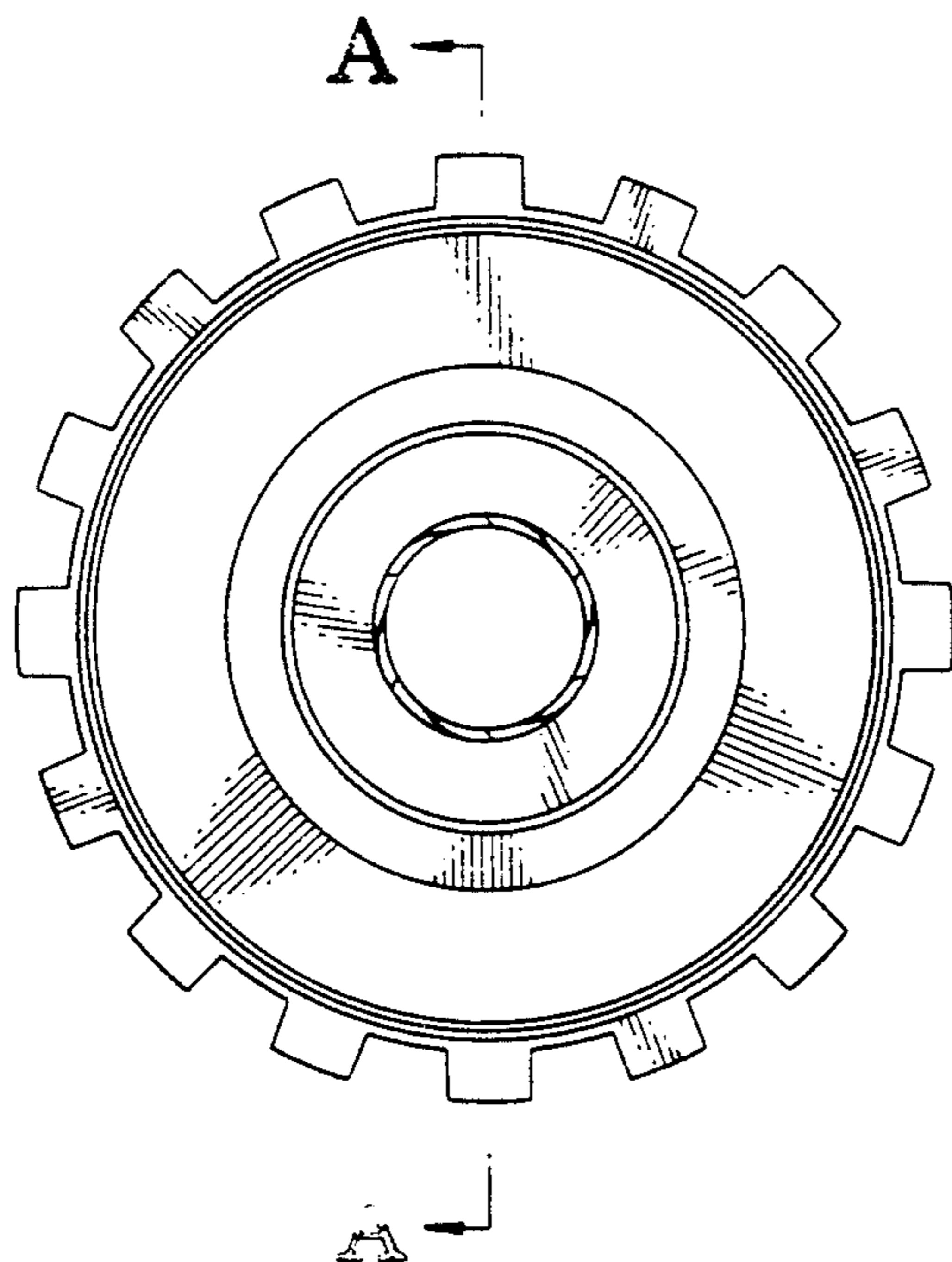

FIG.1

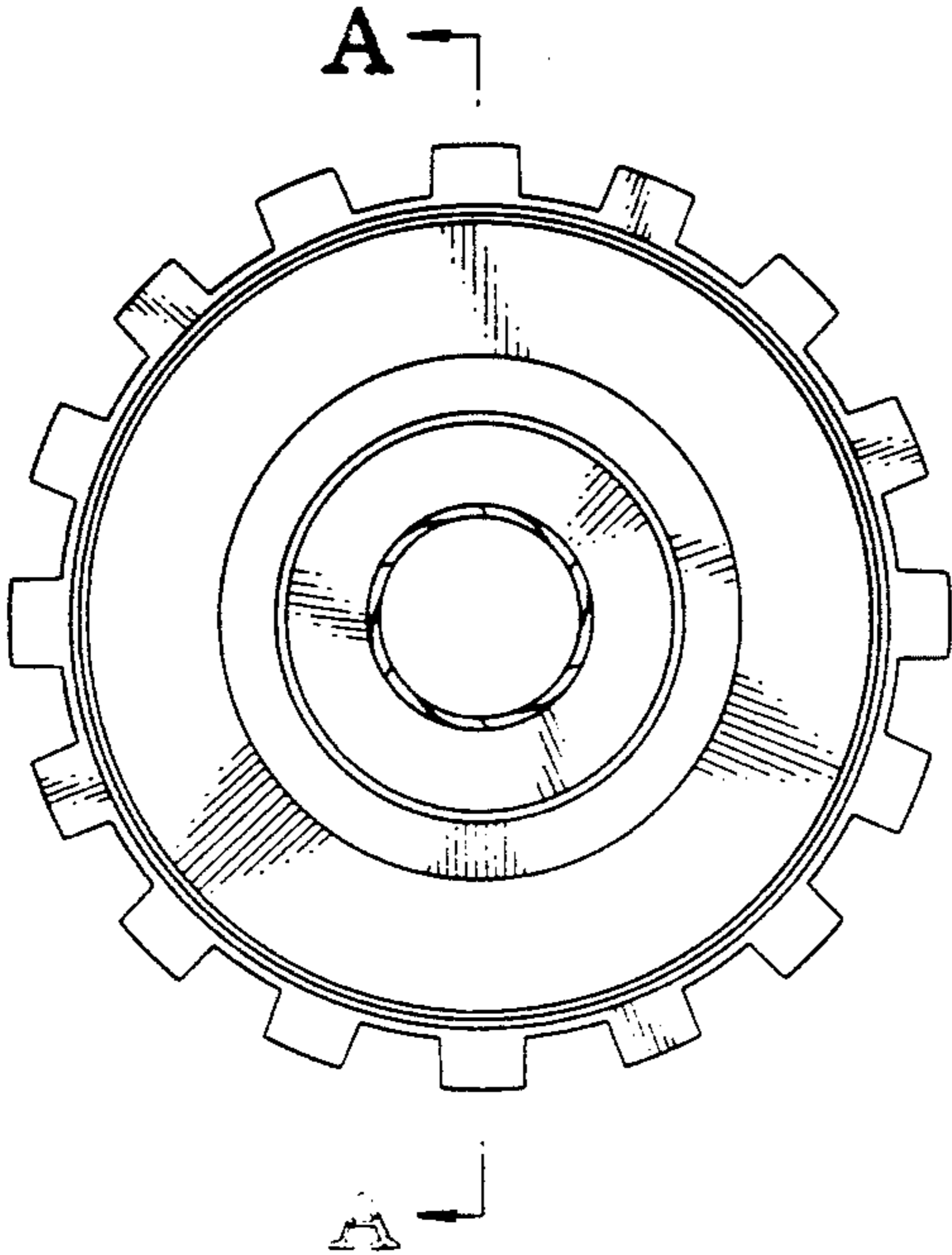

FIG.2

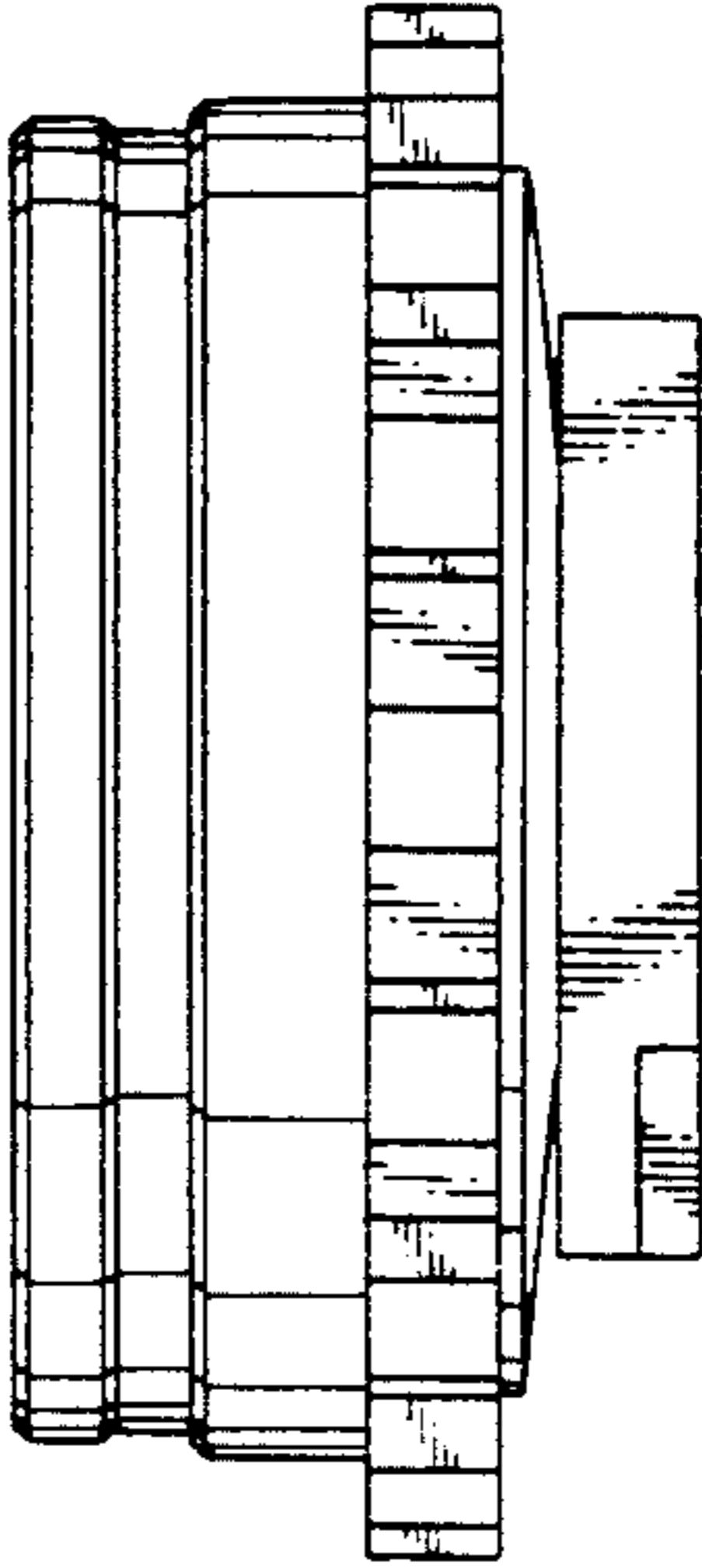

FIG.4

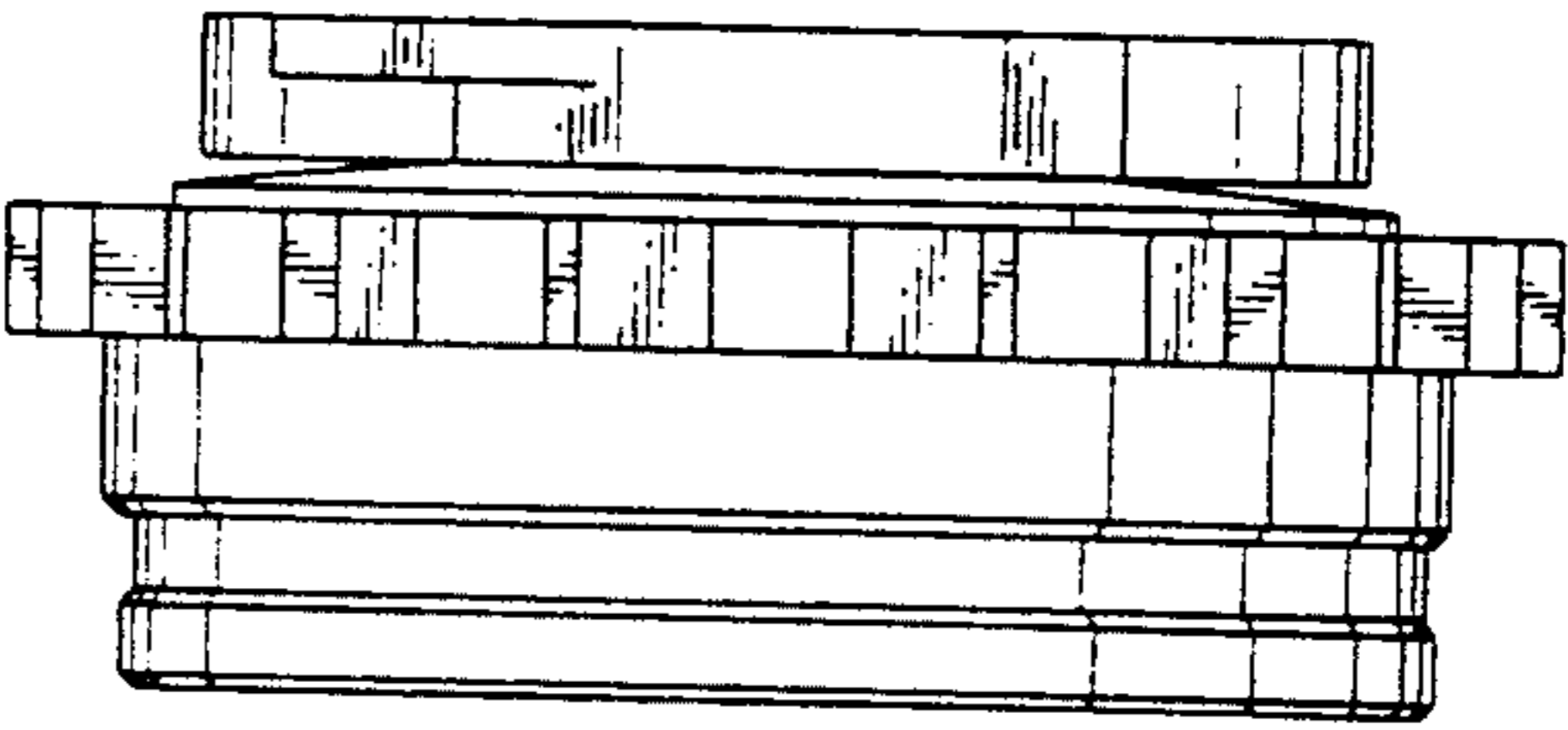

FIG.3

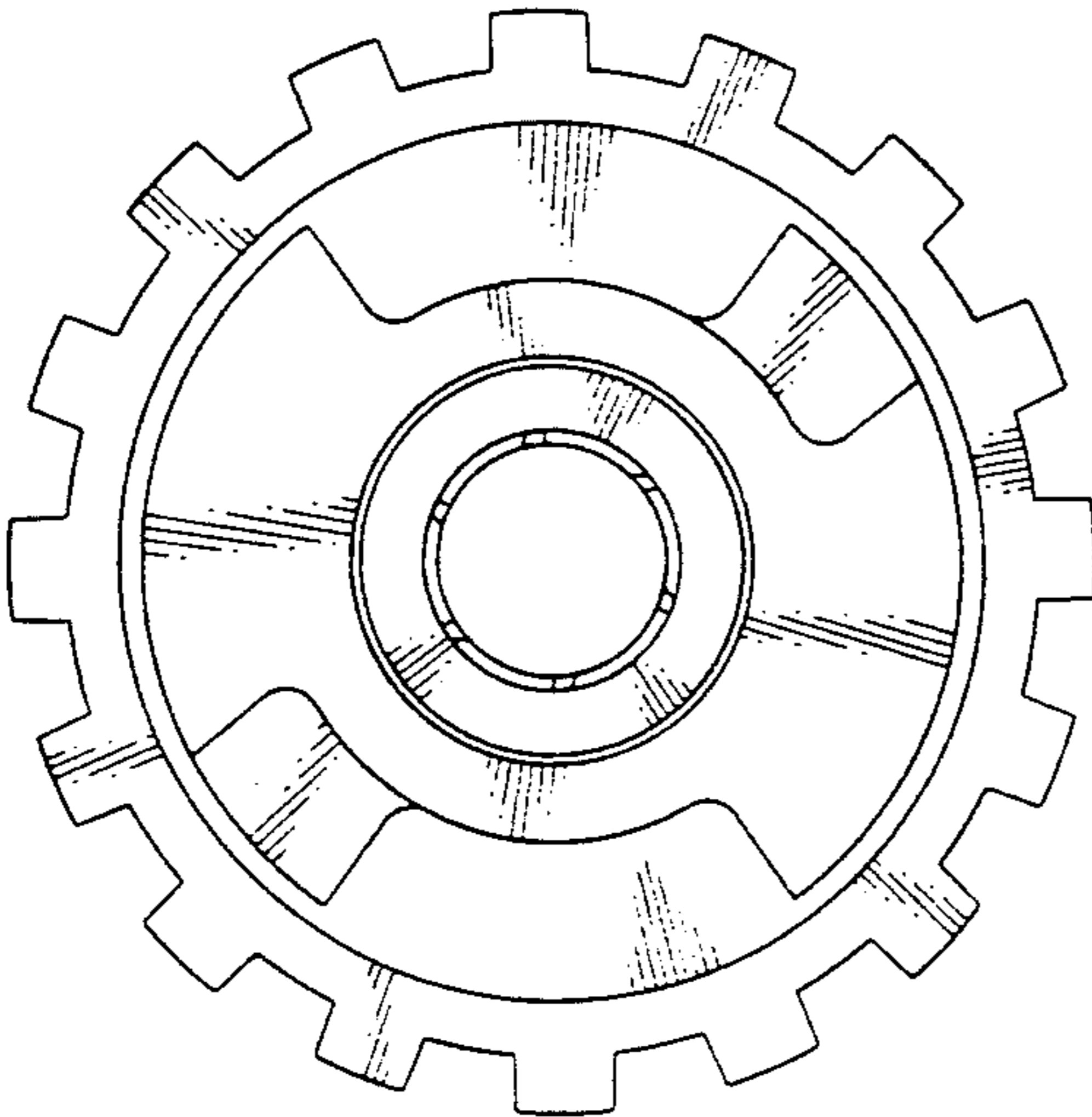

FIG.5

